

---

# Walkstations



## Understanding

Series 7 Walkstation **168**



## Specifying

Series 7 Walkstation **170**

# Series 7 Walkstation

## The Series 7

**Walkstation** consists of a fully integrated electric height adjustable worksurface with an exclusively engineered, low speed, commercial grade treadmill. ▶ Specifying, page 170

**Worksurface indent** allows user to be closer to flat panel while maintaining body alignment to the treadmill base.

**Quiet, high torque motor** is included.

**Commercial grade treadmill** has maximum speed of 2 mph in .1 mph increments and no incline adjustability.

**The Sit-to-Walkstation** provides an area where the worksurface can be lowered for seated use. The user then has the flexibility to adjust from a seated, to a standing, to a walking position with room for a chair next to the treadmill.

**Base** is painted steel.

**2 1/2" diameter glides** have 1" of height adjustment for surface leveling on uneven floors.

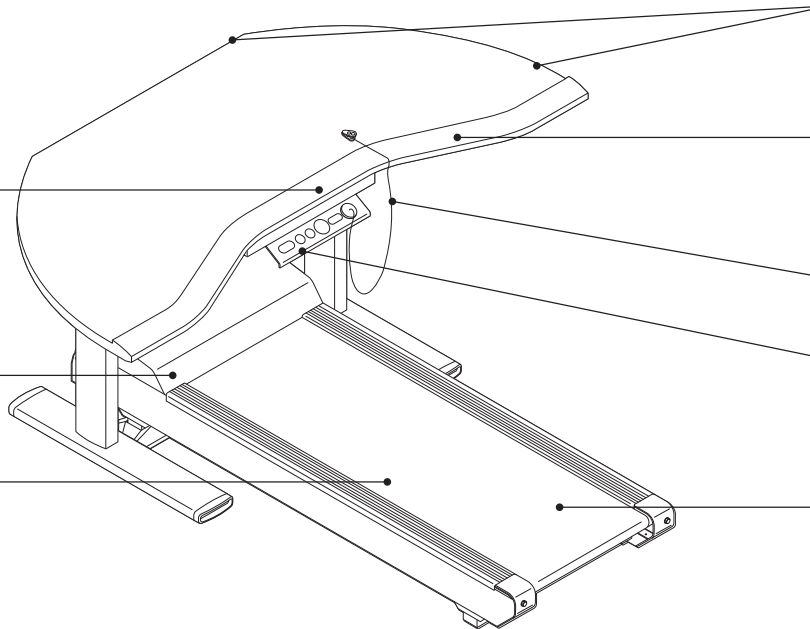

**Back and side edges** are laminate to match worksurface.

**Urethane high profile soft edge** provides grip for balance and serves as a built-in wrist rest.

**Magnetic safety clip** is standard.

**Digital key pad console** allows user to start, stop, adjust speed, and adjust worksurface height.

**Patented Soft System® surface with Neoprene shock absorber in front third of the deck** is standard.

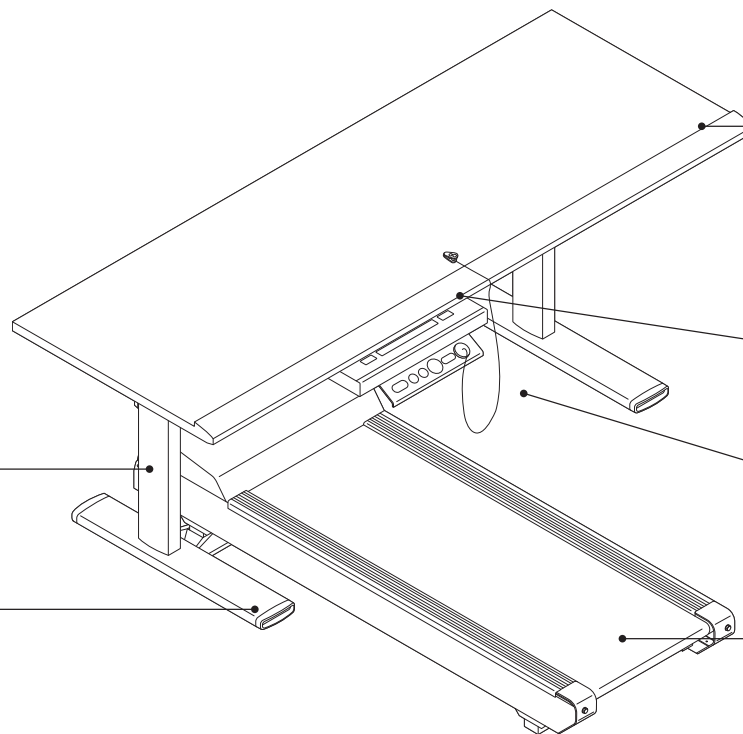

**Height-adjustable worksurface** is laminate and standard with a urethane high profile soft edge and built in wrist rest. Urethane edge is located on the front edge only.

**Digital display console** allows user to monitor speed, calories burned, time, and distance.

**Allows room for a chair** next to the treadmill.

**The treadmill** sits firmly in slots along the base of the table. In the Sit-to-Walkstation the treadmill mounts under the right- or left-side of the table.

## Actual Dimensions

	Overall Length	Overall Depth	Overall Width	Overall Height	Frame Depth	Frame Width	Frame Height
Treadmill	N.A.	67"	38", 66", or 78"	6"	64"	23 1/2"	6"
Treadmill belt	53"	N.A.	18"	N.A.	N.A.	N.A.	N.A.
Worksurface	N.A.	67"	38", 66", or 78"	N.A.	N.A.	N.A.	N.A.

**Product Details**

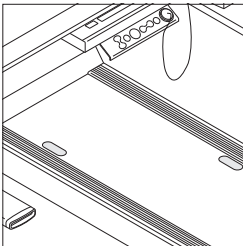

**Series 7 Walkstation** is standard with indicators on belt to show movement and belt edge.

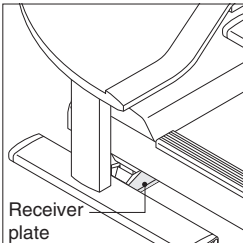

**Series 7 Walkstation** is standard with metal treadmill receiver plate between feet to insure stability and keep treadmill and worksurface aligned. *Tip: Walkstation does not incline.*

**Maximum weight capacity distributed** is 295 pounds. *Tip: When calculating lifting capacity, subtract the weight of the worksurface.*

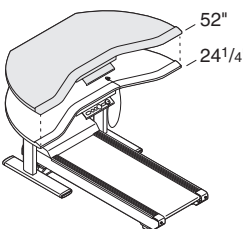

**Series 7 Walkstation** has an adjustability range of 24 1/4"H to 52"H.

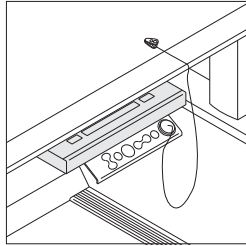

**Digital display console** allows user to monitor speed, calories, time, and distance.

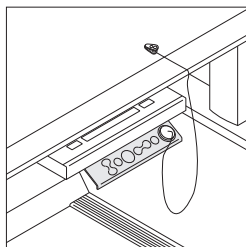

**Digital key pad console** allows user to start, stop, adjust speed, and adjust worksurface height.

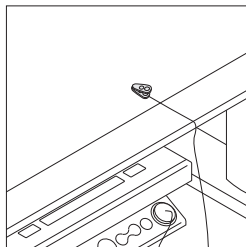

**Magnetic safety clip** should always be attached to user when walkstation is in use.

**Belt** must be in the off position before user steps on to treadmill.

**Connections**

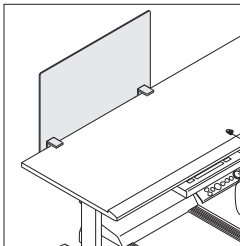

**Series 7 Walkstation** may be used with privacy/modesty screens and cableways. **▶** Pages 219 and 246

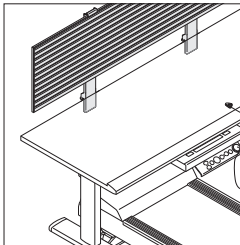

**Series 7 Walkstation** may be used with Slatwall or SlatRail to accommodate adjustable monitor arm and worktools.

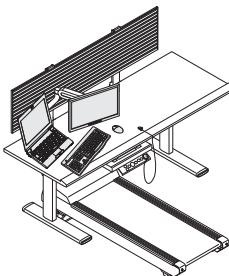

**When using a laptop computer with walkstation**, plugging in a separate keyboard, mouse, and flat panel display is recommended to provide full control over screen and keyboard positioning and to eliminate vibrations.

**Wiring and Cabling**

**Wire management trough** is provided to manage excess controller wires.

**Nine foot power cord** is standard.

**Surface Materials**

**Worksurface, back edge, and side edges**

- Laminate
- ▶ See *Surface Materials Reference Manual.*
- Open Line laminate (option)
- A program including non-Steelcase laminates which are suitable for use on Steelcase products.
- ▶ See *Surface Materials Reference Manual.*

**Urethane front edge**

- 6000 Black
- 6278 Felt

**Treadmill**

- 7270 Silverstone

**Base**

- 4799 Platinum

**Application Topics**

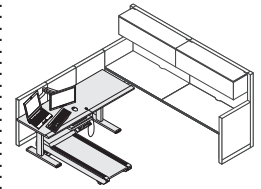

**Series 7 Walkstation** may be used in a variety of applications: meeting spaces, individual spaces, and shared spaces.

**Keyboard assemblies** are not allowed on height-adjustable desks. They do not meet minimum safety requirements.

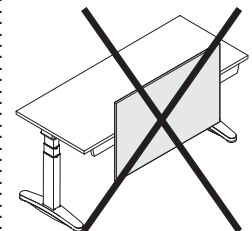

**Universal boundary screens** are not permitted on height-adjustable desks, as they do not pass minimum safety requirements which could result in the desk tipping over.

**Installation**

**Allow** three feet from the outside edge of the treadmill base on both sides and rear. The only exception is if unit is pushed up against a plain, unobstructed wall on one side.

**An FYI flat panel monitor arm** is recommended mounted to the worksurface.

**A wireless keyboard without a palm rest and wireless mouse** is recommended.

**A telephone headset** is recommended.

# Series 7 Walkstation X6/22

Standard Includes		Required to Specify
<ul style="list-style-type: none"> <li>▶ Need help? Product details, page 168</li> </ul>	<ul style="list-style-type: none"> <li>• Worksurface: High-Pressure Laminate price group 1</li> <li>• Worksurface front user's edge: urethane</li> <li>• Back and side edges: matching laminate</li> <li>• Base: 4799 Platinum</li> <li>• Treadmill: 7270 Silverstone</li> <li>• High-torque motor</li> <li>• Digital display and keypad console</li> <li>• Magnetic safety clip</li> <li>• Glides</li> </ul>	<ol style="list-style-type: none"> <li>1 Style number</li> <li>2 High-Pressure Laminate color for worksurface</li> <li>3 Urethane edge color number: 6000 Black 6278 Felt</li> <li>4 Options, if selected (see below)                     <ul style="list-style-type: none"> <li>▶ See Surface Materials, page 262.</li> </ul> </li> </ol>

**For laminate group 2 and 3 pricing, please refer to the electronic catalog or SmartTools.**

Options	U.S. Price	Required to Specify
<b>Surface Materials</b> <ul style="list-style-type: none"> <li>• High-Pressure Laminate worksurfaces</li> <li>• Laminate price group 2</li> <li>• Laminate price group 3</li> <li>• Open Line laminate</li> </ul>	See information at left See information at left +\$94 plus cost of laminate	Specify laminate color number. Specify laminate color number. ▶ See <i>Surface Materials Reference Manual</i> .

Specification Information						
Overall Footprint		Worksurface Dimensions		Weight	Style Number	U.S. Base Price
W	D	W	D			

## Series 7 Walkstation

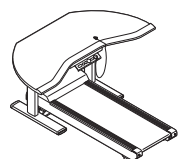

66"	67"	66"	32"	330 lb	<b>A7TG660606H</b> <span style="color: #E91E63;">X6/22</span>	\$9094
-----	-----	-----	-----	--------	---	--------

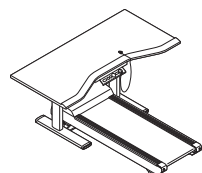

66"	67"	66"	32"	330 lb	<b>A7TR663232H</b> <span style="color: #E91E63;">X6/22</span>	\$9094
-----	-----	-----	-----	--------	---	--------

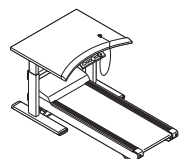

38"	67"	38"	30"	330 lb	<b>A7TR383030H</b> <span style="color: #E91E63;">X6/22</span>	\$9094
-----	-----	-----	-----	--------	---	--------

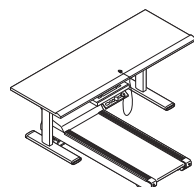

## Series 7 Sit-to-Walkstation

78"	67"	78"	29"	330 lb	<b>A7TR782929H</b> <span style="color: #E91E63;">X6/22</span>	\$9448
-----	-----	-----	-----	--------	---	--------

 **For Canadian Pricing**  
 Multiply U.S. Price by the Canadian price factor.  
 ▶ See page 1 for details.

X6/22 = Last order entry  
 June 20, 2022