Understanding and Specifying Turnstone Shortcut

Multi-Use Seating

Product Details

Shortcut Five-Star Base	324
Shortcut Five-Star Base with Personal Worksurface	326
Shortcut X Base and Shortcut Wood	328
Shortcut with Tripod Base	330
Planning with Shortcut	332
Dimensions	334

Specifying

Shortcut Five-Star Base	336
Shortcut Five-Star Base with Personal Worksurface	338
Shortcut X Base	339
Shortcut Wood	341
Shortcut with Tripod Base	342

Shortcut Five-Star Base

Shortcut is a collaborative seating collection that encourages people to move freely, change postures, and stay energized, yet comfortable in many settings.
 ▶ Specifying, pages 336–337

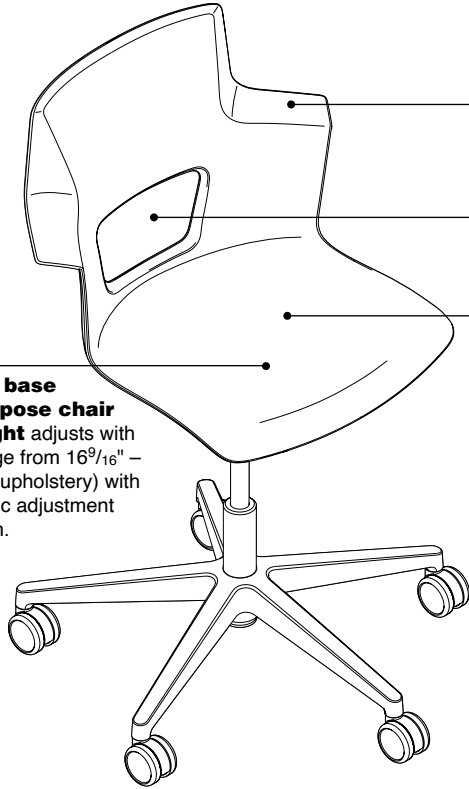

Abbreviated arms allow users to pull up to a worksurface with ease.

Cut-out provides more flexibility.

The Shortcut shell is made of polypropylene plastic.

Five-star base multi-purpose chair seat height adjusts with a $4\frac{5}{8}$ " range from $16\frac{9}{16}$ " – $21\frac{3}{16}$ " (no upholstery) with a pneumatic adjustment mechanism.

Five-star base multi-purpose stool seat height adjusts with a $10\frac{3}{16}$ " range from $22\frac{1}{8}$ " – $32\frac{5}{16}$ " (no upholstery) with a pneumatic adjustment mechanism.

Five-star base is standard.

Hard, dual wheeled casters are standard for use on carpets. Soft, roll-control, dual-wheel casters are available for use on hard floors or chair mats.

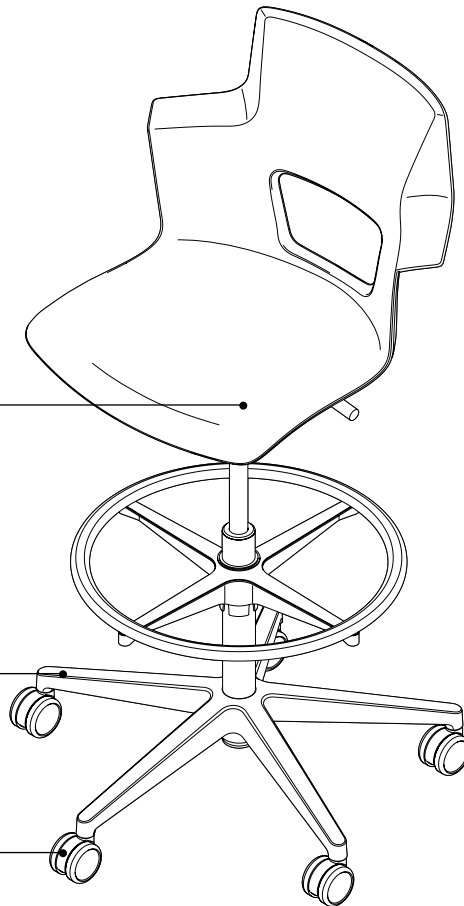

Adjustment Features

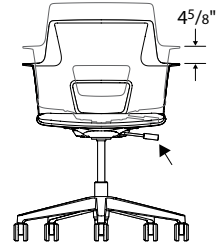

Seat height adjusts with a $4\frac{5}{8}$ " range from $16\frac{9}{16}$ " – $21\frac{3}{16}$ " (no upholstery) with a pneumatic adjustment mechanism.

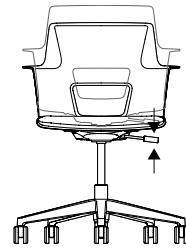

Seat height adjusts pneumatically. To lower, pull lever up while seated. To raise, pull lever up and keep weight off of the chair. Lever is located on the left hand side.

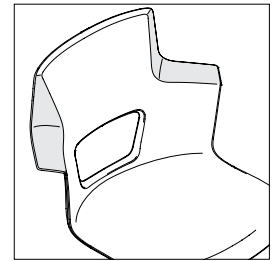

Elbow rests are abbreviated to stay out of the way as the user gets closer to the worksurface and supports a wide range of postures. It is designed to be level when in use and may appear to have slight upward angle when not in use.

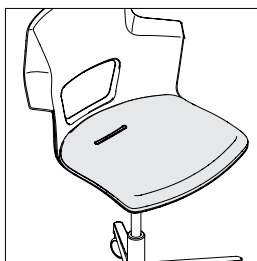

Cushion option is available for extra support and comfort.

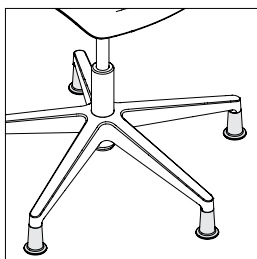

Black glides are available as an option. Glides ship assembled on the chair or stool and maintain the same height as casters.

Soft roll-control caster option features an internal brake that activates when the chair is not under load to reduce shifting when user stands up.

Soft, dual-wheel casters are two-tone, with a merle ring, which makes them easily identifiable.

Surface Materials

▶ See surface materials on page 634 for specific availability or refer to the *Surface Materials Reference Manual* for further information.

Upholstery

- Fabric
- Leather
- Elmosoft leather
- Select Surfaces leather
- COM (Customer's Own Material)
- COL (Customer's Own Leather)

Hard components

Chair (shell, five-star base)

Shell

- Plastic

Base

- 4140 Arctic White
- 4799 Platinum Metallic
- 6205 Black

Tip: Cylinder paint color defaults to coordinate with base color.

Hard casters

- 6205 Black
 - 6249 Platinum Solid
- Tip: Casters paint color defaults to coordinate with base color.*

Soft casters with 6527

- Merle ring
 - 6205 Black
 - 6249 Platinum Solid
- Tip: Casters paint color defaults to coordinate with base color.*

The Shortcut stool foot ring

is defaulted based on the paint color specified, with the exception of 4140 Arctic White, in which case the foot ring is platinum.

All Steelcase seating with standard upholstery fabrics complies with requirements of the State of California Technical Bulletin 117. All standard seating is labeled to be in compliance with California 117.

Programs & Services

Local codes may have special requirements for upholstery.

Dimensions

▶ Page 334

Shortcut Five-Star Base with Personal Worksurface

► Specifying, page 338

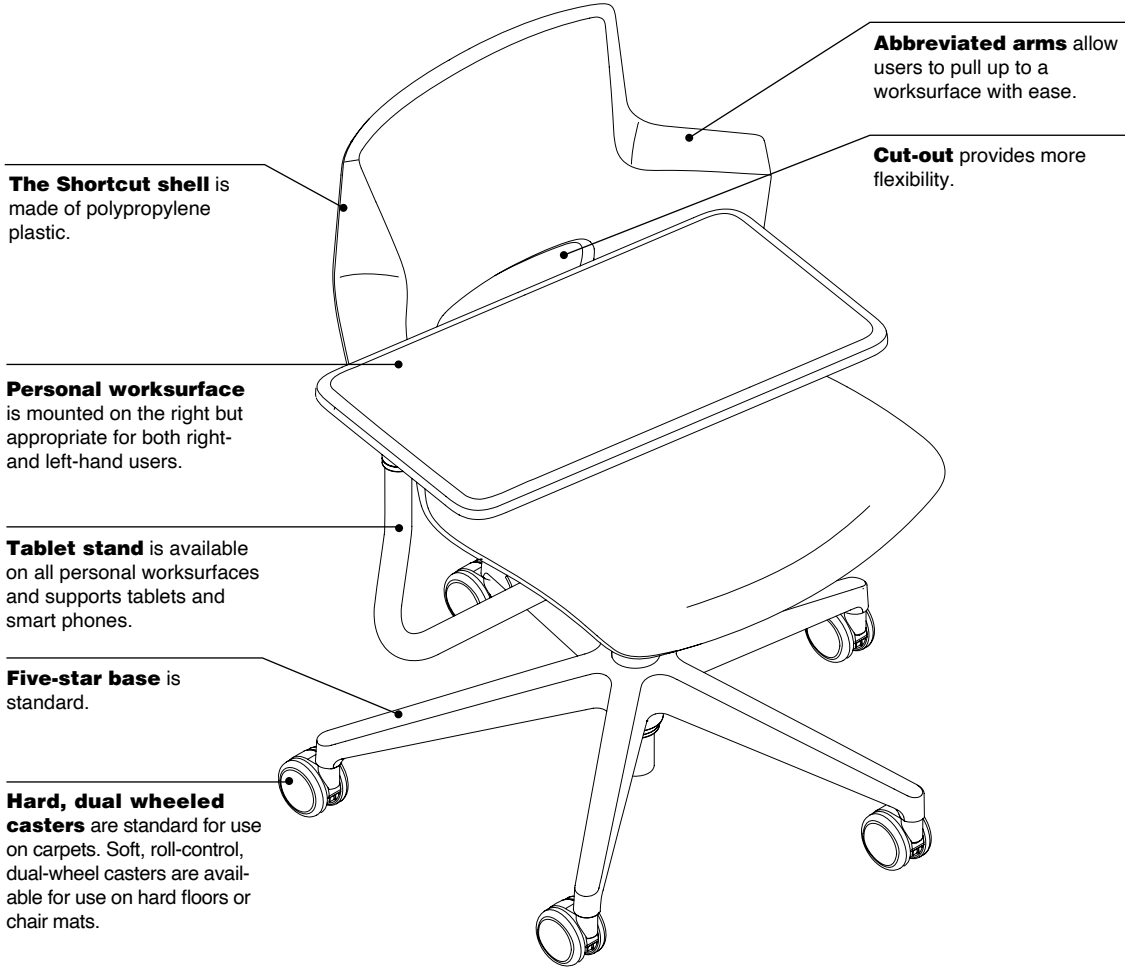

Product Details

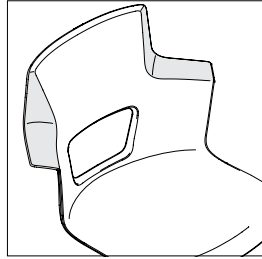

Elbow rests are abbreviated to stay out of the way as the user gets closer to the worksurface and supports a wide range of postures. It is designed to be level when in use and may appear to have slight upward angle when not in use.

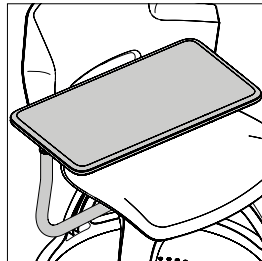

Personal worksurface is mounted on user's right, and designed to accommodate left- and right-handed users. It is 12"D x 22 1/4"W and features a safety stop to help prevent belongings and laptops from easily sliding off back edge.

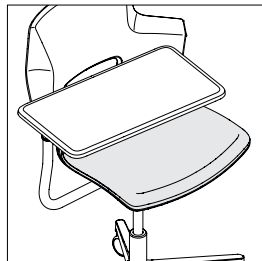

Cushion options are available for extra support and comfort.

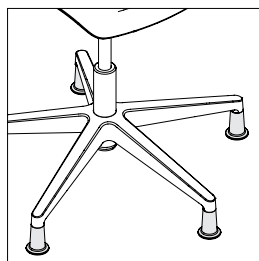

Black glides are available as an option. Glides ship assembled on the chair and maintain the same height as casters.

Soft roll-control caster option features an internal brake that activates when the chair is not under load to reduce shifting when user stands up.

Soft, dual-wheel casters are two-tone, with a merle ring, which makes them easily identifiable.

Adjustment Features

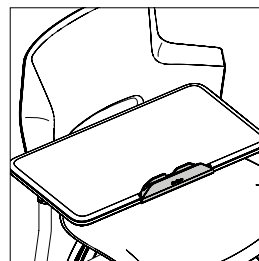

Tablet stand supports tablets and smart phones in both portrait and landscape positions, making content easy to view and freeing up space on the worksurface for other materials.

Tip: Devices are not secure in tablet stand when moved.

Cup holder is available as an option and it is retractable under the worksurface when not in use.

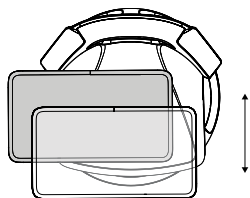

Personal worksurface depth adjustment range is 6" to 16¼". Measurement is from lumbar to worksurface.

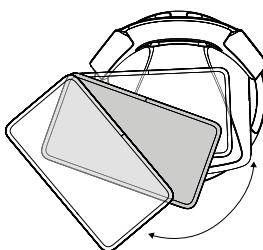

Personal worksurface pivot range is 48°.

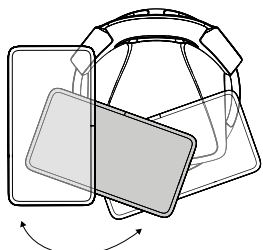

Personal worksurface center pivot is 100°. The center pivot range is measured from the closest position to the furthest position from the user.

Surface Materials

▶ See surface materials on page 634 for specific availability or refer to the *Surface Materials Reference Manual* for further information.

Upholstery

- Fabric
- Leather
- Elmosoft leather
- Select Surfaces leather
- COM (Customer's Own Material)
- COL (Customer's Own Leather)

Hard components

Chair (shell, five-star base)

Shell

- Plastic

Base

- 4140 Arctic White
 - 4799 Platinum Metallic
 - 6205 Black
- Tip: Cylinder paint color defaults to coordinate with base color.*

Hard casters

- 6205 Black
 - 6249 Platinum Solid
- Tip: Casters paint color defaults to coordinate with base color.*

Soft casters with 6527

- Merle ring
 - 6205 Black
 - 6249 Platinum Solid
- Tip: Casters paint color defaults to coordinate with base color.*

Personal worksurface

- 6053 Seagull
- 6249 Platinum Solid
- 6295 Near Black
- 6337 Element

Tablet stand and cup holder

- Sterling dark solid only

Paint for metal components

- 0835 Black
- 4140 Arctic White
- 4799 Platinum Metallic

All Steelcase seating with standard upholstery fabrics complies with requirements of the State of California Technical Bulletin 117. All standard seating is labeled to be in compliance with California 117.

Programs & Services

Local codes may have special requirements for upholstery.

Dimensions

▶ Page 334

Shortcut X Base and Shortcut Wood

► Specifying, pages 339–340

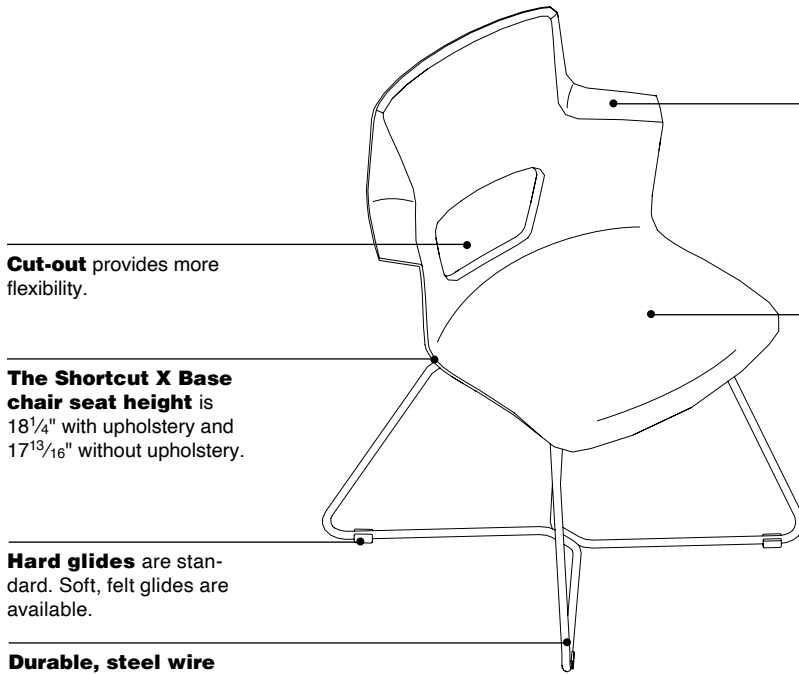

Cut-out provides more flexibility.

The Shortcut X Base chair seat height is 18¹/₄" with upholstery and 17¹³/₁₆" without upholstery.

Hard glides are standard. Soft, felt glides are available.

Durable, steel wire frame is lightweight.

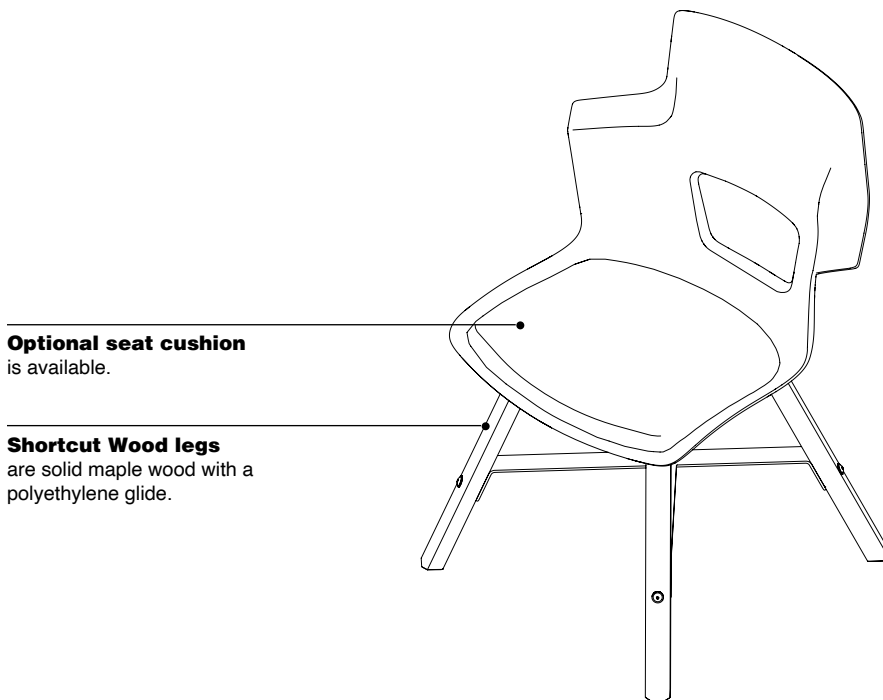

Optional seat cushion is available.

Shortcut Wood legs are solid maple wood with a polyethylene glide.

Adjustment Features

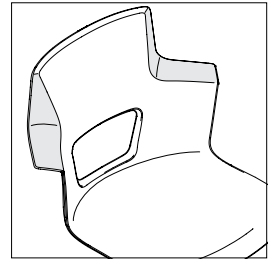

Elbow rests are abbreviated to stay out of the way as the user gets closer to the worksurface and supports a wide range of postures.

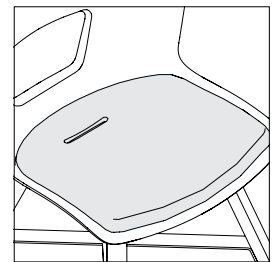

Cushion option is available for extra support and comfort.

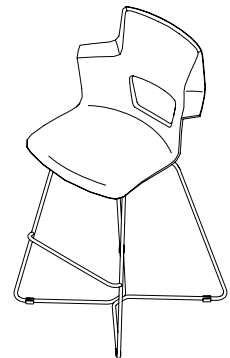

The Shortcut X Base stool seat height is 29³/₈" with upholstery and 28¹/₁₆" without upholstery.

Surface Materials

▶ See surface materials on page 634 for specific availability or refer to the *Surface Materials Reference Manual* for further information.

Shortcut X Base

Upholstery

- Fabric
- Leather
- Elmosoft leather
- Select Surfaces leather
- COM (Customer's Own Material)
- COL (Customer's Own Leather)

Shell

- Plastic

Base

- Paint

▶ For Surface Materials matrices for all product lines, see page 648

Shortcut Wood

Upholstery

- Fabric
- Leather
- Elmosoft leather
- Select Surfaces leather
- COM (Customer's Own Material)
- COL (Customer's Own Leather)

Shell

- Plastic

Legs

- V1AC Natural Cherry
- V1AM Clear Maple
- V1CC Medium Amber Cherry
- V1EW Dark Walnut

Brackets

- Paint
- Accent Paint
- PerfectMatch Paint

All Steelcase seating with standard upholstery fabrics complies with requirements of the State of California Technical Bulletin 117. All standard seating is labeled to be in compliance with California 117.

Programs & Services

Local codes may have special requirements for upholstery.

Dimensions

▶ Page 334

Shortcut with Tripod Base

► Specifying, page 342

Abbreviated arms allow users to pull up to a worksurface with ease.

Cut-out provides more flexibility.

360°-swivel mechanism is standard.

Backpack storage area is standard.

Casters have hard dual wheels that roll smoothly on carpets. Soft dual-wheel casters are available for use on hard floors.

Tablet stand is available on all personal worksurfaces and supports tablets and smart phones.

Personal worksurface moves independently of seat shell and base.

Personal worksurface is mounted on the right but appropriate for both right- and left-hand users.

Personal worksurface is depth adjustable for large and small users and allows for ingress/egress.

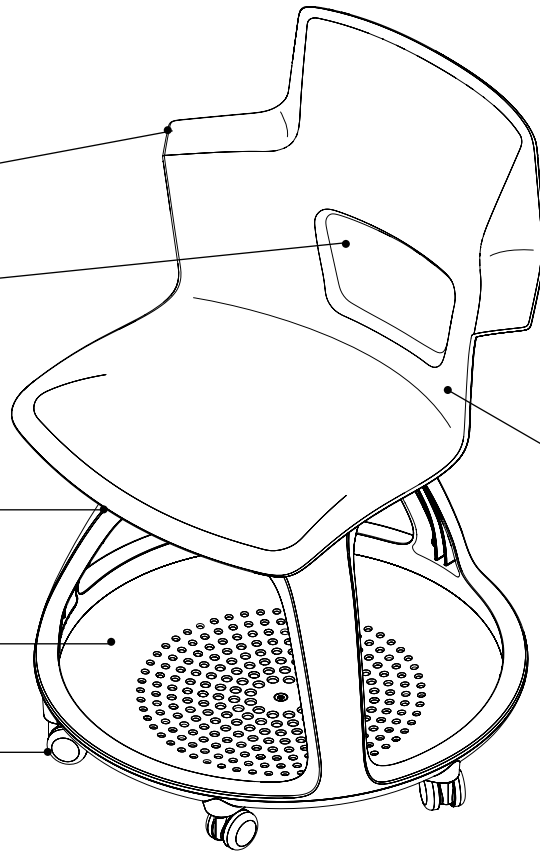

The Shortcut shell is made of polypropylene plastic.

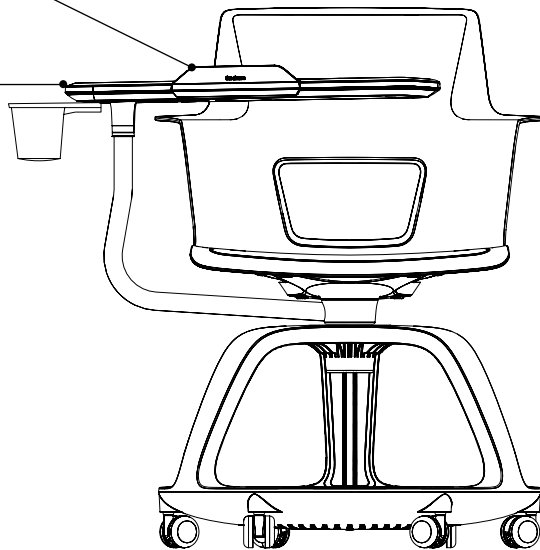

Product Details

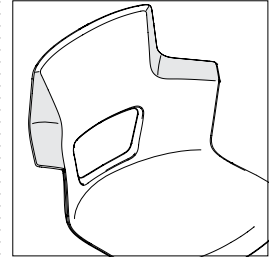

Elbow rests are abbreviated to stay out of the way as the user gets closer to the worksurface and supports a wide range of postures.

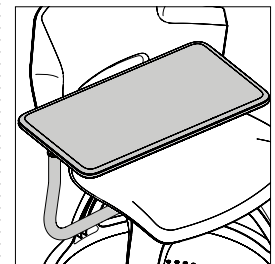

Personal worksurface is mounted on user's right, and designed to accommodate left- and right-handed users. It is 12"D x 22 1/4"W and features a safety stop to help prevent belongings and laptops from easily sliding off back edge.

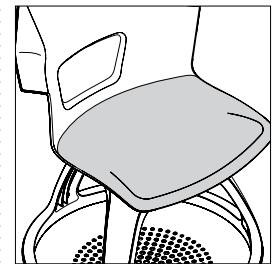

Cushion options are available for extra support and comfort.

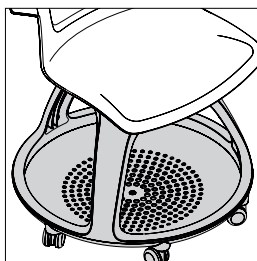

Tripod base reclaims the space under the seat. The space is 1.7 cu/ft and allows for backpack or personal belongings to be stored.

Adjustment Features

360° fixed height swivel mechanism on tripod base models allows students to remain oriented to instructor, presentation materials, and other students.

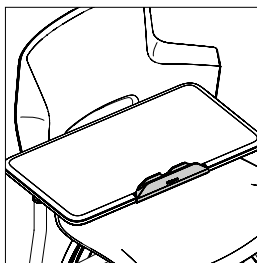

Tablet stand is available on chairs with personal worksurfaces. The stand supports tablets and smart phones in both portrait and landscape positions, making content easy to view and freeing up space on the worksurface for other materials.

Tip: Devices are not secure in tablet stand when moved.

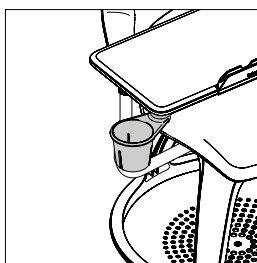

Cup holder is available as an option on Shortcut chairs with personal worksurfaces. It is retractable under the worksurface when not in use.

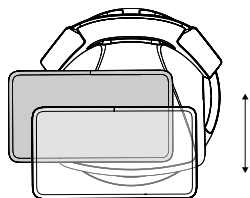

Personal worksurface depth adjustment range is 6" to 16¼". Measurement is from lumbar to worksurface.

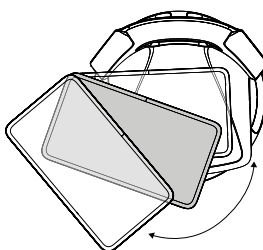

Personal worksurface pivot range is 48°.

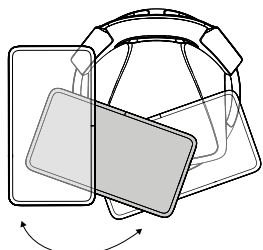

Personal worksurface center pivot is 100°. The center pivot range is measured from the closest position to the furthest position from the user.

Surface Materials

▶ See surface materials on page 634 for specific availability or refer to the *Surface Materials Reference Manual* for further information.

Shell

- Plastic

Upholstery

- Fabric
- Leather
- Elmosoft leather
- Select Surfaces leather
- COM (Customer's Own Material)
- COL (Customer's Own Leather)

Tripod base

- 6249 Platinum Solid
- 6295 Near Black
- 6337 Element

Storage tray/bottom of tripod base

- Sterling dark solid only

Personal worksurface

- 6053 Seagull
- 6249 Platinum Solid
- 6295 Near Black
- 6337 Element

Casters

- Black

Glides

- Sterling dark solid only

Tablet stand and cup holder

- Sterling dark solid only

Paint for metal components

- 0835 Black
- 4140 Arctic White
- 4799 Platinum Metallic

Dimensions

▶ Page 334

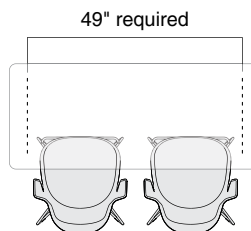

The backpack storage area and overall chair width require 23¾" of continuous floor space when used with tables. The minimum distance between table bases is 49" to allow two chairs to be pushed under the worksurface.

Planning with Shortcut

For Classroom Environments

Pedagogy, technology and space, when carefully considered and intentionally designed, can establish new protocols for advanced learning solutions.

Planning Tips

- 1 Illustrate multiple modes for each drawing to:
 - a) ensure enough space is available for each reconfiguration
 - b) allow the user to understand what's possible
 - c) ensure that sight lines are maintained when the furniture is moved
 - d) confirm that jurisdictional codes are followed for each layout (eg: International Building Code, American Disability Act, etc.)
- 2 Give permission to act differently by including wall guard and enough space to move, supporting simultaneous multi-modal activities.
- 3 Provide both analogue and digital tools in the solution such as whiteboards, personal whiteboards, interactive whiteboards or media:scape.
- 4 Address the needs of classroom and personal storage for both students and teachers. Incorporate this information into each mode to ensure space is adequate.
- 5 Include zones for mentoring, assessment, and/or coaching for teacher-to-student and/or student-to-student interaction.
- 6 Annotate the drawings with design principles to confirm they are being addressed.

Lecture Mode

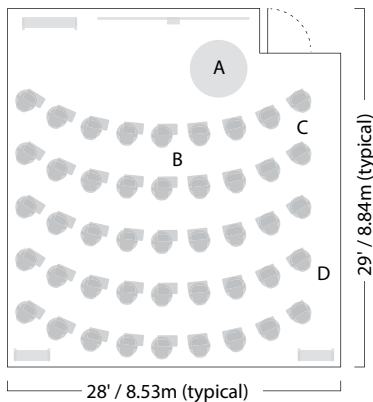

Group Mode

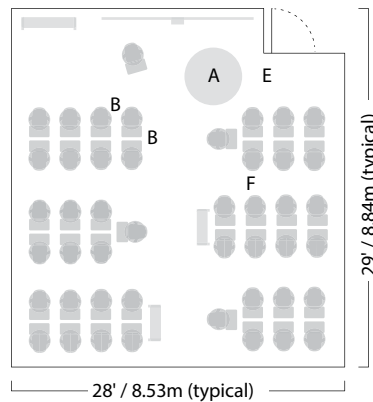

Discussion Mode

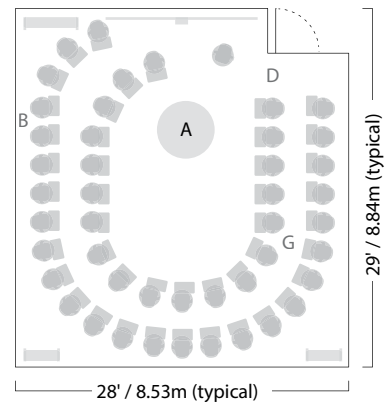

This example: 18* sq. ft. or 1.68 sq. meters per person. *For K-12 applications,
 ▶ See Table 1004.1.1 Maximum Floor Area Allowances per Occupant, 2009 International Building Code.

- A** — 60"/1.52m (ADA)
- B** — 12"/0.3m
- C** — 18"-24"/0.46-0.61m (aisle)
- D** — 36"/0.91m (egress)
- E** — 60"/1.52m (egress)
- F** — 38"/0.97m (aisle)
- G** — 18"-36"/0.46-0.91m (aisle)

Dimensions

Shortcut

Features	Overall Depth	Width	Height	Seat Depth	Seat Width	Seat Height from Floor
----------	---------------	-------	--------	------------	------------	------------------------

Shortcut

Multi-Use Seating

Five-Star Base Chair	24½"	24⅛"	31½"-35⅝"	16⅞"	19⅝"	16⅞"-21⅜"
Five-Star Base Stool	24½"	24⅛"	36⅝"-47"	16⅞"	19⅝"	22⅛"-32⅝"
Five-Star Base with Personal Worksurface	24½"	34½"	31¾"-37¾"	16⅞"	19⅝"	16⅞"-21⅜"
X Base Chair	21½"	24⅛"	33"	16⅞"	19⅝"	17⅜"
X Base Stool	21½"	24⅛"	44"	16⅞"	19⅝"	28⅛"
Wood Chair	27¾"	24⅛"	33"	16⅞"	19⅝"	17⅜"
Chair with Tripod Base	23¾"	25⅝"	33½"	16⅞"	19⅝"	18⅜" (19⅛")
Chair with Tripod Base and Personal Worksurface	31"	34½"	33½"	16⅞"	19⅝"	18⅜" (19⅛")

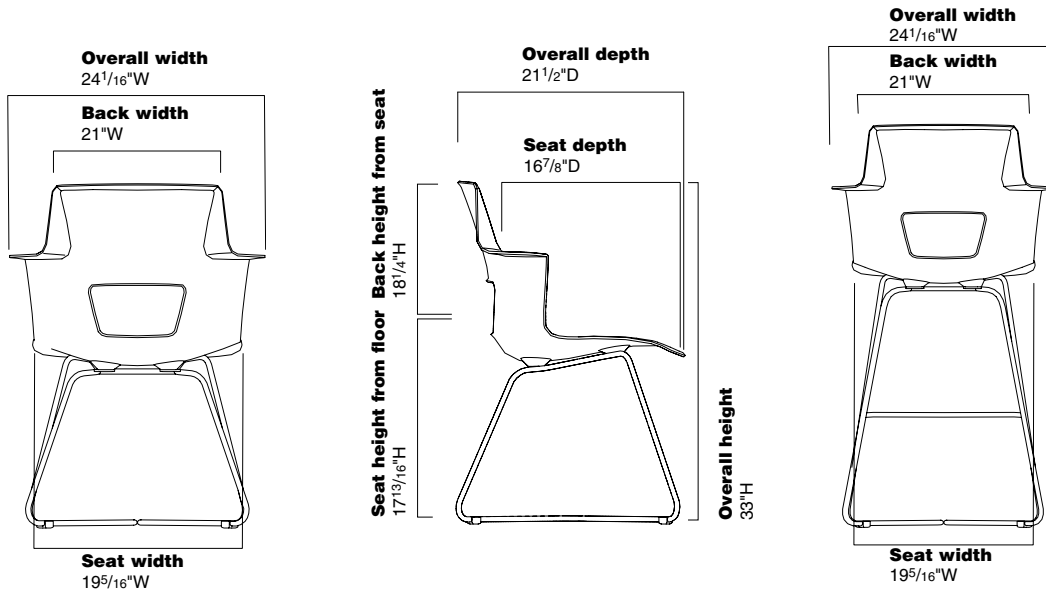
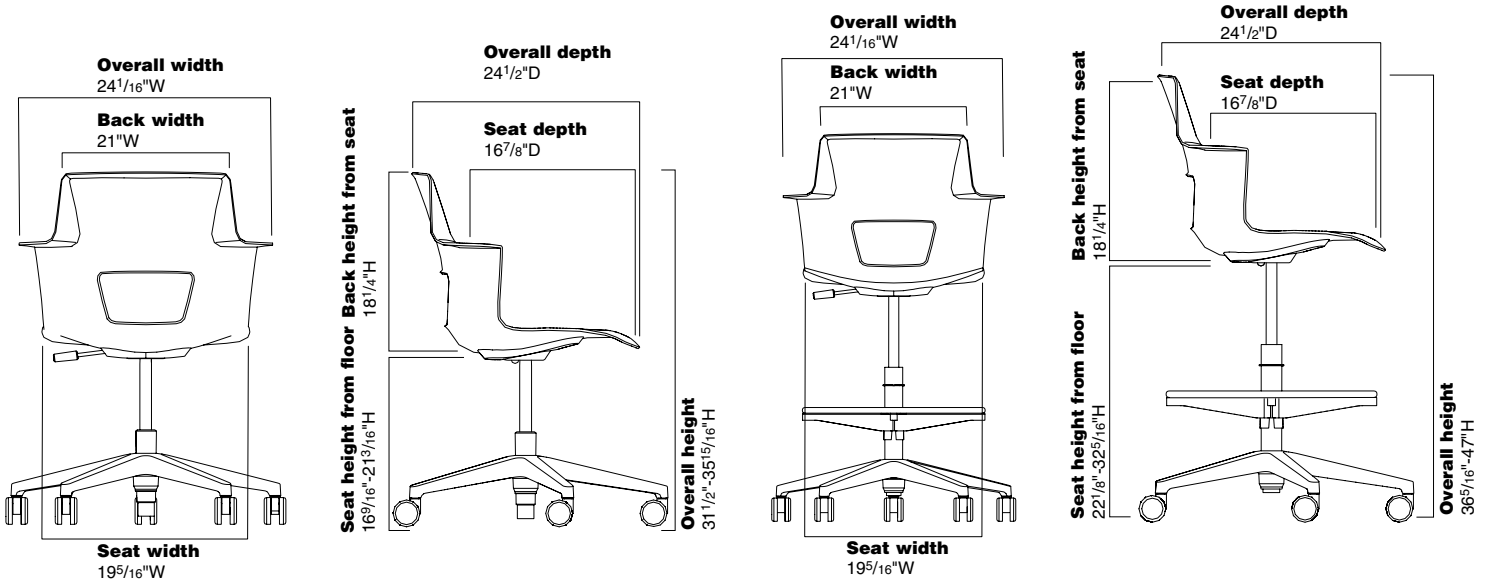

• Back Width	• Back Height from Seat	• Back Lumbar Height	• Seat Pan Angle	• Angle Between Seat and Back	• Width Between Elbow Rest	• Elbow Rest to Floor
21"	18 ¹ / ₄ "	9 ¹ / ₄ "	8.3°	within 0-4°	21"	N.A.
21"	18 ¹ / ₄ "	9 ¹ / ₄ "	8.3°	within 0-4°	21"	N.A.
21"	18 ¹ / ₄ "	9 ¹ / ₄ "	8.3°	within 0-4°	21"	N.A.
21"	18 ¹ / ₄ "	9 ¹ / ₄ "	8°	within 0-4°	21"	26 ¹ / ₄ "
21"	18 ¹ / ₄ "	9 ¹ / ₄ "	8°	within 0-4°	21"	37 ¹ / ₄ "
21"	18 ¹ / ₄ "	9 ¹ / ₄ "	5 - 8°	within 0-4°	21"	26 ¹ / ₄ "
21"	18 ¹ / ₄ "	9 ¹ / ₄ "	8.3°	within 0-4°	21"	26 ³ / ₄ "
21"	18 ¹ / ₄ "	9 ¹ / ₄ "	8.3°	within 0-4°	21"	26 ³ / ₄ "

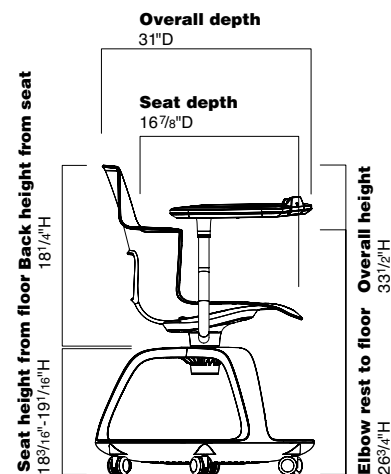
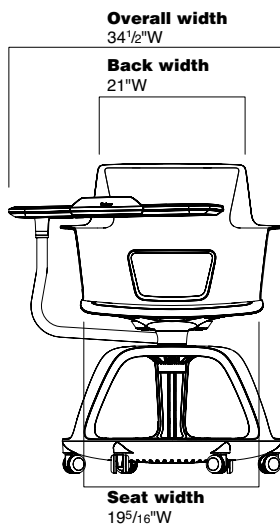
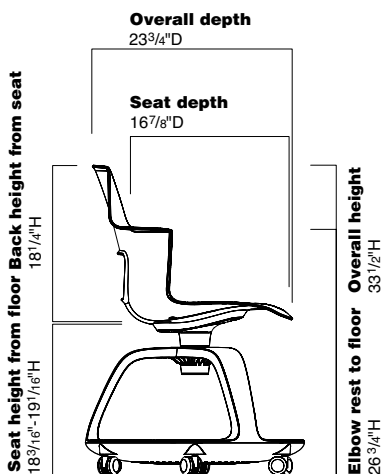
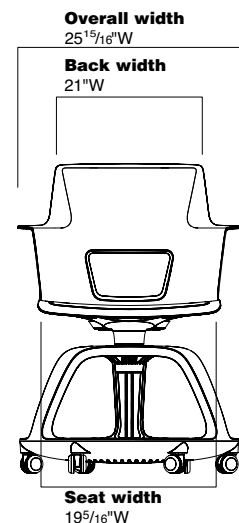
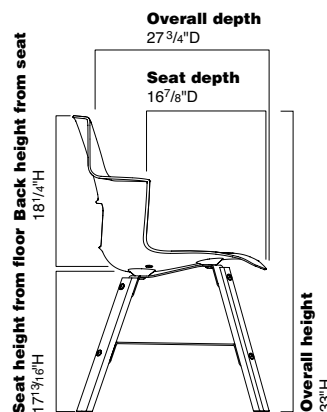
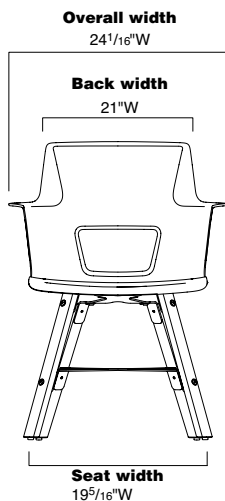
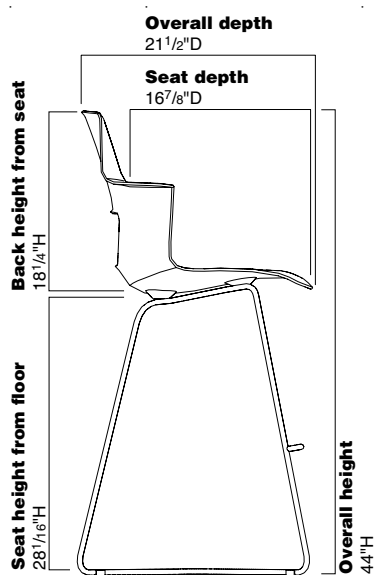

Shortcut

Shortcut

Five-Star Base Chair



Tip: Hard dual-wheel casters are for use on carpet. Use on hard surfaces, including floor mats, will affect chair stability and may result in personal injury.

Tip: Upholstery is only applicable if seat cushion is a selected option.

Tip: Craft in upholstery cautions the use of stripes and patterns on Shortcut. Please use fabric database when specifying.

Tip: Casters default to coordinate with base color.

Standard Includes		Required to Specify
<ul style="list-style-type: none"> ▶ Need help? Product details, page 324 	<ul style="list-style-type: none"> • Seat shell: plastic • Five-star base: 6205 Black plastic • Pneumatic seat height • Hard dual-wheel casters: 6205 Black • Shipped ready to assemble • Meets Cal. 117 requirements 	<ul style="list-style-type: none"> 1 Style number 2 Color number for base 3 Plastic color number for shell 4 Options, if selected (see below) ▶ See <i>Surface Materials</i>, page 634.

Options		U.S. Price	Required to Specify
Seat Cushion	• Cushion	+\$215	Specify <i>with cushion</i> and specify fabric color number.
Surface Materials	Upholstery <ul style="list-style-type: none"> • Fabric price group 1 • Fabric price group 2 • Fabric price group 3 • Fabric price group 4 • Fabric price group 5 • Fabric price group 6 • Fabric price group 7 • Fabric price group 8 • Fabric price group 9 • Fabric price group 10 • Steelcase leather • Select Surfaces leather price group 1 • Elmosoft leather • Select Surfaces leather price group 2 • Vinyl • Customer's Own Material (COM) 	<ul style="list-style-type: none"> No cost +\$ 16 +\$ 37 +\$ 53 +\$ 62 +\$ 77 +\$ 94 +\$113 +\$140 +\$162 +\$136 +\$136 +\$160 +\$160 +\$ 16 +\$ 56 	<ul style="list-style-type: none"> Specify fabric color number. Specify fabric color number. Specify fabric color number. Specify fabric color number. Specify fabric color number. Specify fabric color number. Specify fabric color number. Specify fabric color number. Specify fabric color number. Specify fabric color number. Specify leather color number. ▶ See <i>Surface Materials Reference Manual</i>. Specify Elmosoft color number. ▶ See <i>Surface Materials Reference Manual</i>. Specify vinyl color number. ▶ See <i>Understanding Customer's Own Material (COM)</i>, page 642. ▶ See <i>Understanding Customer's Own Material (COM)</i>, page 642.
	Base <ul style="list-style-type: none"> • Arctic white gloss • Platinum metallic 	<ul style="list-style-type: none"> +\$ 56 +\$ 56 	<ul style="list-style-type: none"> Specify <i>with 4140 Arctic White Gloss</i>. Specify <i>with 4799 Platinum Metallic</i>.
	Shell <ul style="list-style-type: none"> • Plastic price group 1 • Plastic price group 2 	<ul style="list-style-type: none"> No cost +\$ 53 	<ul style="list-style-type: none"> Specify plastic color number. Specify plastic color number.
Casters	<ul style="list-style-type: none"> • Hard casters • Soft dual-wheel casters for use on hard floors 	<ul style="list-style-type: none"> No cost +\$ 47 	<ul style="list-style-type: none"> Specify <i>with hard casters</i>. Specify <i>with soft casters</i>.
Glides	• Non-marring plastic glides	+\$ 47	Specify <i>with glides</i> .

Specification Information	
• Style Number	• U.S. Base Price
TS31201A	\$647

▶ Detailed dimensions, page 334

For Canadian Pricing
 Multiply U.S. Price by the Canadian price factor.
 ▶ See page 1 for details.

Shortcut

Five-Star Base Stool

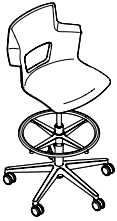

Tip: Hard dual-wheel casters are for use on carpet. Use on hard surfaces, including floor mats, will affect chair stability and may result in personal injury.

Tip: Upholstery is only applicable if seat cushion is a selected option.

Tip: Craft in upholstery cautions the use of stripes and patterns on Shortcut. Please use fabric database when specifying.

Tip: Casters default to coordinate with base color.

Standard Includes	Required to Specify
-------------------	---------------------

<ul style="list-style-type: none"> ▶ Need help? Product details, page 324 	<ul style="list-style-type: none"> • Seat shell: plastic • Five-star base: 6205 Black plastic • Pneumatic seat height • Hard dual-wheel casters: 6205 Black • Shipped ready to assemble • Meets Cal. 117 requirements 	<ol style="list-style-type: none"> 1 Style number 2 Color number for base 3 Plastic color number for shell 4 Options, if selected (see below) <ul style="list-style-type: none"> ▶ See <i>Surface Materials</i>, page 634.
--	---	---

Options	U.S. Price	Required to Specify
---------	------------	---------------------

Seat Cushion	• Cushion	+\$215	Specify <i>with cushion</i> and specify fabric color number.
---------------------	-----------	--------	--

Surface Materials	Upholstery	U.S. Price	Required to Specify
-------------------	------------	------------	---------------------

• Fabric price group 1	• Fabric price group 1	No cost	Specify fabric color number.
• Fabric price group 2	• Fabric price group 2	+\$ 16	Specify fabric color number.
• Fabric price group 3	• Fabric price group 3	+\$ 37	Specify fabric color number.
• Fabric price group 4	• Fabric price group 4	+\$ 53	Specify fabric color number.
• Fabric price group 5	• Fabric price group 5	+\$ 62	Specify fabric color number.
• Fabric price group 6	• Fabric price group 6	+\$ 77	Specify fabric color number.
• Fabric price group 7	• Fabric price group 7	+\$ 94	Specify fabric color number.
• Fabric price group 8	• Fabric price group 8	+\$113	Specify fabric color number.
• Fabric price group 9	• Fabric price group 9	+\$140	Specify fabric color number.
• Fabric price group 10	• Fabric price group 10	+\$162	Specify fabric color number.
• Steelcase leather	• Steelcase leather	+\$136	Specify fabric color number.
• Select Surfaces leather price group 1	• Select Surfaces leather price group 1	+\$136	Specify leather color number.
• Elmosoft leather	• Elmosoft leather	+\$160	▶ See <i>Surface Materials Reference Manual</i> . Specify Elmosoft color number.
• Select Surfaces leather price group 2	• Select Surfaces leather price group 2	+\$160	▶ See <i>Surface Materials Reference Manual</i> .
• Vinyl	• Vinyl	+\$ 16	Specify vinyl color number.
• Customer's Own Material (COM)	• Customer's Own Material (COM)	+\$ 56	▶ See <i>Understanding Customer's Own Material (COM)</i> , page 642.
• Customer's Own Leather (COL)	• Customer's Own Leather (COL)	+\$ 56	▶ See <i>Understanding Customer's Own Material (COM)</i> , page 642.

Base	U.S. Price	Required to Specify
------	------------	---------------------

• Arctic white gloss	+\$ 56	Specify <i>with 4140 Arctic White Gloss</i> .
• Platinum metallic	+\$ 56	Specify <i>with 4799 Platinum Metallic</i> .

Shell	U.S. Price	Required to Specify
-------	------------	---------------------

• Plastic price group 1	No cost	Specify plastic color number.
• Plastic price group 2	+\$ 53	Specify plastic color number.

Casters	U.S. Price	Required to Specify
---------	------------	---------------------

• Hard casters	No cost	Specify <i>with hard casters</i> .
• Soft dual-wheel casters for use on hard floors	+\$ 47	Specify <i>with soft casters</i> .

Glides	U.S. Price	Required to Specify
--------	------------	---------------------

• Non-marring plastic glides	+\$ 47	Specify <i>with glides</i> .
------------------------------	--------	------------------------------

Specification Information	
---------------------------	--

Style Number	U.S. Base Price
--------------	-----------------

TS31 202B	\$916
-----------	-------

▶ Detailed dimensions, page 334

For Canadian Pricing
 Multiply U.S. Price by the Canadian price factor.
 ▶ See page 1 for details.

Shortcut

Five-Star Base Chair with Personal Worksurface



Tip: Hard dual-wheel casters are for use on carpet. Use on hard surfaces, including floor mats, will affect chair stability and may result in personal injury.

Tip: Upholstery is only applicable if seat cushion is a selected option.

Tip: Craft in upholstery cautions the use of stripes and patterns on Shortcut. Please use fabric database when specifying.

Tip: Metal components include shell bracket and personal worksurface arm that default to match the base finish.

Tip: Casters default to coordinate with base color.

► Detailed dimensions, page 334



For Canadian Pricing
Multiply U.S. Price by the Canadian price factor.
► See page 1 for details.

Standard Includes		Required to Specify
► Need help? Product details, page 326	<ul style="list-style-type: none"> • Seat shell: plastic • Five-star base: 6205 Black plastic • Pneumatic seat height • Hard dual-wheel casters: 6205 Black • Metal components: paint • Swivel seat • Personal Worksurface: plastic • Shipped ready to assemble • Meets Cal. 117 requirements 	<ol style="list-style-type: none"> 1 Style number 2 Color number for base 3 Plastic color number for shell 4 Paint for metal components 5 Plastic color number for Personal Worksurface 6 Options, if selected (see below) <p>► See <i>Surface Materials</i>, page 634.</p>

	Options	U.S. Price	Required to Specify
Seat Cushion	• Cushion	+\$215	Specify <i>with cushion</i> and specify fabric color number.
Surface Materials	<p>Upholstery</p> <ul style="list-style-type: none"> • Fabric price group 1 No cost • Fabric price group 2 +\$ 16 • Fabric price group 3 +\$ 37 • Fabric price group 4 +\$ 53 • Fabric price group 5 +\$ 62 • Fabric price group 6 +\$ 77 • Fabric price group 7 +\$ 94 • Fabric price group 8 +\$113 • Fabric price group 9 +\$140 • Fabric price group 10 +\$162 • Steelcase leather +\$136 • Select Surfaces leather price group 1 +\$136 • Elmosoft leather +\$160 • Select Surfaces leather price group 2 +\$160 • Vinyl +\$ 16 • Customer's Own Material (COM) +\$ 56 <p>Base</p> <ul style="list-style-type: none"> • Arctic white gloss +\$ 56 • Platinum metallic +\$ 56 <p>Shell</p> <ul style="list-style-type: none"> • Plastic price group 1 No cost • Plastic price group 2 +\$ 53 		<p>Specify fabric color number.</p> <p>Specify fabric color number.</p> <p>Specify fabric color number.</p> <p>Specify fabric color number.</p> <p>Specify fabric color number.</p> <p>Specify fabric color number.</p> <p>Specify fabric color number.</p> <p>Specify fabric color number.</p> <p>Specify fabric color number.</p> <p>Specify fabric color number.</p> <p>Specify leather color number.</p> <p>► See <i>Surface Materials Reference Manual</i>. Specify Elmosoft color number.</p> <p>► See <i>Surface Materials Reference Manual</i>. Specify vinyl color number.</p> <p>► See <i>Understanding Customer's Own Material (COM)</i>, page 642.</p> <p>► See <i>Understanding Customer's Own Material (COM)</i>, page 642.</p> <p>Specify <i>with 4140 Arctic White Gloss</i>.</p> <p>Specify <i>with 4799 Platinum Metallic</i>.</p> <p>Specify plastic color number.</p> <p>Specify plastic color number.</p>
Cup Holder	• Cup holder	+\$ 52	Specify <i>with cup holder</i> .
Tablet Stand	• Tablet stand	+\$ 52	Specify <i>with tablet stand</i> .
Casters	<ul style="list-style-type: none"> • Hard casters No cost • Soft dual-wheel casters for use on hard floors +\$ 47 		Specify <i>with hard casters</i> . Specify <i>with soft casters</i> .
Glides	• Non-marring plastic glides	+\$ 47	Specify <i>with glides</i> .

Specification Information	
• Style Number	• U.S. Base Price
TS31209A	\$1000

Shortcut

X Base Chair



Standard Includes	Required to Specify
-------------------	---------------------

- | | | |
|--|--|---|
| <ul style="list-style-type: none"> ▶ Need help? Product details, page 328 | <ul style="list-style-type: none"> • Seat shell: plastic • Steel wire frame base: paint price group 1 • Standard glides • Ships fully assembled • Meets Cal. 117 requirements | <ol style="list-style-type: none"> 1 Style number 2 Paint color number for base 3 Plastic color number for shell 4 Options, if selected (see below) <ul style="list-style-type: none"> ▶ See <i>Surface Materials</i>, page 634. |
|--|--|---|

Options	U.S. Price	Required to Specify
---------	------------	---------------------

- | | | | |
|---------------------|-----------|--------|---------------------------------|
| Seat Cushion | • Cushion | +\$215 | Specify with soft, felt glides. |
|---------------------|-----------|--------|---------------------------------|

Tip: Upholstery is only applicable if seat cushion is a selected option.

Tip: Craft in upholstery cautions the use of stripes and patterns on Shortcut. Please use fabric database when specifying.

Surface Materials	Upholstery	U.S. Price	Required to Specify
-------------------	------------	------------	---------------------

- | | | | |
|--|--|---|--|
| <ul style="list-style-type: none"> • Fabric price group 1 • Fabric price group 2 • Fabric price group 3 • Fabric price group 4 • Fabric price group 5 • Fabric price group 6 • Fabric price group 7 • Fabric price group 8 • Fabric price group 9 • Fabric price group 10 • Steelcase leather • Select Surfaces leather price group 1 • Elmosoft leather • Select Surfaces leather price group 2 • Vinyl • Customer's Own Material (COM) | <ul style="list-style-type: none"> • Customer's Own Leather (COL) | <ul style="list-style-type: none"> No cost +\$ 16 +\$ 37 +\$ 53 +\$ 62 +\$ 77 +\$ 94 +\$113 +\$140 +\$162 +\$136 +\$136 +\$160 +\$160 +\$ 16 +\$ 56 | <ul style="list-style-type: none"> Specify fabric color number. Specify fabric color number. Specify fabric color number. Specify fabric color number. Specify fabric color number. Specify fabric color number. Specify fabric color number. Specify fabric color number. Specify fabric color number. Specify fabric color number. Specify leather color number. ▶ See <i>Surface Materials Reference Manual</i>. Specify Elmosoft color number. ▶ See <i>Surface Materials Reference Manual</i>. Specify vinyl color number. ▶ See <i>Understanding Customer's Own Material (COM)</i>, page 642. ▶ See <i>Understanding Customer's Own Material (COM)</i>, page 642. |
|--|--|---|--|

Base	U.S. Price	Required to Specify
------	------------	---------------------

- | | | |
|-----------------------|---------|-----------------------------|
| • Paint price group 1 | No cost | Specify paint color number. |
| • Paint price group 2 | +\$ 56 | Specify paint color number. |
| • Paint price group 3 | +\$ 86 | Specify paint color number. |

Shell	U.S. Price	Required to Specify
-------	------------	---------------------

- | | | |
|-------------------------|---------|-------------------------------|
| • Plastic price group 1 | No cost | Specify plastic color number. |
| • Plastic price group 2 | +\$ 53 | Specify plastic color number. |

- | | | | |
|---------------|---------------------|---------|---------------------------------|
| Glides | • Soft, felt glides | No cost | Specify with soft, felt glides. |
|---------------|---------------------|---------|---------------------------------|

Specification Information	
Style Number	U.S. Base Price

TS31204A	\$582
----------	-------

▶ Detailed dimensions, page 334



For Canadian Pricing
 Multiply U.S. Price by the Canadian price factor.
 ▶ See page 1 for details.

Shortcut

X Base Stool



Tip: Upholstery is only applicable if seat cushion is a selected option.

Tip: Craft in upholstery cautions the use of stripes and patterns on Shortcut. Please use fabric database when specifying.

Standard Includes		Required to Specify
-------------------	--	---------------------

- | | | |
|--|--|---|
| <ul style="list-style-type: none"> ▶ Need help? Product details, page 328 | <ul style="list-style-type: none"> • Seat shell: plastic • Steel wire frame base: paint price group 1 • Standard glides • Ships fully assembled • Meets Cal. 117 requirements | <ol style="list-style-type: none"> 1 Style number 2 Paint color number for base 3 Plastic color number for shell 4 Options, if selected (see below) <ul style="list-style-type: none"> ▶ See <i>Surface Materials</i>, page 634. |
|--|--|---|

Options	U.S. Price	Required to Specify
---------	------------	---------------------

- | | | | |
|---------------------|---|--------|--|
| Seat Cushion | <ul style="list-style-type: none"> • Cushion | +\$215 | Specify <i>with cushion</i> and specify fabric color number. |
|---------------------|---|--------|--|

Surface Materials	Upholstery	U.S. Price	Required to Specify
-------------------	------------	------------	---------------------

- | | | | |
|--|--|---|--|
| | <ul style="list-style-type: none"> • Fabric price group 1 • Fabric price group 2 • Fabric price group 3 • Fabric price group 4 • Fabric price group 5 • Fabric price group 6 • Fabric price group 7 • Fabric price group 8 • Fabric price group 9 • Fabric price group 10 • Steelcase leather • Select Surfaces leather price group 1 • Elmosoft leather • Select Surfaces leather price group 2 • Vinyl • Customer's Own Material (COM) | <ul style="list-style-type: none"> No cost +\$ 16 +\$ 37 +\$ 53 +\$ 62 +\$ 77 +\$ 94 +\$113 +\$140 +\$162 +\$136 +\$136 +\$160 +\$160 +\$ 16 +\$ 56 | <ul style="list-style-type: none"> Specify fabric color number. Specify fabric color number. Specify fabric color number. Specify fabric color number. Specify fabric color number. Specify fabric color number. Specify fabric color number. Specify fabric color number. Specify fabric color number. Specify fabric color number. Specify leather color number. ▶ See <i>Surface Materials Reference Manual</i>. Specify Elmosoft color number. ▶ See <i>Surface Materials Reference Manual</i>. Specify vinyl color number. ▶ See <i>Understanding Customer's Own Material (COM)</i>, page 642. ▶ See <i>Understanding Customer's Own Material (COM)</i>, page 642. |
|--|--|---|--|

Base

- | | | |
|-----------------------|---------|-----------------------------|
| • Paint price group 1 | No cost | Specify paint color number. |
| • Paint price group 2 | +\$ 56 | Specify paint color number. |
| • Paint price group 3 | +\$ 86 | Specify paint color number. |

Shell

- | | | |
|-------------------------|---------|-------------------------------|
| • Plastic price group 1 | No cost | Specify plastic color number. |
| • Plastic price group 2 | +\$ 53 | Specify plastic color number. |

- | | | | |
|---------------|---|---------|---|
| Glides | <ul style="list-style-type: none"> • Soft, felt glides | No cost | Specify <i>with soft, felt glides</i> . |
|---------------|---|---------|---|

Specification Information

Style Number	U.S. Base Price
TS31 205B	\$863

▶ Detailed dimensions, page 334



For Canadian Pricing

Multiply U.S. Price by the Canadian price factor.

▶ See page 1 for details.

Shortcut

Wood Chair

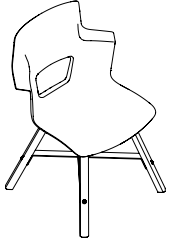

Standard Includes	Required to Specify
-------------------	---------------------

<ul style="list-style-type: none"> ▶ Need help? Product details, page 328 	<ul style="list-style-type: none"> • Seat shell: plastic • Solid maple legs: wood stain • Steel brackets: paint group 1 • Standard glides • Ships fully assembled • Meets Cal. 117 requirements 	<ol style="list-style-type: none"> 1 Style number 2 Plastic color number for shell 3 Wood stain color number for legs: <ul style="list-style-type: none"> V1AC Natural Cherry V1AM Clear Maple VICC Medium Amber Cherry V1EW Dark Walnut 4 Paint color number for brackets 5 Options, if selected (see below) <ul style="list-style-type: none"> ▶ See <i>Surface Materials</i>, page 634.
--	---	---

Options	U.S. Price	Required to Specify
---------	------------	---------------------

Seat Cushion	<ul style="list-style-type: none"> • Cushion 	+\$215	Specify <i>with cushion</i> and specify fabric color number.
---------------------	---	--------	--

Tip: Upholstery is only applicable if seat cushion is a selected option.

Tip: Craft in upholstery cautions the use of stripes and patterns on Shortcut. Please use fabric database when specifying.

Surface Materials	Upholstery	U.S. Price	Required to Specify
-------------------	------------	------------	---------------------

<ul style="list-style-type: none"> • Fabric price group 1 • Fabric price group 2 • Fabric price group 3 • Fabric price group 4 • Fabric price group 5 • Fabric price group 6 • Fabric price group 7 • Fabric price group 8 • Fabric price group 9 • Fabric price group 10 • Steelcase leather • Select Surfaces leather price group 1 • Elmosoft leather • Select Surfaces leather price group 2 • Vinyl • Customer's Own Material (COM) 	<ul style="list-style-type: none"> • Customer's Own Leather (COL) 	<ul style="list-style-type: none"> No cost +\$ 16 +\$ 37 +\$ 53 +\$ 62 +\$ 77 +\$ 94 +\$113 +\$140 +\$162 +\$136 +\$136 +\$160 +\$160 +\$ 16 +\$ 56 +\$ 56 	<ul style="list-style-type: none"> Specify fabric color number. Specify fabric color number. Specify fabric color number. Specify fabric color number. Specify fabric color number. Specify fabric color number. Specify fabric color number. Specify fabric color number. Specify fabric color number. Specify fabric color number. Specify leather color number. ▶ See <i>Surface Materials Reference Manual</i>. Specify Elmosoft color number. ▶ See <i>Surface Materials Reference Manual</i>. Specify vinyl color number. ▶ See <i>Understanding Customer's Own Material (COM)</i>, page 642. ▶ See <i>Understanding Customer's Own Material (COM)</i>, page 642.
--	--	---	--

Shell	<ul style="list-style-type: none"> • Plastic price group 1 • Plastic price group 2 	<ul style="list-style-type: none"> No cost +\$ 53 	<ul style="list-style-type: none"> Specify plastic color number. Specify plastic color number.
--------------	--	---	--

Brackets	<ul style="list-style-type: none"> • Paint price group 1 • Paint price group 2 • Paint price group 3 	<ul style="list-style-type: none"> No cost +\$ 56 +\$ 86 	<ul style="list-style-type: none"> Specify paint color number. Specify paint color number. Specify paint color number.
-----------------	---	---	---

Related Products	<ul style="list-style-type: none"> • Shortcut X Base chair and stool 	▶ Pages 339–340
-------------------------	---	-----------------

Specification Information

Style Number	U.S. Base Price
TS31 206A	\$1232

▶ Detailed dimensions, page 334

For Canadian Pricing
 Multiply U.S. Price by the Canadian price factor.
 ▶ See page 1 for details.

Shortcut

with Tripod Base

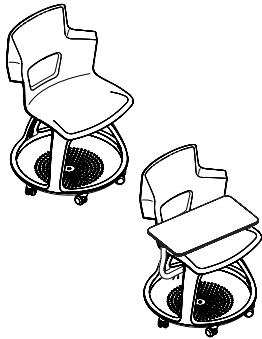

Tip: Metal components include shell bracket and personal worksurface arm if TS31208A is selected.

Tip: Upholstery is only applicable if seat cushion is a selected option.

Tip: Craft in upholstery cautions the use of stripes and patterns on Shortcut. Please use fabric database when specifying.

Tip: Cup Holder and Tablet Stand are only available on Shortcut with a Personal Worksurface.

► Detailed dimensions, page 334



For Canadian Pricing

Multiply U.S. Price by the Canadian price factor.

► See page 1 for details.

Standard Includes		Required to Specify
► Need help? Product details, page 330	<ul style="list-style-type: none"> • Seat shell: plastic • Tripod base: plastic • Metal components: paint • Storage tray: sterling dark solid only • Swivel seat • Personal Worksurface, if TS31208A selected: plastic • Hard casters: black • Ships ready to assemble • Meets Cal. 117 requirements 	<ol style="list-style-type: none"> 1 Style number 2 Plastic color number for shell 3 Plastic color number for tripod base 4 Paint number for metal components: 0835 Black 4140 Arctic White 4799 Platinum Metallic 5 Plastic color number for Personal Worksurface, if selected 6 Options, if selected (see below) <p>► See <i>Surface Materials</i>, page 634.</p>
Options	U.S. Price	Required to Specify
Surface Materials	Upholstery on seat cushion	
	<ul style="list-style-type: none"> • Fabric price group 1 No cost • Fabric price group 2 +\$ 16 • Fabric price group 3 +\$ 37 • Fabric price group 4 +\$ 53 • Fabric price group 5 +\$ 62 • Fabric price group 6 +\$ 77 • Fabric price group 7 +\$ 94 • Fabric price group 8 +\$113 • Fabric price group 9 +\$140 • Fabric price group 10 +\$162 • Steelcase leather +\$136 • Select Surfaces leather price group 1 +\$136 • Elmosoft leather +\$160 • Select Surfaces leather price group 2 +\$160 • Customer's Own Material (COM) +\$ 56 • Vinyl +\$ 16 	Specify fabric color number. Specify fabric color number. Specify fabric color number. Specify fabric color number. Specify fabric color number. Specify fabric color number. Specify fabric color number. Specify fabric color number. Specify fabric color number. Specify fabric color number. Specify fabric color number. Specify leather color number. ► See <i>Surface Materials Reference Manual</i> . Specify Elmosoft color number. ► See <i>Surface Materials Reference Manual</i> . ► See <i>Understanding Customer's Own Material (COM)</i> , page 642. Specify vinyl color number. ► See <i>Understanding Customer's Own Material (COM)</i> , page 642.
	Shell	
	<ul style="list-style-type: none"> • Plastic price group 1 No cost • Plastic price group 2 +\$ 53 	Specify plastic color number. Specify plastic color number.
Seat Cushion	<ul style="list-style-type: none"> • Cushion +\$215 	Specify <i>with cushion</i> and specify fabric color number.
Cup Holder	<ul style="list-style-type: none"> • On TS31208A +\$ 53 	Specify <i>with cup holder</i> .
Tablet Stand	<ul style="list-style-type: none"> • On TS31208A +\$ 53 	Specify <i>with tablet stand</i> .
Casters	<ul style="list-style-type: none"> • Soft, dual-wheel casters for use on hard floors +\$ 47 	Specify <i>with soft casters</i> .
Glides	<ul style="list-style-type: none"> • Glides: sterling dark solid +\$ 37 	Specify <i>with glides</i> .
Related Products	<ul style="list-style-type: none"> • Shortcut Cushions • Shortcut Five-Star Base Chair and Stool • Shortcut X-Base Chair and Stool 	► Page 344 ► Pages 336–337 ► Pages 339–340

Specification Information

• Style	• U.S.
• Number	• Base
•	• Price

Chair with Tripod Base

TS31207A	\$ 707
-----------------	--------

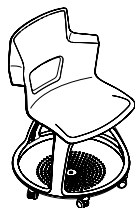

Chair with Tripod Base and Personal Worksurface

TS31208A	\$1036
-----------------	--------

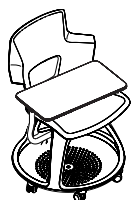

► Detailed dimensions, page 334



For Canadian Pricing

Multiply U.S. Price by the Canadian price factor.

► See page 1 for details.

Shortcut

Cushion



Tip: Cushion can be optioned on when ordering any Shortcut chair or stool, or installed after purchase when ordered separately.

Standard Includes	Required to Specify
-------------------	---------------------

- | | | |
|--|---|--|
| ▶ Need help? Product details, page 324 | <ul style="list-style-type: none"> • Cushion: fabric price group 1 • Shipped ready to assemble • Meets Cal. 117 requirements | <ul style="list-style-type: none"> 1 Style number 2 Fabric color number for cushion 3 Options, if selected (see below) ▶ See <i>Surface Materials</i>, page 634. |
|--|---|--|

Surface Materials	Options	U.S. Price	Required to Specify
-------------------	---------	------------	---------------------

Surface Materials	Options	U.S. Price	Required to Specify
	Upholstery		
	• Fabric price group 1	No cost	Specify fabric color number.
	• Fabric price group 2	+\$ 16	Specify fabric color number.
	• Fabric price group 3	+\$ 37	Specify fabric color number.
	• Fabric price group 4	+\$ 53	Specify fabric color number.
	• Fabric price group 5	+\$ 62	Specify fabric color number.
	• Fabric price group 6	+\$ 77	Specify fabric color number.
	• Fabric price group 7	+\$ 94	Specify fabric color number.
	• Fabric price group 8	+\$113	Specify fabric color number.
	• Fabric price group 9	+\$140	Specify fabric color number.
	• Fabric price group 10	+\$162	Specify fabric color number.
	• Steelcase leather	+\$136	Specify leather color number.
	• Select Surfaces leather price group 1	+\$136	▶ See <i>Surface Materials Reference Manual</i> .
	• Elmosoft leather	+\$160	Specify Elmosoft color number.
	• Select Surfaces leather price group 2	+\$160	▶ See <i>Surface Materials Reference Manual</i> .
	• Vinyl	+\$ 16	Specify vinyl color number.
	• Customer's Own Material (COM)	+\$ 56	▶ See <i>Understanding Customer's Own Material (COM)</i> , page 642.
	• Customer's Own Leather (COL)	+\$ 56	▶ See <i>Understanding Customer's Own Material (COM)</i> , page 642.

Specification Information

• Style Number	• U.S. Base Price
TS31203	\$215

▶ Detailed dimensions, page 334



For Canadian Pricing

Multiply U.S. Price by the Canadian price factor.

▶ See page 1 for details.