

Answer Solutions Specification Guide

Availability

Electronic price list updated with release 200.M (U.S.) and 156.M (Canada), dated June 17, 2024.

All specifications subject to change without notice. Reference the electronic catalog/Hedberg for current pricing.

Transitional products in this specification guide are **maintained for existing customers only** and are likely to be phased out over time. These products are indicated with a **T**. Products that are scheduled to be culled are indicated with an **X**, followed by the last order entry date.

Surface Materials

The surface materials team has announced the launch of the Finish Library, found at www.steelcase.com/finishlibrary/.

► For a list of all trademarks, refer to the last page of this specification guide. © 2024 Steelcase Inc.



For Canadian Pricing

Canadian factor can be found at www.steelcase.com/CADpricing/. Calculate in the following order to avoid rounding errors:

- Multiply the base price and each option by the Canadian factor.
- Round each to the nearest dollar.
- Add base and options for total list price.

Working With This Specification Guide

Ten Tips: How to Get the Most Out of This Book	2
Additional Resources	4

Understanding

Panels—Thin Trim	5
Panels—Square and Oval Trim	85
Shared Components	111
Wiring and Cabling	157
Universal Systems Worksurfaces and Supports	185
Worksurface Screens	233
Universal Tables	243
Answer Monitor Mount Integration	257
Counterweights	263
Universal Steel Storage Products	273
High-Density Storage Products	307
Duo Storage Products	315

Specifying

Panels—Thin Trim	321
Panels—Square and Oval Trim	401
Shared Components and Wiring and Cabling	435
Universal Systems Worksurfaces and Supports	499
Worksurface Screens	561
Worksurface Power and Communication	573
Universal Tables	579
Answer Monitor Mount Integration	595
Universal Steel Storage Products	597
High-Density Storage Products	639
Storage Tops, Shelves, and Accessories	647
Duo Storage Products	663

Surface Materials

Resources	685
------------------	------------

Ten Tips: How to Get the Most Out of This Book

Tip 1

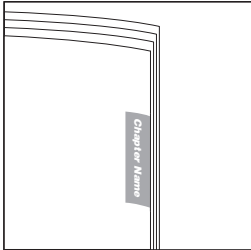

Watch the tabs on the right-hand edges of the pages. They'll always indicate which chapter you are in.

Tip 2

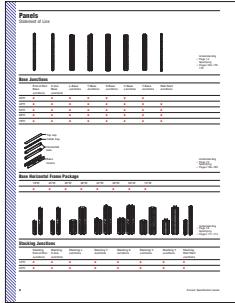

Use the Statement of Line pages for an overview of the available components, their sizes, and page references for additional information. Each *Understanding* chapter includes a statement of line after the table of contents.

Tip 3



Find cross references by looking for page numbers flagged with an arrow.

Tip 4

Study the product detail pages in the *Understanding* section to learn everything an expert knows about specific products. Each product detail page in this section contains the following features, where applicable:

- Product Drawing
- Actual Dimensions
- Product Details
- Connections
- Wiring and Cabling
- Surface Materials
- Application Topics

Product Drawing shows you what the product looks like and points out important features.

Product Details gives specific information on the product and how it is used.

Connections describes how the product is assembled or how it attaches to another product.

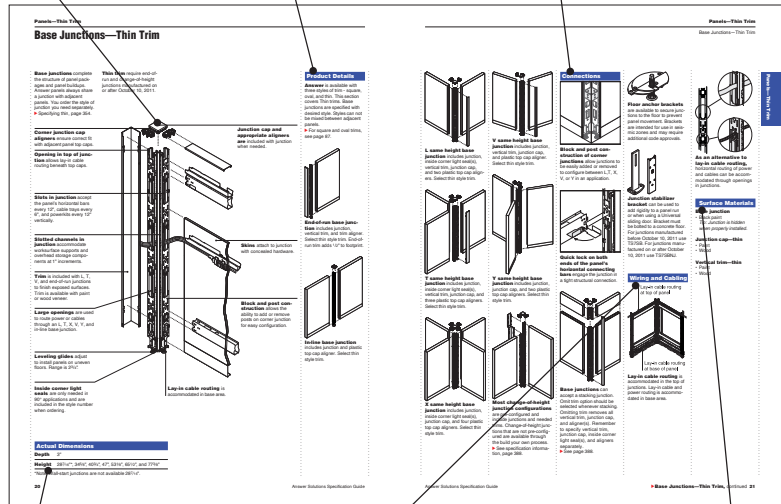

Actual Dimensions table lists the dimensions of the product.

Wiring and Cabling details the power and cable-management and cable routing capabilities of the product.

Surface Materials lists what material is used for each part of the product.

Tip 5

Refer to the specifying pages for all the information needed to order a product. Each product specifying page contains a variety of elements to help you complete a specification:

- Product Drawing
- Standard Includes
- Required to Specify
- Options
- Related Products
- Specification Information
 - Dimensions
 - Style Number
 - Price

Standard Includes (under the red or dark grey band) provides a list of what comes standard with the product.

Required to Specify (under the red or dark grey band) itemizes the information that you must provide to order the standard product and the preferred sequence for specification.

Specification Information (under the teal or light grey band) provides product dimensions, style numbers, and prices for the standard product and any surface material choices that are available.

Product Drawing shows you what the product looks like.

The screenshot shows a detailed specification page for 'Base Horizontal Frame Packages—Thin Trim'. It includes sections for 'Standard Includes', 'Required to Specify', 'Options', 'Specification Information', and 'Product Drawing'. Callouts from the surrounding text point to these specific areas on the page.

Options (under the black band) lists all the options that apply to the product, their price, and what is required to specify.

Related Products provide specification information for products that are directly related.

Tip 6

Required to Specify

Specify with *Customiz Stain*

Italic typeface on specifying pages usually identifies wording that you should use in your order.

i

Tip 7

To determine how many skins are needed to complete a panel, consult the table at the right.

Tip: Remember to order skins for both sides of the panel buildup.

Watch for tips throughout the text that give you explanations and helpful instructions.

Tip 8

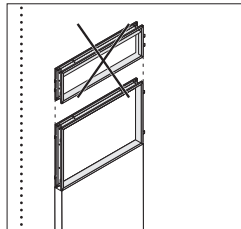

Learn what you cannot do by looking for drawings crossed out with an "X."

Tip 9

Use the surface materials listings in the Surface Materials section of this book to find surface material color numbers.

Tip 10

Style Number	Page
TS7042BL	131
TS7042S	130
TS7048BL	131
TS7048S	130
TS7060BL	131
TS7060S	130
TS7072BL	131

Refer to the style number index when you need a style number and you need to find the page that has more details about the product.

Additional Resources

Answer is supported with an array of informational materials, tools, and software to help you plan an installation efficiently.

Product brochures and planning tools can be ordered through your Steelcase area office by calling 1.800.784.0358 or through the Marketing Resources web site at village.steelcase.com.

Additional storage products can be found in the *Storage Specification Guide*.

Printed Materials

Answer Product Brochure

This resource is your single source for everything you need to sell Answer. It contains photography showcasing a range of aesthetic and planning options. A complete statement of line, which highlights worksurfaces and storage options, also is included.
Form number 11-2374

Storage Specification Guide contains storage that attaches to Answer and the full offering of large case storage for use outside of workstations.

Answer Freestanding Specification Guide contains lighting, wall-mount storage, screens, and wire management products.

Quick Ship Guide This handbook describes all Steelcase and Coalesse products that are available for Rapid2 (ships in 2 days), Rapid5 (ships in 5-7 days), or Coalesse Rapid10 (ships in 10 days).

Surface Materials Reference Manual This publication provides:

- An explanation of the surface materials
- "Available on" matrices
- Vertical surface fabric and seating upholstery selection listing
- Technical data for surface materials
- Surface material care and cleaning instructions

Computer Tools

Electronic Catalog Accurate sales quotations and purchase orders for Steelcase products are created with specification software that uses Steelcase Electronic Catalog data. Use the data to specify and price style numbers and options for every Steelcase product. The data is updated bimonthly by Steelcase and provided to software programs including: the Hedberg Business System, SmartTools – Steelcase's design and specification software (for more information on SmartTools, please email SmartTools@steelcase.com), the ProjectMatrix Project-Symbols libraries, as well as 20-20 CAP Studio.

Furniture Symbol Graphic Data Steelcase creates 2D and 3D furniture symbols (with attributes) for planning and initially specifying Steelcase products. This data is incorporated into several add-on software packages that work in either a Microstation or an AutoCAD drafting environment.

Digital Publications You can access these digital publications at www.steelcase.com or village.steelcase.com.

Answer Product Training Basic training for Answer and many other Steelcase products is available as part of the Building Product Muscle curriculum on the Steelcase University Web site at village.steelcase.com.

The Answer BPM web-based module is an interactive course filled with pictures, product detail, and practice exercises designed to build knowledge of Answer's positioning, statement of line, features and benefits, competitive products, application, and sales presentation. It also provides printable job aids of all content covered in the course to serve as ongoing performance support for Steelcase and dealer salespeople. The Answer BPM is course SAL140.

Planning Ideas

Planning ideas are available to help inspire, envision, and plan great solutions. 2D and 3D AutoCAD drawings, Sketch-Up files, and SmartTools drawings are available on the Planning Ideas site: www.steelcase.com/planningideas.

Support

Steelcase Capabilities Steelcase products are distributed, installed, and serviced through a network of more than 600 dealers worldwide. Steelcase is also represented with offices and corporate showrooms in 26 U.S. cities, 4 Canadian cities, and in France, Germany, Great Britain, and Japan. Every Steelcase product meets our exceptionally high standards of quality and durability and comes with the Steelcase assurance of excellence in service.

For ordering or product assistance, call your local dealer, the Steelcase Solutions Resource Team, or the Steelcase Solutions Fulfillment Team at 1.888.STEELCASE (1.888.783.3522) or send an e-mail to lineone@steelcase.com.

Call the Steelcase Solutions Resource Team prior to placing an order, when working on a bid, or when you need information about product applications and specifications.

Call the Steelcase Solutions Fulfillment Team if you have submitted an order to Steelcase and you need to speak to your Solutions Fulfillment Team Representative about the order. Also call if you have any post-shipment quality concerns or service parts questions.

For warranty information, please go to <http://www.steelcase.com/warranty/>.

Outside the U.S.A., Canada, Mexico, Puerto Rico, and the U.S. Virgin Islands, call 1.616.247.2500.

Related Products

Worktools include a full line of ergonomically designed products that enhances and improves the work setting. Product platforms include computer support tools, organizational worktools, and personal lighting.
► For additional information, refer to *Steelcase Worktools Specification Guide* or contact Steelcase at 1.888.STEELCASE (1.888.783.3522) or send an email to lineone@steelcase.com.

Height-adjustable desks include a full line of crank, counterbalance, and electric height-adjustable desks which promote well-being in the office.
► For additional information, refer to *Height-Adjustable Desks Specification Guide* or call 1.888.STEELCASE or send an email to lineone@steelcase.com.

Answer Assembly Tool As an alternative to using a rubber mallet, frames can be assembled using the Answer Assembly Tool. Call Steelcase for pricing and order information. 1.888.STEELCASE (1.888.783.3522) or send an email to lineone@steelcase.com.

Sustainability

At Steelcase, we believe business can be a force for good. We create long-lasting products that are better for people and better for the planet. Our products and operations use life cycle thinking to meet our commitment to reducing climate change. This commitment is reinforced by practices such as designing to minimize global warming and other life cycle impacts, ensuring material health, and enabling end-of-use strategies. To learn more at a corporate level, visit: <https://www.steelcase.com/discover/steelcase/esg-overview/environmental/Product-Environmental-Profiles>, which provide key environmental attributes such as recycled content, embodied carbon and recyclability, as well as product certifications can be found by searching for Steelcase at *Origin.build*.

Understanding Panels—Thin Trim

Statement of Line 6

Product Details

Answer Panel Overview—Thin Trim	16
Panel Buildups	18
Base Junctions—Thin Trim	20
Change-of-Height—Thin Trim	24
Change-of-Height Visual Overview—Thin Trim	26
Off-Module Panel Connector—Thin Trim	30
Stacking Junctions—Thin Trim	32
Build Your Own Elements—Thin Trim	35
Build Your Own Change-of-Height—Thin Trim	40
Practice Examples—Thin Trim	45
Build Your Own 3" In-Line Junction—Thin Trim	46
Build Your Own Stacking Junctions—Thin Trim	48
Reconfiguring with Answer—General Guidelines	52
Base Horizontal Frame Packages—Thin Trim	58
Stacking Horizontal Frame Packages	62
Frameless Glass Screens with Recessed Attachment—Thin Trim	64
Frameless Glass Screens with Clip Attachment—Thin Trim	68
Universal Screens with Answer Thin Trim Top Cap	70
Sarto Fence Screens with Answer Thin Trim Top Cap	72
Top Cap Mounted Storage	74
Panel Packages—Thin Trim	78
Answer Boundary Screens	80
Stability Guidelines	140

Statement of Line



Understanding
 ▶ Page 20
 Specifying
 ▶ Pages 322–326

Base Junctions—Thin Trim

	In-Line Base Junctions	L-Base Junctions	T-Base Junctions	X-Base Junctions	End-of-Run Base Junctions	V-Base Junctions	Y-Base Junctions	Wall-Start Junctions
30"	●	●	●	●	●	●	●	●
36"	●	●	●	●	●	●	●	●
42"	●	●	●	●	●	●	●	●
48"	●	●	●	●	●	●	●	●
54"	●	●	●	●	●	●	●	●
66"	●	●	●	●	●	●	●	●
78"	●	●	●	●	●	●	●	●



Understanding
 ▶ Page 24
 Specifying
 ▶ Pages 327–340

Change-of-Height Junctions—Thin Trim

In-Line Change-of-Height Junction	L Change-of-Height Junction	T Change-of-Height Junction	X Change-of-Height Junction	V Change-of-Height Junction	Y Change-of-Height Junction
●	●	●	●	●	●

Note: Accommodates most panel heights and combinations.
 ▶ See Change-of-Height Visual Overview—Thin Trim, page 26.



Understanding
 ▶ Page 32
 Specifying
 ▶ Pages 345–346

Stacking Junctions—Thin Trim

	Stacking In-Line Junctions	Stacking L Junctions	Stacking T Junctions	Stacking X Junctions	Stacking End-of-Run Junctions	Stacking V Junctions	Stacking Y Junctions	Wall-Start Junction
6"	●	●	●	●	●	●	●	●
12"	●	●	●	●	●	●	●	●
18"	●	●	●	●	●	●	●	●
24"	●	●	●	●	●	●	●	●

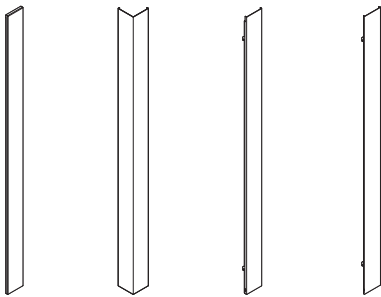

Understanding
 ▶ Pages 37–38
 Specifying
 ▶ Page 350

Vertical Trim—Thin Trim

	End-of-Run Vertical Trim	L Vertical Trim	T Vertical Trim	V Vertical Trim
30"	●	●	●	●
36"	●	●	●	●
42"	●	●	●	●
48"	●	●	●	●
54"	●	●	●	●
60"	●	●	●	●
66"	●	●	●	●
72"	●	●	●	●
78"	●	●	●	●
84"	●	●	●	●
90"	●	●	●	●



Understanding
 ▶ Pages 38–39
 Specifying
 ▶ Page 353

Change-of-Height—Thin Trim

	End-of-Run Change-of-Height	L Corner Change-of-Height	T Corner Change-of-Height	120° Corner Change-of-Height	V Change-of-Height
6"	●	●	●	●	●
12"	●	●	●	●	●
18"	●	●	●	●	●
24"	●	●	●	●	●
30"	●	●	●	●	●
36"	●	●	●	●	●

Note: For all change-of-height trim, see Change-of-Height—Thin Trim on page 38.

Statement of Line, continued



Understanding
 ▶ Page 35
 Specifying
 ▶ Page 356

Junction Posts

30"	36"	42"	48"	54"	66"	78"
●	●	●	●	●	●	●



Understanding
 ▶ Page 35
 Specifying
 ▶ Page 357

Junction Blocks

90° Corner	120° Corner
●	●



Understanding
 ▶ Page 35
 Specifying
 ▶ Page 357

Inside Corner Light Seals

54"	66"	78"
●	●	●



Understanding
 ▶ Page 36
 Specifying
 ▶ Page 359

Junction Caps

90° Corner Junction Cap	120° Corner Junction Cap	90° Change-of-Height Junction Cap	Junction Cap Corner Aligner
●	●	●	●

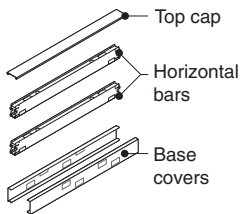

Understanding
 ▶ Page 58
 Specifying
 ▶ Page 360

Base Horizontal Frame Packages—Thin Trim

18"	24"	30"	36"	42"	48"	60"	72"
●	●	●	●	●	●	●	●

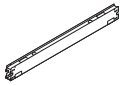

Understanding
 ▶ Page 62
 Specifying
 ▶ Page 362

Stacking Horizontal Frame Packages

18"W	24"W	30"W	36"W	42"W	48"W	60"W	72"W
●	●	●	●	●	●	●	●

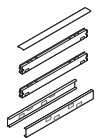

Horizontal frame package

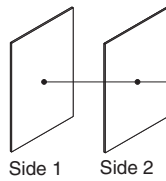

Performance Tackable Acoustical Skins

Understanding
 ▶ Page 78
 Specifying
 ▶ Page 374

Performance Tackable Acoustical Panel Packages—Thin Trim

	18"W	24"W	30"W	36"W	42"W	48"W	60"W	72"W
42"H	●	●	●	●	●	●	●	●
48"H	●	●	●	●	●	●	●	●
54"H	●	●	●	●	●	●	●	●
66"H	●	●	●	●	●	●	●	●

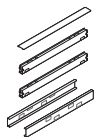

Horizontal frame package

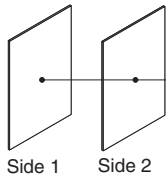

Tackable Acoustical Skins

Understanding
 ▶ Page 78
 Specifying
 ▶ Page 374

Tackable Acoustical Panel Packages—Thin Trim

	18"W	24"W	30"W	36"W	42"W	48"W	60"W	72"W
42"H	●	●	●	●	●	●	●	●
48"H	●	●	●	●	●	●	●	●
54"H	●	●	●	●	●	●	●	●
66"H	●	●	●	●	●	●	●	●

Panels—Thin Trim

Statement of Line, continued

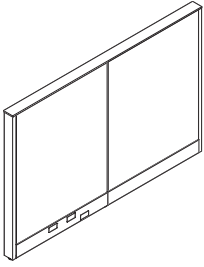

Understanding
 ▶ Page 58
 Specifying
 ▶ Page 363

Spanning Top Caps—Thin Trim

36"W 42"W 48"W 60"W 72"W 78"W 84"W 90"W 96"W

•	•	•	•	•	•	•	•	•
---	---	---	---	---	---	---	---	---

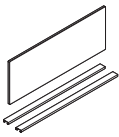

Understanding
 ▶ Page 64
 Specifying
 ▶ Page 364

Frameless Glass Screens with Recessed Attachment—Thin Trim

	24"W	30"W	36"W	42"W	48"W	54"W	60"W	66"W	72"W	78"W	84"W	90"W	96"W
6"H	•	•	•	•	•	•	•	•	•	•	•	•	•
12"H	•	•	•	•	•	•	•	•	•	•	•	•	•
18"H	•	•	•	•	•	•	•	•	•	•	•	•	•
24"H	•	•	•	•	•	•	•	•	•	•	•	•	•

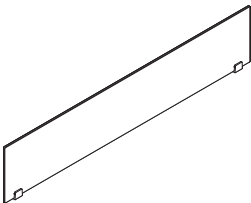

Understanding
 ▶ Page 68
 Specifying
 ▶ Page 368

Frameless Glass Screens with Clip Attachment—Thin Trim

	24"W	30"W	36"W	42"W	48"W	60"W	72"W	78"W	84"W	90"W	96"W
12"H	•	•	•	•	•	•	•	•	•	•	•

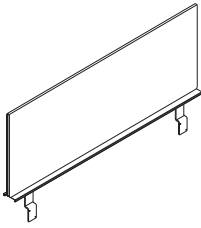

Understanding
 ▶ Page 70
 Specifying
 ▶ Page 370

Universal Screens with Answer Thin Trim Top Cap

	24"W	30"W	36"W	42"W	48"W	54"W	60"W	66"W	72"W	78"W	84"W	90"W	96"W
13 1/2"H	•	•	•	•	•	•	•	•	•	•	•	•	•
19 1/2"H	•	•	•	•	•	•	•	•	•	•	•	•	•

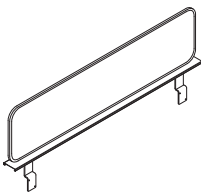

Understanding
 ▶ Page 72
 Specifying
 ▶ Page 370

Sarto Fence Screens with Answer Thin Trim Top Cap

	24"W	30"W	36"W	42"W	48"W	54"W	60"W	66"W	72"W	78"W	84"W	90"W	96"W
13 1/2"H	•	•	•	•	•	•	•	•	•	•	•	•	•
19 1/2"H	•	•	•	•	•	•	•	•	•	•	•	•	•



Center Mount Bracket



Aisle Mount Bracket

Understanding
 ▶ Page 74
 Specifying
 ▶ Page 372

Top Cap Mounted Storage—Center Mounted and Aisleway

30"W	36"W	42"W	48"W	54"W	60"W	66"W	72"W (Width of storage unit)
•	•	•	•	•	•	•	•

Straight Boundary Screens

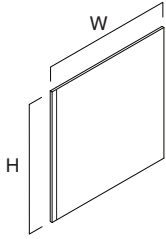

Understanding
 ▶ Page 80
 Specifying
 ▶ Pages 376 and 380

Single-Sided Boundary Screens

	27"W	33"W	39"W	45"W	51"W	57"W	63"W	69"W	75"W
30"H	●	●	●	●	●	●	●	●	●
36"H	●	●	●	●	●	●	●	●	●
42"H	●	●	●	●	●	●	●	●	●
48"H	●	●	●	●	●	●	●	●	●
54"H	●	●	●	●	●	●	●	●	●

Tip: Single-sided boundary screens are available in both single-connect and dual-connect.

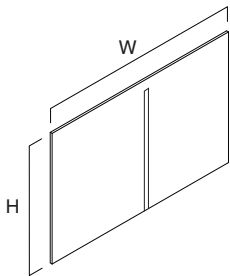

Understanding
 ▶ Page 80
 Specifying
 ▶ Pages 376 and 380

Spanning Boundary Screens

	51"W	57"W	63"W	69"W	75"W
30"H	●	●	●	●	●
36"H	●	●	●	●	●
42"H	●	●	●	●	●
48"H	●	●	●	●	●
54"H	●	●	●	●	●

Tip: Spanning boundary screens are available in both single-connect and dual-connect.

Straight Boundary Screens, continued

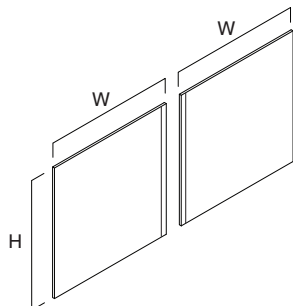

Understanding
 ▶ Page 80
 Specifying
 ▶ Pages 376 and 380

Split Boundary Screens

	25 ¹ / ₂ "W	31 ¹ / ₂ "W	37 ¹ / ₂ "W	43 ¹ / ₂ "W	49 ¹ / ₂ "W	55 ¹ / ₂ "W	61 ¹ / ₂ "W	67 ¹ / ₂ "W	73 ¹ / ₂ "W
30"H	●	●	●	●	●	●	●	●	●
36"H	●	●	●	●	●	●	●	●	●
42"H	●	●	●	●	●	●	●	●	●
48"H	●	●	●	●	●	●	●	●	●
54"H	●	●	●	●	●	●	●	●	●

Tip: Split boundary screens are available in both single-connect and dual-connect.
Tip: Width must be specified for each split segment.

L Return Single-Sided Boundary Screens

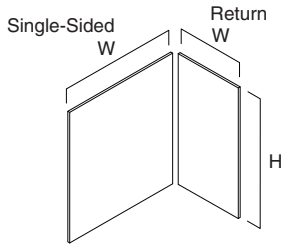

Understanding
 ▶ Page 80
 Specifying
 ▶ Pages 384 and 392

Single-Sided Screens (Primary Screens)

	27"W	33"W	39"W	45"W	51"W	57"W	63"W	69"W	75"W
30"H	●	●	●	●	●	●	●	●	●
36"H	●	●	●	●	●	●	●	●	●
42"H	●	●	●	●	●	●	●	●	●
48"H	●	●	●	●	●	●	●	●	●
54"H	●	●	●	●	●	●	●	●	●

Return Screens

	18"W	24"W	30"W
30"H	●	●	●
36"H	●	●	●
42"H	●	●	●
48"H	●	●	●
54"H	●	●	●

*Tip: L return single-sided boundary screens are available in both single-connect and dual-connect.
 Tip: Primary and return screens may be specified with equal or unequal widths.*

L Return Split Boundary Screens

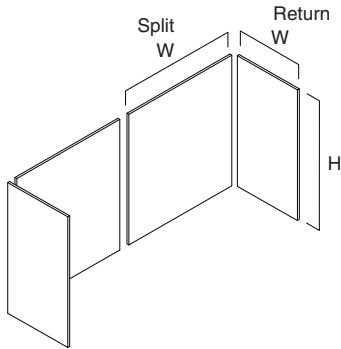

Understanding
 ▶ Page 80
 Specifying
 ▶ Pages 384 and 392

Split Screens (Primary Screens)

	25 1/2"W	31 1/2"W	37 1/2"W	43 1/2"W	49 1/2"W	55 1/2"W	61 1/2"W	67 1/2"W	73 1/2"W
30"H	●	●	●	●	●	●	●	●	●
36"H	●	●	●	●	●	●	●	●	●
42"H	●	●	●	●	●	●	●	●	●
48"H	●	●	●	●	●	●	●	●	●
54"H	●	●	●	●	●	●	●	●	●

Return Screens

	18"W	24"W	30"W
30"H	●	●	●
36"H	●	●	●
42"H	●	●	●
48"H	●	●	●
54"H	●	●	●

Tip: L return split boundary screens are available in both single-connect and dual-connect.

Tip: Width must be specified for each split segment.

Tip: Primary and return screens may be specified with equal or unequal widths.

Answer Panel Overview—Thin Trim

Thin, square, and oval trim styles are available on Answer panels. Trim styles are not compatible with each other. Applications must use one consistent trim style.

Panel buildups allow you to create unique configurations by mixing surface materials and colors on segmented panels. Order skins and horizontal frame packages separately.

Panel frame is made up of two major elements—vertical base junctions and base horizontal connecting bars.

Stacking components can be used on both panel buildups and panel packages.

Panel packages are used to create common configurations quickly and easily. Packages include a horizontal frame package and skins for both sides of the panel.

Stacking junctions do not come with trim. Vertical trim must be ordered separately to cover any exposed junctions.
▶ Page 32

Stacking horizontal frame package must be used with stacking junctions.
▶ Page 62

Stacking junctions can be used in panel buildups and panel packages. They are available for in-line, L, T, X, V, Y, and end-of-run configurations.
▶ Page 32

Skins attach to frame without tools and can be removed and repositioned easily.
▶ Page 118

Base junctions are always shared by adjacent panels. They are available for in-line, L, T, X, V, Y, and end-of-run configurations. Wall-start junctions and off-module connectors are also available.
▶ Page 20

Base trims, open base, or big open base trim styles are available on panels with Thin trim style.

Base horizontal connecting bars lock into the vertical junctions at the top and the bottom location of base junction to provide structural stability for the panels.

Thin end-of-run trim has an integral finished end.

Alternate powerkit harness routing can be accommodated through the junction opening. In in-line applications installed on uneven floors, route harness through junction opening to prevent harness from being exposed.

Leveling glides adjust to install panels on uneven floors. Range is 2³/₄".

Powerkits include powerblocks attached to a supporting power tray.
▶ Page 176

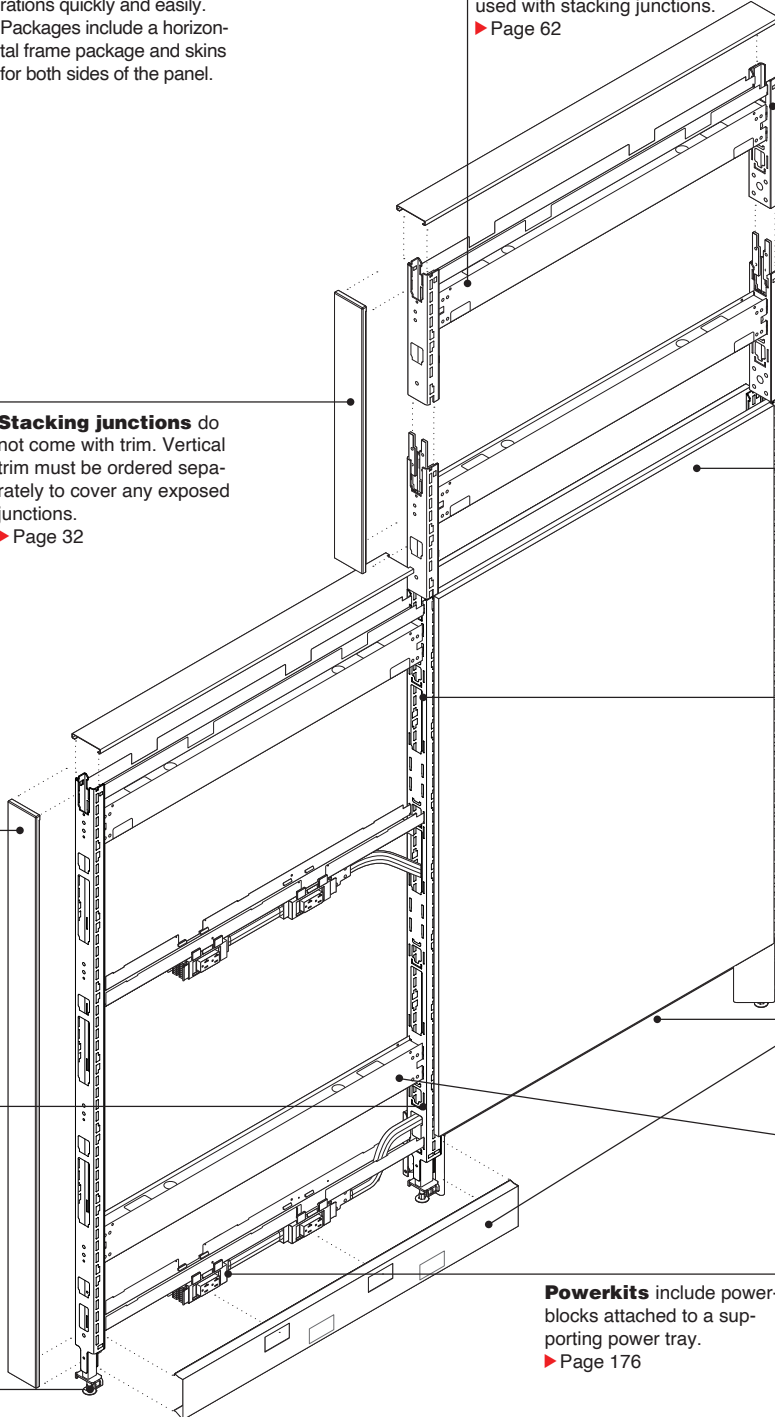

Actual Dimensions

Height 29¹/₂", 35¹/₁₆", 41⁷/₈", 48¹/₁₆", 54¹/₄", 66¹⁹/₃₂", and 78³¹/₃₂"

Note: Height is minimum from floor to top of top caps. Leveling glides can extend 2³/₄".

Panel Buildups

Order panel components separately to create unique configurations.

1. Begin by planning your frames. Junctions determine height and horizontal connecting bars determine width.

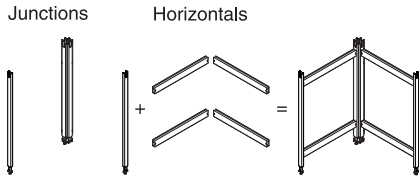

1a. Corner junctions can easily be reconfigured by adding or removing a junction post (available on junctions shipped on or after October 10, 2011).

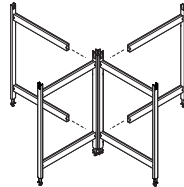

2. Order skins for both sides of panel.
Exception: Windows accommodate both sides of the panel.

Performance tackable acoustical fabric-covered skins

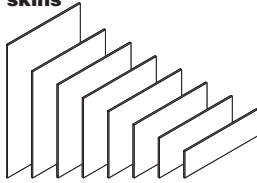

Tackable acoustical fabric-covered skins

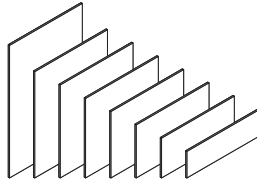

Steel skins (12"H, 18"H, and 24"H have ribbed and perforated options)

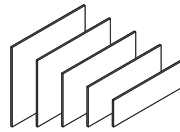

Laminate skins

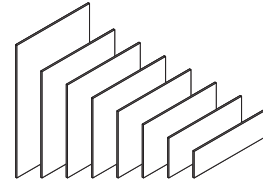

Wood skins

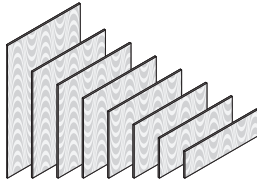

Tip: Wood skin sets are available for 42", 48", 54", and 66" panel heights.

Back painted glass skins

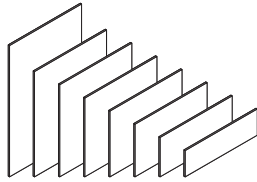

Markerboard skins

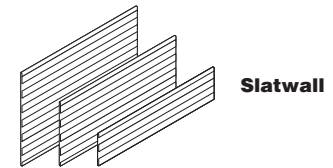
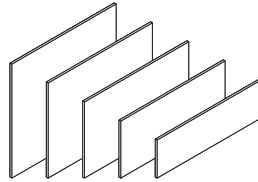

Slatwall



Windows



Technology skins

Answer allows a wide variety of skin arrangements to meet specific functional and aesthetic needs. Skins are not dedicated to a specific location and can be used anywhere on the face of the panel.

2. Order skins for both sides of panel, continued

When specifying skins, the total skin height will be 6" less than the overall panel height. For example, if the panel is 66"H the total skin height will be 60".

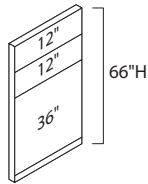

When planning skin segments, add skin heights together and add an additional 6" for total height.

Skins = 12" + 12" + 36" = 60"

Trim = 6"

Total = 66"H

Skins to the floor are available in fabric, steel, laminate, wood, or wood skin sets. Skins to the floor also plan 6" shorter than the height of the panel, but are taller in actual height to cover the base trim area of the panel. For example, a 54"H panel with to the floor skins would require a 48" skin with suffix "F", which would be approximately 53"H actual dimension.

Tip: Omit base trim option should be selected on the frame package when using a skin to the floor.

Panel Height	Total Standard Skin Height	Style Number	Total Skin To The Floor Height	Style Number
30"H Panel	24"	TS72430TK	24"	TS72430TKF
42"H Panel	36"	TS73630TK	36"	TS73630TKF
48"H Panel	42"	TS74230TK	42"	TS74230TKF
54"H Panel	48"	TS74830TK	48"	TS74830TKF
66"H Panel	60"	TS76030TK	60"	TS76030TKF
78"H Panel	72"	TS77230TK	72"	TS77230TKF

Monolithic Skins

Segmented Skins

54"H Panels

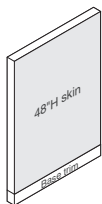

Qty 1 - TS74830TK



Qty 1 - TS74830TKF

54"H Panels



Qty 2 - TS72430TK



Qty 1 - TS72430TK
Qty 1 - TS72430TKF

3. Specify powerkits where you will need power.

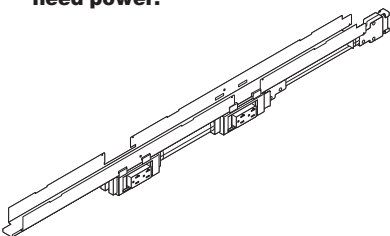

Base Junctions—Thin Trim

Base junctions complete the structure of panel packages and panel buildups. Answer panels always share a junction with adjacent panels. You order the style of junction you need separately. ▶ Specifying thin, page 322.

Thin trim require end-of-run and change-of-height junctions manufactured on or after October 10, 2011.

Corner junction cap aligners ensure correct fit with adjacent panel top caps.

Opening in top of junction allows lay-in cable routing beneath top caps.

Slots in junction accept the panel's horizontal bars every 12", cable trays every 6", and powerkits every 12" vertically.

Slotted channels in junction accommodate worksurface supports and overhead storage components at 1" increments.

Trim is included with L, T, V, and end-of-run junctions to finish exposed surfaces. Trim is available with paint or wood veneer.

Large openings are used to route power or cables through an L, T, X, V, Y, and in-line base junction.

Leveling glides adjust to install panels on uneven floors. Range is 2³/₄".

Inside corner light seals are only needed in 90° applications and are included in the style number when ordering.

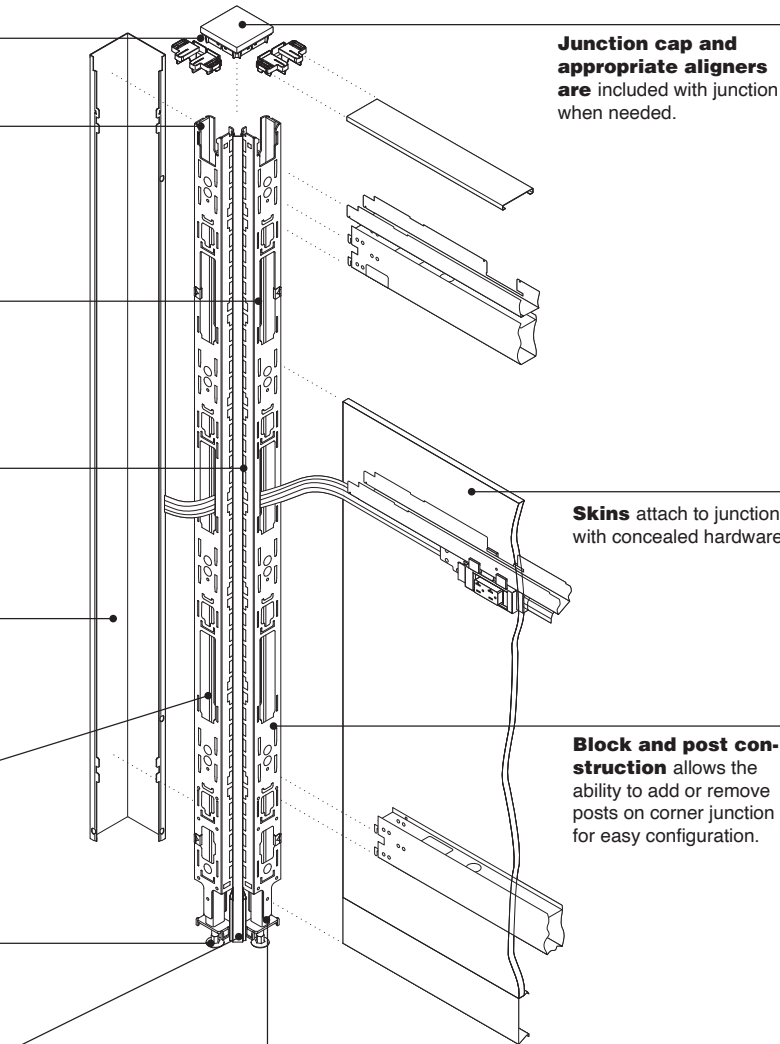

Junction cap and appropriate aligners are included with junction when needed.

Skins attach to junction with concealed hardware.

Block and post construction allows the ability to add or remove posts on corner junction for easy configuration.

Lay-in cable routing is accommodated in base area.

Product Details

Answer is available with three styles of trim - square, oval, and thin. This section covers Thin trims. Base junctions are specified with desired style. Styles can not be mixed between adjacent panels.

▶ For square and oval trims, see page 85.

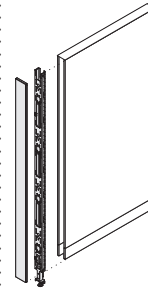

End-of-run base junction includes junction, vertical trim, and trim aligner. Select thin style trim. End-of-run trim adds 1/2" to footprint.

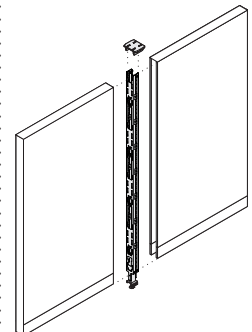

In-line base junction includes junction and plastic top cap aligner. Select thin style trim.

Actual Dimensions

Depth 3"

Height 28⁷/₁₆"*, 34⁵/₈", 40³/₄", 47", 53¹/₈", 65¹/₂", and 77³/₈"

*Note: Wall-start junctions are not available 28⁷/₁₆".

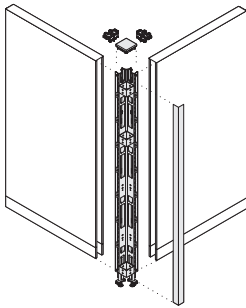

L same height base junction includes junction, inside corner light seal(s), vertical trim, junction cap, and two plastic top cap aligners. Select thin style trim.

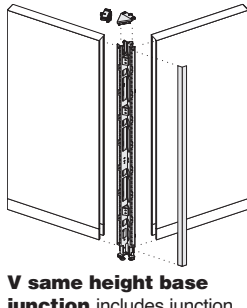

V same height base junction includes junction, vertical trim, junction cap, and plastic top cap aligner. Select thin style trim.

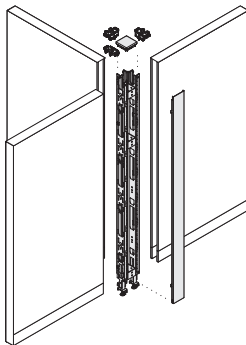

T same height base junction includes junction, inside corner light seal(s), vertical trim, junction cap, and three plastic top cap aligners. Select thin style trim.

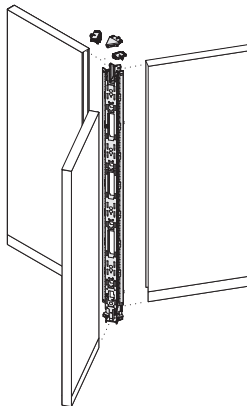

Y same height base junction includes junction, junction cap, and two plastic top cap aligners. Select thin style trim.

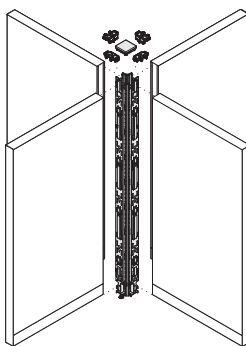

X same height base junction includes junction, inside corner light seal(s), junction cap, and four plastic top cap aligners. Select thin style trim.

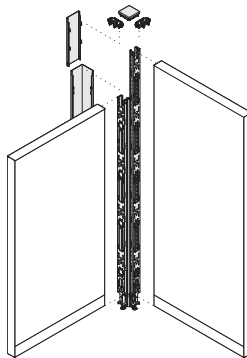

Most change-of-height junction configurations are pre-configured and include junctions and needed trims. Change-of-height junctions that are not pre-configured are available through the build your own process. ▶ See specification information, page 356.

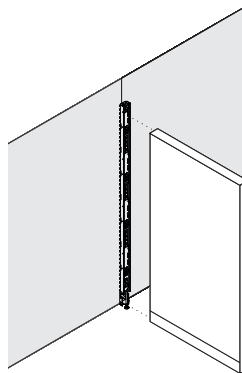

Wall-start junction secures to the stud in a structural wall or drywall fasteners can be used. Vertical trim is not needed. Also used in off-module applications. Wall-start junction adds $\frac{3}{16}$ " dimension to panel run.



An in-line top cap aligner is included with in-line junctions. Select thin style.



Top cap aligners are included with end-of-run, L, T, X, V, and Y junctions.

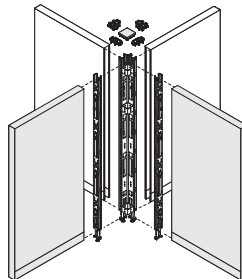

Posts can be added or removed from corner junctions to change from one corner to another.

Connections

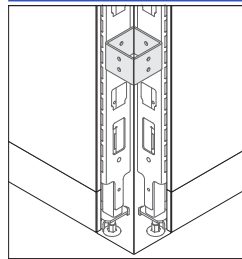

Block and post construction of corner junctions allow junctions to be easily added or removed to configure between L, T, X, V, or Y in an application.

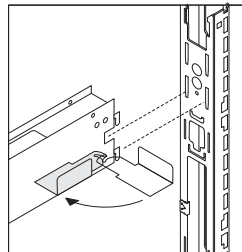

Quick lock on both ends of the panel's horizontal connecting bars engage the junction in a tight structural connection.

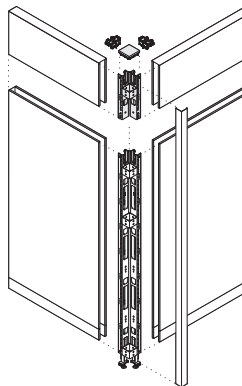

Base junctions can accept a stacking junction. Omit trim option should be selected whenever stacking. Omitting trim removes all vertical trim, junction cap, and aligner(s). Remember to specify vertical trim, junction cap, inside corner light seal(s), and aligners separately. ▶ See page 366.

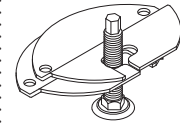

Floor anchor brackets are available to secure junctions to the floor to prevent panel movement. Brackets are intended for use in seismic zones and may require additional code approvals.

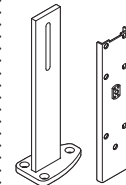

Junction stabilizer bracket can be used to add rigidity to a panel run or when using a Universal sliding door. Bracket must be bolted to a concrete floor. For junctions manufactured before October 10, 2011 use TS7SB. For junctions manufactured on or after October 10, 2011 use TS7SBNJ.

Bracket foot is visible on one side of panel when installed.

Junction stabilizer bracket blocks power routing in the panel base and just above the base areas. The bracket covers the slots on the junction where the powerkit connects in these two zones. It also blocks the ability for a powerkit harness, pass-through powerkit, or modular harness to route in the base area from an adjacent panel.

Junction stabilizer bracket also blocks lay in of cables in base area of panel.

Base Junctions—Thin Trim, continued

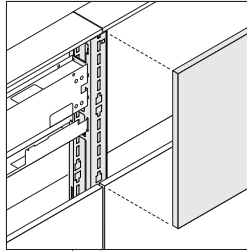

Skins extend onto junction and meet skin of adjacent panel. The slotted channel of the junction is accessible between these two skins.

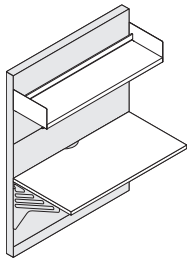

Panels can support work-surfaces, shelves, and bins.

Wiring and Cabling

Lay-in cable routing at top of panel

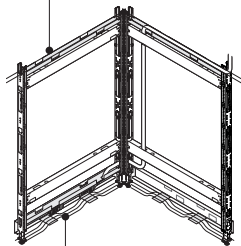

Lay-in cable routing at base of panel

Lay-in cable routing is accommodated in the top of junctions. Lay-in cable and power routing is accommodated in base area.

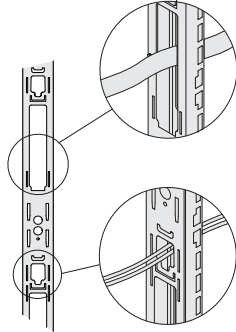

As an alternative to lay-in cable routing, horizontal routing of power and cables can be accommodated through openings in junctions.

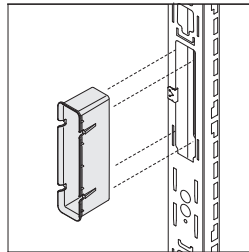

Junction tall sleeves can be ordered to cover the exposed metal edges in the large cable routing opening of junctions. Tall junction sleeve can only be used on junctions manufactured on or after October 10, 2011.

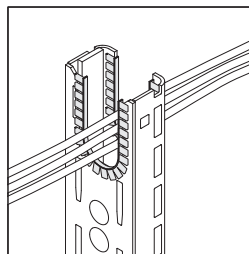

Lay-in junction cable sleeves can be added in the field to cover the exposed metal edges in lay-in cable space.

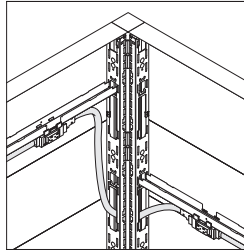

Modular harnesses that are 43" or 80" are available to change the height at which you are routing power kits or to route power from the panel base to different heights.



Carpet gripper glide caps may be added to panel glides to help hold panel in place (used only on junctions manufactured on or after October 10, 2011).

Surface Materials

Base junction

- Black paint
- Tip: Junction is hidden when properly installed.

Junction cap—thin

- Paint
- Wood

Vertical trim—thin

- Paint
- Wood

Painted style numbers

include all painted trim and wood style numbers include all wood trim. It is not recommended to mix painted and wood trim. Wood trim is slightly thicker as a result of adding veneer so some misalignment between elements may result.

Tip: Answer panel wood trims are only available with quarter-cut finishes with the exception of maple finishes. Maple on wood trims is only available with flat-cut finishes. For ordering simplicity, both flat-cut and quarter-cut finishes can be specified on panel trims. However, for all finishes except maple, if a flat-cut finish is selected, the trims will have the coordinating quarter-cut finish. For maple finishes, if quarter-cut is selected, the trims will have the coordinating flat-cut finish. Blending panel trims with other wood products that have flat-cut finishes will be visually acceptable for most applications. If a more exact match is desired for non-maple finishes, please specify quarter-cut finishes for the entire project. If a more exact match is desired for maple finishes, please specify flat-cut finishes for the entire project.

Application Topics

Stacking junctions

can be used with any height base junction.

Stability Guidelines

for application rules.
▶ See page 140

Change-of-Height—Thin Trim

Change-of-height trim

is available for base panels and stacking panels. It is used in in-line and corner applications.

► Specifying thin, page 327.

Note: Change-of-height trims are available in 6"H, 12"H, 18"H, 24"H, 30"H, and 36"H.

Change-of-height (two different panel heights) L, T, X, V, and Y junctions

are supported by style numbers in the following pages. Change-of-height (three different panel heights) T, X, and Y and change-of-height (four different panel heights) X junctions are not supported by style numbers and will need to be specified in the build your own section.

► See page 35 for understanding.

► See page 356 for specifying.

Note: Change-of-height junctions include the necessary change-of-height trim (including junction cap and aligners) for the change-of-height portion. See the following pages for panel height change-of-height applications (two different panel heights) and what is included in each style number.

Change-of-height junctions are shipped assembled. L, V, and some T junctions are handed. A post may have to be moved during installation to achieve the proper "hand".

90° Planning Application

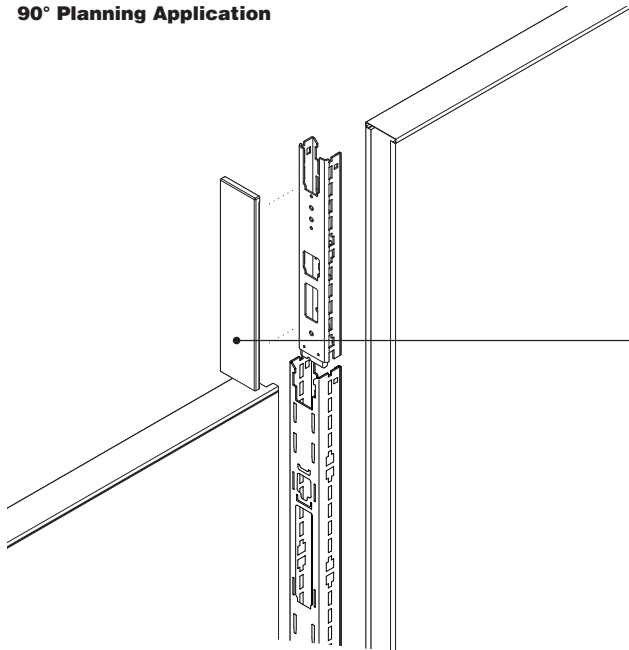

An end-of-run aligner is included with the end-of-run change-of-height trim to provide tight alignment between the top cap and the change-of-height trim. No junction cap is required.

End-of-run change-of-height trim is used at end-of-run or in-line change-of-height. The top of the trim aligns with the top cap on the panel.

90° Planning Application

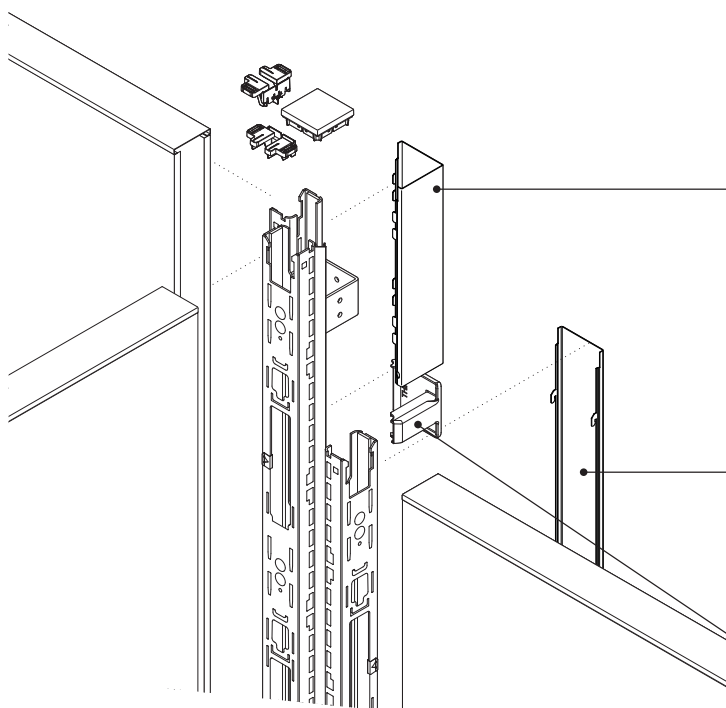

L corner change-of-height trim is used in a T or X change-of-height application when there are two panels at the tallest height located adjacent to each other. No aligners are required to connect the L corner change-of-height trim to the junction cap.

T vertical trim is used to finish trimming out the base of the panel. Base panel trim is included when specifying the change-of-height junction.

An L to T aligner should be specified when an L corner change-of-height trim resides directly above a T trim in a change-of-height application. The L to T aligner creates a tight connection between the two trim pieces.

Actual Dimensions

Depth	3"
Height	6 ³ / ₁₆ ", 12 ⁵ / ₃₂ ", 18 ¹ / ₂ ", 24 ¹ / ₂ ", 30 ⁷ / ₈ ", and 36 ⁷ / ₈ "

An L to T aligner must be specified if an L change-of-height trim is located directly above a T.

No aligners are required to connect a T corner change-of-height trim to the junction cap or top cap.

T corner change-of-height trim is used in T or X change-of-height applications where there are two panels at the same height located in-line with each other.

90° Planning Application

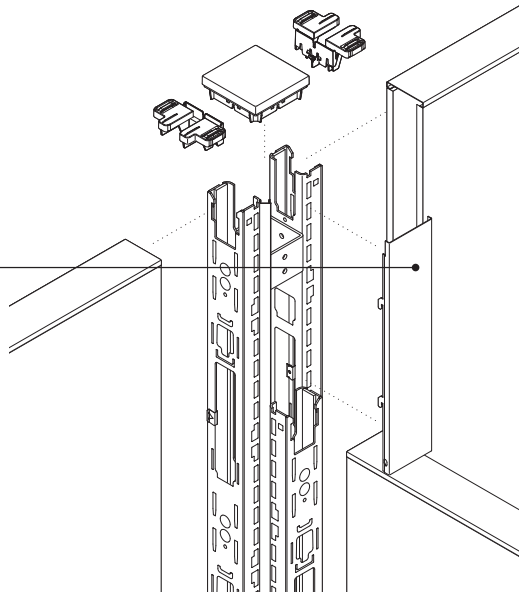

120° Planning Application

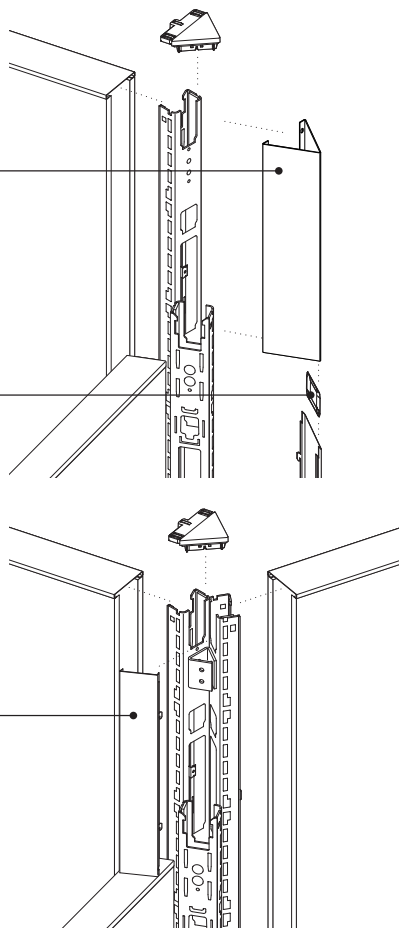

120° corner change-of-height trim is used in a V or Y change-of-height application when there is only one panel at the tallest height. No aligners are required to connect the trim to the junction cap or top cap.

120° to V aligner should be specified when a 120° corner change-of-height trim resides directly above a V trim. The 120° to V aligner creates a tight connection between the two trim pieces.

V corner change-of-height trim is used in a Y change-of-height application when there are two panels at the tallest height. No aligners are required to connect the trim to the junction cap or top cap.

Surface Materials

Change-of-height trim

- Paint
- Wood veneer

Junction cap

- Paint
- Wood veneer

Aligner

- Black plastic only

Application Topics

Change-of-height top cap option must be specified on the lower panel of in-line applications.

Tip: Change-of-height top cap option is only needed when using in-line change-of-height.

Thin trim top caps have a notch in one or both ends to accommodate in-line change-of-height applications.

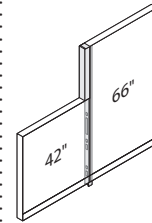

Specify an in-line change-of-height junction to connect panels. In this application the in-line change-of-height junction includes a 42" high in-line base junction with a 24" end-of-run stacker. A horizontal stacking beam is required when using an in-line change-of-height junction to support the stacker.

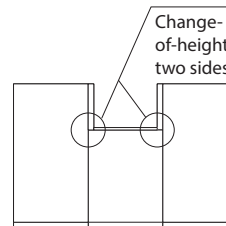
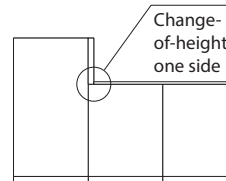

Specify change-of-height top caps at one end unless the panel is adjacent to taller panels on both sides. Then specify a top cap change-of-height on both ends.

Change-of-Height Visual Overview—Thin Trim

Selecting a Junction

To determine the application you need, follow these steps:

1. Find the type of junction you are constructing – L, T, X, V, Y, or in-line. An array of the applications that are supported by style numbers are shown on the following pages. All same height corner junctions are supported by style numbers on pages 323-326. All change-of-height applications (with two different heights) are included on the following pages. If your application is not included (three heights in an T, X, or Y junction or four heights in an X junction) please see *Build Your Own—Thin Trim*, page 40, to build your desired application.
2. It may help if you make a sketch of the junction you are trying to build and then match it with the junction shown on the following pages.
3. Find the type of junction you are looking for in the following pages and see the corresponding specifying page.

Style numbers for junctions are based on the heights of the frames.

Digit in Style Number	Corresponding Frame Height
3	30"
Q	36"
4	42"
5	54"
6	66"
7	78"
8	48"
9	90"

In-Line

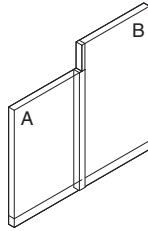

A	B	Style Number
30"	36"	TS73QTCIJ
30"	42"	TS734TCIJ
30"	48"	TS738TCIJ
30"	54"	TS735TCIJ
30"	66"	TS736TCIJ
36"	42"	TS7Q4TCIJ
36"	48"	TS7Q8TCIJ
36"	54"	TS7Q5TCIJ
36"	66"	TS7Q6TCIJ
42"	48"	TS748TCIJ
42"	54"	TS745TCIJ
42"	66"	TS746TCIJ
42"	78"	TS747TCIJ
48"	54"	TS785TCIJ
48"	66"	TS786TCIJ
54"	66"	TS756TCIJ
54"	78"	TS757TCIJ
54"	90"	TS759TCIJ
66"	78"	TS767TCIJ
66"	90"	TS769TCIJ
78"	90"	TS779TCIJ

▶ Page 327 to specify

Junction includes

- In-line base junction
- End-of-run stacking junction
- Stacking fork
- End-of-run change-of-height trim
- Aligner

Tip: Style numbers for wood junctions require a W to be added to the end of the style number.

L Junction



A	B	Style Number
30"	36"	TS73QTCLJ
30"	42"	TS734TCLJ
30"	48"	TS738TCLJ
30"	54"	TS735TCLJ
30"	66"	TS736TCLJ
36"	42"	TS7Q4TCLJ
36"	48"	TS7Q8TCLJ
36"	54"	TS7Q5TCLJ
36"	66"	TS7Q6TCLJ
42"	48"	TS748TCLJ
42"	54"	TS745TCLJ
42"	66"	TS746TCLJ
42"	78"	TS747TCLJ
48"	54"	TS785TCLJ
48"	66"	TS786TCLJ
48"	78"	TS787TCLJ
54"	66"	TS756TCLJ
54"	78"	TS757TCLJ
66"	78"	TS767TCLJ

▶ Page 328 to specify

Junction includes

- L change-of-height junction
- Inside corner light seal
- L vertical trim
- End-of-run change-of-height trim
- Change-of-height junction cap
- Aligners

Tip: Style numbers for wood junctions require a W to be added to the end of the style number.

Tip: When specifying remember this junction is handed and the other hand is not supported by style numbers. While in the field, installers may need to move a post to achieve the desired configuration.

T Junctions

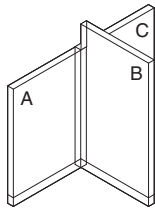

A	B	C	Style Number
30"	36"	30"	TS73Q3TCTJ
30"	42"	30"	TS7343TCTJ
30"	48"	30"	TS7383TCTJ
30"	54"	30"	TS7353TCTJ
30"	66"	30"	TS7363TCTJ
36"	42"	36"	TS7Q4QTCTJ
36"	48"	36"	TS7Q8QTCTJ
36"	54"	36"	TS7Q5QTCTJ
36"	66"	36"	TS7Q6QTCTJ
42"	48"	42"	TS7484TCTJ
42"	54"	42"	TS7454TCTJ
42"	66"	42"	TS7464TCTJ
42"	78"	42"	TS7474TCTJ
48"	54"	48"	TS7858TCTJ
48"	66"	48"	TS7868TCTJ
48"	78"	48"	TS7878TCTJ
54"	66"	54"	TS7565TCTJ
54"	78"	54"	TS7575TCTJ
66"	78"	66"	TS7676TCTJ

► Page 330 to specify

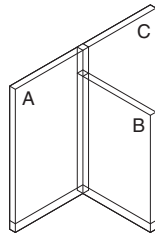

A	B	C	Style Number
36"	30"	36"	TS7Q3QTCTJ
42"	30"	42"	TS7434TCTJ
42"	36"	42"	TS74Q4TCTJ
48"	30"	48"	TS7838TCTJ
48"	36"	48"	TS78Q8TCTJ
48"	42"	48"	TS7848TCTJ
54"	30"	54"	TS7535TCTJ
66"	30"	66"	TS7636TCTJ
54"	36"	54"	TS75Q5TCTJ
54"	42"	54"	TS7545TCTJ
54"	48"	54"	TS7585TCTJ
66"	42"	66"	TS7646TCTJ
78"	42"	78"	TS7747TCTJ
66"	36"	66"	TS76Q6TCTJ
66"	48"	66"	TS7686TCTJ
78"	48"	78"	TS7787TCTJ
66"	54"	66"	TS7656TCTJ
78"	54"	78"	TS7757TCTJ
78"	66"	78"	TS7767TCTJ

► Page 330 to specify

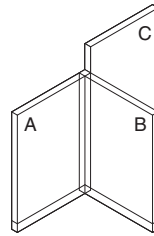

A	B	C	Style Number
30"	30"	36"	TS733QTCTJ
30"	30"	42"	TS7334TCTJ
30"	30"	48"	TS7338TCTJ
30"	30"	54"	TS7335TCTJ
30"	30"	66"	TS7336TCTJ
36"	36"	42"	TS7QQ4TCTJ
36"	36"	48"	TS7QQ8TCTJ
36"	36"	54"	TS7QQ5TCTJ
36"	36"	66"	TS7QQ6TCTJ
42"	42"	48"	TS7448TCTJ
42"	42"	54"	TS7445TCTJ
42"	42"	66"	TS7446TCTJ
42"	42"	78"	TS7447TCTJ
48"	48"	54"	TS7885TCTJ
48"	48"	66"	TS7886TCTJ
48"	48"	78"	TS7887TCTJ
54"	54"	66"	TS7556TCTJ
54"	54"	78"	TS7557TCTJ
66"	66"	78"	TS7667TCTJ

► Page 330 to specify

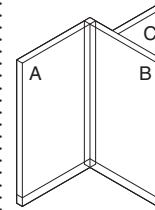

A	B	C	Style Number
36"	36"	30"	TS7Q3TCTJ
42"	42"	30"	TS7443TCTJ
48"	48"	30"	TS7883TCTJ
48"	48"	42"	TS7884TCTJ
54"	54"	30"	TS7553TCTJ
66"	66"	30"	TS7663TCTJ
42"	42"	36"	TS744QTCTJ
48"	48"	36"	TS788QTCTJ
54"	54"	36"	TS755QTCTJ
66"	66"	36"	TS766QTCTJ
54"	54"	42"	TS7554TCTJ
54"	54"	48"	TS7558TCTJ
66"	66"	42"	TS7664TCTJ
78"	78"	42"	TS7774TCTJ
66"	66"	48"	TS7668TCTJ
78"	78"	48"	TS7778TCTJ
66"	66"	54"	TS7665TCTJ
78"	78"	54"	TS7775TCTJ
78"	78"	66"	TS7776TCTJ

► Page 330 to specify

Junction includes

- T change-of-height junction
- Inside corner light seals
- T vertical trim
- End-of-run change-of-height trim
- Change-of-height junction cap
- Aligners

Tip: Style numbers for wood junctions require a W to be added to the end of the style number.

Junction includes

- T change-of-height junction
- Inside corner light seals
- T vertical trim
- T change-of-height trim
- 90° junction cap
- Aligner

Tip: Style numbers for wood junctions require a W to be added to the end of the style number.

Junction includes

- T change-of-height junction
- Inside corner light seals
- T vertical trim
- End-of-run change-of-height trim
- Change-of-height junction cap
- Aligners

Tip: Style numbers for wood junctions require a W to be added to the end of the style number.

Tip: When specifying remember this junction is handed and the other hand is not supported by style numbers. While in the field, installers may need to move a post to achieve the desired configuration.

Junction includes

- T change-of-height junction
- Inside corner light seals
- T vertical trim
- L change-of-height trim
- 90° junction cap
- Aligner

Tip: Style numbers for wood junctions require a W to be added to the end of the style number.

Tip: When specifying remember this junction is handed and the other hand is not supported by style numbers. While in the field, installers may need to move a post to achieve the desired configuration.

Change-of-Height Visual Overview—Thin Trim, continued

X Junctions

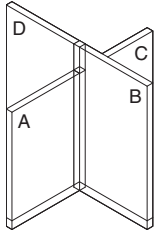

A	B	C	D	Style Number
30"	36"	30"	36"	TS73Q3QTCXJ
30"	42"	30"	42"	TS73434TCXJ
30"	48"	30"	48"	TS73838TCXJ
30"	54"	30"	54"	TS73535TCXJ
30"	66"	30"	66"	TS73636TCXJ
36"	42"	36"	42"	TS7Q4Q4TCXJ
36"	48"	36"	48"	TS7Q8Q8TCXJ
36"	54"	36"	54"	TS7Q5Q5TCXJ
36"	66"	36"	66"	TS7Q6Q6TCXJ
42"	48"	42"	48"	TS74848TCXJ
42"	54"	42"	54"	TS74545TCXJ
42"	66"	42"	66"	TS74646TCXJ
42"	78"	42"	78"	TS74747TCXJ
48"	54"	48"	54"	TS78585TCXJ
48"	66"	48"	66"	TS78686TCXJ
48"	78"	48"	78"	TS78787TCXJ
54"	66"	54"	66"	TS75656TCXJ
54"	78"	54"	78"	TS75757TCXJ
66"	78"	66"	78"	TS76767TCXJ

▶ Page 334 to specify

Junction includes

- X change-of-height junction
- Inside corner light seals
- Two T change-of-height trims
- 90° junction cap
- Aligner

*Tip: Style numbers for wood junctions require a **W** to be added to the end of the style number.*

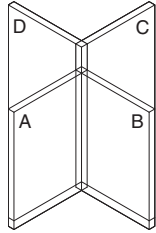

A	B	C	D	Style Number
30"	30"	36"	36"	TS733QQTCXJ
30"	30"	42"	42"	TS73344TCXJ
30"	30"	48"	48"	TS73388TCXJ
30"	30"	54"	54"	TS73355TCXJ
30"	30"	66"	66"	TS73366TCXJ
36"	36"	42"	42"	TS7QQ44TCXJ
36"	36"	48"	48"	TS7QQ88TCXJ
36"	36"	54"	54"	TS7QQ55TCXJ
36"	36"	66"	66"	TS7QQ66TCXJ
42"	42"	48"	48"	TS74488TCXJ
42"	42"	54"	54"	TS74455TCXJ
42"	42"	66"	66"	TS74466TCXJ
42"	42"	78"	78"	TS74477TCXJ
48"	48"	54"	54"	TS78855TCXJ
48"	48"	66"	66"	TS78866TCXJ
48"	48"	78"	78"	TS78877TCXJ
54"	54"	66"	66"	TS75566TCXJ
54"	54"	78"	78"	TS75577TCXJ
66"	66"	78"	78"	TS76677TCXJ

▶ Page 334 to specify

Junction includes

- X change-of-height junction
- Inside corner light seals
- L change-of-height trim
- 90° junction cap
- Aligner

*Tip: Style numbers for wood junctions require a **W** to be added to the end of the style number.*

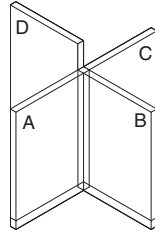

A	B	C	D	Style Number
30"	30"	30"	36"	TS7333QTCXJ
30"	30"	30"	42"	TS73334TCXJ
30"	30"	30"	48"	TS73338TCXJ
30"	30"	30"	54"	TS73335TCXJ
30"	30"	30"	66"	TS73336TCXJ
36"	36"	36"	42"	TS7QQQ4TCXJ
36"	36"	36"	48"	TS7QQQ8TCXJ
36"	36"	36"	54"	TS7QQQ5TCXJ
36"	36"	36"	66"	TS7QQQ6TCXJ
42"	42"	42"	48"	TS74448TCXJ
42"	42"	42"	54"	TS74445TCXJ
42"	42"	42"	66"	TS74446TCXJ
42"	42"	42"	78"	TS74447TCXJ
48"	48"	48"	54"	TS78885TCXJ
48"	48"	48"	66"	TS78886TCXJ
48"	48"	48"	78"	TS78887TCXJ
54"	54"	54"	66"	TS75556TCXJ
54"	54"	54"	78"	TS75557TCXJ
66"	66"	66"	78"	TS76667TCXJ

▶ Page 334 to specify

Junction includes

- X change-of-height junction
- Inside corner light seals
- End-of-run change-of-height trim
- Change-of-height junction cap
- Aligners

*Tip: Style numbers for wood junctions require a **W** to be added to the end of the style number.*

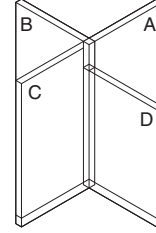

A	B	C	D	Style Number
36"	36"	36"	30"	TS7QQQ3TCXJ
42"	42"	42"	30"	TS74443TCXJ
48"	48"	48"	30"	TS78883TCXJ
54"	54"	54"	30"	TS75553TCXJ
42"	42"	42"	36"	TS7444QTCXJ
48"	48"	48"	36"	TS7888QTCXJ
54"	54"	54"	36"	TS7555QTCXJ
66"	66"	66"	36"	TS7666QTCXJ
54"	54"	54"	42"	TS75554TCXJ
48"	48"	48"	42"	TS78884TCXJ
66"	66"	66"	30"	TS76663TCXJ
66"	66"	66"	42"	TS76664TCXJ
66"	66"	66"	48"	TS76668TCXJ
54"	54"	54"	48"	TS75558TCXJ
66"	66"	66"	54"	TS76665TCXJ
78"	78"	78"	42"	TS77774TCXJ
78"	78"	78"	48"	TS77778TCXJ
78"	78"	78"	54"	TS77775TCXJ
78"	78"	78"	66"	TS77776TCXJ

▶ Page 334 to specify

Junction includes

- X change-of-height junction
- Inside corner light seals
- T change-of-height trim
- 90° junction cap
- Aligners

*Tip: Style numbers for wood junctions require a **W** to be added to the end of the style number.*

V Junctions

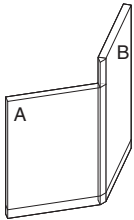

A	B	Style Number
30"	36"	TS73QTCVJ
30"	42"	TS734TCVJ
30"	48"	TS738TCVJ
30"	54"	TS735TCVJ
30"	66"	TS736TCVJ
36"	42"	TS7Q4TCVJ
36"	48"	TS7Q8TCVJ
36"	54"	TS7Q5TCVJ
36"	66"	TS7Q6TCVJ
42"	48"	TS748TCVJ
42"	54"	TS745TCVJ
42"	66"	TS746TCVJ
42"	78"	TS747TCVJ
48"	54"	TS785TCVJ
48"	66"	TS786TCVJ
48"	78"	TS787TCVJ
54"	66"	TS756TCVJ
54"	78"	TS757TCVJ
66"	78"	TS767TCVJ

▶ Page 338 to specify

Junction includes

- V change-of-height junction
- V vertical trim
- 120° change-of-height trim
- 120° junction cap
- Aligner

Tip: Style numbers for wood junctions require a W to be added to the end of the style number.

Tip: When specifying remember this junction is handed and the other hand is not supported by style numbers. While in the field, installers may need to move a post to achieve the desired configuration.

Y Junctions

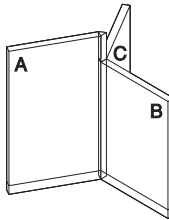

A	B	C	Style Number
36"	30"	30"	TS7Q33TCYJ
42"	30"	30"	TS7433TCYJ
48"	30"	30"	TS7833TCYJ
48"	42"	42"	TS7844TCYJ
54"	30"	30"	TS7533TCYJ
66"	30"	30"	TS7633TCYJ
42"	36"	36"	TS74QQTCYJ
48"	36"	36"	TS78QQTCYJ
54"	36"	36"	TS75QQTCYJ
66"	36"	36"	TS76QQTCYJ
54"	42"	42"	TS7544TCYJ
54"	48"	48"	TS7588TCYJ
66"	42"	42"	TS7644TCYJ
78"	42"	42"	TS7744TCYJ
66"	48"	48"	TS7688TCYJ
78"	48"	48"	TS7788TCYJ
66"	54"	54"	TS7655TCYJ
78"	54"	54"	TS7755TCYJ
78"	66"	66"	TS7766TCYJ

▶ Page 340 to specify

Junction includes

- Y change-of-height junction
- 120° change-of-height trim
- 120° junction cap

Tip: Style numbers for wood junctions require a W to be added to the end of the style number.

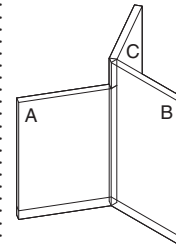

A	B	C	Style Number
30"	36"	36"	TS73QQTCYJ
30"	42"	42"	TS7344TCYJ
30"	48"	48"	TS7388TCYJ
30"	54"	54"	TS7355TCYJ
30"	66"	66"	TS7366TCYJ
36"	42"	42"	TS7Q44TCYJ
36"	48"	48"	TS7Q88TCYJ
36"	54"	54"	TS7Q55TCYJ
36"	66"	66"	TS7Q66TCYJ
42"	48"	48"	TS7488TCYJ
42"	54"	54"	TS7455TCYJ
42"	66"	66"	TS7466TCYJ
42"	78"	78"	TS7477TCYJ
48"	54"	54"	TS7855TCYJ
48"	66"	66"	TS7866TCYJ
48"	78"	78"	TS7877TCYJ
54"	66"	66"	TS7566TCYJ
54"	78"	78"	TS7577TCYJ
66"	78"	78"	TS7677TCYJ

▶ Page 340 to specify

Junction includes

- Y change-of-height junction
- V change-of-height trim
- 120° junction cap
- Aligner

Tip: Style numbers for wood junctions require a W to be added to the end of the style number.

Off-Module Panel Connector—Thin Trim

Off-module panel connectors allow a fin wall to be attached off-module to a spine wall in 1" increments.

► Specifying, page 344

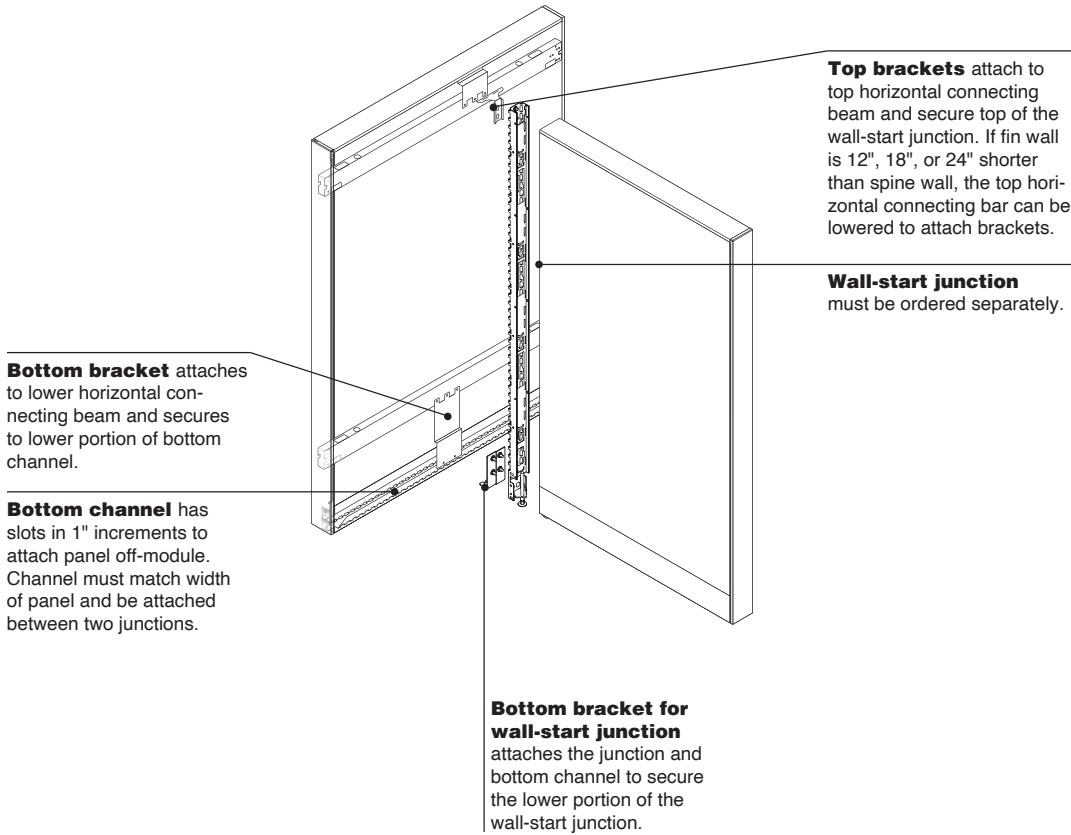

Bottom bracket attaches to lower horizontal connecting beam and secures to lower portion of bottom channel.

Bottom channel has slots in 1" increments to attach panel off-module. Channel must match width of panel and be attached between two junctions.

Bottom bracket for wall-start junction attaches the junction and bottom channel to secure the lower portion of the wall-start junction.

Top brackets attach to top horizontal connecting beam and secure top of the wall-start junction. If fin wall is 12", 18", or 24" shorter than spine wall, the top horizontal connecting bar can be lowered to attach brackets.

Wall-start junction must be ordered separately.

Product Details

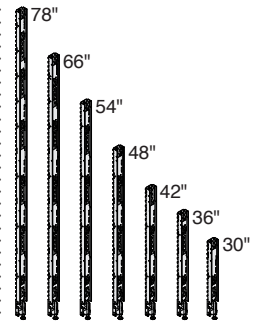

Wall-start junctions connect to the off-module panel connectors to start a panel run off from the spine. Available in 30"H, 36"H, 42"H, 48"H, 54"H, 66"H, and 78"H. Wall-start junction must match the height of the fin wall. Wall-start junctions are ordered separately.

Connections

Off-module fin wall must always be the same height or shorter than the spine wall.

24" maximum

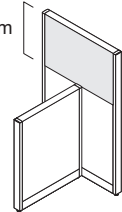

When fin wall is more than 24" shorter than the spine wall an additional horizontal beam must be added to the spine wall at the same height as the fin wall. Order a stacking horizontal frame kit.

Spine wall skins must be segmented with a seam matching the height of the shorter fin wall. This allows access to the top bracket and the spine wall horizontal beam.

Actual Dimensions

Width 22¹/₂", 34¹/₂", 40¹/₂", 46¹/₂", 58¹/₂", and 70¹/₂"

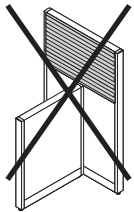

Slatwall skins cannot be placed on the spine panel when an off-module fin panel is positioned below it.

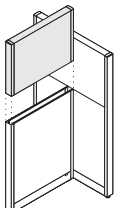

When stacking on the fin panel, the spine wall skins must be segmented with a seam matching the height of the fin base panel.

When stacking wall-start junctions in an off-module application, the off-module panel connector connects to the base wall-start junction.

Two off-module panels can be connected back to back at the same location.

Spine: 36"H or 48" base junctions with stackers

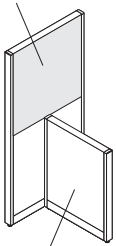

36"H or 48"H Fin

For off-module fin walls 36"H or 48"H, base junctions must match the height of fin wall base junctions. Taller spine wall heights can be achieved by stacking.

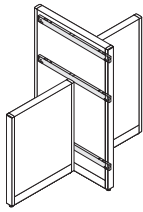

When connecting two off-module fins at different heights on either side of the spine panel, an additional horizontal beam must be ordered and installed at the same height of the shorter fin panel.

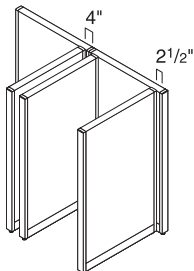

An off-module fin wall cannot connect flush to the end of a panel in the spine wall. The closest connection point will leave a 2 1/2" tail on the spine including the end-of-run trim.

An off-module fin wall cannot attach at a junction in the spine wall. There is a 2" area of dead space on either side of the junction rendering a total of 4" dead space.

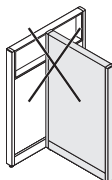

An off-module fin wall cannot be installed over a window that is located at the top of a spine panel.

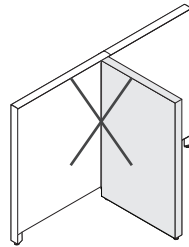

An off-module connector cannot be used on a spine wall with open base trim.

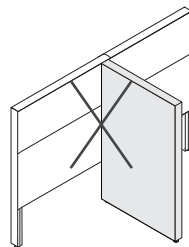

An off-module connector cannot be used on a spine wall with big open base.

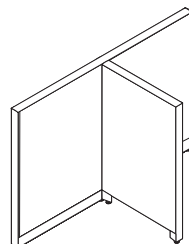

A fin panel connected off-module can have open base trim.

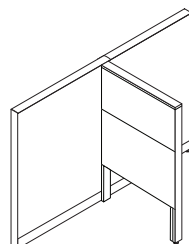

A fin panel connected off-module can have big open base trim.

Wiring & Cabling

Wiring and cabling components cannot be routed internally from a spine wall to an off-module fin wall without cutting openings in the spine wall skin. *Tip: It is recommended that you route wiring and cabling through the spine wall.*

Modular power components should be used to bring power from the spine wall to the workstation.

Surface Materials

Off-module bracket

- Black paint

Tip: Bracket is hidden when properly installed.

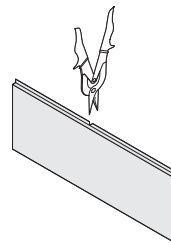

Off-module installation requires field modification of the light seal on the top skin. Surface covering is not affected.

Application Topics

Stability Guidelines for Application Rules

▶ Page 140

Stacking junctions can be used with any height base junction.

Bins, shelves, and workspaces cannot be attached off-module.

Off-module panel connector works with Thin trims. Thin style trims do not require a top cap filler.

When using a wall-start junction manufactured before October 10, 2011 with an off module panel connector manufactured on or after October 10, 2011 the "old" bottom bracket must be used. It can be ordered from Service Parts, part number TSS00938MP. If using an old off-module panel connector manufactured before October 10, 2011 with a wall-start junction manufactured on or after October 10, 2011 the bottom bracket included with the off module panel connector should be used.

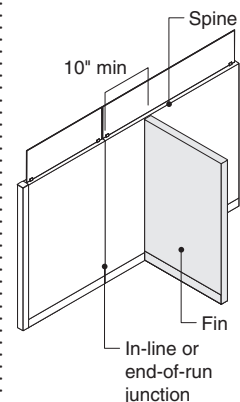

When using frameless glass with clip attachment on a spine panel, with a same height off-module panel connection, the off-module cannot connect within 10" of an end-of-run or in-line junction connection.

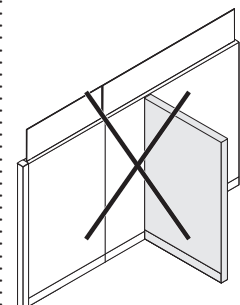

Recessed frameless glass cannot be used on a spine panel hosting the same height off-module connection. The off-module fin panel can use recessed frameless glass, but must have the wallstart option specified.

Stacking Junctions—Thin Trim

Stacking junctions allow you to adjust the panel heights within a workstation.
 ▶ Specifying thin, page 345

Stacking junctions are available for in-line, L, T, X, V, Y, end-of-run, and wall-start configurations.

Stacking horizontal frame package, specified separately, must be used with stacking junctions. Each package includes one horizontal connecting bar.

When stacking, omit base junction trim and specify full height (base height plus stacking height) vertical trim, junction cap, and aligners separately.

Fork connectors are included with stacking junction for proper connection to the base panel.

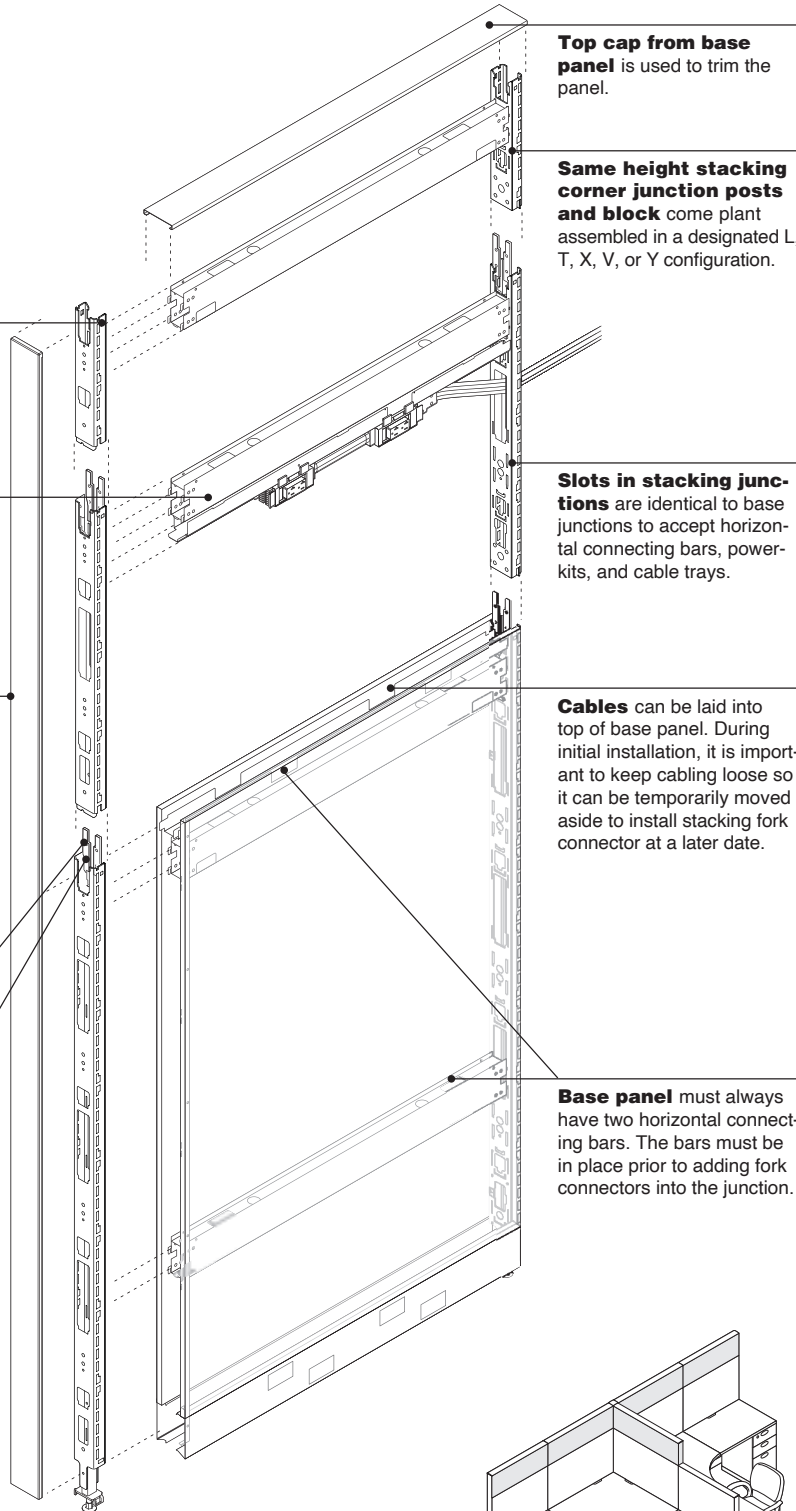
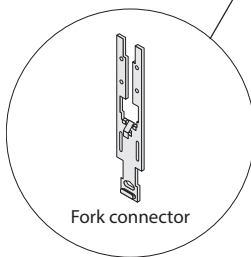

Top cap from base panel is used to trim the panel.

Same height stacking corner junction posts and block come plant assembled in a designated L, T, X, V, or Y configuration.

Slots in stacking junctions are identical to base junctions to accept horizontal connecting bars, power-kits, and cable trays.

Cables can be laid into top of base panel. During initial installation, it is important to keep cabling loose so it can be temporarily moved aside to install stacking fork connector at a later date.

Base panel must always have two horizontal connecting bars. The bars must be in place prior to adding fork connectors into the junction.

Product Details

All existing base panels can accept a stacking junction.

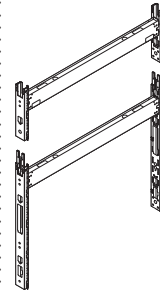

Stacking junctions do not include any trim. The omit trim option should be specified on base junctions when stacking. All vertical trim, junction caps, and aligners are specified separately when stacking on base junction.

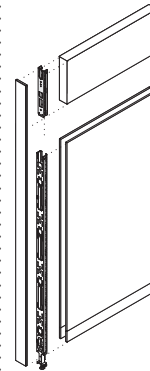

End-of-run stacking junction includes junction and fork connector. Full height trim must be specified separately. End-of-run trim adds 1/2" to footprint.

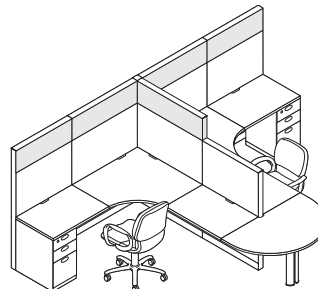

Actual Dimensions

- Depth** 3"
- Height** 6³/₁₆", 12³/₈", 18¹/₂", and 24³/₄"

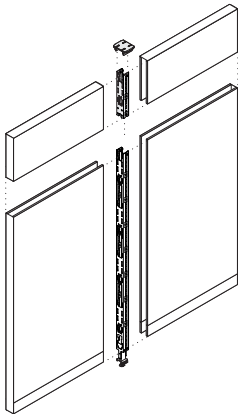

In-line stacking junction includes junction and fork connectors.

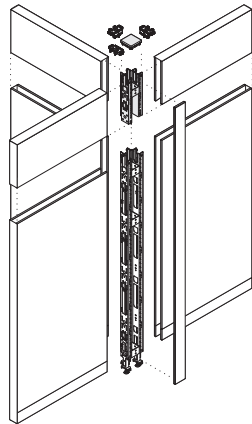

T-stacking junction includes junction and fork connectors. Full height trim, junction cap and aligner(s) must be specified separately.

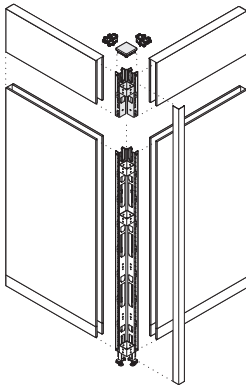

L-stacking junction includes junction and fork connectors. Full height trim, junction cap and aligner(s) must be specified separately.

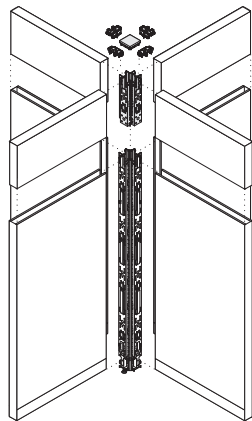

X-stacking junction includes junction and fork connectors.

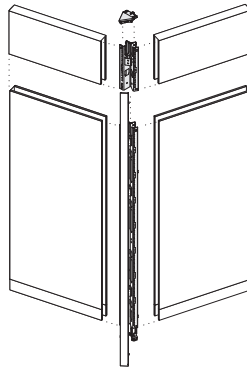

V-stacking junction includes junction and fork connectors. Full height trim, junction cap and aligner(s) must be specified separately.

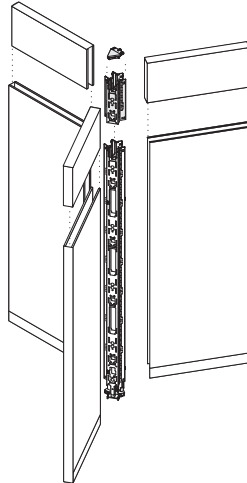

Y-stacking junction includes junction and fork connectors.

Full height vertical trim is available in the specifying section in 30", 36", 42", 48", 54", 60", 66", 72", 78", 84", and 90".
▶ Specifying thin, page 350.

Standard skins, cable trays, and powerkits are used in stackable solutions. To maximize the benefits of stackability, consider matching the skin height to the stacking junction height.

Connections

Skins on base panel do not need to be removed to install a stacking junction in most cases.

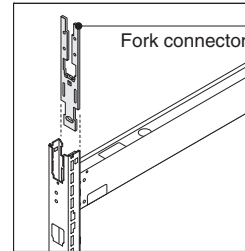

Fork connector is included with stacking junction for proper connection to the base panel. Two fork connectors are included with in-line, L, and V stacking junctions, three are included with T and Y stacking junctions, and four are included with X stacking junctions. One fork connector is included with each wall-start stacking junction and end-of-run.

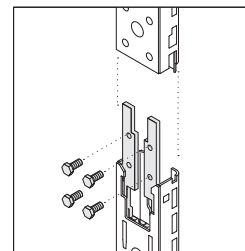

Fork connectors secure into the base junction. Stacking junction is bolted to fork connectors.

Wiring & Cabling

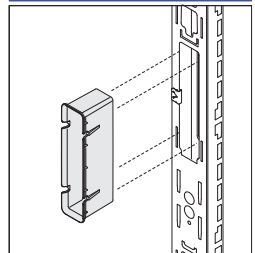

Junction tall sleeves can be ordered to cover the exposed metal edges in the large cable routing opening of the junctions manufactured on or after October 10, 2011.

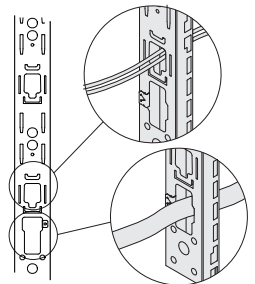

Horizontal routing of power and cables can be accommodated through openings in stacking junctions.

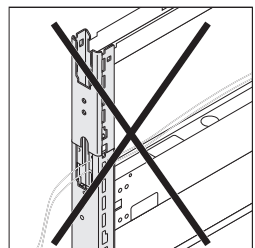

Power and data cables cannot route through the joint, the top of base panel and bottom of 6"H stacker interfere.

Powerkit installation for stacking components is the same process as for installation in base panels.

Stacking Junctions—Thin Trim, continued

Surface Materials

Stacking junction

- Black paint
- Tip: Junction is hidden when properly installed.*

Application Topics

Stacking stability

guidelines provide detailed information on applications. ▶ Page 140

Maximum height that can be stacked on a base panel is 36", consisting of one 24"H and one 12"H, or two 18"H stacking junction.

Maximum height that an Answer panel configuration can reach is 90".

Maximum number of stacking junctions that can be added to a base panel is two.

Any height base panel can be used with stacking junctions.

Bins and shelves can hang from the first stacked tier only.

When using 6"H stacking junctions, a stacking horizontal beam is not needed.

Hanging components are not allowed on the 6"H stacking junctions.

Frameless glass, transaction tops, Universal and Sarto top cap screens, and top cap mounted storage cannot be mounted on a 6"H stacking junction.

12"H slatwall skin cannot be placed on the top of the 6"H stacking junction.

6"H stacking junction can be placed only on base junction. It cannot be used on top of another stacking junction.

Glass windows cannot be placed in the top position of a panel segment that has a 6"H stacker.

Junction Posts

► Specifying, page 356

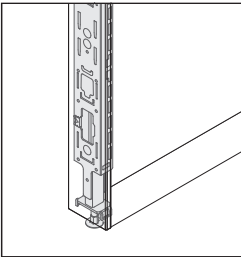
Product Details

Junction posts are available in 30"H, 36"H, 42"H, 48"H, 54"H, 66"H, and 78"H and can be ordered separately for use in building change-of-height junctions that are not supported by style numbers.

Junction posts do not come with trim. All trim must be specified separately.

Junction posts can be fastened to 90° corner or 120° corner junction blocks. Posts can be easily added or removed from the junction blocks to reconfigure the application.

Fasteners are included with the junction blocks. For additional fasteners order part number T521882MP (quantity 50).

Surface Materials

- Black paint only

Junction Blocks

► Specifying, page 357

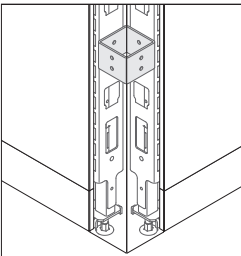
Product Details

90° corner and 120° corner junction blocks can be ordered separately for use in building change-of-height junctions that are not supported by style numbers.

90° corner and 120° corner junction blocks are available in packages of three, four, or five.

Four fasteners are included with each junction block.

Junction post can be easily added or removed from junction blocks to reconfigure the application.

Surface Materials

- Black paint only

Inside Corner Light Seal

► Specifying, page 357

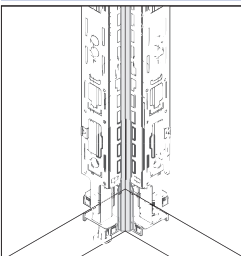
Product Details

Inside corner light seals are available in 54"H, 66"H, and 78"H and need to be specified in 90° corner junction applications (they are not required in 120° corner applications).

Inside corner light seals are available in packages of four.

Inside corner light seals should be specified to the panel in a shorter 90° change-of-height corner.

Inside corner light seals can be field cut to accommodate shorter post heights.

Surface Materials

- Black paint only

Build Your Own Elements—Thin Trim, continued

Junction Caps

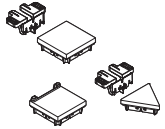

► Specifying, page 358

Product Details

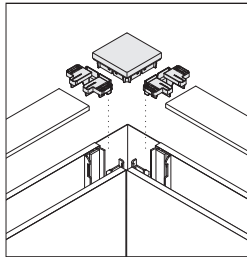

90° junction caps, 90° change-of-height junction caps, and 120° junction caps can be ordered separately for use in building change-of-height junctions that are not supported by style numbers.

Junction cap corner aligners (TS7CJCA10) must be ordered separately (package of 10).

90° junction caps can be used in L, T, or X applications and can be converted between applications by adding or removing a junction cap corner aligner.

120° junction caps can be used in V or Y applications and can be converted between applications by adding or removing a junction cap corner aligner.

90° change-of-height junction caps are used in some L, T, and X change-of-height junctions.

Surface Materials

- Plastic
- Wood veneer

Junction Cap Aligner



► Specifying, page 359

Product Details

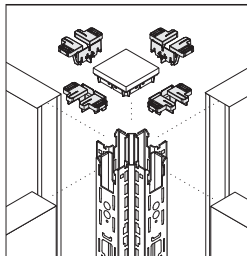

Junction cap aligners need to be ordered for all corner junctions that are not supported by style numbers.

Junction cap aligners are available in packages of 10.

Junction cap aligners need to be ordered for use with 90° change-of-height caps.

Surface Materials

- Black plastic only

Vertical Trim Aligners

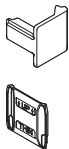

► Specifying, page 359

Product Details

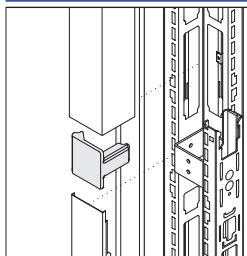

L to T aligners and 120° to V aligners can be ordered separately for use in building change-of-height junctions that are not supported by style numbers.

Vertical trim aligners are available in packages of four.

L to T aligners are used in change-of-height applications to connect an L change-of-height trim to a T vertical trim.

120° to V aligners are used in change-of-height applications to connect a 120° change-of-height trim to a V vertical trim.

Surface Materials

- Black plastic only

End-of-Run Vertical Trim—Thin Trim



► Specifying, page 350

Product Details

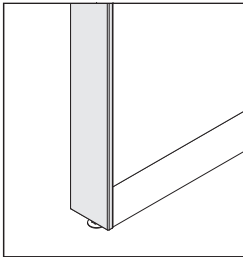

Thin end-of-run vertical trim should be specified for the full height of the panel (base height plus stacking height, if stacking).

Thin end-of-run applications do not require a junction cap as the end-of-run trim connects with the panel top cap.

Vertical trim aligners to connect the end-of-run vertical trim to the top cap are included with the end-of-run vertical trim.

Thin end-of-run vertical trim can only be applied to end-of-run junctions manufactured on or after October 10, 2011.

Surface Materials

- Paint
 - Wood
- Tip: Composite veneers are not available on Answer trims.*

Actual Dimensions

Height: 28¹⁵/₁₆" , 34³/₄" , 41¹/₄" , 47⁷/₁₆" , 53⁵/₈" , 59¹³/₁₆" , 66" , 72³/₁₆" , 78³/₈" , 84⁹/₁₆" , and 90¹¹/₁₆"

L Vertical Trim—Thin Trim



► Specifying, page 351

Product Details

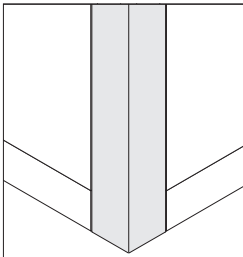

L vertical trim height should be determined by using the build your own change-of-height junctions or build your own stacking junction sections of this specification guide.

90° junction caps and junction cap aligners are not included with L vertical trim and must be ordered separately.

Surface Materials

- Paint
 - Wood
- Tip: Composite veneers are not available on Answer trims.*

Actual Dimensions

Height: 28¹⁵/₁₆" , 34³/₄" , 41¹/₄" , 47⁷/₁₆" , 53⁵/₈" , 59¹³/₁₆" , 66" , 72³/₁₆" , 78³/₈" , 84⁹/₁₆" , and 90¹¹/₁₆"

T Vertical Trim—Thin Trim



► Specifying, page 351

Product Details

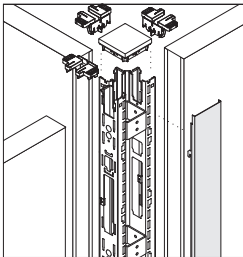

T vertical trim height should be determined by using the build your own change-of-height junctions or build your own stacking junction sections of this specification guide.

90° junction caps and junction cap aligners are not included with T vertical trim and must be ordered separately.

An L to T aligner needs to be specified in applications connecting a thin L change-of-height trim to a T vertical trim.
► See page 359.

Surface Materials

- Paint
 - Wood
- Tip: Composite veneers are not available on Answer trims.*

Actual Dimensions

Height: 28¹⁵/₁₆" , 34³/₄" , 41¹/₄" , 47⁷/₁₆" , 53⁵/₈" , 59¹³/₁₆" , 66" , 72³/₁₆" , 78³/₈" , 84⁹/₁₆" , and 90¹¹/₁₆"

Build Your Own Elements—Thin Trim, continued

V Vertical Trim—Thin Trim



► Specifying, page 352

Product Details

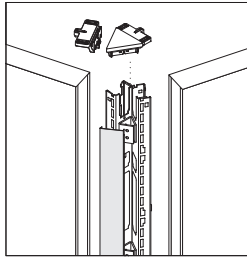

V vertical trim height should be determined by using the build your own change-of-height junctions or build your own stacking junction sections of this specification guide.

120° junction caps and junction cap aligners

are not included with V vertical trim and must be ordered separately.

A 120° to V aligner needs to be specified separately in applications connecting a thin 120° change-of-height trim to a V vertical trim.

► See page 359.

Surface Materials

- Paint
 - Wood
- Tip: Composite veneers are not available on Answer trims.*

Actual Dimensions

Height: 28¹⁵/₁₆" , 34³/₄" , 41¹/₄" , 47⁷/₁₆" , 53⁵/₈" , 59¹³/₁₆" , 66" , 72³/₁₆" , 78³/₈" , 84⁹/₁₆" , and 90¹/₁₆"

End-of-Run/In-Line Change-of-Height Trim—Thin Trim



► Specifying, page 353

Product Details

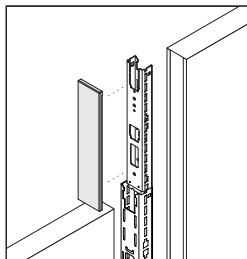

End-of-run/in-line change-of-height should be determined by using the build your own change-of-height junctions or build your own stacking junction sections of this specification guide.

Vertical trim aligners to connect the change-of-height end-of-run/in-line vertical trim to the top cap are included with the end-of-run vertical trim.

Thin end-of-run/in-line change-of-height trim can only be applied to junctions manufactured on or after October 10, 2011.

Surface Materials

- Paint
 - Wood
- Tip: Composite veneers are not available on Answer trims.*

Actual Dimensions

Height: 6³/₁₆" , 12⁵/₁₆" , 18¹/₂" , 24¹/₁₆" , 30⁷/₈" , 35³/₃₂" , and 37¹/₁₆"

L Corner Change-of-Height—Thin Trim



► Specifying, page 354

Product Details

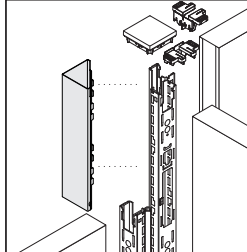

L corner change-of-height trim height should be determined by using the build your own change-of-height junctions or build your own stacking junction sections of this specification guide.

An L to T aligner needs to be specified in applications connecting a thin L change-of-height trim to a T vertical trim.

► See page 359.

Thin L change-of-height trim can only be applied to junctions manufactured on or after October 10, 2011.

Surface Materials

- Paint
 - Wood
- Tip: Composite veneers are not available on Answer trims.*

Actual Dimensions

Height: 6³/₁₆" , 12⁵/₁₆" , 18¹/₂" , 24¹/₁₆" , 30⁷/₈" , 35³/₃₂" , and 37¹/₁₆"

T Corner Change-of-Height—Thin Trim



► Specifying, page 354

Product Details

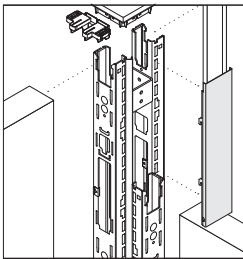

T corner change-of-height trim height should be determined by using the build your own change-of-height junctions or build your own stacking junction sections of this specification guide.

An L to T aligner needs to be specified in applications connecting a thin L change-of-height trim to a T vertical trim.
► See page 359.

Thin T change-of-height trim can only be applied to junctions manufactured on or after October 10, 2011.

Surface Materials

- Paint
 - Wood
- Tip: Composite veneers are not available on Answer trims.*

Actual Dimensions

Height: 6³/₁₆" , 12⁵/₁₆" , 18¹/₂" , 24¹¹/₁₆" , 30⁷/₈" , 35³/₃₂" , and 37¹/₁₆"

120° Corner Change-of-Height—Thin Trim



► Specifying, page 355

Product Details

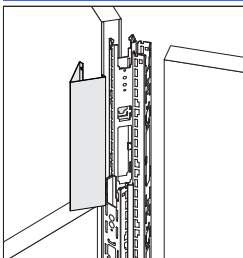

120° corner change-of-height trim height should be determined by using the build your own change-of-height junctions or build your own stacking junction sections of this specification guide.

A 120° to V aligner needs to be specified separately in applications connecting a thin 120° change-of-height trim to a V vertical trim.
► See page 359.

Thin 120° change-of-height trim can only be applied to junctions manufactured on or after October 10, 2011.

Surface Materials

- Paint
 - Wood
- Tip: Composite veneers are not available on Answer trims.*

Actual Dimensions

Height: 6³/₁₆" , 12⁵/₁₆" , 18¹/₂" , 24¹¹/₁₆" , 30⁷/₈" , and 37¹/₁₆"

V Corner Change-of-Height—Thin Trim



► Specifying, page 355

Product Details

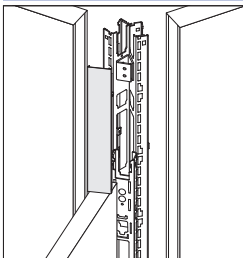

V corner change-of-height trim height should be determined by using the build your own change-of-height junctions or build your own stacking junction sections of this specification guide.

A 120° to V aligner needs to be specified separately in applications connecting a thin 120° change-of-height trim to a V vertical trim.
► See page 359.

V corner change-of-height trim can only be applied to junctions manufactured on or after October 10, 2011.

Surface Materials

- Paint
 - Wood
- Tip: Composite veneers are not available on Answer trims.*

Actual Dimensions

Height: 6³/₁₆" , 12⁵/₁₆" , 18¹/₂" , 24¹¹/₁₆" , 30⁷/₈" , and 37¹/₁₆"

Build Your Own Change-of-Height—Thin Trim

Usage Rules

Follow these for all three height T, X, or Y applications and for all four height X applications. The change-of-height overview pages illustrate and provide a style number for all other standard combinations.

Example

Four change-of-height X application.

Post heights:

- 66"
- 54"
- 42"
- 30"

Trim:

- 12" change-of-height end-of-run
- Change-of-height corner junction cap
- 12" L change-of-height trim
- L to T aligner
- 12" T change-of-height trim
- Aligners

The specification guide supports specific style numbers for all L, T, X, V, and Y change-of-height applications with two heights (see page 328). If the change-of-height application has three or more heights, you must follow the directions on the following pages to properly specify your desired application.

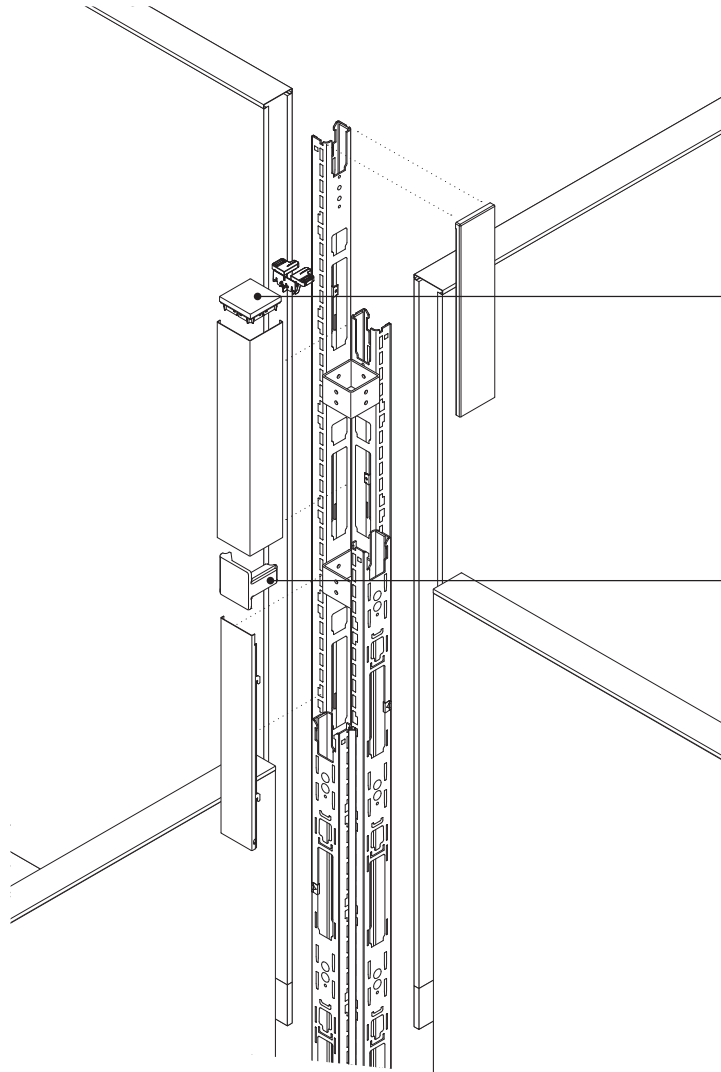

Junction caps are always located at the second tallest panel height. If there are two panels at the same tallest height, the junction cap will be located there.

L to T aligners or 120° to V aligners are required to be specified in certain change-of-height applications to provide consistent alignment of trim pieces.

How to Build Your Own Change-of-Height Applications

Step 1: Draw out the panel application you would like to build (T, X, or Y).

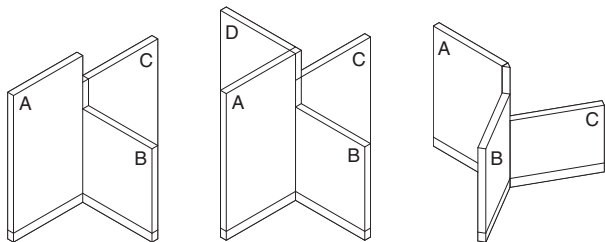

Step 2: Junction Posts
Determine the post heights for each leg of the corner junction corresponding to the panel heights.



Side A (e.g. 78")
Side B (e.g. 66")
Side C (e.g. 54")
Side D (e.g. 42") (For use in X configurations with four different heights only)

Step 3: Junction Blocks
From the list below, select the change-of-height application type that matches your drawing:

- T or Y junction with three different panel heights (go to step 3a).
- X junction with three different panel heights (go to step 3b).
- X junction with four different panel heights (go to step 3c).

Step 3a: If the shortest panel is 48" high or lower, order three blocks.
▶ See specifying page 357.

If the shortest panel is 54" high, order four blocks.
▶ See specifying page 357.

Step 3b: If there are two panels at 78" high and the lowest panel is 54" high, order five blocks.
▶ See specifying page 357.

If there is a panel less than or equal to 48" high and only ONE panel at the tallest height, order three blocks.
▶ See specifying page 357.

For all other change-of-height configurations order four blocks.
▶ See specifying page 357.

Step 3c: For all X junctions with four different panel heights use four blocks.
▶ See specifying page 357.

Step 4: Inside Corner Light Seals



- You will need two inside corner light seals for a T corner and four inside corner light seals for an X corner (none are needed for a Y corner).
 - Inside corner light seals are sold in packages of four.
 - Packages come in three heights: 54", 66", and 78".
 - Specify the height to correspond to the tallest junction and field cut as necessary.
- Inside corner light seal—54"H, package of four **TS754ICLS**
Inside corner light seal—66"H, package of four **TS766ICLS**
Inside corner light seal—78"H, package of four **TS778ICLS**

Step 5: Vertical Trim
Locate the application below that is the same as the application you originally illustrated.
Specify the trims listed in the option you selected below. You will be required to refer back to your original drawing several times to calculate the proper trim heights.

Build Your Own Change-of-Height—Thin Trim, continued

How to Build Your Own Change-of-Height Applications, continued

T Change-of-Height Application (3 heights)

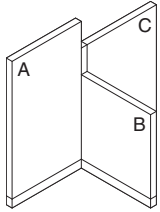

Option 1

Step 2: Vertical Junction Posts

A **TS7__JP**
 B **TS7__JP**
 C **TS7__JP**

Step 3: Junction Blocks -
 see step 3a on page 41

Step 4: Light seals **TS7__ICLS**

Step 5: Trim

Thin end-of-run
 change-of-height = A - C **TS7__TICHT(W)**
 T change-of-height = C - B **TS7__TCTCHT(W)**
 T vertical = C **TS7__TTVT(W)**
 90° change-of-height
 corner cap **TS790COHJC(W)**
 Junction cap aligner **TS7CJCA10**
 (10 pack)

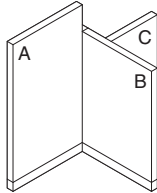

Option 2

Step 2: Vertical Junction Posts

A **TS7__JP**
 B **TS7__JP**
 C **TS7__JP**

Step 3: Junction Blocks -
 see step 3a on page 41

Step 4: Light seals **TS7__ICLS**

Step 5: Trim

Thin end-of-run
 change-of-height = A - B **TS7__TICHT(W)**
 L change-of-height = B - C **TS7__TCLCHT(W)**
 T vertical = C **TS7__TTVT(W)**
 90° change-of-height
 corner cap **TS790COHJC(W)**
 L to T aligner **TS7LTA4** (4 pack)
 Junction cap aligner **TS7CJCA10**
 (10 pack)

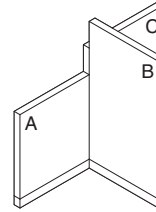

Option 3

Step 2: Vertical Junction Posts

A **TS7__JP**
 B **TS7__JP**
 C **TS7__JP**

Step 3: Junction Blocks -
 see step 3a on page 41

Step 4: Light seals **TS7__ICLS**

Step 5: Trim

Thin end-of-run
 change-of-height = B - C **TS7__TICHT(W)**
 L change-of-height = C - A **TS7__TCLCHT(W)**
 T vertical = A **TS7__TTVT(W)**
 90° change-of-height
 corner cap **TS790COHJC(W)**
 L to T aligner **TS7LTA4** (4 pack)
 Junction cap aligner **TS7CJCA10**
 (10 pack)

Y Change-of-Height Application (3 heights)

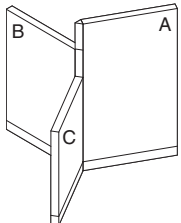

Option 1

Step 2: Vertical Junction Posts

A **TS7__JP**
 B **TS7__JP**
 C **TS7__JP**

Step 3: Junction Blocks -
 see step 3a on page 41

Step 4: Light seal None

Step 5: Trim

120° change-of-
 height = A - B **TS7__T120CHT(W)**
 V change-of-height = B - C **TS7__TVCHT(W)**
 120° corner cap **TS7120JC(W)**
 120° to V aligner **TS7120VA4**

How to Build Your Own Change-of-Height Applications, continued

X Change-of-Height Application (3 heights)

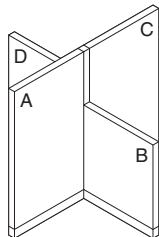

Option 1

Step 2: Vertical Junction Posts

A	TS7__JP
B	TS7__JP
C	TS7__JP
D	TS7__JP

Step 3: Junction Blocks
see step 3b on page 41

Step 4: Light seals **TS7__ICLS**

Step 5: Trim

T change-of-height = A - B **TS7__TCTCHT(W)**
 T change-of-height = A - D **TS7__TCTCHT(W)**
 90° junction cap **TS790JC(W)**
 Two junction cap aligners **TS7CJCA10**
 (10 pack)

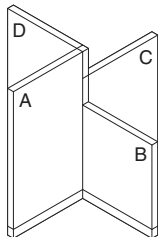

Option 2

A	TS7__JP
B	TS7__JP
C	TS7__JP
D	TS7__JP

Step 3: Junction Blocks
see step 3b on page 41

Step 4: Light seals **TS7__ICLS**

Step 5: Trim

L change-of-height = A - C **TS7__TCLCHT(W)**
 T change-of-height = C - B **TS7__TCTCHT(W)**
 90° junction cap **TS790JC(W)**
 Two junction cap aligners **TS7CJCA10**
 (10 pack)
 L to T aligner **TS7LTA4** (4 pack)

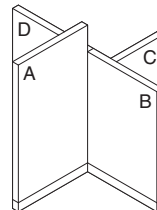

Option 3

A	TS7__JP
B	TS7__JP
C	TS7__JP
D	TS7__JP

Step 3: Junction Blocks
see step 3b on page 41

Step 4: Light seals **TS7__ICLS**

Step 5: Trim

End-of-run change-of-height = A - B **TS7__TICHT(W)**
 T change-of-height = B - C **TS7__TCTCHT(W)**
 90° change-of-height junction cap **TS790COHJC(W)**
 Two junction cap aligners **TS7CJCA10**
 (10 pack)

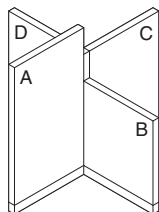

Option 4

Step 2: Vertical Junction Posts

A	TS7__JP
B	TS7__JP
C	TS7__JP
D	TS7__JP

Step 3: Junction Blocks
see step 3b on page 41

Step 4: Light seals **TS7__ICLS**

Step 5: Trim

End-of-run change-of-height = A - C **TS7__TICHT(W)**
 T change-of-height = C - B **TS7__TCTCHT(W)**
 90° change-of-height junction cap **TS790COHJC(W)**
 Two junction cap aligners **TS7CJCA10**
 (10 pack)

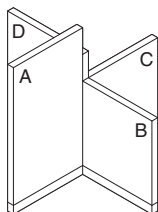

Option 5

A	TS7__JP
B	TS7__JP
C	TS7__JP
D	TS7__JP

Step 3: Junction Blocks
see step 3b on page 41

Step 4: Light seals **TS7__ICLS**

Step 5: Trim

End-of-run change-of-height = A - D **TS7__TICHT(W)**
 L change-of-height = D - C **TS7__TCLCHT(W)**
 90° change-of-height junction cap **TS790COHJC(W)**
 Junction cap aligner **TS7CJCA10**
 (10 pack)

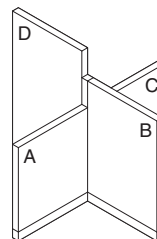

Option 6

A	TS7__JP
B	TS7__JP
C	TS7__JP
D	TS7__JP

Step 3: Junction Blocks
see step 3b on page 41

Step 4: Light seals **TS7__ICLS**

Step 5: Trim

End-of-run change-of-height = D - B **TS7__TICHT(W)**
 Two T change-of-height = B - A **TS7__TCTCHT(W)**
 90° change-of-height junction cap **TS790COHJC(W)**
 Junction cap aligner **TS7CJCA10**
 (10 pack)

Build Your Own Change-of-Height—Thin Trim, continued

How to Build Your Own Change-of-Height Applications, continued

X Change-of-Height Application (4 heights)

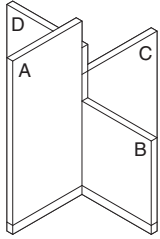

Option 7

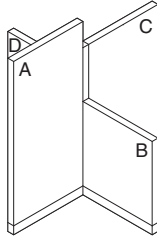

Option 8

Step 2: Vertical Junction Posts

- A **TS7__JP**
- B **TS7__JP**
- C **TS7__JP**
- D **TS7__JP**

- A **TS7__JP**
- B **TS7__JP**
- C **TS7__JP**
- D **TS7__JP**

Step 3: Junction Blocks
see step 3c on page 41

Step 3: Junction Blocks
see step 3c on page 41

Step 4: Light seals **TS7__ICLS**

Step 4: Light seals **TS7__ICLS**

Step 5: Trim

End-of-run change-of-height = A - D

TS7__TICHT(W)

L change-of-height = D - C

TS7__TCLCHT(W)

T change-of-height = C - B

TS7__TCTCHT(W)

90° change-of-height

TS790COHJC(W)

junction cap

TS7CJCA10

Junction cap aligner

(10 pack)

L to T aligner

TS7LTA4 (4 pack)

Step 5: Trim

End-of-run change-of-height = A - C

TS7__TICHT(W)

T change-of-height = C - B

TS7__TCTCHT(W)

T change-of-height = C - D

TS7__TCTCHT(W)

90° change-of-height

TS790COHJC(W)

junction cap

TS7CJCA10

Junction cap aligner

(10 pack)

Practice Examples—Thin Trim

Example One

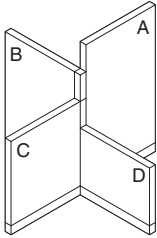

Step 1: Draw out the application - X - 4 Change-of-Height

Step 2: Vertical Junction Posts	Quantity	Style Number
A 66" H	1	TS766JP
B 54" H	1	TS754JP
C 42" H	1	TS742JP
D 30" H	1	TS730JP
Step 3 (a-c): Junction Blocks (3c)	1	TS790JB4
Step 4: Light seal	1	TS766ICLS (4 pack)
Step 5: Trim		
End-of-run change-of-height = A - B	1	TS712TCICHT
L change-of-height = B - C	1	TS712TCLCHT
T change-of-height = C - D	1	TS712TCTCHT
90° change-of-height junction cap	1	TS790COHJC
L to T aligner	1	TS7LTA4 (4 pack)
Junction cap aligner	1	TS7CJCA10 (10 pack)

Note: Junction cap resides at the second tallest panel height. In this case there is a panel higher so it is a 90° change-of-height junction cap instead of a 90° corner junction cap.

Example Two

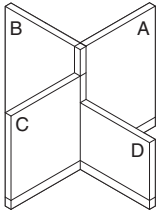

Step 1: Draw out the application - X - 3 Change-of-Height

Step 2: Vertical Junction Posts	Quantity	Style Number
A 54" H	1	TS754JP
B 54" H	1	TS754JP
C 42" H	1	TS742JP
D 30" H	1	TS730JP
Step 3 (a-c): Junction Blocks (3c)	1	TS790JB4
Step 4: Light seal	1	TS766ICLS (4 pack)
Step 5: Trim		
L change-of-height = A - C	1	TS712TCLCHT
T change-of-height = C - D	1	TS712TCTCHT
90° junction cap	1	TS790JC
L to T aligner	1	TS7LTA4 (4 pack)
Junction cap aligner	2	TS7CJCA10 (10 pack)

Note: Junction cap resides at the second tallest panel height. In this case there are two panels at the tallest height so a 90° junction cap would be specified instead of a 90° change-of-height junction cap as in the previous example.

Example Three

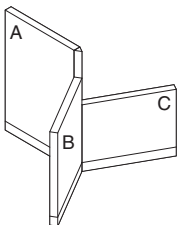

Step 1: Draw out the application - Y - 3 Change-of-Height

Step 2: Vertical Junction Posts	Quantity	Style Number
A 54" H	1	TS754JP
B 42" H	1	TS742JP
C 30" H	1	TS730JP
Step 3 (a-c): Junction Blocks (3b)	1	TS7120JB3
Step 4: Light seal	N.A.	N.A.
Step 5: Trim		
120° change-of-height = A - B	1	TS712T120CHT(W)
V change-of-height = B - C	1	TS712TVCHT(W)
120° corner junction cap	1	TS7120JC(W)
120° to V aligner	1	TS7120A4 (4 pack)

Build Your Own 3" In-Line Junction—Thin Trim

Usage Rules

If you need to add inches to your application while planning, order the following parts in the appropriate heights to create an "I" junction or a 3" in-line junction connection.

Tip: Junctions 48"H or shorter require two junction blocks. Junctions 54"H or higher require three junction blocks.

Normal In-Line Connection

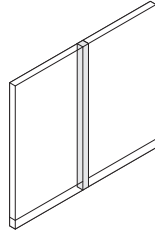

3" In-Line Junction

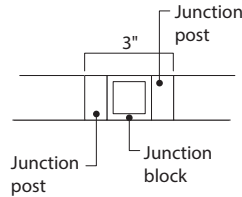
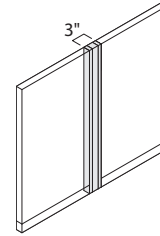

TOP VIEW

How to Build Your Own 3" In-Line Junction

- Step 1:** 2 Panel Junction
TS7___JP
- Step 2:** Junction Blocks (pack of 3 - use 2 or 3 depending on height)
- Step 3:** 1 Junction Cap
TS790JC
- Step 4:** 1 Junction Cap Aligner (pack of 10 - use 1)
TS7CJCA10
- Step 5:** 2 T Vertical Trim
TS7___TTVT

Practice Example

Quantity	Style Number
2	TS754JP
1	TS790JB3
1	TS790JC
1	TS7CJCA10
2	TS754TTVT

Build Your Own Stacking Junctions—Thin Trim

Stacking junctions have several implications on the actual frame components of the panel, as well as how the frame is trimmed.

Note: Same height stacking junctions are supported as style numbers, see page 345. This section should only be used when you need to stack and there is not a pre-configured stacking junction style number.

When stacking be sure to follow the steps listed below:

Step 1: Start by drawing out your base application ONLY (do not include stackers).

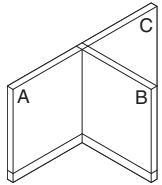

Corner

Example: 42"H T panel application label one panel A, one panel B, and one panel C.

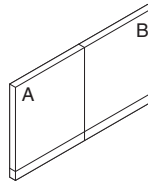

In-Line

Example: 42"H in-line panel application label one panel A and one panel B.

Step 2: Label each panel with a letter and dimensions (remember to work counterclockwise).

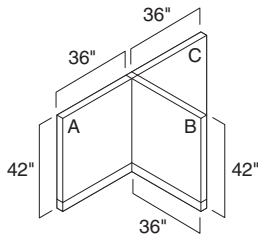

Corner

Example: 42"H T panel application label one panel A, one panel B, and one panel C.

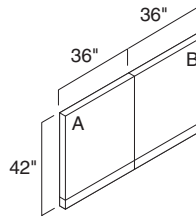

In-Line

Example: 42"H in-line panel application label one panel A and one panel B.

Step 3: Omit **ALL** trims (this will omit the junction cap and aligners as well).

Step 4: Determine where you would like stacking junctions on your application and label them with a letter and dimension.

Remember: Maximum height that an Answer panel can reach is 90". Maximum height that can be stacked on a base panel is 36" consisting of one 24"H and one 12"H or two 18"H stacking junctions.

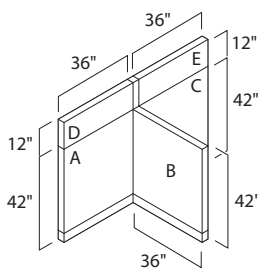

Corner

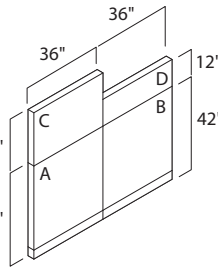
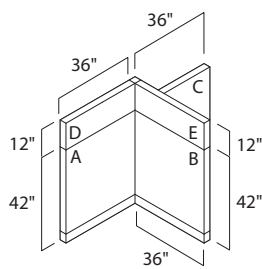

In-Line

Step 5: Look at your application in total. Does your application have an in-line or corner (L, T, X, V, or Y) stacking junction?

- For in-line stacking, go to step 6
- For corner (L, T, X, V, or Y) stacking go to step 7

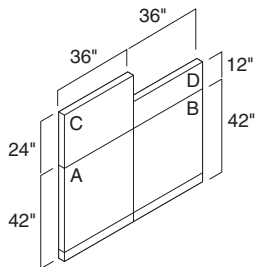

Step 6: In-line stacking junctions

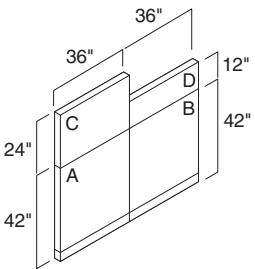

Step 6a: Specify in-line stacking junction for the shared junction. The height specified is the shortest height of the stacking junction. In this example it would be the height of stacking junction D (12").

Step 6b: Specify an end-of-run stacking junction for the difference between the tallest stacking junction and the lowest stacking junction. In this example it would be the height of stacking junction C minus the height of stacking junction D (24" - 12" = 12").

Step 6c: Go to step 7 to specify end-of-run stacking junctions for the stacking junctions that are not in-line. To complete specifying the stacking junctions in this example, one 24" end-of-run and one 12" end-of-run stacking junction would need to be specified.

Step 7: Corner (L, T or X, V, or Y) stacking junctions

Look at each panel individually. Start with panel A and determine what you would like to stack to that panel (if anything). Repeat on the remaining panels in the application.

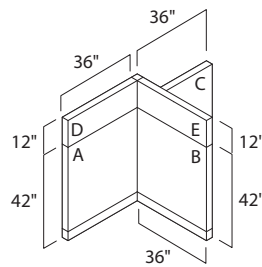
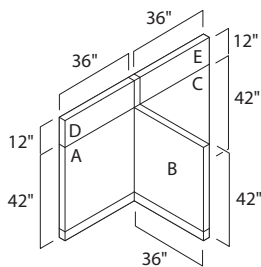

- Base panel A: Add 12" thin end-of-run stacking junction (Panel D)
- Base panel B: No change
- Base panel C: Add 12" thin end-of-run stacking junction (Panel E)
- Specify the proper height and type of stacking junction
 1. End-of-run stacking junction
 2. L, T, X, V, or Y stacking junction

- Base panel A: Add 12" thin end-of-run stacking junction (Panel D)
- Base panel B: Add 12" thin end-of-run stacking junction (Panel E)
- Base panel C: No change

Stacking junction panel D: 12" stacking junction requires one 12" end-of-run stacking junction and a 12" "L" to be shared with panel E

Stacking junction panel E: 12" stacking junction requires one 12" end-of-run stacking junction

- Stacking junction panel D: 12" stacking junction requires two 12" end-of-run stacking junctions
- Stacking junction panel E: 12" stacking junction requires two 12" end-of-run stacking junctions

- Note:*
1. Corner stacking junctions are created by attaching thin end-of-run stacking junctions and junction blocks.
 2. Thin end-of-run stacking junctions are also used when creating an in-line change-of-height condition.
 3. In-line stacking junctions are only used when creating in-line stacking conditions when adjacent panels are the same height.

► See page 346 to specify.

Build Your Own Stacking Junctions—Thin Trim, continued

Step 8: Stacking horizontal frame packages

Each stacking junction needs to be connected by at least one stacking horizontal frame package.

If one side of the panel section has two stacking junctions, and the other side has one, two stacking horizontal frame packages need to be specified.

If there is one stacking junction on both sides of the panel, specify one stacking horizontal frame package to be shared between the two stacking junctions.

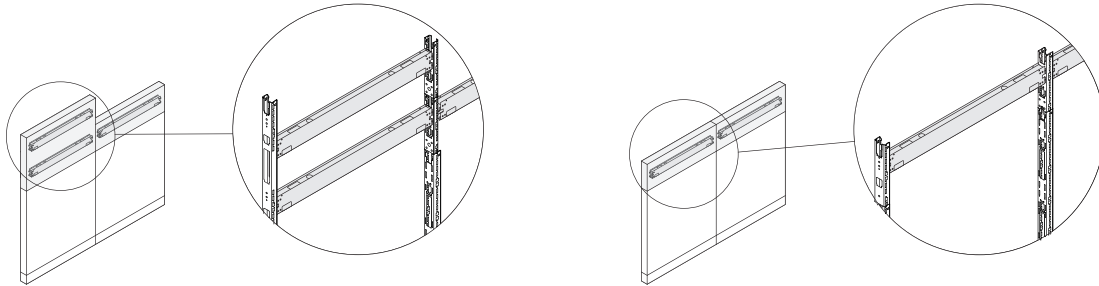

▶ See page 362 to specify.

Step 9: Junction blocks

Junction blocks are required at the top of each junction whenever there are two or more junctions or stacking junctions adjacent to each other in a corner application.

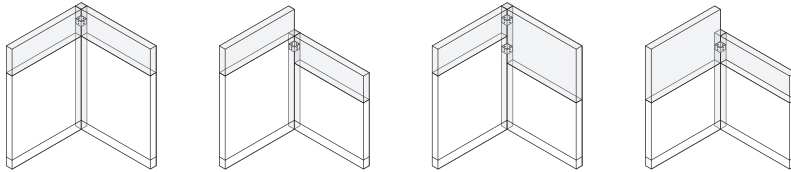

▶ See page 357 to specify.

Step 10: Junction caps and aligners

Now that the application is constructed, trims need to be added (since ALL trims were omitted in step 2).

90° Applications (In-Line, L, T, and X)

- Same height base application stacking to same height application
- Change-of-height base application stacking to a change-of-height application
- Change-of-height base application stacking to same height application
- Same height base application stacking to change-of-height application

Same height base application stacking to same height application (see drawing)

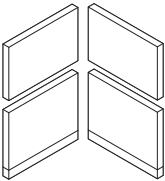

Specify: Junction cap: 90° corner
 Junction cap aligner: Number required is equal to the number of panels connecting to the junction cap

Change-of-height base application stacking to a change-of-height application (see drawing)

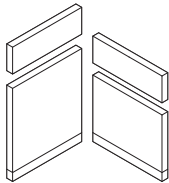

Specify: Junction cap: 90° corner change-of-height
 Junction cap aligner: Number required is equal to the number of panels at the second tallest height

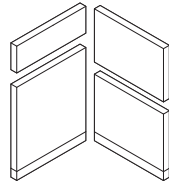
Step 10: Junction caps and aligners, continued**Change-of-height base application stacking to same height application (see drawing)**

Specify: Junction cap: 90° corner
Junction cap aligner: Number required is equal to the number of panels connecting to the junction cap

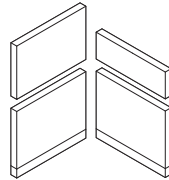
Same height base application stacking to change-of-height application (see drawing)

Junction cap: 90° corner change-of-height
Junction cap aligner: Number required is equal to the number of panels at the second tallest height

120° applications (V or Y) - All 120° applications require:

Junction cap: 120° junction cap
Junction cap aligner: Number required is one less than the number of panels connecting to the junction cap

For complete list of style numbers:

Junction cap ▶ See page 358.
Junction cap aligner ▶ See page 358.

Step 11: Trim**90° Applications****Level 1**

One panel at the tallest height
Two panels at the tallest height in an "L" configuration
Two panels at the tallest height along the spine of a "T" configuration
Look at both sides of the spine individually as two T trims (different heights) will need to be specified.
Three panels at the tallest height

Level 2

Two panels at the second height or higher in an "L" configuration
Two panels at the second height along the spine of a "T" configuration

Three panels at the second height or higher

Level 3

Three panels at third height

120° Applications**Level 1**

One panel at the tallest height
Two panels at the tallest height in a "V" configuration

Level 2

Two panels at the second height or higher in a "V" configuration

Required to Specify

End-of-run/change-of-height trim = tallest height minus second height
L trim = tallest height minus the third height (could be to the floor)
T trim = tallest height minus the third height (could be to the floor).

T trim = tallest height minus the fourth height (could be the floor).

L trim - second height minus third height
T trim = second height minus the third height (could be to the floor).
Look at both sides of the spine individually as two T trims (different heights) will need to be specified.
T trim - second height minus third height

T trim - third height minus fourth height

Required to Specify

120° change-of-height trim = tallest height minus second height
V trim = tallest height minus the third height (could be to the floor)

V trim = second height minus the third height (could be to the floor)

Step 12: Inside corner light seal

Specify Inside corner light seal to match the overall height of the lower panel in the application (used only on 90° applications).

Step 13: Change-of-height aligners

If you have both L and T aligners at one junction, an L/T aligner is needed.
If you have both 120° and V trims at one junction, a 120°/V aligner is needed.

Reconfiguring with Answer—General Guidelines

General Junction Guidelines

Junctions manufactured **before** 10/10/11 are purpose built and have specific features.

- Skin clip attachment locations every 12"
- Cannot accept 6" technology skin
- Cannot accept the open base trim
- Large opening for routing power and data is only at worksurface height
- Corner junctions are purpose built and cannot change configuration from one application to the next

Junctions manufactured **after** 10/10/11 are universal corner junctions.

- Skin clip attachment locations every 6"
- Can accept 6" technology skin
- Can accept the open base trim
- Large openings for routing power and data are located every 12" inside the panel
- Corner junctions are considered universal. The junction can easily be transformed from one configuration to another (i.e. turn an L- into a T-junction)

Purpose built and universal corner junctions can be used in the same application.

Junctions Manufactured Before and After 10/10/11

In-line junctions can be used with Oval, Square, or Thin panel trim. In-line junctions manufactured before OR after 10/10/11 can be used with Thin trim. The only differences between the junctions are those listed in the general guidelines above.

Corner Junctions

Same Height

- Same height are interchangeable between Oval, Square, or Thin panel trim.
- Same height corner junctions manufactured before OR after 10/10/11 can be used with Thin trim.

• **Universal junction configuration** (manufactured after 10/10/11)

- Post and block configuration – all the posts are the same height.
- Can be reconfigured to another style corner junctions.
- Can accept Oval, Square, or Thin panel trims.

Examples:

1 Change an L to a T

- Add one junction post
- Replace the L trim with a T trim
- Add a junction cap aligner
- Inventory L trim

2 Change an L to an X

- Add one junction post
- Add two junction cap aligners
- Inventory L trim

3 Change a T to an L

- Remove one junction post
- Remove one junction cap aligner
- Replace the T trim with an L trim

4 Change an X to an L

- Remove two junction posts
- Remove two junction cap aligners
- Add an L trim

5 Change an X to a T

- Remove one junction post
- Remove one junction cap aligner
- Add a T trim

• **Purpose Built Junction configuration** (manufactured before 10/10/11)

- Cannot be reconfigured to be another style corner junction. If desire to change from an L- to a T-junction, the entire junction must be changed out.
- Can accept Oval, Square, or Thin panel trims.

Corner Junctions – Change-of-Height

Thin Trim

- Change-of-height corner junctions can only accept universal junctions manufactured after 10/10/11.
- Junction posts will **only go up to the height of the panels**

Example:

1 42/54" L-junction

- One junction post at 42"H
- One junction post at 54"H

- Cannot accept purpose built change-of-height junctions manufactured before 10/10/11.
- When reconfiguring from Square or Oval trim to Thin trim, purpose built corner junctions must be change to universal corner junctions.

Junctions Manufactured Before and After 10/10/11, continued

Corner Junctions – Change-of-Height, continued

Oval and Square Trim

- Can accept junctions manufactured before 10/10/11 (purpose built configuration).
- Can accept junctions manufactured after 10/10/11 (universal junction configuration).
- Junction posts will go up to the **highest** panel height

Example:

- ❶ 42/54" L-junction
 - Two junction posts at 54"H

End-of-Run Junctions

Thin Trim

- Thin trim requires Thin end-of-run junctions
- When reconfiguring from Square or Oval trim to Thin trim, all end-of-run junctions must be changed to Thin end-of-run junctions

Square and Oval Trim

- The end-of-run junction utilized in a Square or Oval application is the same as the in-line junction.
- Square and Oval applications cannot use Thin end-of-run junctions.

Stacking Junctions

- Stacking junctions manufactured before 10/10/11 can be stacked on purpose built junctions (before 10/10/11) or universal junctions (after 10/10/11).
- Stacking junctions manufactured after 10/10/11 can be stacked on purpose built junctions (before 10/10/11) or universal junctions (after 10/10/11).

Trims

Trim style must be consistent across the entire application. Trim styles cannot be mixed and matched across applications.

Example:

- ❶ Square top caps cannot be used with Thin vertical trims. The entire application must be Thin trim (top caps and vertical trim) OR the entire application must be Square trim (top caps and vertical trim).

New Junctions (after 10/10/11) to New Junctions

End-of-Run Junctions

- **End-of-run junction** includes junction post plus an end-of-run trim and aligner.
 - When reconfiguring a junction post can be used at an end-of-run or as a post to make up a 90° or 120° corner.
 - End-of-run junctions are not the same as in-line junctions.

In-line Junctions

- **End-of-run junction** includes a junction and an in-line aligner.
 - In-line junctions cannot be used at an end-of-run with Thin trim.
 - In-line junctions can be used at an end-of-run with Square or Oval trim.
 - In-line junctions **cannot** be used at a corner junction.

Corner Junctions

- Universal corner junctions are made up of blocks and posts.
- Universal corner junctions can be changed from one configuration (i.e. L) to another configuration (i.e. T, X, V, or Y) by adding blocks and/or junction posts.
- When reconfiguring corner junctions, additional corner trim and aligner pieces will need to be ordered.

Reconfiguring with Answer—General Guidelines, continued

New Junctions (after 10/10/11) to New Junctions, continued

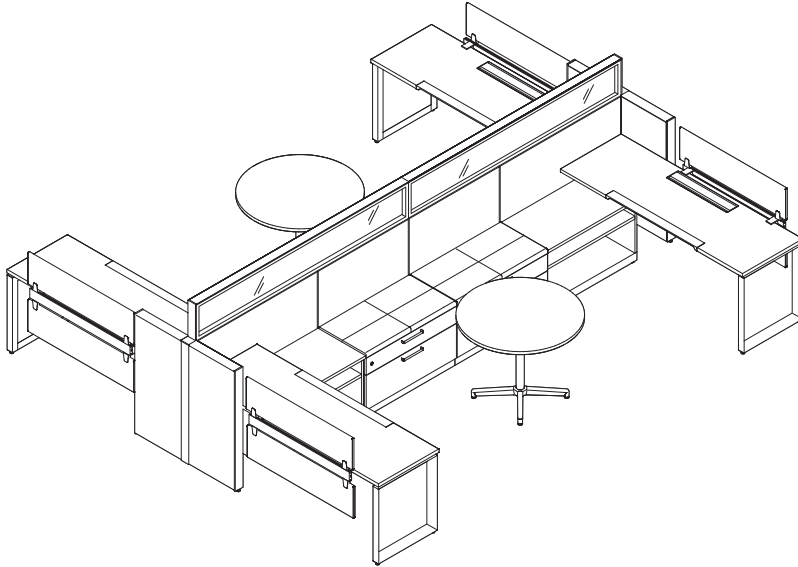

Current Style Number (Square before 10/10/11)			New Style Number (Thin after 10/10/11)		
Qty	Style Number	Description	Qty	Style Number	Description
4	TS718SHF	Frame—Horizontal Package, Square, 18"W, change-of-height at one end of top cap	4	TS718THF	Frame—Horizontal Package, Thin, 18"W
2	TS736SHF	Frame—Horizontal Package, Square, 36"W (omit top cap)	2	TS736THF	Frame—Horizontal Package, Thin, 36"W
4	TS742SEPJ	Junction—End-of-Run, Square, 42"H	4	TS742TEPJ	Junction—End-of-Run, Thin, 42"H
2	TS742SIPJ	Junction—In-Line, Square, 42"H	2	TS742TIPJ	Junction—In-Line, Thin, 42"H
2	TS7454STPJ	Junction—T Junction	2	TS7454TCTJ	Junction -T, Change-of-Height, Thin, 42" to 54" to 42"
4	TS712SCHS	Change-of-Height Trim, Square	N.A.	N.A.	N.A.
2	TS748SHF	Frame—Horizontal Package, Square, 48"W	2	TS748THF	Frame—Horizontal Package, Thin, 48"W
1	TS754SIPJ	Junction—In-Line, Square, 54"H	1	TS754TIPJ	Junction—In-Line, Thin, 54"H
2	TS772STC	Spanning Top Cap—Square, 72"W	2	TS772TTC	Spanning Top Cap—Thin, 72"

The following style numbers can be re-used in this configuration:

4	TS73618TKF	Panel Skin—Tackable Acoustical, 40" x 18", Floor			
4	TS73636TK	Panel Skin—Tackable Acoustical, 36" x 36"			
4	TS73648TK	Panel Skin—Tackable Acoustical, 36" x 48"			
2	TS71284SPW	Window—Single Pane			
2	TS7SWS	Spanning Window In-Line Support			
4	WS2472S	Worksurface—Straight			
4	UTTRMN	Tray—Universal Worksurface, Modular			
4	TS7WKSPT	Reinforcing Channel, 57"W			
4	DSR 40	SOTO Rail, 40"W			
8	CQSF4212	Screen—Personal/Modesty Fixed			
4	UFC24	Leg—Universal Closed			
4	RLF18361AP	Lateral—Universal, Proud Front Steel, 1.5-High Open/Open			
4	RLF18361BP	Lateral—Universal, Proud Front Steel, 1.5-High Dwr/Dwr			
4	RPDC1836P	Cushion			
2	BFR36	Table—Round			
2	BX26	Base—X			
2	USSBR	Bracket—side support			

Need To Order			Extra (to inventory)		
Qty	Style Number	Description	Qty	Style Number	Description
4	T521710SR	Thin Trim Top Cap—18"W – Service Part	4	N.A.	Square Trim Top Cap—18"W, change-of-height one end
N.A.	N.A.	N.A.	N.A.	N.A.	N.A.
4	TS742TEPJ	Junction—End-of-Run, Thin, 42"H (includes junction and trim)	4	TS742SEPJ	Junction—End-of-Run, Square, 42"H (includes junction and trim)
N.A.	N.A.	N.A.	N.A.	N.A.	N.A.
2	TS7454TCTJ	Junction—T, Change-of-Height, Thin, 42" to 54" to 42"	2	TS7454STPJ	Junction—T, Junction
N.A.	N.A.	N.A.	4	TS712SCHS	Change-of-Height Trim, Square
N.A.	N.A.	N.A.	N.A.	N.A.	N.A.
N.A.	N.A.	N.A.	N.A.	N.A.	N.A.
2	TS784TTC	Spanning Top Cap—Thin, 84"	2	TS784STC	Spanning Top Cap—Square, 84"

Reconfiguring with Answer—General Guidelines, continued

SmartTools Specification Tips

- Before 10/10/11 Oval and Square junctions were manufactured with purpose build junctions. Starting 10/10/11 Oval and Square junctions began being manufactured with universal junctions. The style number stayed the same but the junction construction changed.
- SmartTools designates new and old junctions. Old junctions are designated with an asterisk (*).
- SmartTools provides the ability to change between new and old junctions, as well as connect them together where applicable.
- For assistance in reconfigurations, SmartTools allows designers to create "alternatives". Alternatives will allow designers to create an original application (alternative one) and make a copy of it (alternative two). The designer can then make design changes to alternative two to reflect what the reconfigured space will look like.
- Once design changes are made, the designer will be able to use SmartTools outputs to compare alternative one to alternative two to determine the following information:
 - Bucket one: What product from alternative one can be used in alternative two.
 - Bucket two: What product from alternative one will not be needed in alternative two.
 - Bucket three: What additional product will be needed in alternative two.
 - Since universal junctions can be broken down into individual components (blocks, posts, light seals, and trim), to re-use the maximum number of parts a designer can manually determine if a match can be made between the parts left in bucket two and the parts needed in bucket three.

Base Horizontal Frame Packages—Thin Trim

Base horizontal frame packages include horizontal connecting bars that lock into vertical junctions and complete the structure of a panel. A top cap and pair of base trims are also included. Cable tray and base cable tray are available as options.

► Specifying, page 360

Top cap snaps onto top of panel skins. Top caps to accommodate change-of-height are also available. Wood veneer is available as an option.

Quick lock connects horizontal bars to vertical junctions for quick assembly.

Horizontal connecting bars lock into vertical junctions. The top bar can be lowered to a maximum of 24" from the top position. The bottom bar must always be positioned in the lowest slot in a junction.

Optional base cable tray can be used to support lay-in of cables.

Big open base option includes vertical trim.

Optional cable tray can be used for additional support of cables. Additional cable trays can be installed and arranged at various heights within the frame for communications access and cable routing.

Base trims, open base, or big open base trim styles are available on panels with Thin trim style.

Base trim with knockouts accommodates power and communication terminations. Top knockout is for power, bottom knockout is for communication. Filler to close unused openings is available from Service Parts (**TS7BTFSR**).

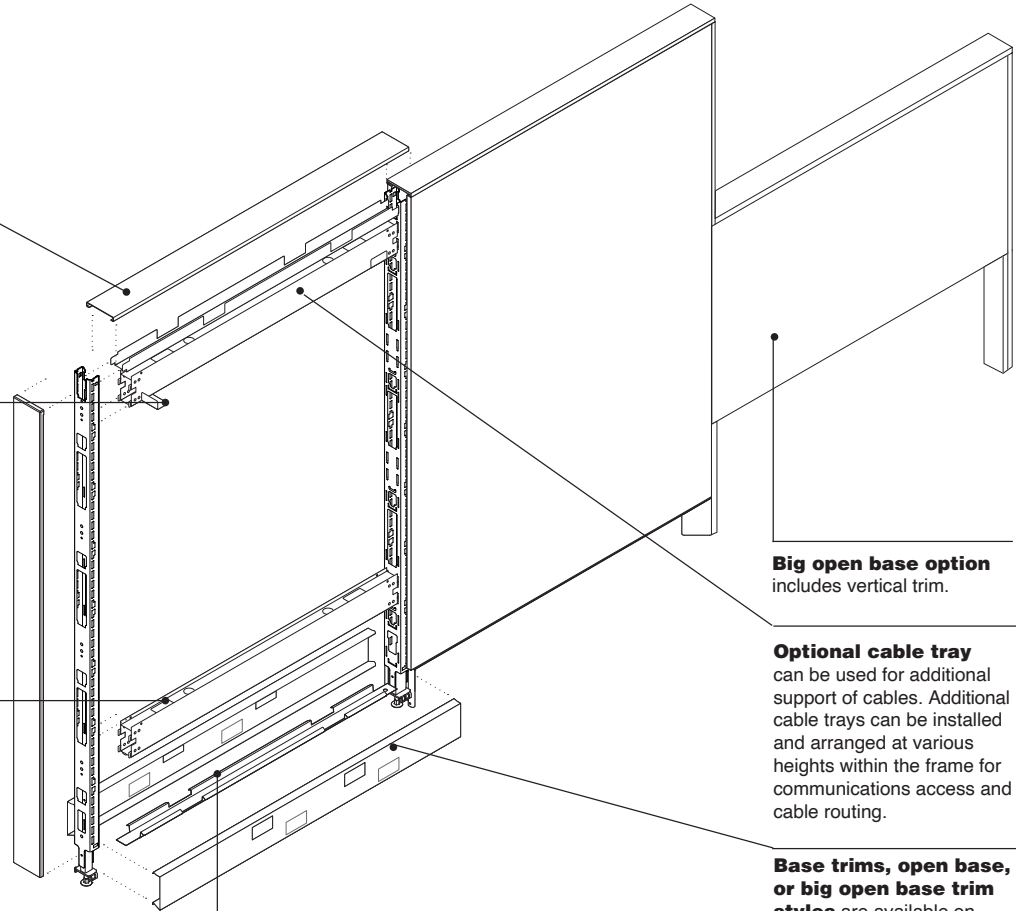

Actual Dimensions

Width 17¹³/₁₆" , 23¹³/₁₆" , 29¹³/₁₆" , 35¹³/₁₆" , 41¹³/₁₆" , 47¹³/₁₆" , 59¹³/₁₆" , and 71¹³/₁₆"

Base trim height 3³/₄"

Big open base height 9¹/₁₆"

Receptacle Opening

Width of opening 2⁵/₈"

Height of opening 1³/₈"

Product Details

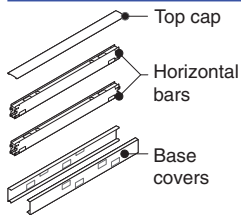

Horizontal frame packages are available when you want to build up your own panel. The package includes all the components of a panel except the skins so you can order the skins separately to mix combinations of skin surface materials and colors. These frame packages do not include vertical junctions. Options for big open base and open base are available. Cable trays and base cable trays are optional.

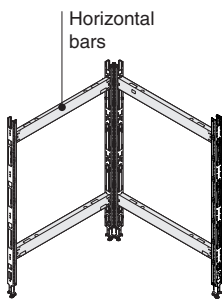

Two horizontal connecting bars must be used in each base panel.

Horizontal bars determine panel width. They are not dedicated to a specific panel height; any horizontal bar can be used or reused with any junction height.

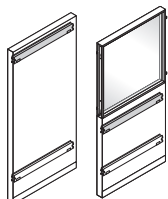

Top horizontal bar may be lowered to allow for a 12"H, 18"H, or 24"H glass window to be placed at the top of the panel. Bottom horizontal bar in base panel must remain in lowest position.

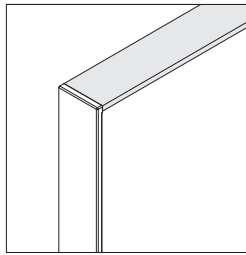

Top caps are available in three styles - thin, square, and oval. This section covers Thin trims. Horizontal frame packages should be specified with Thin trim. Thin, square, and oval top caps can not be mixed between adjacent panels.

Tip: Change-of-height top cap option is only needed when using in-line change-of-height.

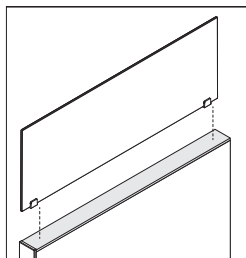

Omit top cap option is available and should be selected when adding a frameless glass screen to the top of the panel, when spanning a single top cap across multiple panels, or when adding a Universal or Sarto screen to the top of the panel.

Spanning top caps are available for Thin trims.

When spanning a single top cap across multiple panels, select the omit top cap option and specify a spanning top cap separately. Top cap width must match total width of spanned panels.

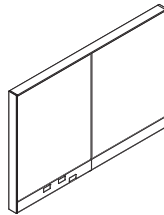

Spanning top caps can only be used in an in-line condition. They cannot span over a corner junction.

Spanning top caps can be used on any panel height.

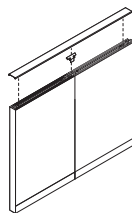

In-line spanning top cap lightseals should be specified separately for each in-line panel joint the top cap spans.

Omit base trim option should be selected when using skins to the floor.

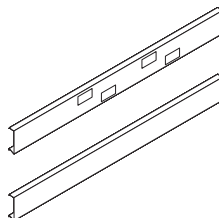

Base trims are available with or without knockouts. Base trims with knockouts accommodate power and communication terminations.

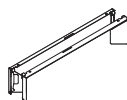

Open base trims are available. They do not accommodate power and data routing or entry in the base. Open base trim can only be added on a junction manufactured on or after October 10, 2011.

Open base trims occupy the same space as the standard base trims. Open base trims occupy the bottom 3¾" of the panel; the height of the opening is 2½".

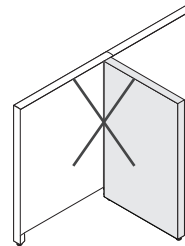

A panel with open base trim cannot serve as the spine panel in an off-module connection.

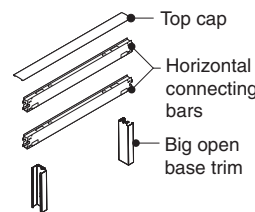

Big open base option is available on Thin trim panel. The horizontal frame package includes two inside vertical trims in addition to two horizontal connecting bars and a Thin trim top cap.

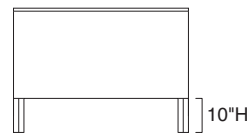

Big open base option provides a larger open base aesthetic for the panel. The opening is about 10"H.

When the big open base option is specified, big open base skins must be used.

When big open base is used, power is available only at 20"H or higher.

Big open base trim package is available for reconfiguring a panel segment to the big open base. The big open base trim package includes two inside vertical trims. The big open base reconfiguration package is **TSBBOBTRM**.

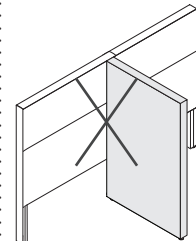

An off-module connector cannot be used on a spine wall with big open base.

For a power and data infed cover for use with Answer panel or Answer Beam big open base trim, contact Specials.

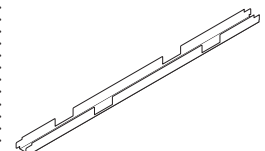

Cable tray can be positioned every 6" vertically above the base to support cable routing.

Cable tray can accept added cable carriers attached below tray to expand horizontal cable management options.

▶ See *Montage Specification Guide* for cable carrier (**ZCC**).

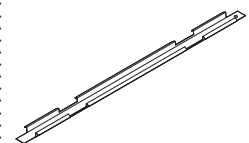

Base cable tray is used only in the base to support lay-in cable routing in the base. Base cable tray cannot be used if omit base trim option is selected for one or both sides of panel or if open base trim is used.

Base Horizontal Frame Packages—Thin Trim, continued

Connections

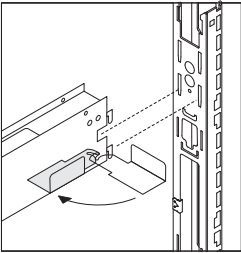

Quick lock on both ends of the panel's horizontal connecting bars engage the junction in a tight structural connection.

Wiring & Cabling

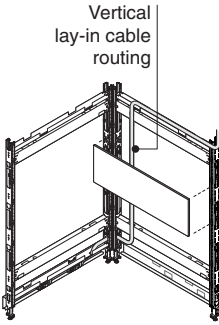

Vertical lay-in cable routing can be accommodated behind skins.

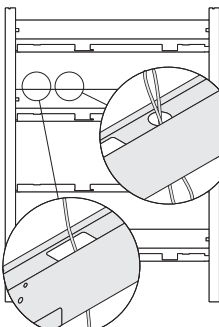

As an alternative to lay-in cable routing, vertical routing of power and cables through panel interior can be accommodated by openings in horizontal connecting bars. Also, see lay-in utility packages for vertical lay-in of power and cables.
▶ Page 166

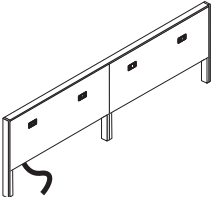

Power and data enter a panel with big open base from underneath the panel. Route power and data up through large vertical routing openings in the horizontal bar. Use a multipurpose infeed to bring power into a panel with big open base.

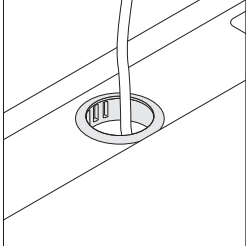

Feed-through horizontal connecting bar cable sleeves can be added in the field to finish the exposed metal edges of vertical cable pass-through openings.

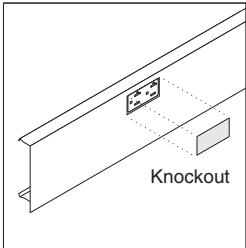

Knockouts in base trim can be removed in the field where needed. Knockout dimensions are 1³/₈"H by 2⁵/₈"W.

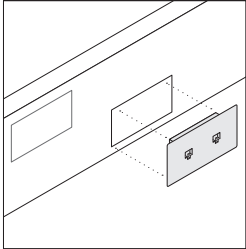

Communication outlets attach to openings in panel base trim. Order communication outlets from an outside vendor. Knockouts for communication in base accommodate modular furniture size only.

Surface Materials

Top cap base trim, open base trim, and big open base vertical trim

- Paint color chosen on base trim will also apply to the top cap. They are not chosen independently.
 - Wood veneer (option)
- Tip: Answer panel wood trims are only available with quarter-cut finishes with the exception of maple finishes. Maple on wood trims is only available with flat-cut finishes. For ordering simplicity, both flat-cut and quarter-cut finishes can be specified on panel trims. However, for all finishes except maple, if a flat-cut finish is selected, the trims will have the coordinating quarter-cut finish. For maple finishes, if quarter-cut is selected, the trims will have the coordinating flat-cut finish. Blending panel trims with other wood products that have flat-cut finishes will be visually acceptable for most applications. If a more exact match is desired for non-maple finishes, please specify quarter-cut finishes for the entire project. If a more exact match is desired for maple finishes, please specify flat-cut finishes for the entire project.*

Horizontal connecting bars

- Black paint
- Tip: Components are hidden when properly installed.*

Application Topics

Use a cable tray to provide extra support for 60"W and 72"W full skins where people may lean against the panel.

Stacking Horizontal Frame Packages

Stacking horizontal frame package provides structural stability for stacking junctions.
▶ Specifying thin, page 362

Each stacking junction is specified separately.
▶ Page 345

When stacking, vertical trim must be specified separately to span the full-height of the base junctions plus the stacking junction.

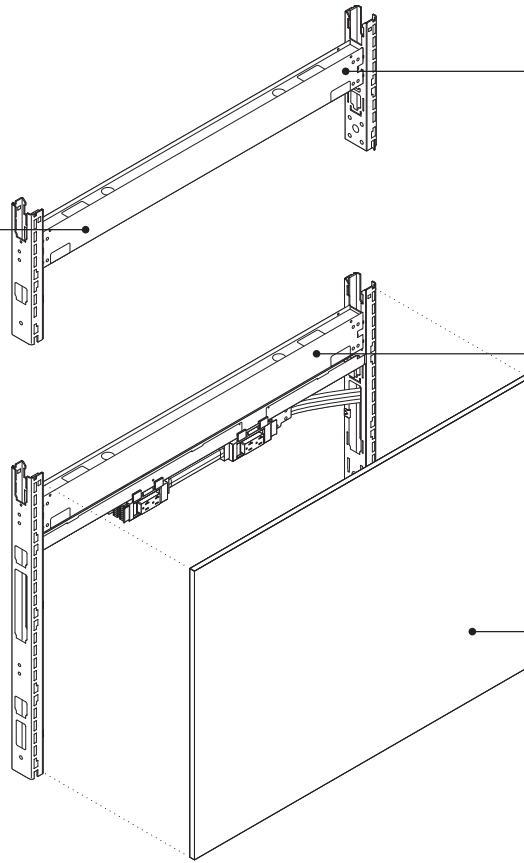

Each stacking segment must have one horizontal connecting bar.
Exception: If a window is used with stacking junctions, a horizontal connecting bar is not needed.

Horizontal connecting bar is included with each stacking horizontal frame package.

Skins, ordered separately, are added to both sides of stacking frame.

Actual Dimensions

Width 17¼", 23¼", 29¼", 35¼", 41¼", 47¼", 59¼", and 71¼"

Product Details

Stacking horizontal frame package includes one horizontal connecting bar. Stacking junction is not included.

Stacking horizontal frame package is available in eight widths— 18", 24", 30", 36", 42", 48", 60", and 72"—to match panel width. These horizontal connecting bars are identical to those in horizontal frame packages and can be re-used with any type of junction.

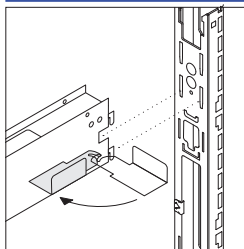
Connections

Quick-lock mechanism on the horizontal connecting bar engages the stacking junction in a tight structural connection.

Base panel must always have two horizontal connecting bars.

Wiring & Cabling

Vertical lay-in cable routing

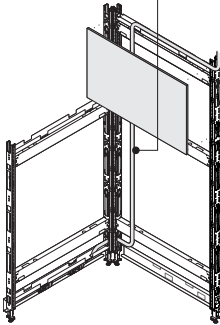

Vertical lay-in cable routing can be accommodated behind skins.

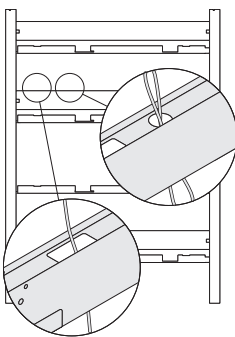

Vertical routing of power and cables through panel interior is accommodated by openings in horizontal connecting bars.

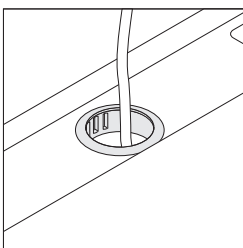

Feed-through horizontal connecting bar cable sleeves can be added in the field to finish the exposed metal edges of vertical cable pass-through openings.

Power kit installation for stacking components is the same process as for installation in base panels.

Surface Materials**Stacking horizontal frame package**

- Black
- Tip: Components are hidden when properly installed.*

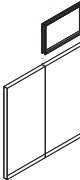
Application Topics

When stacking a 12"H, 18"H, or 24"H window, a stacking horizontal frame package is not needed. Remember, the base panel always has two horizontal connecting bars for support.

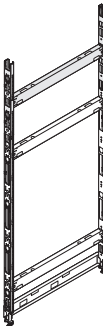

When double stacking junctions, each stacking junction must have a horizontal beam.

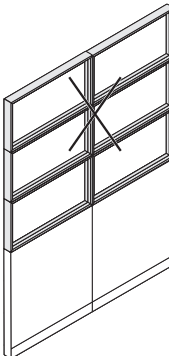

No more than two windows can be stacked on top of each other.

Stacking horizontal frame package

is used when additional horizontal bar is needed in off-module application. See off-module guidelines.

Stacking Stability Guidelines

provides detailed information on applications.

▶ Page 140

Frameless Glass Screens with Recessed Attachment—Thin Trim

Frameless glass screen with recessed attachment can be added to the top of a panel to help define space and provide some privacy while still providing access to natural light and promoting communication between adjacent workers.

► Specifying, page 364

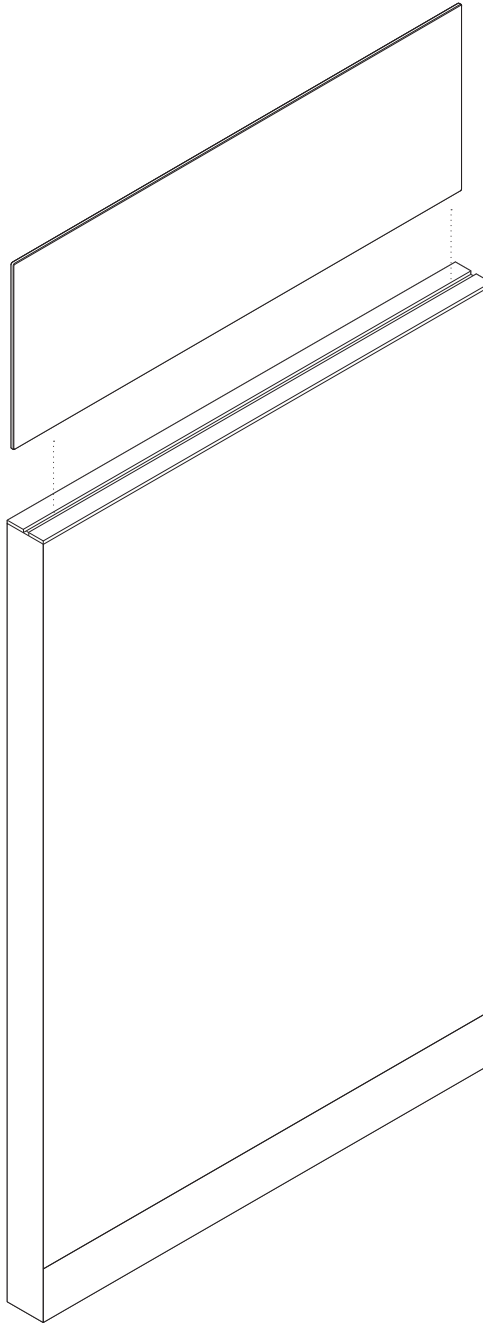

Actual Dimensions

Glass Width—standard: 23⁷/₈", 29⁷/₈", 35⁷/₈", 41⁷/₈", 47⁷/₈", 53⁷/₈", 59⁷/₈", 65⁷/₈", 71⁷/₈", 77⁷/₈", 83⁷/₈", 89⁷/₈", and 95⁷/₈"

Glass Width—change-of-height one end Thin trim: 23⁷/₁₆", 29⁷/₁₆", 35⁷/₁₆", 41⁷/₁₆", 47⁷/₁₆", 53⁷/₁₆", 59⁷/₁₆", 65⁷/₁₆", 71⁷/₁₆", 77⁷/₁₆", 83⁷/₁₆", 89⁷/₁₆", and 95⁷/₁₆"

Glass Height: 9⁵/₁₆", 15¹/₂", 21¹/₁₆", and 27⁷/₈"

Glass Thickness: 3/8"

Product Details

Frameless glass screen with recessed attachment is secured to horizontal connecting bar by supports below the top cap. Two brackets are used below the top cap to attach the glass to the panel on 24"–66"W panels. Three brackets are used on panels 72" and wider.

Frameless glass screens with recessed attachment can be used on panels with thin profile trim.

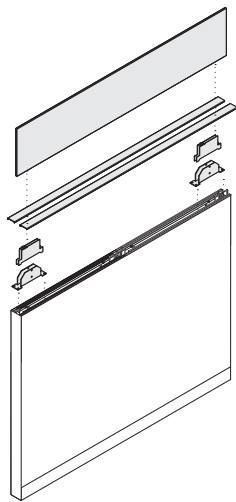

Frameless glass kit includes glass screen, supports, and top caps.

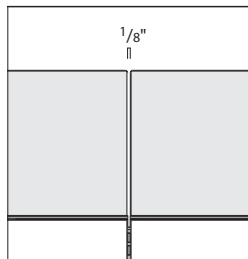

Gap between adjacent glass screens is 1/8".

Surface Materials

Glass

- 6500 Clear Glass
- 6530 Frosted Glass

Tip: Frosted glass for recessed frameless glass attachment is a laminated construction. There may be variation in color, texture, and finish between the sample of 6530 Frosted Glass and the actual product.

Top cap

- Paint
- Wood veneer

Application Topics

Frameless glass screen can be placed on the top of a panel only. Top beam in the panel must be located in the top position of the frame in order to support frameless glass. Frameless glass can be used on base panels or stacking panels.

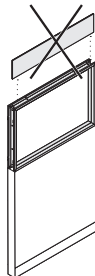

Frameless glass screen cannot be used when a window is located in the top position of the panel.

Frameless glass screen cannot be added to a panel segment with a 6" stacker.

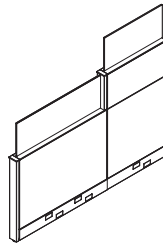

At an in-line change-of-height condition, a change-of-height top cap should be specified. Change-of-height top cap option is available to allow for positioning of glass next to change-of-height trim on one side only. Glass is shortened and top cap provided supports change-of-height on one end only. A change-of-height top cap is not needed at a corner change-of-height condition.

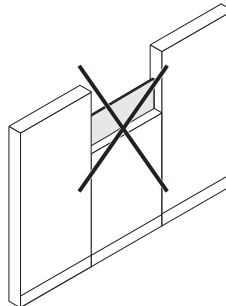

Frameless glass screen will not fit between two in-line change-of-height trims.

Frameless glass kit is available without glass screen to accommodate customer's own glass. See chart of field installed glass size requirements for specific dimensions required for glass to fit in frameless glass brackets. Steelcase recommends the use of safety glass meeting ANSI Z97.1 for field installed glass. Check with your local building authority for requirements in your area.

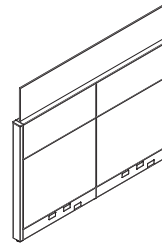

A single frameless glass screen can span over two or more in-line panels up to 96".

Frameless glass screens with recessed attachment cannot span a corner junction.

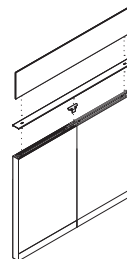

In-line spanning top cap lightseal must be specified separately when used in this application. Spanning top cap lightseal attaches to underside of top cap to fill space between skin lightseals. Specify one for each in-line junction the frameless glass screen spans.



Before November 2012



After November 2012

Plastic end-of-run and junction cap aligners manufactured after November 2012 will have features to accommodate recessed frameless glass. Aligners manufactured before November 2012 will not be able to accommodate recessed frameless glass and new aligners will need to be ordered.



Each Answer frameless glass with recessed attachment kit will come with two aligners to align top caps when two frameless glass kits are used in an in-line condition.

When specifying frameless glass or top cap mounted storage in a wall-start application or an off module fin panel, the wall-start option should be selected. A recessed frameless glass top cap connector (**TS7TFGR**) must also be ordered for this application.



A recessed frameless glass top cap connector (TS7TFGR) must be specified when a frameless glass screen is adjacent to a corner junction and the frameless glass top caps are located at a different (lower) height than the junction cap.

A recessed frameless glass top cap connector must be specified when recessed frameless glass is coming into an in-line change-of-height condition and the recessed frameless glass is located on the lower panel.

A recessed frameless glass top cap connector (TS7TFGR) must be specified when a frameless glass screen is adjacent to a boundary screen that is the same or taller height as the panel.

A recessed frameless glass top cap connector must be specified when recessed, frameless glass is adjacent to a utility pole.

Frameless Glass Screens with Recessed Attachment—Thin Trim, continued

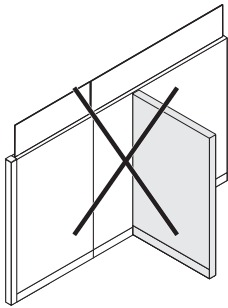

Recessed frameless glass cannot be used on a spine panel hosting the same height off-module connection. The off-module fin panel can use recessed frameless glass, but must have the wall-start option specified.

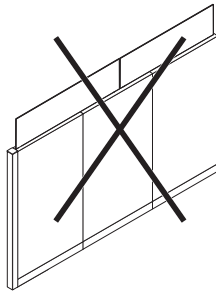

Both ends of the frameless glass screen must be at a junction. The frameless screen cannot end in the middle of a panel segment.

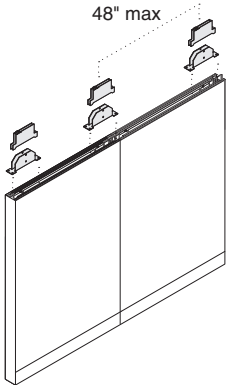

When omitting glass and using acrylic or 3 form material in place of glass additional support clamps may need to be ordered as service parts (**T522096SR** or **T522097SR**). Frameless glass kits 54" to 66" will also require additional support clamps to be ordered. When installing the support clamps the maximum allowed distance between the clamps is 48".

Field-Installed Glass Size Requirements

Style Number	Heights	Maximum Width	Thickness Range (min-max)
Standard			
TS7624TFGR	9 ⁵ / ₁₆ " 15 ¹ / ₂ " 21 ¹ / ₁₆ " and 27 ⁷ / ₈ "	23 ⁷ / ₈ "	.350-.4500"
TS7630TFGR	9 ⁵ / ₁₆ " 15 ¹ / ₂ " 21 ¹ / ₁₆ " and 27 ⁷ / ₈ "	29 ⁷ / ₈ "	.350-.4500"
TS7636TFGR	9 ⁵ / ₁₆ " 15 ¹ / ₂ " 21 ¹ / ₁₆ " and 27 ⁷ / ₈ "	35 ⁷ / ₈ "	.350-.4500"
TS7642TFGR	9 ⁵ / ₁₆ " 15 ¹ / ₂ " 21 ¹ / ₁₆ " and 27 ⁷ / ₈ "	41 ⁷ / ₈ "	.350-.4500"
TS7648TFGR	9 ⁵ / ₁₆ " 15 ¹ / ₂ " 21 ¹ / ₁₆ " and 27 ⁷ / ₈ "	47 ⁷ / ₈ "	.350-.4500"
TS7654TFGR	9 ⁵ / ₁₆ " 15 ¹ / ₂ " 21 ¹ / ₁₆ " and 27 ⁷ / ₈ "	53 ⁷ / ₈ "	.350-.4500"
TS7660TFGR	9 ⁵ / ₁₆ " 15 ¹ / ₂ " 21 ¹ / ₁₆ " and 27 ⁷ / ₈ "	59 ⁷ / ₈ "	.350-.4500"
TS7666TFGR	9 ⁵ / ₁₆ " 15 ¹ / ₂ " 21 ¹ / ₁₆ " and 27 ⁷ / ₈ "	65 ⁷ / ₈ "	.350-.4500"
TS7672TFGR	9 ⁵ / ₁₆ " 15 ¹ / ₂ " 21 ¹ / ₁₆ " and 27 ⁷ / ₈ "	71 ⁷ / ₈ "	.350-.4500"
TS7678TFGR	9 ⁵ / ₁₆ " 15 ¹ / ₂ " 21 ¹ / ₁₆ " and 27 ⁷ / ₈ "	77 ⁷ / ₈ "	.350-.4500"
TS7684TFGR	9 ⁵ / ₁₆ " 15 ¹ / ₂ " 21 ¹ / ₁₆ " and 27 ⁷ / ₈ "	83 ⁷ / ₈ "	.350-.4500"
TS7690TFGR	9 ⁵ / ₁₆ " 15 ¹ / ₂ " 21 ¹ / ₁₆ " and 27 ⁷ / ₈ "	89 ⁷ / ₈ "	.350-.4500"
TS7696TFGR	9 ⁵ / ₁₆ " 15 ¹ / ₂ " 21 ¹ / ₁₆ " and 27 ⁷ / ₈ "	95 ⁷ / ₈ "	.350-.4500"
TS71224TFGR	9 ⁵ / ₁₆ " 15 ¹ / ₂ " 21 ¹ / ₁₆ " and 27 ⁷ / ₈ "	23 ⁷ / ₈ "	.350-.4500"
TS71230TFGR	9 ⁵ / ₁₆ " 15 ¹ / ₂ " 21 ¹ / ₁₆ " and 27 ⁷ / ₈ "	29 ⁷ / ₈ "	.350-.4500"
TS71236TFGR	9 ⁵ / ₁₆ " 15 ¹ / ₂ " 21 ¹ / ₁₆ " and 27 ⁷ / ₈ "	35 ⁷ / ₈ "	.350-.4500"
TS71242TFGR	9 ⁵ / ₁₆ " 15 ¹ / ₂ " 21 ¹ / ₁₆ " and 27 ⁷ / ₈ "	41 ⁷ / ₈ "	.350-.4500"
TS71248TFGR	9 ⁵ / ₁₆ " 15 ¹ / ₂ " 21 ¹ / ₁₆ " and 27 ⁷ / ₈ "	47 ⁷ / ₈ "	.350-.4500"
TS71254TFGR	9 ⁵ / ₁₆ " 15 ¹ / ₂ " 21 ¹ / ₁₆ " and 27 ⁷ / ₈ "	53 ⁷ / ₈ "	.350-.4500"
TS71260TFGR	9 ⁵ / ₁₆ " 15 ¹ / ₂ " 21 ¹ / ₁₆ " and 27 ⁷ / ₈ "	59 ⁷ / ₈ "	.350-.4500"
TS71266TFGR	9 ⁵ / ₁₆ " 15 ¹ / ₂ " 21 ¹ / ₁₆ " and 27 ⁷ / ₈ "	65 ⁷ / ₈ "	.350-.4500"
TS71272TFGR	9 ⁵ / ₁₆ " 15 ¹ / ₂ " 21 ¹ / ₁₆ " and 27 ⁷ / ₈ "	71 ⁷ / ₈ "	.350-.4500"
TS71278TFGR	9 ⁵ / ₁₆ " 15 ¹ / ₂ " 21 ¹ / ₁₆ " and 27 ⁷ / ₈ "	77 ⁷ / ₈ "	.350-.4500"
TS71284TFGR	9 ⁵ / ₁₆ " 15 ¹ / ₂ " 21 ¹ / ₁₆ " and 27 ⁷ / ₈ "	83 ⁷ / ₈ "	.350-.4500"
TS71290TFGR	9 ⁵ / ₁₆ " 15 ¹ / ₂ " 21 ¹ / ₁₆ " and 27 ⁷ / ₈ "	89 ⁷ / ₈ "	.350-.4500"
TS71296TFGR	9 ⁵ / ₁₆ " 15 ¹ / ₂ " 21 ¹ / ₁₆ " and 27 ⁷ / ₈ "	95 ⁷ / ₈ "	.350-.4500"
TS71824TFGR	9 ⁵ / ₁₆ " 15 ¹ / ₂ " 21 ¹ / ₁₆ " and 27 ⁷ / ₈ "	23 ⁷ / ₈ "	.350-.4500"
TS71830TFGR	9 ⁵ / ₁₆ " 15 ¹ / ₂ " 21 ¹ / ₁₆ " and 27 ⁷ / ₈ "	29 ⁷ / ₈ "	.350-.4500"
TS71836TFGR	9 ⁵ / ₁₆ " 15 ¹ / ₂ " 21 ¹ / ₁₆ " and 27 ⁷ / ₈ "	35 ⁷ / ₈ "	.350-.4500"
TS71842TFGR	9 ⁵ / ₁₆ " 15 ¹ / ₂ " 21 ¹ / ₁₆ " and 27 ⁷ / ₈ "	41 ⁷ / ₈ "	.350-.4500"
TS71848TFGR	9 ⁵ / ₁₆ " 15 ¹ / ₂ " 21 ¹ / ₁₆ " and 27 ⁷ / ₈ "	47 ⁷ / ₈ "	.350-.4500"
TS71854TFGR	9 ⁵ / ₁₆ " 15 ¹ / ₂ " 21 ¹ / ₁₆ " and 27 ⁷ / ₈ "	53 ⁷ / ₈ "	.350-.4500"
TS71860TFGR	9 ⁵ / ₁₆ " 15 ¹ / ₂ " 21 ¹ / ₁₆ " and 27 ⁷ / ₈ "	59 ⁷ / ₈ "	.350-.4500"
TS71866TFGR	9 ⁵ / ₁₆ " 15 ¹ / ₂ " 21 ¹ / ₁₆ " and 27 ⁷ / ₈ "	65 ⁷ / ₈ "	.350-.4500"
TS71872TFGR	9 ⁵ / ₁₆ " 15 ¹ / ₂ " 21 ¹ / ₁₆ " and 27 ⁷ / ₈ "	71 ⁷ / ₈ "	.350-.4500"
TS71878TFGR	9 ⁵ / ₁₆ " 15 ¹ / ₂ " 21 ¹ / ₁₆ " and 27 ⁷ / ₈ "	77 ⁷ / ₈ "	.350-.4500"
TS71884TFGR	9 ⁵ / ₁₆ " 15 ¹ / ₂ " 21 ¹ / ₁₆ " and 27 ⁷ / ₈ "	83 ⁷ / ₈ "	.350-.4500"
TS71890TFGR	9 ⁵ / ₁₆ " 15 ¹ / ₂ " 21 ¹ / ₁₆ " and 27 ⁷ / ₈ "	89 ⁷ / ₈ "	.350-.4500"
TS71896TFGR	9 ⁵ / ₁₆ " 15 ¹ / ₂ " 21 ¹ / ₁₆ " and 27 ⁷ / ₈ "	95 ⁷ / ₈ "	.350-.4500"

Field-Installed Glass Size Requirements

Style Number	Heights	Maximum Width	Thickness Range (min-max)
Change-of-Height—one end			
TS7624TFGR	9 ⁵ / ₁₆ " 15 ¹ / ₂ " 21 ¹¹ / ₁₆ " and 27 ⁷ / ₈ "	23 ⁷ / ₁₆ "	.350-.4500"
TS7630TFGR	9 ⁵ / ₁₆ " 15 ¹ / ₂ " 21 ¹¹ / ₁₆ " and 27 ⁷ / ₈ "	29 ⁷ / ₁₆ "	.350-.4500"
TS7636TFGR	9 ⁵ / ₁₆ " 15 ¹ / ₂ " 21 ¹¹ / ₁₆ " and 27 ⁷ / ₈ "	35 ⁷ / ₁₆ "	.350-.4500"
TS7642TFGR	9 ⁵ / ₁₆ " 15 ¹ / ₂ " 21 ¹¹ / ₁₆ " and 27 ⁷ / ₈ "	41 ⁷ / ₁₆ "	.350-.4500"
TS7648TFGR	9 ⁵ / ₁₆ " 15 ¹ / ₂ " 21 ¹¹ / ₁₆ " and 27 ⁷ / ₈ "	47 ⁷ / ₁₆ "	.350-.4500"
TS7654TFGR	9 ⁵ / ₁₆ " 15 ¹ / ₂ " 21 ¹¹ / ₁₆ " and 27 ⁷ / ₈ "	53 ⁷ / ₁₆ "	.350-.4500"
TS7660TFGR	9 ⁵ / ₁₆ " 15 ¹ / ₂ " 21 ¹¹ / ₁₆ " and 27 ⁷ / ₈ "	59 ⁷ / ₁₆ "	.350-.4500"
TS7666TFGR	9 ⁵ / ₁₆ " 15 ¹ / ₂ " 21 ¹¹ / ₁₆ " and 27 ⁷ / ₈ "	65 ⁷ / ₁₆ "	.350-.4500"
TS7672TFGR	9 ⁵ / ₁₆ " 15 ¹ / ₂ " 21 ¹¹ / ₁₆ " and 27 ⁷ / ₈ "	71 ⁷ / ₁₆ "	.350-.4500"
TS7678TFGR	9 ⁵ / ₁₆ " 15 ¹ / ₂ " 21 ¹¹ / ₁₆ " and 27 ⁷ / ₈ "	77 ⁷ / ₁₆ "	.350-.4500"
TS7684TFGR	9 ⁵ / ₁₆ " 15 ¹ / ₂ " 21 ¹¹ / ₁₆ " and 27 ⁷ / ₈ "	83 ⁷ / ₁₆ "	.350-.4500"
TS7690TFGR	9 ⁵ / ₁₆ " 15 ¹ / ₂ " 21 ¹¹ / ₁₆ " and 27 ⁷ / ₈ "	89 ⁷ / ₁₆ "	.350-.4500"
TS7696TFGR	9 ⁵ / ₁₆ " 15 ¹ / ₂ " 21 ¹¹ / ₁₆ " and 27 ⁷ / ₈ "	95 ⁷ / ₁₆ "	.350-.4500"
TS71224TFGR	9 ⁵ / ₁₆ " 15 ¹ / ₂ " 21 ¹¹ / ₁₆ " and 27 ⁷ / ₈ "	23 ⁷ / ₁₆ "	.350-.4500"
TS71230TFGR	9 ⁵ / ₁₆ " 15 ¹ / ₂ " 21 ¹¹ / ₁₆ " and 27 ⁷ / ₈ "	29 ⁷ / ₁₆ "	.350-.4500"
TS71236TFGR	9 ⁵ / ₁₆ " 15 ¹ / ₂ " 21 ¹¹ / ₁₆ " and 27 ⁷ / ₈ "	35 ⁷ / ₁₆ "	.350-.4500"
TS71242TFGR	9 ⁵ / ₁₆ " 15 ¹ / ₂ " 21 ¹¹ / ₁₆ " and 27 ⁷ / ₈ "	41 ⁷ / ₁₆ "	.350-.4500"
TS71248TFGR	9 ⁵ / ₁₆ " 15 ¹ / ₂ " 21 ¹¹ / ₁₆ " and 27 ⁷ / ₈ "	47 ⁷ / ₁₆ "	.350-.4500"
TS71254TFGR	9 ⁵ / ₁₆ " 15 ¹ / ₂ " 21 ¹¹ / ₁₆ " and 27 ⁷ / ₈ "	53 ⁷ / ₁₆ "	.350-.4500"
TS71260TFGR	9 ⁵ / ₁₆ " 15 ¹ / ₂ " 21 ¹¹ / ₁₆ " and 27 ⁷ / ₈ "	59 ⁷ / ₁₆ "	.350-.4500"
TS71266TFGR	9 ⁵ / ₁₆ " 15 ¹ / ₂ " 21 ¹¹ / ₁₆ " and 27 ⁷ / ₈ "	65 ⁷ / ₁₆ "	.350-.4500"
TS71272TFGR	9 ⁵ / ₁₆ " 15 ¹ / ₂ " 21 ¹¹ / ₁₆ " and 27 ⁷ / ₈ "	71 ⁷ / ₁₆ "	.350-.4500"
TS71278TFGR	9 ⁵ / ₁₆ " 15 ¹ / ₂ " 21 ¹¹ / ₁₆ " and 27 ⁷ / ₈ "	77 ⁷ / ₁₆ "	.350-.4500"
TS71284TFGR	9 ⁵ / ₁₆ " 15 ¹ / ₂ " 21 ¹¹ / ₁₆ " and 27 ⁷ / ₈ "	83 ⁷ / ₁₆ "	.350-.4500"
TS71290TFGR	9 ⁵ / ₁₆ " 15 ¹ / ₂ " 21 ¹¹ / ₁₆ " and 27 ⁷ / ₈ "	89 ⁷ / ₁₆ "	.350-.4500"
TS71296TFGR	9 ⁵ / ₁₆ " 15 ¹ / ₂ " 21 ¹¹ / ₁₆ " and 27 ⁷ / ₈ "	95 ⁷ / ₁₆ "	.350-.4500"
TS71824TFGR	9 ⁵ / ₁₆ " 15 ¹ / ₂ " 21 ¹¹ / ₁₆ " and 27 ⁷ / ₈ "	23 ⁷ / ₁₆ "	.350-.4500"
TS71830TFGR	9 ⁵ / ₁₆ " 15 ¹ / ₂ " 21 ¹¹ / ₁₆ " and 27 ⁷ / ₈ "	29 ⁷ / ₁₆ "	.350-.4500"
TS71836TFGR	9 ⁵ / ₁₆ " 15 ¹ / ₂ " 21 ¹¹ / ₁₆ " and 27 ⁷ / ₈ "	35 ⁷ / ₁₆ "	.350-.4500"
TS71842TFGR	9 ⁵ / ₁₆ " 15 ¹ / ₂ " 21 ¹¹ / ₁₆ " and 27 ⁷ / ₈ "	41 ⁷ / ₁₆ "	.350-.4500"
TS71848TFGR	9 ⁵ / ₁₆ " 15 ¹ / ₂ " 21 ¹¹ / ₁₆ " and 27 ⁷ / ₈ "	47 ⁷ / ₁₆ "	.350-.4500"
TS71854TFGR	9 ⁵ / ₁₆ " 15 ¹ / ₂ " 21 ¹¹ / ₁₆ " and 27 ⁷ / ₈ "	53 ⁷ / ₁₆ "	.350-.4500"
TS71860TFGR	9 ⁵ / ₁₆ " 15 ¹ / ₂ " 21 ¹¹ / ₁₆ " and 27 ⁷ / ₈ "	59 ⁷ / ₁₆ "	.350-.4500"
TS71866TFGR	9 ⁵ / ₁₆ " 15 ¹ / ₂ " 21 ¹¹ / ₁₆ " and 27 ⁷ / ₈ "	65 ⁷ / ₁₆ "	.350-.4500"
TS71872TFGR	9 ⁵ / ₁₆ " 15 ¹ / ₂ " 21 ¹¹ / ₁₆ " and 27 ⁷ / ₈ "	71 ⁷ / ₁₆ "	.350-.4500"
TS71878TFGR	9 ⁵ / ₁₆ " 15 ¹ / ₂ " 21 ¹¹ / ₁₆ " and 27 ⁷ / ₈ "	77 ⁷ / ₁₆ "	.350-.4500"
TS71884TFGR	9 ⁵ / ₁₆ " 15 ¹ / ₂ " 21 ¹¹ / ₁₆ " and 27 ⁷ / ₈ "	83 ⁷ / ₁₆ "	.350-.4500"
TS71890TFGR	9 ⁵ / ₁₆ " 15 ¹ / ₂ " 21 ¹¹ / ₁₆ " and 27 ⁷ / ₈ "	89 ⁷ / ₁₆ "	.350-.4500"
TS71896TFGR	9 ⁵ / ₁₆ " 15 ¹ / ₂ " 21 ¹¹ / ₁₆ " and 27 ⁷ / ₈ "	95 ⁷ / ₁₆ "	.350-.4500"

Frameless Glass Screens with Clip Attachment—Thin Trim

Frameless glass screen with clip attachment

can be added to the top of a panel to help define space and provide some privacy while still providing access to natural light and promoting communication between adjacent workers.

► Specifying, page 368

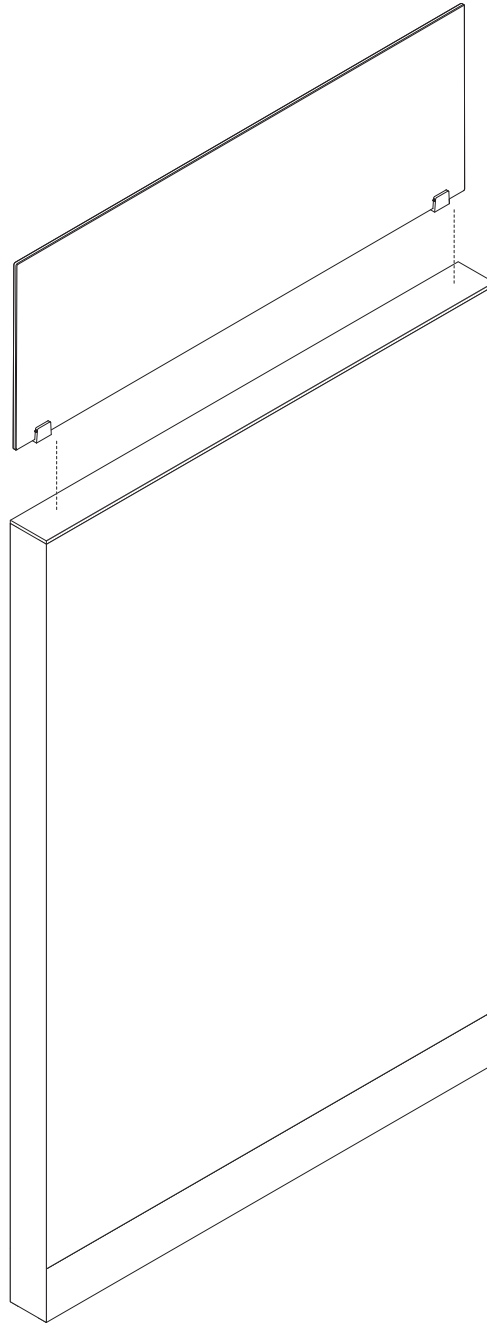

Product Details

Frameless glass screen with clip attachment

is secured to horizontal connecting bar by supports below the top cap and brackets above the top cap. Two brackets are used above the top cap to attach the glass to the panel on 24"–60"W panels. Three brackets are used on panels 78" and wider.

Frameless glass screens with clip attachment

can be used on panels with thin profile trim.

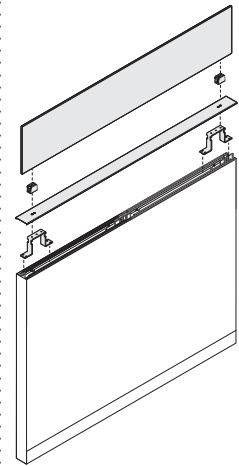

Frameless glass kit

includes glass screen, brackets, supports, and top cap with holes to accommodate brackets.

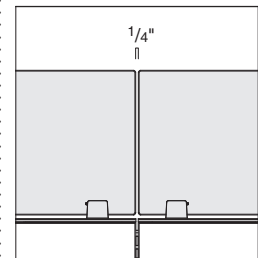

Gap between adjacent glass screens is $\frac{1}{4}$ ".

Actual Dimensions

Glass Width – standard: 23 $\frac{3}{4}$ ", 29 $\frac{3}{4}$ ", 35 $\frac{3}{4}$ ", 41 $\frac{3}{4}$ ", 47 $\frac{3}{4}$ ", 59 $\frac{3}{4}$ ", 71 $\frac{3}{4}$ ", 77 $\frac{3}{4}$ ", 83 $\frac{3}{4}$ ", 89 $\frac{3}{4}$ ", and 95 $\frac{3}{4}$ "

Glass Width – change-of-height one end thin trim: 23 $\frac{1}{4}$ ", 29 $\frac{1}{4}$ ", 35 $\frac{1}{4}$ ", 41 $\frac{1}{4}$ ", 47 $\frac{1}{4}$ ", 59 $\frac{1}{4}$ ", 71 $\frac{1}{4}$ ", 77 $\frac{1}{4}$ ", 83 $\frac{1}{4}$ ", 89 $\frac{1}{4}$ ", and 95 $\frac{1}{4}$ "

Glass Height: 11 $\frac{3}{4}$ "

Glass Thickness: $\frac{3}{8}$ "

Surface Materials

Glass

- 6500 Clear Glass
- 6530 Frosted Glass

Tip: Frosted glass for clip attachment frameless glass is a double opaque glass construction. There may be variation in color, texture, and finish between the sample of 6530 Frosted Glass and the actual product.

Brackets

- Paint

Top cap

- Paint
- Wood veneer

Application Topics

Frameless glass screen

can be placed on the top of a panel only. Top beam in the panel must be located in the top position of the frame in order to support frameless glass. Frameless glass can be used on base panels or stacking panels.

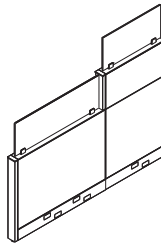

Change-of-height top cap option is available to allow for positioning of glass next to change-of-height trim on one side only. Glass is shortened and top cap provided supports change-of-height on one end only.

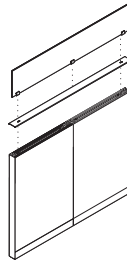

90" and 96" wide frameless glass screen kits include three brackets. Two brackets attach to supports below the top cap. The third bracket attaches only to the top cap through a hole that is drilled in the top cap by the installer on site.

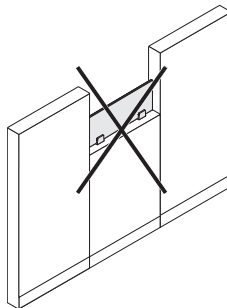

Frameless glass screen will not fit between two change-of-height trims.

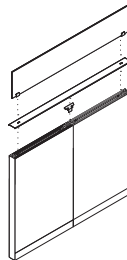

Frameless glass kit is available without glass screen to accommodate customer's own glass. See chart of field installed glass size requirements for specific dimensions required for glass to fit in frameless glass brackets. Steelcase recommends the use of safety glass meeting ANSI Z97.1 for field installed glass. Check with your local building authority for requirements in your area.

In-line spanning top cap lightseal must be specified separately when used in this application. Spanning top cap lightseal attaches to underside of top cap to fill space between skin lightseals. Specify one for each in-line junction the frameless glass screen spans.

A template tool is available from Service Parts (**T511082SR**) to assist in locating where holes are to be drilled on the beam of an existing panel to allow supports to be attached. This only applies to beams produced prior to September 2009. Beams produced after this date include holes to allow frameless glass supports to be attached.

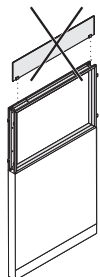

Frameless glass screen cannot be used when a window is located in the top position of the panel.

Frameless glass screen

cannot be added to a panel segment with a 6" stacker.

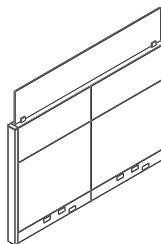

A single frameless glass screen can span over two or more panels.

Field-Installed Glass Size Requirements

Style Number	Maximum Height	Maximum Width	Thickness Range (min-max)
Standard			
TS71224TFG	11 ³ / ₄ "	23 ³ / ₄ "	.350-.400"
TS71230TFG	11 ³ / ₄ "	29 ³ / ₄ "	.350-.400"
TS71236TFG	11 ³ / ₄ "	35 ³ / ₄ "	.350-.400"
TS71242TFG	11 ³ / ₄ "	41 ³ / ₄ "	.350-.400"
TS71248TFG	11 ³ / ₄ "	47 ³ / ₄ "	.350-.400"
TS71260TFG	11 ³ / ₄ "	59 ³ / ₄ "	.350-.400"
TS71272TFG	11 ³ / ₄ "	71 ³ / ₄ "	.350-.400"
TS71278TFG	11 ³ / ₄ "	77 ³ / ₄ "	.350-.400"
TS71284TFG	11 ³ / ₄ "	83 ³ / ₄ "	.350-.400"
TS71290TFG	11 ³ / ₄ "	89 ³ / ₄ "	.350-.400"
TS71296TFG	11 ³ / ₄ "	95 ³ / ₄ "	.350-.400"
Change-of-Height – one end			
TS71224TFG	11 ³ / ₄ "	23 ¹ / ₄ "	.350-.400"
TS71230TFG	11 ³ / ₄ "	29 ¹ / ₄ "	.350-.400"
TS71236TFG	11 ³ / ₄ "	35 ¹ / ₄ "	.350-.400"
TS71242TFG	11 ³ / ₄ "	41 ¹ / ₄ "	.350-.400"
TS71248TFG	11 ³ / ₄ "	47 ¹ / ₄ "	.350-.400"
TS71260TFG	11 ³ / ₄ "	59 ¹ / ₄ "	.350-.400"
TS71272TFG	11 ³ / ₄ "	71 ¹ / ₄ "	.350-.400"
TS71278TFG	11 ³ / ₄ "	77 ¹ / ₄ "	.350-.400"
TS71284TFG	11 ³ / ₄ "	83 ¹ / ₄ "	.350-.400"
TS71290TFG	11 ³ / ₄ "	89 ¹ / ₄ "	.350-.400"
TS71296TFG	11 ³ / ₄ "	95 ¹ / ₄ "	.350-.400"

Tip: Field installed glass should always be tempered. Laminated glass must not be used.

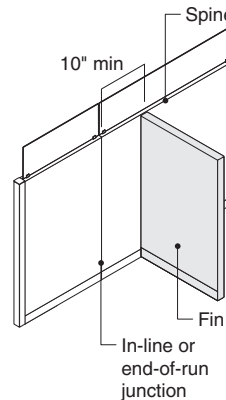

When using frameless glass on a spine panel with a same height off-module panel connections, the off-module cannot connect within 10" of an end-of-run or in-line junction connection.

Universal Screens with Answer Thin Trim Top Cap

Universal screens provide a tackable boundary element along the Answer panel. They are available in two heights to accommodate varying levels of privacy.
 ▶ Specifying, page 370

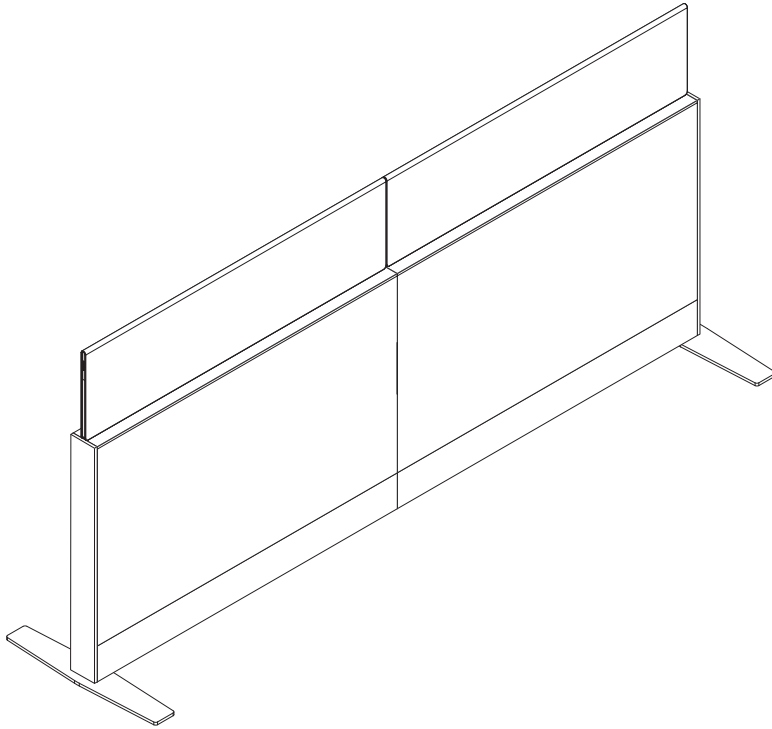

Actual Dimensions

Height	13½" or 19½"
Width	24", 30", 36", 42", 48", 54", 60", 66", 72", 78", 84", 90", or 96"

Tip: 13½"H screen aligns with a 42" overall height from the floor, when installed to a 30"H panel. 19½" screen aligns with a 48" overall height from the floor, when installed to a 30"H panel.

Product Details

Universal screens with Answer top cap can only be used with thin profile trim.

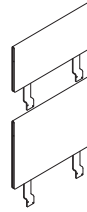

Universal screens are tackable and available in 13½"H and 19½"H, and have widths from 24"W to 96"W.

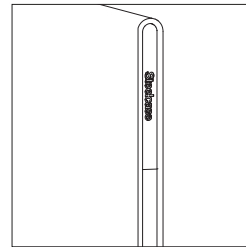

The edge of the screen is comprised of two different materials. The upper segment is merle plastic. The lower portion is PET which can be specified in medium heather grey to provide contrast or dark heather grey for a uniform visual.

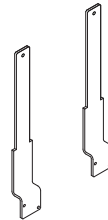

Brackets are included with screens. Two brackets are used on all screens.

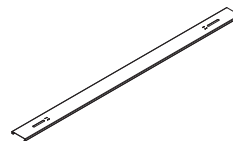

Universal screens include a thin trim top cap with slots for the screen brackets.

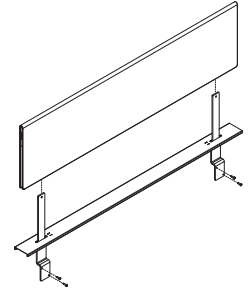

Universal screen and top cap slide onto brackets.

Screen brackets install on horizontal connecting bar prior to installation of skins and top cap.

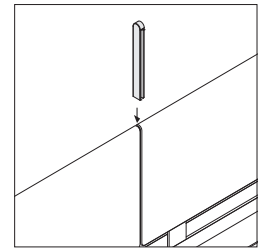

When Universal screens are placed directly adjacent to each other in-line, a small aligner can be placed in between the screens at the top to connect them for planar alignment. Aligners are ordered separately in packages of 10.

Application Topics

Universal screen can be placed on the top of a panel only. Top bar in the panel must be located in the top position of the frame in order to support Universal screens. Universal screens can be used on base panels or stacking panels.

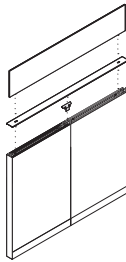

The Universal screen cannot be added to a panel segment with a 6" stacker.

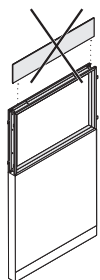

Universal screens cannot be used when a window is located in the top position of the panel.

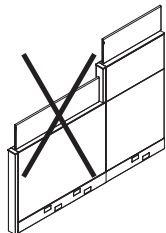

Universal screens on Answer panel cannot be added to the lower panel segment of an in-line change-of-height condition.

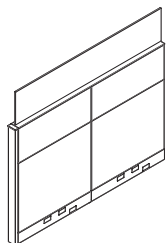

A single Universal screen can span over two or more in-line panels up to 96".

Universal screens for Answer panel cannot span a corner junction.

Surface Materials

Screen

- Fabric
- ▶ See *Surface Materials*, page 667.

Brackets

- 7360 Merle

Edge (lower segment)

- P630 Medium Heather Grey PET
- P631 Dark Heather Grey PET

Top cap

- Paint
- ▶ See *Surface Materials*, page 667.

In-line spanning top cap lightseal must be specified separately when used in this application. Spanning top cap lightseal attaches to underside of top cap to fill space between skin lightseals. Specify one for each in-line junction the Universal screen spans.

Universal screens can be used on a spine panel hosting the same height off-module connection. The off-module panel cannot connect to the spine where the Universal screen bracket connects to the horizontal bar.

Sarto Fence Screens with Answer Thin Trim Top Cap

Sarto screens provide a light scale tackable boundary element along the Answer panel. They are available in two heights to accommodate varying levels of privacy.

► Specifying, page 370

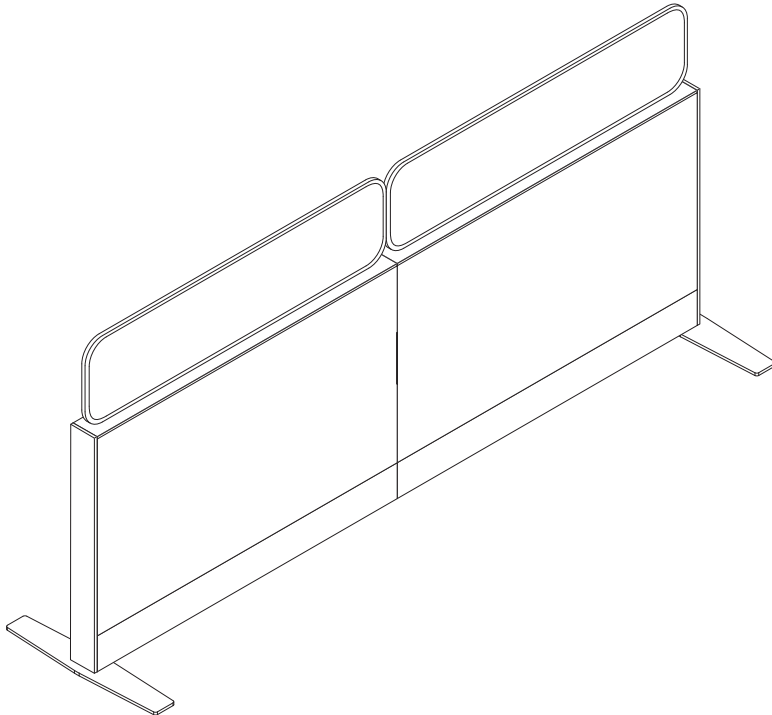

Actual Dimensions

Screen Height	12½" or 18½"
Width	24", 30", 36", 42", 48", 54", 60", 66", 72", 78", 84", 90", or 96"

Tip: 13½"H screen aligns with a 42" overall height from the floor, when installed to a 30"H panel. 19½"H screen aligns with a 48" overall height from the floor, when installed to a 30"H panel.

Product Details

Sarto screens with Answer top cap can only be used with thin profile trim.



Sarto screens are tackable. They are available in two heights, 13½"H and 19½"H, and have widths ranging from 24"W to 96"W.

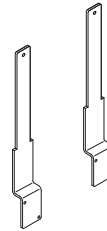

Brackets and hard stops are included with screens. Two brackets are used on screens 54"W and smaller. Three brackets are used on screens 60"W and larger.

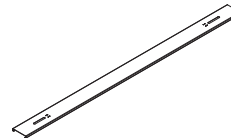

Universal screens include a thin trim top cap with slots for the screen brackets

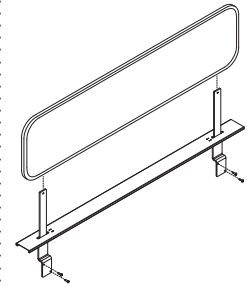

Sarto screen slides onto brackets after top cap and hard stops are installed on the brackets.

Screen brackets install on horizontal connecting bar prior to installation of skins and top cap.

Application Topics

Sarto screen can be placed on the top of a panel only. Top bar in the panel must be located in the top position of the frame in order to support Sarto screens. Sarto screens can be used on base panels or stacking panels.

The Sarto screen cannot be added to a panel segment with a 6" stacker.

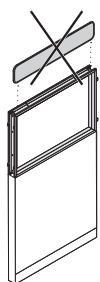

Sarto screens cannot be used when a window is located in the top position of the panel.

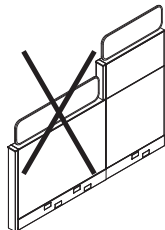

Sarto screens on Answer panel cannot be added to the lower panel segment of an in-line change-of-height condition.

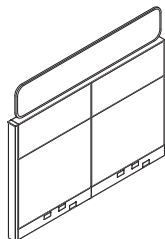

A single Sarto screen can span over two or more in-line panels up to 96".

A single Sarto screen that is 60"W or wider cannot span two panel sections of equal width. The middle bracket of the Sarto screen will interfere with the inline junction.

Sarto screens for Answer panel cannot span a corner junction.

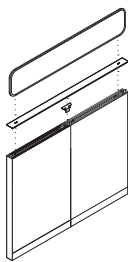

In-line spanning top cap lightseal must be specified separately when used in this application. Spanning top cap lightseal attaches to underside of top cap to fill space between skin lightseals. Specify one for each in-line junction the Sarto screen spans.

Sarto screens can be used on a spine panel hosting the same height off-module connection. The off module panel cannot connect to the spine where the Universal screen bracket connects to the horizontal bar.

Surface Materials

Screen

- Fabric
- ▶ See *Surface Materials*, page 667.

Brackets

- 7360 Merle

Top Cap

- Paint
- ▶ See *Surface Materials*, page 667.

Top Cap Mounted Storage

Top cap mounted storage allows for existing Duo, Elective Elements, and Currency storage to be mounted on top of Answer panels.
 ▶ Specifying, page 372

Duo, Currency, and Elective Elements storage can be mounted on top of Answer panels with thin trim.

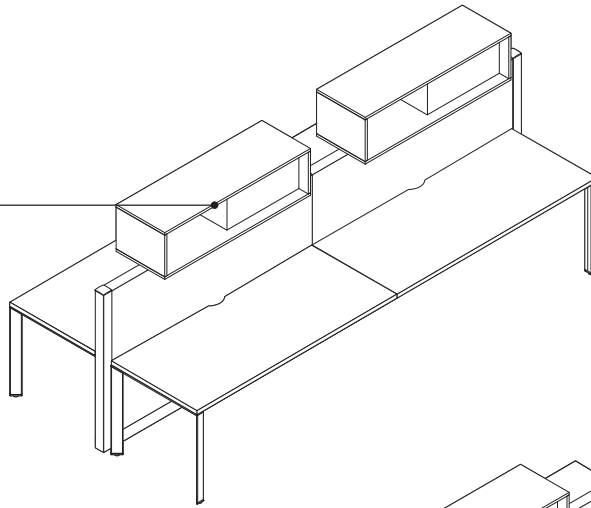

Top cap mounted storage can be mounted both on- and off-module.

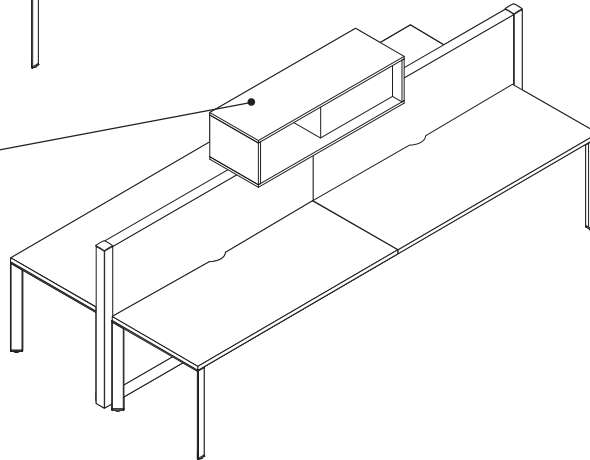

Top cap mounted storage can be specified for both center-mounted (shared) and aisleway applications.

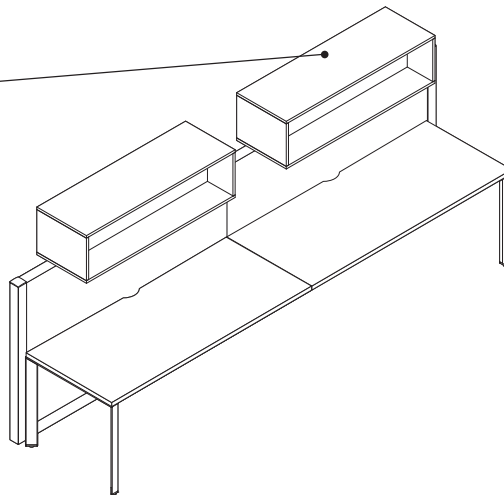

Product Details

Top cap mounted storage utilizes existing Duo, Currency, and Elective Elements storage and secures it to the horizontal connecting bar using supports below the top cap. Storage units can be mounted both centered (shared) or in an aisleway condition (personal). There are unique brackets for each application. Two brackets are used below the top cap to attach storage units that are center mounted (all sizes) or in aisleway applications where the storage is between 30"W and 48"W. Three brackets are used in aisleway applications where the storage units are 54"W to 72"W.

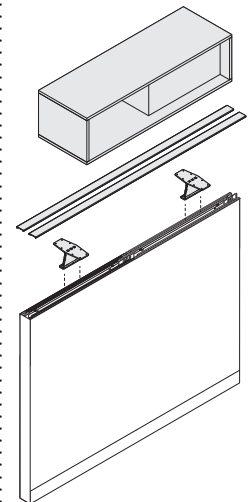

The top cap mounted storage solution is comprised of three elements specified separately:

- standard Duo, Currency, or Elective Elements storage.
 ▶ See complete listing for compatible storage, page 76.
- top cap mounted storage bracket.
- top cap and aligner packages.

Top cap mounted storage can be used on panels with thin trim only.

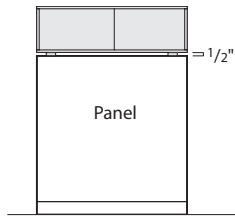

Front View

When installed, there is a 1/2" gap between the top cap and the bottom of the storage unit.

When mounting **Selective Elements personal storage**, a proud back should be specified. While inset is also an option, proud will provide you with a cleaner aesthetic.

The maximum storage unit length that can be used in a top cap mounted application is 72". Storage wider than 72" cannot be top cap mounted.

Application Topics

Top cap mounted storage can be placed on top of a thin trim panel only. It can be used with both painted and wood trims. The top beam in the panel must be located in the top position of the frame in order to support top cap mounted storage.

Top cap mounted storage can only be used on base panels. It cannot be used on stacking panels.

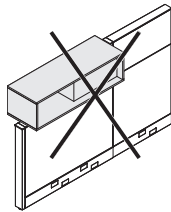

Top cap mounted storage can not be used in an in-line change-of-height condition when the storage is located on the lower panel and matches the panel width. It can be used if the storage width is smaller than the panel width.

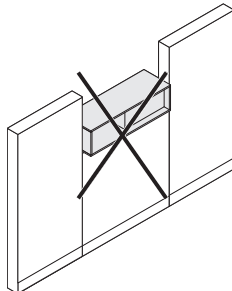

Top cap mounted storage will not fit between two change-of-height trims if the storage is the same width as the panel it is mounted to. Storage must be narrower width than panel in this application.

Top cap and aligner packages are ordered together as one style number. The aligner package includes two end-of-run aligners, two in-line aligners, and one pair of recessed-to-recessed aligners.



In certain application conditions a **top cap connector aligner (TS7TFGR)** will also need to be specified. These include when storage or frameless glass is used on-module next to a wall-start junction, adjacent to a boundary screen, on an off-module panel, or in a corner change-of-height where the storage is used on the lower panel.

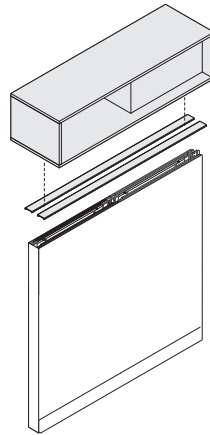

Top cap mounted storage has the ability to be mounted on panel module, or in off-module conditions. When the storage matches the panel width, the standard top caps from the horizontal frame package can be omitted as the top cap mounted storage top caps will be sufficient.

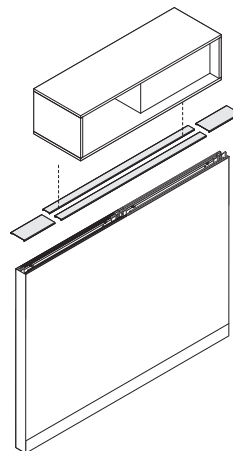

When the top cap mounted storage does not match the panel width, standard top caps will need to remain specified with the horizontal frame packages. Center mounted top caps will be used under the storage. The standard top caps will be used to finish off the top of the panel where there is not storage present. The standard top caps will need to be field cut to size.

Top cap mounted storage has the ability to span both in-line and corner junctions.

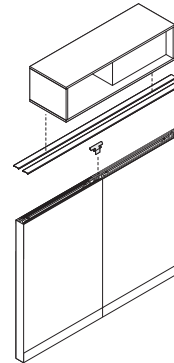

In-line spanning top cap lightseal must be specified separately when used in this application. Spanning top cap light seal attaches to the underside of the top cap to fill space between skin lightseals. Specify one for each in-line junction the top cap mounted storage spans over.

End-of-run and junction cap aligners manufactured after November 2012 will have features to accommodate top cap mounted storage top caps. Aligners manufactured before November 2012 will not be able to accommodate top cap mounted storage top caps and new aligners will be needed.

Duo, Currency, and Elective Elements storage can be top cap mounted on Answer panels up to 48"H.

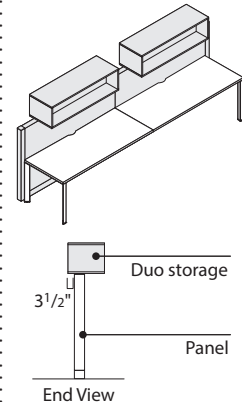

When top cap mounted storage is used in an aisleway application the back of the storage unit will overhang the back of the panel 3 1/2".

Connections

Both center and aisleway conditions can accept storage units up to 72"W. Center mounted conditions can accept storage up to 25"D. Aisleway mounted applications can accept storage up to 17"D.

Top cap mounted brackets should be mounted within 10" from the end of the storage unit. When possible, use the predrilled holes in the Answer horizontal bar. In some applications and in aisleway applications where the storage is larger than 48"W, additional holes will need to be drilled into the beam.

Both center and aisleway mounted storage units cannot overhang an end of run or corner junction more than 3 1/2" due to ADA guidelines.

Surface Materials

Brackets

- Paint

Top cap

- Paint
- Wood veneer

Top Cap Mounted Storage, continued

Universal tie plates (TS7TIEPLATE) can be used to help align two storage units mounted in-line with no gap between them. Two tie plates should be used, one near each edge. When using with Duo, Currency, or Elective Elements storage, the hardware shipped with the plates can be used.

Surface Materials

Brackets

- Paint

Top cap

- Paint
- Wood veneer

Duo, Elective Elements, and Currency Storage Units That Can Be Used with Answer Top Cap Mounting Brackets

Duo

Duo Shared Tall Storage

BDTD54

BDTD66

Duo Individual Tall Storage

BDTS54

BDTS66

Elective Elements

Tip: Same Elective Elements storage units have different back options including inset, proud, or tackable.

Elective Elements Single-High Overhead with Hinged Door

E6OS153015H

E6OS153615H

E6OS154215H

E6OS154815H

E6OS155415H

E6OS156015H

E6OS156615H

E6OS157215H

E6OS183015H

E6OS183615H

E6OS184215H

E6OS184815H

E6OS185415H

E6OS186015H

E6OS186615H

E6OS187215H

Elective Elements, continued

Elective Elements Single-High Overhead with Sliding Door

E6OS153615S

E6OS154215S

E6OS154815S

E6OS155415S

E6OS156015S

E6OS156615S

E6OS157215S

E6OS183615S

E6OS184215S

E6OS184815S

E6OS185415S

E6OS186015S

E6OS186615S

E6OS187215S

Elective Elements Single-High Overhead Open

E6OS153015P

E6OS153615P

E6OS154215P

E6OS154815P

E6OS155415P

E6OS156015P

E6OS156615P

E6OS157215P

E6OS173015P

E6OS173615P

E6OS174215P

E6OS174815P

E6OS175415P

E6OS176015P

E6OS176615P

E6OS177215P

Elective Elements, continued

Elective Elements Personal for FrameOne

E6OA153015P

E6OA153615P

E6OA154215P

E6OA154815P

E6OA156015P

E6OA156615P

E6OA157215P

Elective Elements Shared for FrameOne

E6OF153015P

E6OF153615P

E6OF154215P

E6OF154815P

E6OF156015P

E6OF156615P

E6OF157215P

Elective Elements Personal for FrameOne with Sliding Door

E6OA153615S

E6OA154215S

E6OA154815S

E6OA156015S

E6OA156615S

E6OA157215S

Duo, Elective Elements, and Currency Storage Units That Can Be Used with Answer Top Cap Mounting Brackets

Elective Elements, continued

Elective Elements Shared for FrameOne with Sliding Door

- E6OF153615S
- E6OF154215S
- E6OF154815S
- E6OF156015S
- E6OF156615S
- E6OF157215S

Elective Elements Organizer

- E6OO15307
- E6OO15367
- E6OO15427
- E6OO15487
- E6OO15547
- E6OO15607
- E6OO15667
- E6OO15727
- E6OO17307
- E6OO17367
- E6OO17427
- E6OO17487
- E6OO17547
- E6OO17607
- E6OO17667
- E6OO17727

Elective Elements, continued

Elective Elements Personal Organizer for FrameOne

- E6SA15307
- E6SA15367
- E6SA15427
- E6SA15487
- E6SA15607
- E6SA15667
- E6SA15727

Elective Elements Shared Organizer for FrameOne

- E6SF15307
- E6SF15367
- E6SF15427
- E6SF15487
- E6SF15607
- E6SF15667
- E6SF15727

Currency

Currency Overhead

- CROH

Currency Organizers

- CROR

Panel Packages—Thin Trim

Panel packages include two monolithic fabric skins and a horizontal frame package. Answer panels always share a junction with adjacent panels. Order the style of junction you need separately.

► Specifying, page 374

Top cap snaps onto top of panel skins. Top caps are available in Thin trim. Change-of-height top caps, wood veneer top caps, and omit top caps are also available as options on Thin trim.

Power can be field-installed every 12" vertically using powerkits.

Junctions, ordered separately, are always shared by adjacent panels. They are available for in-line, L, T, V, X, Y, and end-of-run configurations. Wall-start junctions and off-module connector brackets are also available.

Optional cable tray can be used for additional support of cables. Additional cable trays can be installed and arranged at various heights within the frame for communications access and cable routing.

Skins attach to frame without tools and can be removed and repositioned easily. They are not dedicated to a specific location.

Power and communication can be accessed by cutting skin in the field. Templates for cutting both receptacle and communication cutouts are available from Service Parts (T500940SR). Filler to close unwanted cutout in a skin is available from Service Parts (**TS7STFSR**).

Powerkits include powerblocks attached to a supporting power tray. ► Page 176

Base trim or open base trim styles are available on panels with Thin trim as standard.

Base cover has knockouts to accommodate power and communication terminations. Top knockout is for power, bottom knockout is for communication. Filler to close unwanted knockouts is available from Service Parts (**TS7BTFSR**).

Horizontal connecting bars lock into the vertical junctions at the top and the bottom location to provide structural stability for the panels.

Optional base cable tray can be used to support lay-in of cables.

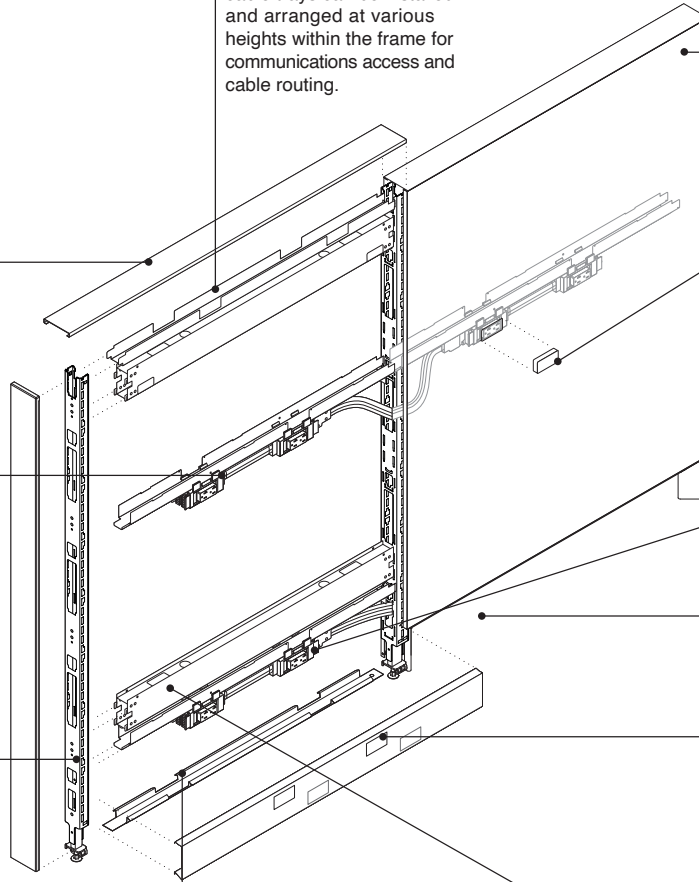

Actual Dimensions

Depth	3"
Width	17 ⁵ / ₆₄ ", 23 ⁵ / ₆₄ ", 29 ⁵ / ₆₄ ", 35 ⁵ / ₆₄ ", 41 ⁵ / ₆₄ ", 47 ⁵ / ₆₄ ", 59 ⁵ / ₆₄ ", and 71 ⁵ / ₆₄ "
Height	41 ³ / ₄ ", 47 ¹⁵ / ₁₆ ", 54 ³⁵ / ₆₄ ", and 66 ¹⁵ / ₃₂ "

Order panel packages to create common panel configurations quickly and easily.

1. Specify a panel package of the width and height you need in thin top caps.

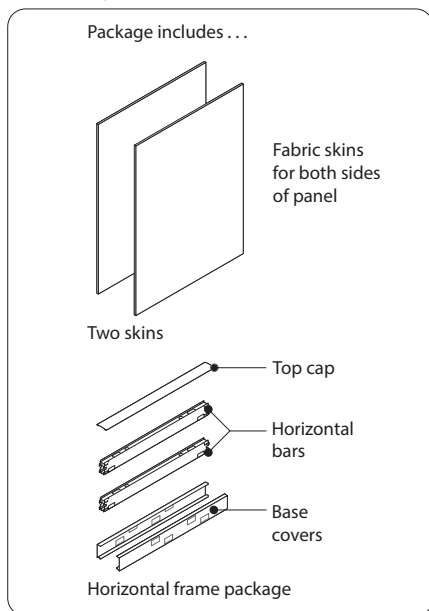

Note: Cable trays and base cable trays are optional.

2. Order vertical junctions to complete panel packages and to join panels in in-line, L, T, V, X, and Y configurations and to terminate an end-of-run. Junctions are available with trim.

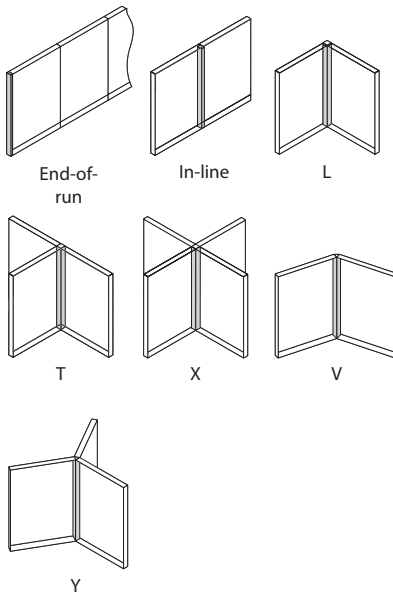

3. Specify powerkits where you will need power. You can specify a powerkit as an option on the panel package, or you can order powerkits separately.

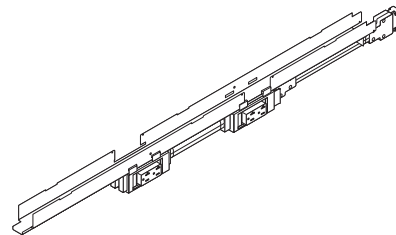

Answer Boundary Screens

Boundary screens provide light scale space division and privacy for a variety of worksettings.

Answer boundary screens attach to the Answer panel at the end-of-run as an alternative to a panel, when power and hang-on components are not required.
 ▶ Specifying, pages 376 - 392

Answer boundary screens have a thickness of 13/16".

Screens are available in laminate or wood veneer.

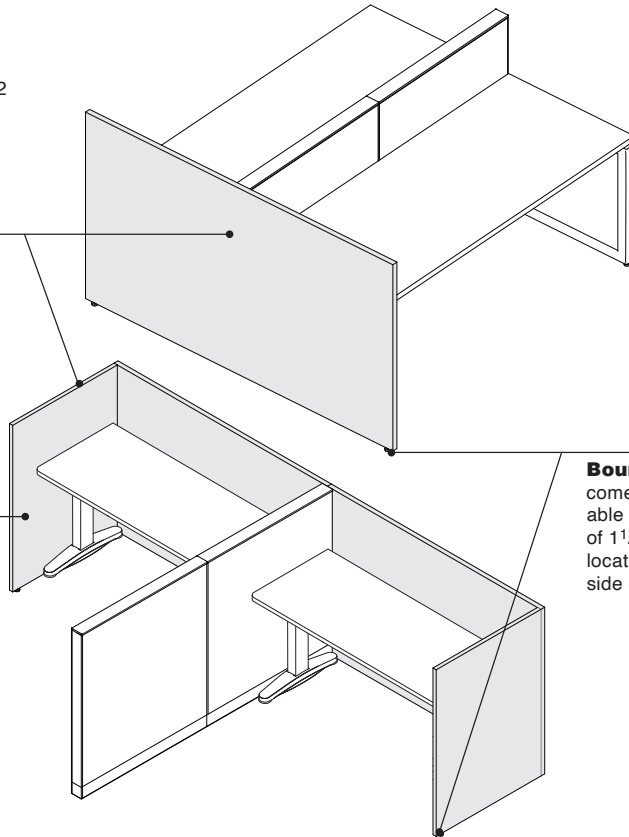

Boundary screens come standard with adjustable glides, with a range of 1 1/2". The glides are located 1 1/2" from the outside of each edge.

Product Details

Boundary screens are available in two attachment versions – single-connect and dual-connect.

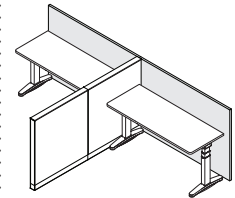

Single-connect boundary screens attach to the Answer panel using an end-of-run junction.
Tip: Single-connect boundary screens do not require any additional attachment for stability.

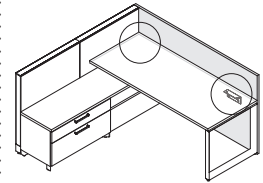

Dual-connect boundary screens have two attachment points: the end-of-run junction, and an adjacent worksurface or 1.5-H or higher storage unit.

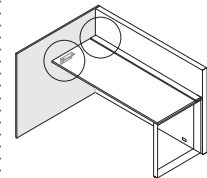

Boundary screens with dual connections can be used in place of a leg to support a worksurface.

Actual Dimensions

Height	30", 36", 42", 48", and 54"
Single-Sided Width	27", 33", 39", 45", 51", 57", 63", 69", and 75"
Spanning Width	51", 57", 63", 69", and 75"
Split Width	25 1/2", 31 1/2", 37 1/2", 43 1/2", 49 1/2", 55 1/2", 61 1/2", 67 1/2", and 73 1/2"
Return Width	18", 24", and 30"
Thickness	13/16"

Note: Answer boundary screen widths can also be specified parametrically.

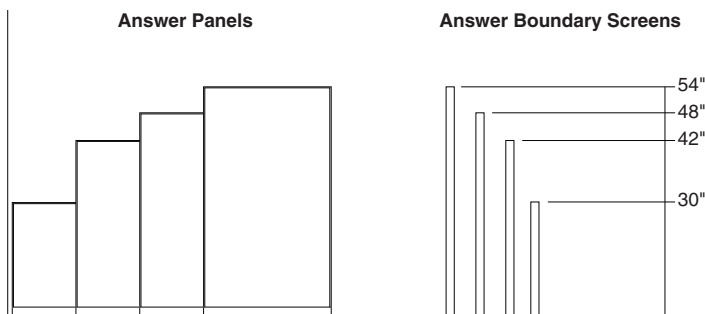

Boundary screen heights align with thin trim top cap panel heights at 30", 42", 48", and 54". 36"H boundary screens are also available.

Boundary screens have modular heights and widths. Parametric widths are allowed from 24"W to 75"W increasing in 1/16" increments. Boundary screen return widths are available at 18", 24", and 30", and are also available parametrically from 18"W to 75"W increasing in 1/16" increments.

Answer boundary screens are available in five different configurations.

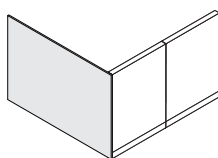

1. Single-sided boundary screens provide boundary to one side of an Answer panel and are specified as either left or right. Right handed application is shown above.

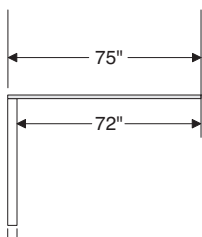

3" Answer panel thickness

Single-sided boundary screens will always include the 3" thickness of the Answer panel to which they attach. Minimum width for a single-sided boundary screen is 27" (24" inside, and 3" for the Answer panel thickness). The maximum width is 75" (72" inside, and 3" for Answer panel thickness). The above image is shown with a right handed application.

Note: The above image shows a 75" specified width. The planning width is 72".

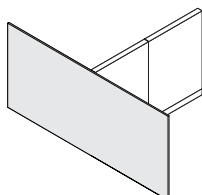

2. Spanning boundary screens use one screen segment to provide boundary of equal widths to both sides of an Answer panel.

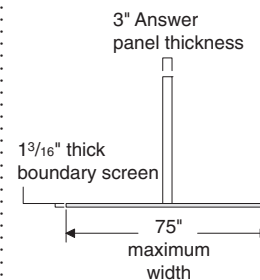

Spanning boundary screens always extend in equal dimension from the panel to which they attach and include the 3" thickness on the Answer panel. Minimum width for a spanning boundary screen is 51" (48" inside, and 3" for the Answer panel thickness). The maximum width is 75" (72" inside and 3" for Answer panel thickness). *Note: The above image shows a 75" specified width. The planning width is 72".*

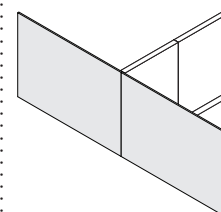

3. Split boundary screens use two screen segments to provide boundary to both sides of an Answer panel. Both sides of a split boundary screen are the same height.

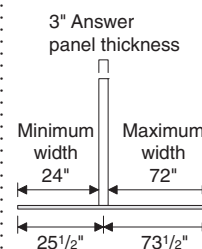

Split boundary screens can either be equal or asymmetrical in dimension from the panel to which they attach and include the 3" thickness of the Answer panel. Minimum width for a split boundary screen is 25 1/2" (24" inside, and 1 1/2" for half of the Answer panel thickness) for each side of the panel. The maximum width is 73 1/2" (72" inside, and 1 1/2" for half of the Answer panel thickness) for each side of the panel.

Note: The above image shows a 25 1/2" specified right width and a 73 1/2" specified left width. The planning right width is 24" and the planning left width is 72".

Answer Boundary Screens, continued

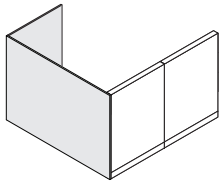

4. Single-sided L return boundary screens provide boundary and additional privacy to one side of an Answer panel. Both screen segments (primary and return screen) are the same height and are specified as either left or right handed. Right handed application is shown above.

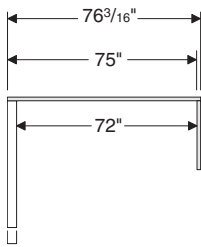

3" Answer panel thickness

Single-sided L return boundary screens in modular widths have inside clearance in 6" increments to wrap standard width worksurfaces in 6" increments. Panel connected segments (the primary screens) are available in widths of 27" (24" inside, and 3" for Answer panel thickness) to 75" (72" inside, and 3" for Answer panel thickness). The inside width of modular returns are 18", 24", or 30". There is an additional 1³/₁₆" that will be added to the return width for the primary screen thickness. Both boundary screens have equal heights and are specified as either left or right handed. Right handed application is shown above. *Note: The above image shows a 75" specified width. The planning width is 72".*

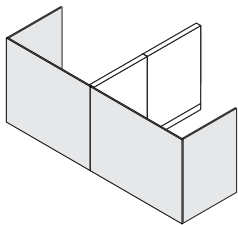

5. Split L return boundary screens consist of four segments to provide boundary and additional side privacy to both sides of an Answer panel. Split L configuration screens do not have to have symmetrical widths, but must have the same height.

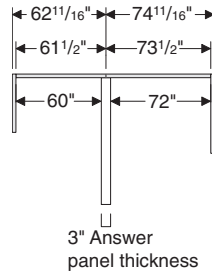

Split L return boundary screens in modular widths have inside clearance in 6" increments to wrap standard width worksurfaces from 24" to 72" in 6" increments for each side of the split. The inside width of modular returns will be 18", 24", or 30". There is an additional 1³/₁₆" that will be added to the return width for the primary boundary screen thickness. Each panel connected segment is available in widths from 25¹/₂" (24" inside, and 1¹/₂" for half of the Answer panel thickness) to 73¹/₂" (72" inside, and 1¹/₂" for half of the Answer panel thickness). *Note: The above image shows a 61¹/₂" specified left width and a 73¹/₂" specified right width. The planning left width is 60" and the planning right width is 72".*

Connections

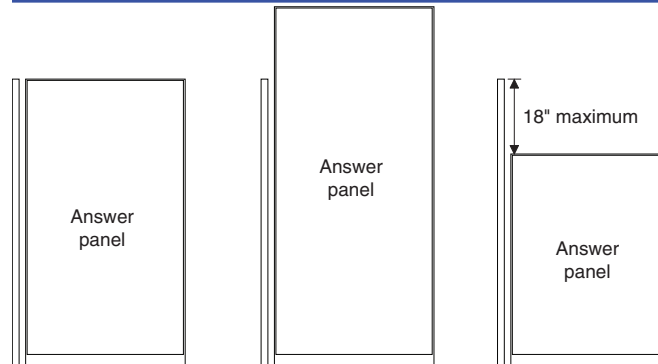

Boundary screens can be attached to Answer panels that are of equal height to the screen, higher than the screen, or lower than the screen.

Boundary screens cannot be more than 18" taller than the Answer panel to which they connect.

Boundary screens may be shorter than connecting Answer panel in 6" increments between 12" and 36". In this situation, specify change-of-height trim separately.

Tip: When specifying a boundary screen equal to the height of the Answer panel, order a same height end-of-run junction for height of Answer panel with the "omit trim" option.

Tip: When specifying a boundary screen shorter than the height of the Answer panel, order a same height end-of-run junction for height of Answer panel with the "omit trim" option, and order a change-of-height trim.

Tip: When specifying a boundary screen taller than the height of the Answer panel, order a same height end-of-run junction for height of Answer panel with the "omit trim" option.

When boundary screen is shorter than connecting Answer panel in increments not supported with standard trim heights, order change-of-height trim through Specials.

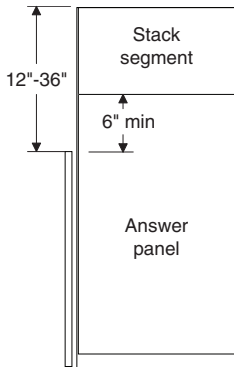

When attaching to Answer panels with a stacking junction, boundary screens must be at least 6" lower than the start of the stacking segment.
Tip: Order change-of-height end-of-run trim separately.

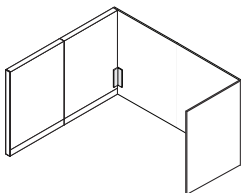

On both single- and dual-connect boundary screens, there is a metal cover plate that covers the connection bracket that connects the boundary screen to the end-of-run junction. The cover is located 22" from the bottom of the screen and is 3"W and 14"H.

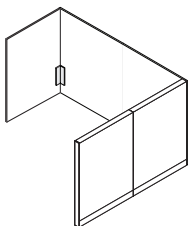

Return segments also have a second metal cover plate that covers the connection bracket that connects the return to the primary screen segment.

Surface Materials

Boundary screens

- Laminate
- Wood veneer

Edge on laminate

- Plastic

Bracket cover

- Paint

Tip: When specifying the paint finish for the bracket cover, select a finish that compliments the selected laminate or veneer finish.

Open Line laminates with grain direction

can only be applied vertically. Open Line laminates are not allowed on boundary screens that are 60" or wider, or have segments that are 60" or wider.

On single-sided boundary screens,

horizontal wood grain laminates and veneers can be applied up to 75"W. Vertical wood grain laminates can be applied up to 59"W. Vertical wood grain veneers can be applied up to 75"W.

On spanning boundary screens,

wood grain laminates and veneers can be horizontal grain direction up to 75"W. Vertical wood grain laminates can be applied up to 59"W. Vertical wood grain veneers can be applied up to 75"W.

On split boundary screens,

horizontal wood grain laminates and veneers can be applied up to 73½"W. Vertical wood grain laminates can be applied up to 59"W. Vertical wood grain veneers can be applied up to 73½"W.

On split boundary screens with horizontal grain direction,

the grain pattern of two screen segments may not align.

All boundary screen sides

will have the same finish applied.

Application Topics

Answer boundary screens

fulfill the same stability requirements as Answer panels of the same heights and widths. Answer boundary screens do not support hang-on components.

▶ See *Stability Guidelines*, page 140

Boundary screens

attach at the end-of-run location of an Answer panel with thin trim top detail.

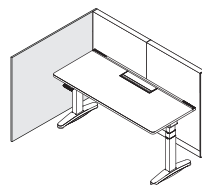

Single-connect boundary screens

are for use with height-adjustable or freestanding worksurfaces when storage is not available or is shorter than 1.5-High.

▶ Page 80

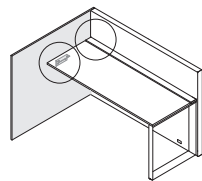

Dual-connect boundary screens

can be used as a support in place of a leg. They are not for use with height-adjustable worksurfaces.

▶ Page 80

Applications using split boundary screens must use dual connections on both sides, or a single connection on each side.

Boundary screens

cannot attach to an Answer end-of-run junction where an Answer panel and beam foot is being used.

Boundary screens can attach to panels with frameless glass application.

Tip: Use the base junction height as the connecting panel height.

Boundary screens are not for use with wall starts.

One single-sided boundary screen

may be attached at the end of the Answer panel. If the intent is to have a boundary screen in both directions of the panel, use either spanning or split boundary screens.

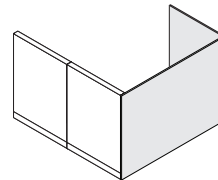

Single-sided and split boundary screens

are available left and right handed. This is determined by the user facing the attaching Answer panel. Left sided application is shown above.

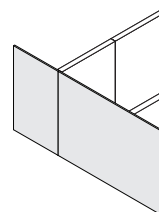

Split boundary widths do not have to be symmetrical.

Dual-connect boundary screens of any configuration

must always utilize both connection points to ensure stability.

Dual-connect split and spanning boundary screens

must have a properly secured worksurface and/or storage units on each side of the Answer panel to make a second connection.

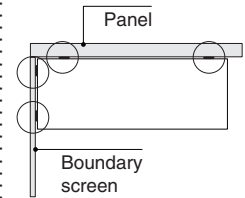

When dual-connect screens

are attaching to a worksurface, the worksurface must attach to the panel in two points along the back or sides of the panel.

Tip: The second connection must be within 6" of the end of the panel-supported worksurface. Connection point to worksurface must have a flat back edge.

When using boundary screens with low storage,

the storage must be attached to the panel using storage-to-panel connectors. Storage units must be 1.5-High or higher. The storage must be connected to the panel at the opposite end of the boundary screen.

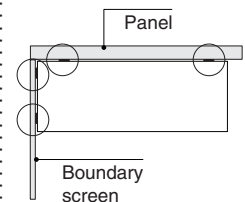

Worksurface supports

cannot overlap with the secondary dual-connect bracket.

If storage specified on one side of an Answer panel

does not have a storage to panel connection, the boundary screen must be single-connect.

Side support bracket

can be used adjacent to dual-connect boundary screens and Answer panel connections at the end-of-run junction.

Tip: Other panel-mounted supports such as a cantilever will not fit.

Answer Boundary Screens, continued

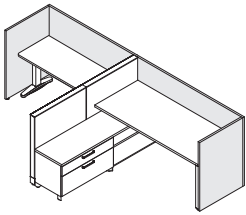

Applications that have a panel connected work-surface on one side and a freestanding table on the other side of the panel must use single-connect boundary screens.

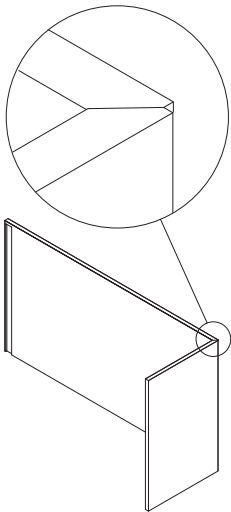

All L return boundary screens have a step miter detail at the adjoining edge.

Understanding Panels—Square and Oval Trim



Statement of Line	86
<hr/>	
Product Details	
Answer Panel Overview—Square and Oval Trim	90
Panel Buildups	91
Base Junctions—Square and Oval Trim	92
Change-of-Height—Square and Oval Trim	96
Off-Module Panel Connector—Square and Oval Trim	98
Stacking Junctions—Square and Oval Trim	100
Base Horizontal Frame Packages—Square and Oval Trim	104
Stacking Horizontal Frame Packages—Square and Oval Trim	106
Frameless Glass Screens—Square Trim Only	108
Stability Guidelines	140

Statement of Line



Understanding
 ▶ Page 92
 Specifying
 ▶ Pages 402–410

Base Junctions—Square and Oval Trim

	In-Line Base Junctions	L-Base Junctions	T-Base Junctions	X-Base Junctions	End-of-Run Base Junctions	V-Base Junctions	Y-Base Junctions	Wall-Start Junctions
30"H	●	●	●	●	●	●	●	
42"H	●	●	●	●	●	●	●	●
48"H	●	●	●	●	●	●	●	●
54"H	●	●	●	●	●	●	●	●
66"H	●	●	●	●	●	●	●	●
78"H	●	●	●	●	●	●	●	●

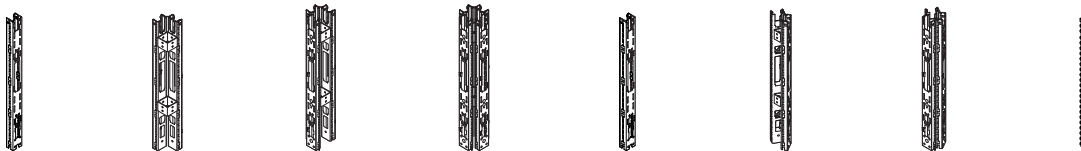

Understanding
 ▶ Page 100
 Specifying
 ▶ Pages 413–417

Stacking Junctions—Square and Oval Trim

	Stacking In-Line Junctions	Stacking L Junctions	Stacking T Junctions	Stacking X Junctions	Stacking End-of-Run Junctions	Stacking V Junctions	Stacking Y Junctions	Wall-Start Junctions
12"H	●	●	●	●	●	●	●	●
18"H	●	●	●	●	●	●	●	●
24"H	●	●	●	●	●	●	●	●

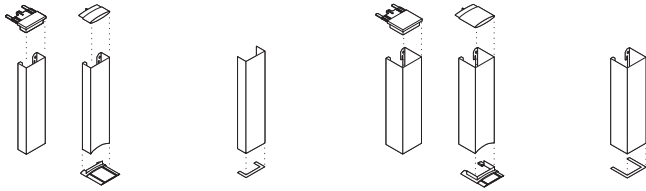

Understanding
 ▶ Page 96
 Specifying
 ▶ Pages 424–426

Panels—Square and Oval Trim

Change-of-Height Trim—Square and Oval Trim

	Standard Slim Profile	Stacking Slim Profile	Standard Cable Routing	Stacking Cable Routing
12"H	●	●	●	●
18"H	●	●	●	●
24"H	●	●	●	●
30"H	●	●	●	●
36"H	●	●	●	●

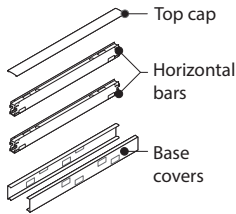

Understanding
 ▶ Page 104
 Specifying
 ▶ Pages 428 and 430

Base Horizontal Frame Packages—Square and Oval Trim

18"W	24"W	30"W	36"W	42"W	48"W	60"W	72"W
●	●	●	●	●	●	●	●



Understanding
 ▶ Page 106
 Specifying
 ▶ Page 431

Stacking Horizontal Frame Packages—Square and Oval Trim

18"W	24"W	30"W	36"W	42"W	48"W	60"W	72"W
●	●	●	●	●	●	●	●

Panels—Square and Oval Trim

Statement of Line, continued

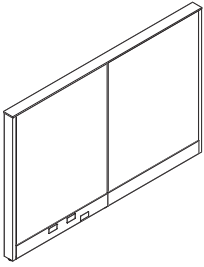

Understanding
▶ Page 104
Specifying
▶ Page 432

Spanning Top Caps—Square Trim

36"W 42"W 48"W 60"W 72"W 78"W 84"W 90"W 96"W

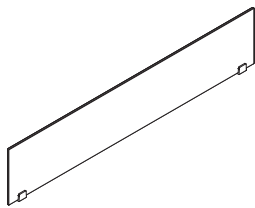

Understanding
▶ Page 108
Specifying
▶ Page 433

Frameless Glass Screens—Square Trim Only

24"W 30"W 36"W 42"W 48"W 60"W 72"W 78"W 84"W 90"W 96"W

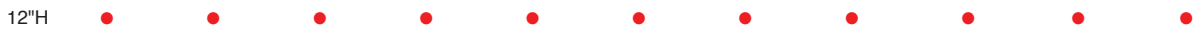

Answer Panel Overview—Square and Oval Trim

Panel buildups allow you to create unique configurations by mixing surface materials and colors on segmented panels. Order skins and horizontal frame packages separately.

Panel frame is made up of two major elements—vertical base junctions and base horizontal connecting bars. Vertical junctions are ordered separately.

Stacking components can be used on both panel buildups.

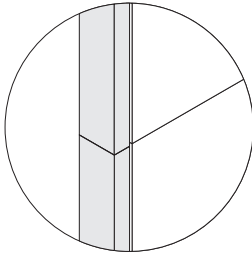

Standard change-of-height trim has either a rounded bottom edge to fit the curve of oval panel top caps or a straight edge to fit square panel top caps.

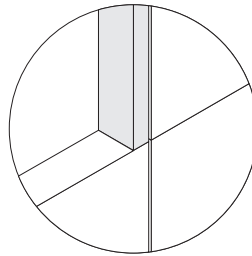
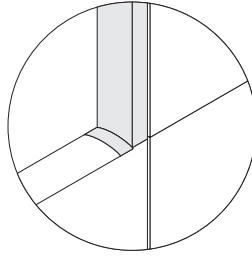

Leveling glides adjust to install panels on uneven floors. Range is 2³/₄".

Actual Dimensions

Height 29³/₈", 41³/₄", 47¹⁵/₁₆", 54¹/₈", 66¹⁵/₃₂", and 78²⁷/₃₂"

Note: Height is minimum from floor to top of top caps. Leveling glides can extend 2³/₄".

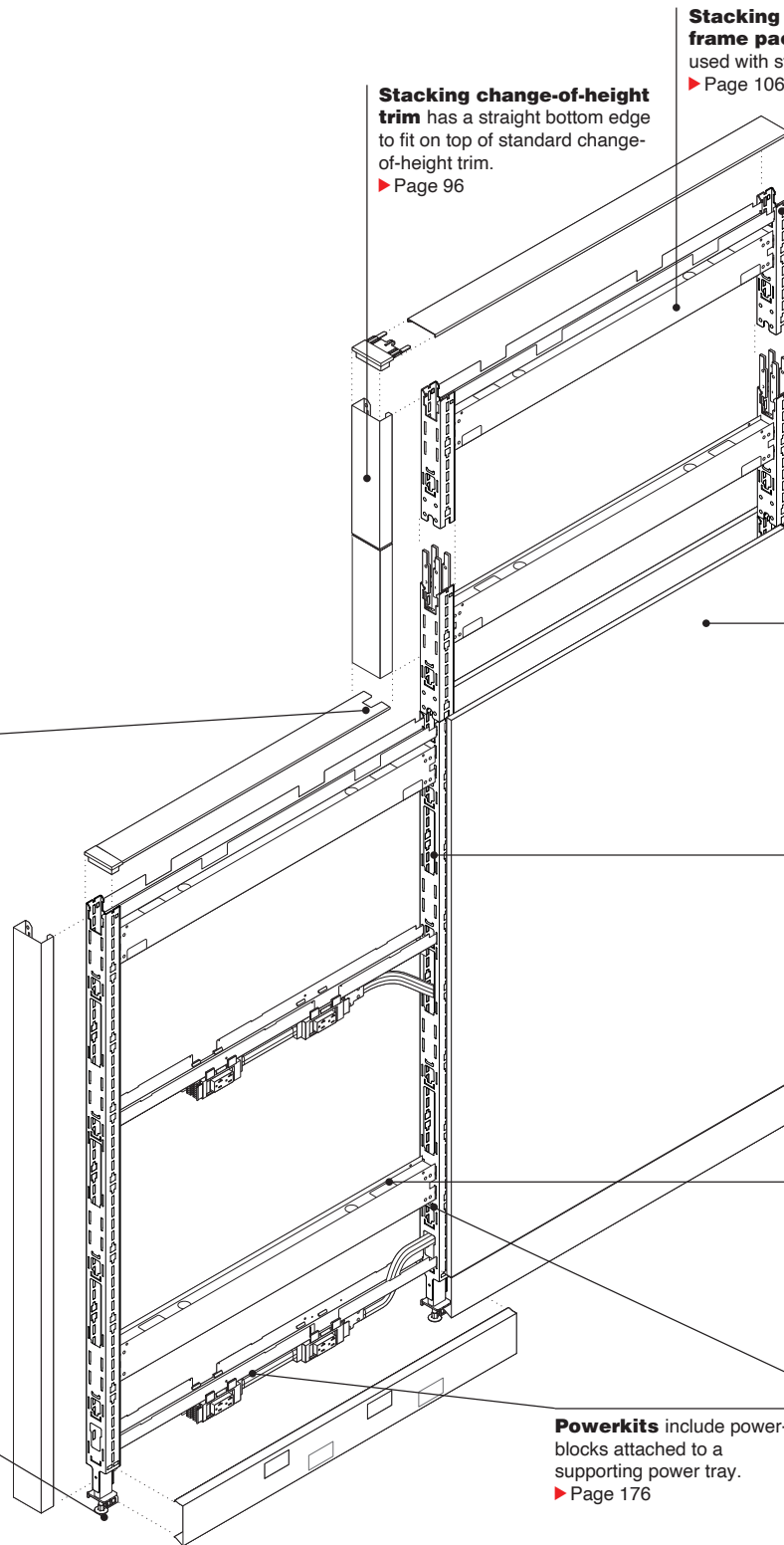

Stacking change-of-height trim has a straight bottom edge to fit on top of standard change-of-height trim.

Stacking horizontal frame package must be used with stacking junctions.

Stacking junctions are always shared by adjacent panels and can be used in panel buildups. They are available for in-line, L, T, V, X, Y, and end-of-run configurations.

Skins attach to frame without tools and can be removed and repositioned easily.

Base junctions, are always shared by adjacent panels. They are available for in-line, L, T, V, X, Y, and end-of-run configurations. Wall-start junctions and off-module connectors are also available.

Base horizontal connecting bars lock into the vertical junctions at the top and the bottom location of base junction to provide structural stability for the panels.

Powerkits include powerblocks attached to a supporting power tray.

Alternate powerkit harness routing can be accommodated through the junction opening. In in-line applications installed on uneven floors, route harness through junction opening to prevent harness from being exposed.

Panel Buildups

Panels—Square and Oval Trim

Order panel components separately to create unique configurations.

1. Begin by planning your frames. Junctions determine height and horizontal connecting bars determine width.

1a. Corner junctions can easily be reconfigured by adding or removing a junction post (available on junctions shipped on or after October 10, 2011).

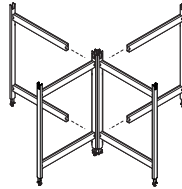
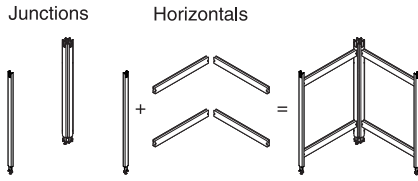

2. Order skins for both sides of panel.

Exception: Windows accommodate both sides of the panel.

Performance tackable acoustical fabric-covered skins

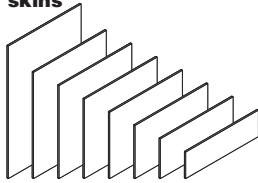

Tackable acoustical fabric-covered skins

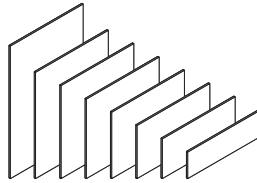

Steel skins (12"H, 18"H, and 24"H have ribbed and perforated options)

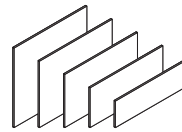

Laminate skins

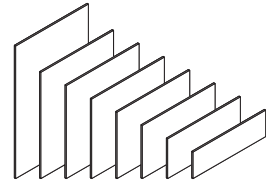

Wood skins

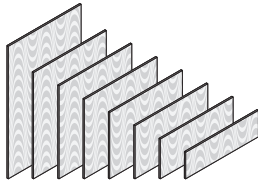

Tip: Wood skin sets are available for 42", 48", 54", and 66" panel heights.

Back painted glass skins

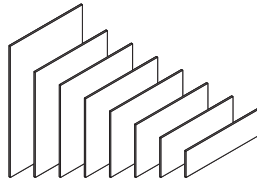

Markerboard skins

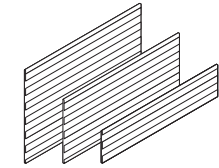
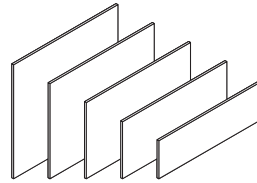

Slatwall

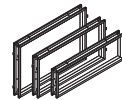

Windows

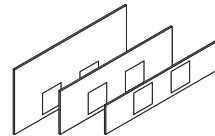

Technology skins

Answer allows a wide variety of skin arrangements to meet specific functional and aesthetic needs. Skins are not dedicated to a specific location and can be used anywhere on the face of the panel.

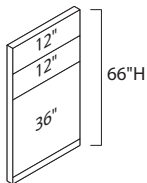

When planning skin segments, add skin heights together and add an additional 6" for total height.

Skins = 12" + 12" + 36" = 60"
 Trim = 6"
 Total = 66"H

3. Specify powerkits where you will need power.

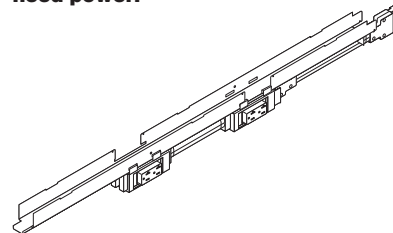

Base Junctions—Square and Oval Trim

Base junctions complete the structure of panel buildups. Answer panels always share a junction with adjacent panels. You order the style of junction you need separately.
 ▶ Specifying square and oval, page 402

Corner junction cap aligners ensure correct fit with adjacent panel top caps.

Opening in top of junction allows lay-in cable routing beneath top caps.

Slots in junction accept the panel's horizontal bars every 12", cable trays every 6", and powerkits every 12" vertically.

Slotted channels in junction accommodate worksurface supports and overhead storage components at 1" increments.

Trim is included with L, T, V, and end-of-run junctions to finish exposed surfaces. Trim is standard with paint and available with a fabric wrapped option.

Large openings are used to route power through an L, T, X, V, or Y base junction.

Leveling glides adjust to install panels on uneven floors. Range is 2¾".

Junction cap is included with junction when needed. Caps are available in two styles: square or oval.

Skins attach to junction with concealed hardware.

Lay-in cable routing is accommodated in base area.

Product Details

Answer is available with three styles of top trim - thin, square, and oval. Base junctions are specified with desired style. Styles can not be mixed between adjacent panels.

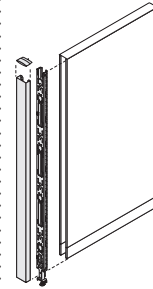

End-of-run base junction includes junction, vertical trim, and junction cap. Select square or oval style trim. End-of-run trim adds 1" to footprint.

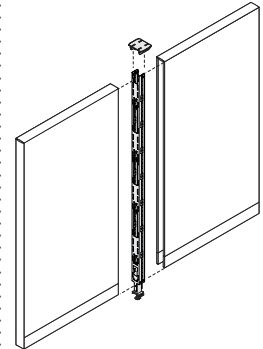

In-line base junction includes junction and plastic top cap aligner. Select square or oval style trim.

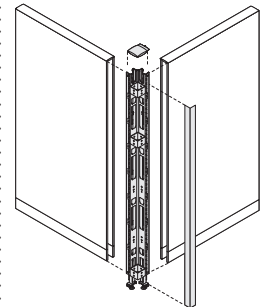

L-base junction includes junction, vertical trim, junction cap, and plastic top cap aligner. Select square or oval style trim.

Actual Dimensions

Depth 3"

Height 28⁷/₁₆"*, 40³/₄", 47", 53¹/₈", 65¹/₂", and 77³/₈"

*Note: Wall-start junctions are not available 28⁷/₁₆".

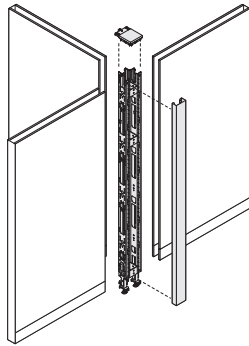

T-base junction includes junction, vertical trim, junction cap, and two plastic top cap aligners. Select square or oval style trim.

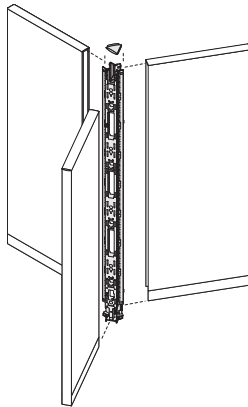

Y-base junction includes junction, junction cap, and two plastic top cap aligners. Select square or oval style trim.

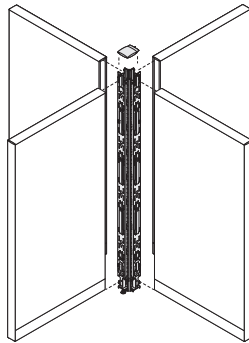

X-base junction includes junction, junction cap, and three plastic top cap aligners. Select square or oval style trim.

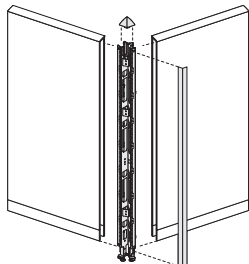

V-base junction includes junction, vertical trim, junction cap, and plastic top cap aligner. Select square or oval style trim.

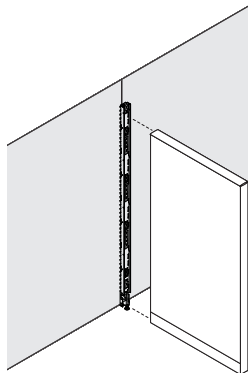

Wall-start junction secures to the stud in a structural wall or drywall fasteners can be used. Vertical trim is not needed. Also used in off-module applications. Wall-start junction does not add any dimension to panel run.

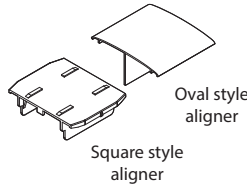

An **in-line top cap aligner** is included with in-line junctions. Select square or oval style.

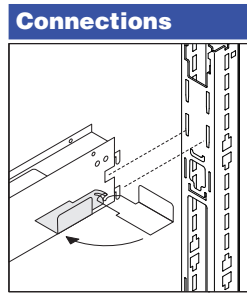

Quick lock on both ends of the panel's horizontal connecting bars engage the junction in a tight structural connection.

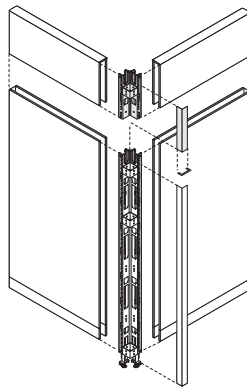

Base junctions can accept a stacking junction of the same type only.
Example: An L-base junction will accept an L-stacking junction.

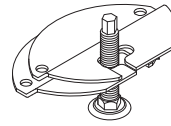

Floor anchor brackets are available to secure junctions to the floor to prevent panel movement. Brackets are intended for use in seismic zones and may require additional code approvals.

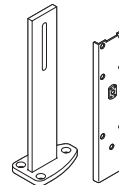

Junction stabilizer bracket can be used to add rigidity to a panel run or when using a Universal sliding door. Bracket must be bolted to a concrete floor. For junctions manufactured before October 10, 2011 use TS7SB. For junctions manufactured on or after October 10, 2011 use TS7SBNJ.

Bracket foot is visible on one side of panel when installed.

Junction stabilizer bracket blocks power routing in the panel base and just above the base areas. The bracket covers the slots on the junction where the powerkit connects in these two zones. It also blocks the ability for a powerkit harness, pass-through powerkit, or modular harness to route in the base area from an adjacent panel.

Junction stabilizer bracket also blocks lay in of cables in base area of panel.

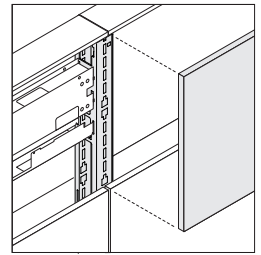

Skins extend onto junction and meet skin of adjacent panel. The slotted channel of the junction is accessible between these two skins.

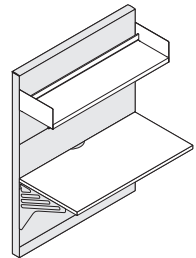

Panels can support work-surfaces, shelves, and bins.

Wiring and Cabling

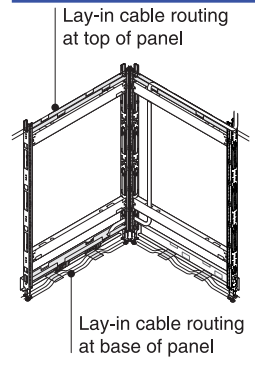

Lay-in cable routing is accommodated in the top of junctions. Lay-in cable and power routing is accommodated in base area.

Base Junctions—Square and Oval Trim, continued

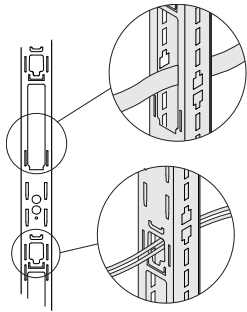

As an alternative to lay-in cable routing, horizontal routing of power and cables can be accommodated through openings in junctions.

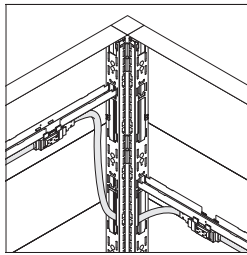

Modular harnesses that are 43" or 80" are available to change the height at which you are routing power kits or to route power from the panel base to different heights.

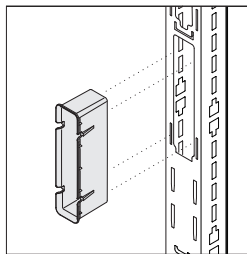

Junction tall sleeves can be ordered to cover the exposed metal edges in the large cable routing opening of junctions. Tall junction sleeve can only be used on junctions manufactured on or after October 10, 2011.

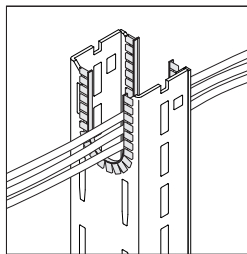

Lay-in junction cable sleeves can be added in the field to cover the exposed metal edges in lay-in cable space.

Surface Materials

Base junction

- Black paint
- Tip: Junction is hidden when properly installed.*

Junction cap—Square

- Paint

Junction cap—Oval

- Plastic

Vertical trim

- Paint (standard)
- Fabric (option)

Fabric application is standard in the warp horizontal direction. Warp vertical direction is available as an option.
 ▶ See *Specification Guidelines for Directional Fabrics*, page 674, for more information.

Application Topics

Stacking junctions can be used with any height base junction.

Stability Guidelines

for application rules.
 ▶ See page 140



Carpet gripper glide caps may be added to panel glides to help hold panel in place (used only on junctions manufactured on or after October 10, 2011).

Change-of-Height—Square and Oval Trim

Change-of-height trim is available for base panels and stacking panels. It is used in in-line and corner applications.
 ▶ Specifying square and oval, page 424

Stacking change-of-height trim has a straight bottom edge to fit on top of standard change-of-height trim.

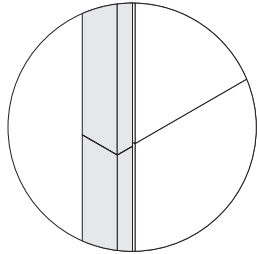

Oval standard change-of-height trim has a rounded bottom edge to fit the curve of top caps.

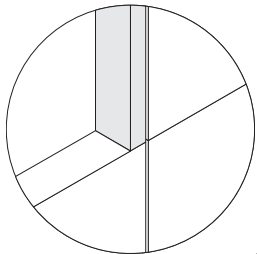

Top cap on lower panel must be change-of-height. Remember to specify the change-of-height top cap option on the lower panel for either square or oval trim applications.

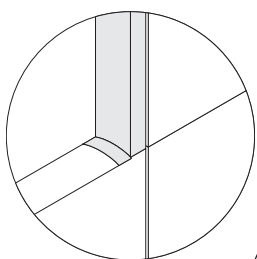

Square standard change-of-height trim has a square bottom edge to fit square top caps.

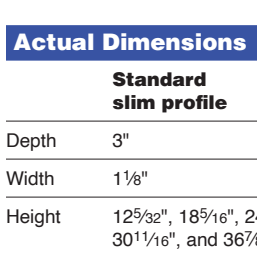

Junction cap is included with standard change-of-height trim. Cap is available in two styles - square and oval.

Plastic aligner is included with stacking change-of-height trim.

Top cap from base panel is used to trim the top of the stacked panel.

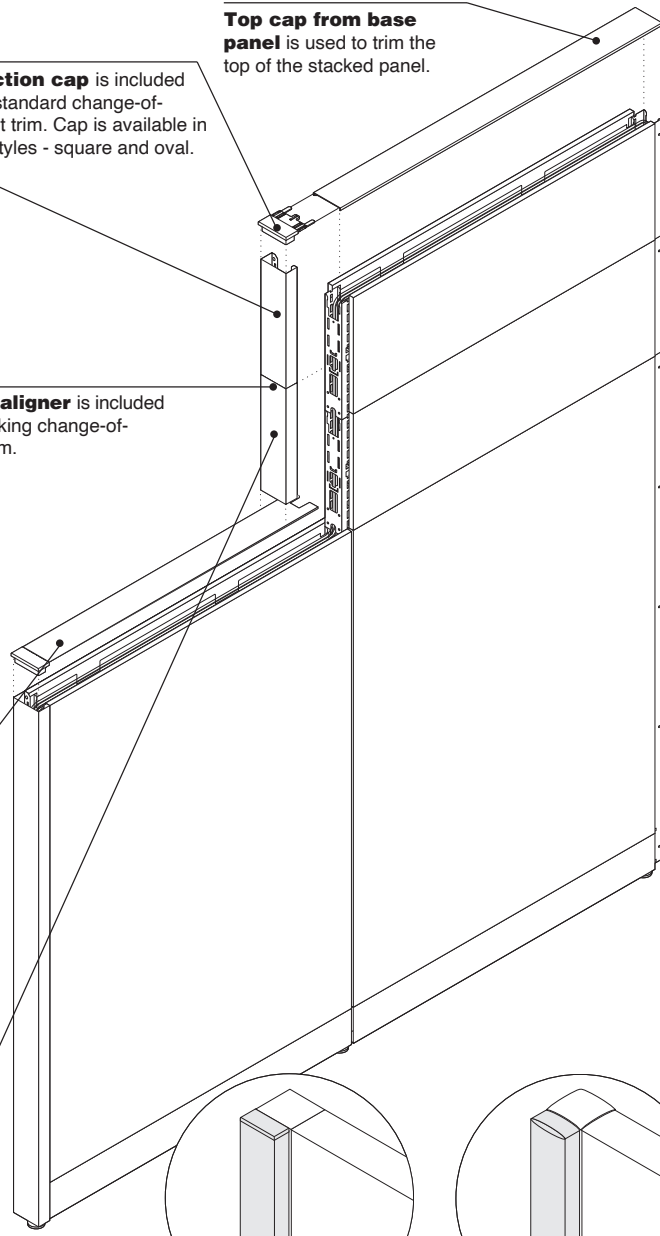

L-junction application square trim

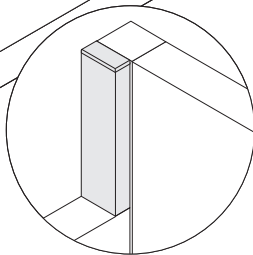

L-junction application oval trim

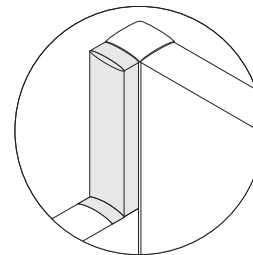

Product Details

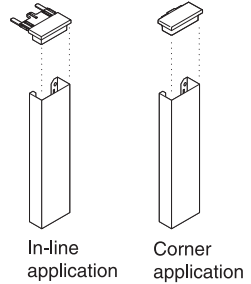

Square standard slim trim includes junction cap. In-line or corner application must be specified. Available in 12"H, 18"H, 24"H, 30"H, and 36"H.

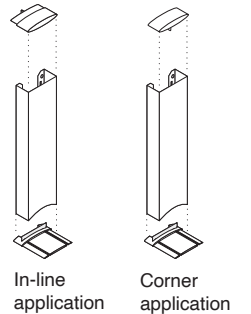

Oval standard slim trim includes junction cap and top cap filler. Plastic filler is not the same filler that ships with cable-routing trim. In-line or corner application must be specified. Available in 12"H, 18"H, 24"H, 30"H, and 36"H.

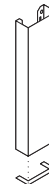

Stacking slim trim includes plastic aligner and works with both square and oval trim styles. Available in 12"H, 18"H, and 24"H.

Actual Dimensions

	Standard slim profile	Stacking slim profile	Standard cable-routing	Stacking cable-routing
Depth	3"	3"	3"	3"
Width	1 1/8"	1 1/8"	2 1/4"	2 1/4"
Height	12 ⁵ / ₃₂ ", 18 ⁵ / ₁₆ ", 24 1/2", 30 ¹¹ / ₁₆ ", and 36 ⁷ / ₈ "	12 ⁵ / ₃₂ ", 18 ⁵ / ₁₆ ", and 24 1/2"	12 ⁵ / ₃₂ ", 18 ⁵ / ₁₆ ", 24 1/2", 30 ¹¹ / ₁₆ ", and 36 ⁷ / ₈ "	12 ⁵ / ₃₂ ", 18 ⁵ / ₁₆ ", and 24 1/2"

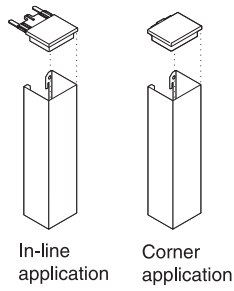

Square standard cable-routing trim includes junction cap. In-line or corner application must be specified. Available in 12"H, 18"H, 24"H, 30"H, and 36"H.

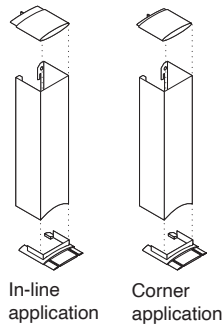

Oval standard cable-routing trim includes junction cap and top cap filler. Plastic filler is not the same filler that ships with slim trim. In-line or corner application must be specified. Available in 12"H, 18"H, 24"H, 30"H, and 36"H.

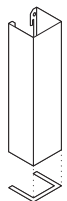

Stacking cable-routing trim includes plastic aligner and works with both square and oval trim styles. Available in 12"H, 18"H, and 24"H.

36"H standard change-of-height trim is the tallest trim available. If the area you need to trim is taller than 36"H, use stacking change-of-height trim.

Wiring & Cabling

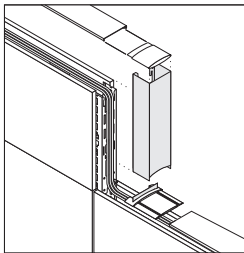

Oval cable-routing trim allows lay-in cable routing in change-of-height applications.

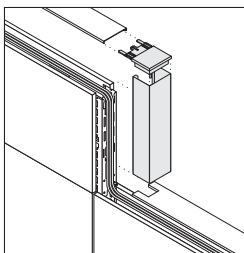

Square cable-routing trim allows lay-in cable routing in change-of-height applications.

Surface Materials

Change-of-height trim

- Paint
- Fabric (option)

Fabric application is standard in the warp horizontal direction. Warp vertical direction is available as an option.

▶ See *Specification Guidelines for Directional Fabrics*, page 674, for more information.

Square junction cap

- Paint

Oval junction cap and filler

- Plastic

Aligner

- Black plastic only

Application Topics

Change-of-height top cap option must be specified on the lower panel.

Square trim top caps have a notch in one or both ends to accommodate change-of-height applications.

Oval trim top caps are shortened on one or both ends to accommodate change-of-height applications.

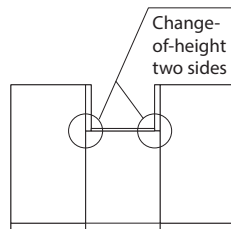
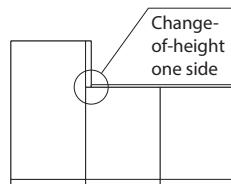

Specify change-of-height top caps at one end unless the panel is adjacent to taller panels on both sides. Then specify a top cap change-of-height on both ends.

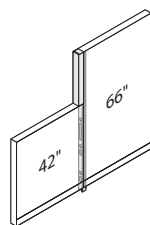

Specify the tallest height junction to connect your panels. A 66"H junction would be shared between these panels.

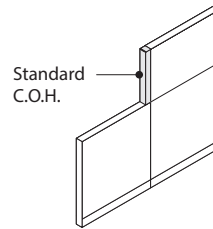

When stacking only one panel on your base panel with square or oval trim, always use standard change-of-height trim.

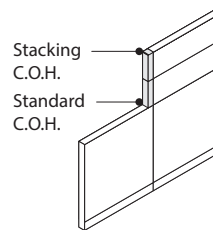

When stacking more than one panel on your base panel, use standard change-of-height trim on the first tier. Only the second tier requires stacking change-of-height trim.

Off-Module Panel Connector—Square and Oval Trim

Off-module panel connectors allow a fin wall to be attached off-module to a spine wall in 1" increments.

► Specifying, page 412

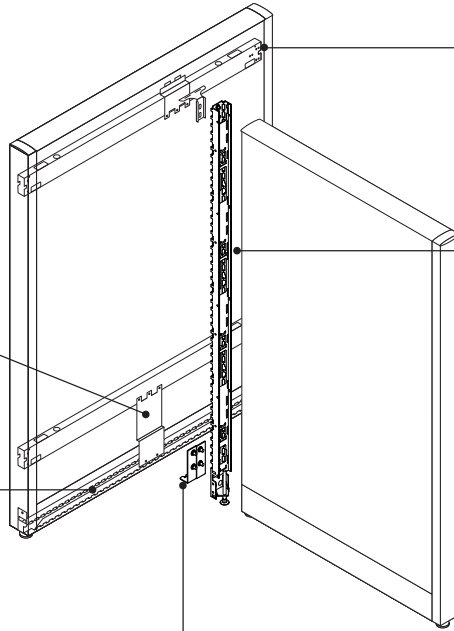

Top brackets attach to top horizontal connecting beam and secure top of the wall-start junction. If fin wall is 12", 18", or 24" shorter than spine wall, the top horizontal connecting bar can be lowered to attach brackets.

Wall-start junction must be ordered separately.

Bottom bracket attaches to lower horizontal connecting beam and secures to lower portion of bottom channel.

Bottom channel has slots in 1" increments to attach panel off-module. Channel must match width of panel and be attached between two junctions.

Bottom bracket for wall-start junction attaches the junction and bottom channel to secure the lower portion of the wall-start junction.

Product Details

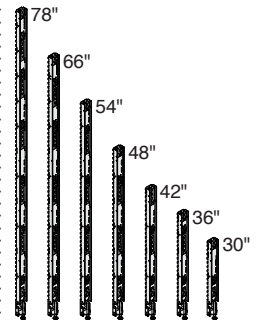

Wall-start junctions connect to the off-module panel connectors to start a panel run off from the spine. Available in 42"H, 48"H, 54"H, 66"H, and 78"H. Wall-start junction must match the height of the fin wall. Wall-start junctions are ordered separately.

Connections

Off-module fin wall must always be the same height, or shorter than the spine wall.

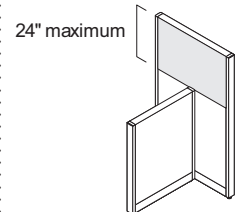

When fin wall is more than 24" shorter than the spine wall, an additional horizontal beam must be added to the spine wall at the same height as the fin wall. Order a stacking horizontal frame kit.

Spine wall skins must be segmented with a seam matching the height of the shorter fin wall. This allows access to the top bracket and the spine wall horizontal beam.

Actual Dimensions

Width 22½", 34½", 40½", 46½", 58½", and 70½"

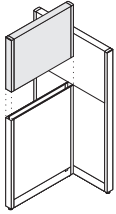

When stacking on the fin panel, the spine wall skins must be segmented with a seam matching the height of the fin base panel.

When stacking wall-start junctions in an off-module application, the off-module panel connector connects to the base wall-start junction.

Two off-module panels can be connected back to back at the same location.

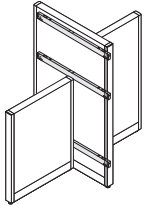

When connecting two off-module fins at different heights on either side of the spine panel, an additional horizontal beam must be ordered and installed at the same height of the shorter fin panel.

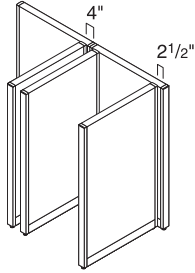

An off-module fin wall cannot connect flush to the end of a panel in the spine wall. The closest connection point will leave a 3" tail on the spine including the end-of-run trim.

An off-module fin wall cannot attach at a junction in the spine wall. There is a 2" area of dead space on either side of the junction rendering a total of 4" dead space.

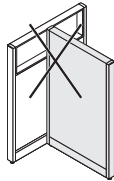

An off-module fin wall cannot be installed over a window that is located at the top of a spine panel.

Wiring & Cabling

Wiring and cabling components cannot be routed internally from a spine wall to an off-module fin wall without cutting openings in the spine wall skin.

Tip: It is recommended that you route wiring and cabling through the spine wall.

Modular power components should be used to bring power from the spine wall to the workstation.

Surface Materials

Off-module bracket

- Black paint

Tip: Bracket is hidden when properly installed.

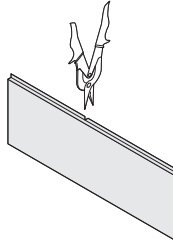

Off-module installation requires field modification of the light seal on the top skin. Surface covering is not affected.

Application Topics

Stability Guidelines for Application Rules

▶ Page 140

Stacking junctions

can be used with any height base junction.

Bins, shelves, and workspaces cannot be attached off-module.

Off-module panel connector works with both square and oval style trims.

Top cap filler included in package is only used with oval style trims. Square style trims do not require a top cap filler.

When using a wall-start junction

manufactured before October 10, 2011 with an off module panel connector manufactured on or after October 10, 2011 the "old" bottom bracket must be used. It can be ordered from Service Parts, part number T500938MP. If using an old off-module panel connector manufactured before October 10, 2011 with a wall-start junction manufactured on or after October 10, 2011 the bottom bracket included with the off module panel connector should be used.

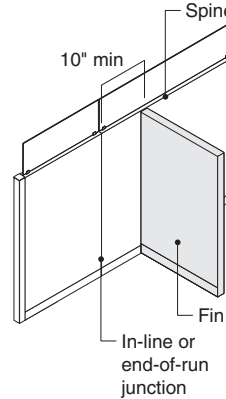

When using frameless glass on a spine panel with a same height off-module panel connections, the off-module cannot connect within 10" of an end of run or in-line junction connection.

Stacking Junctions—Square and Oval Trim

Stacking junctions allow you to adjust the panel heights within a workstation.
 ▶ Specifying square and oval, page 413

Junction top cap is standard on base panel junctions. Use the same top cap in stacking configurations.

Stacking junctions are always shared by adjacent panels. They are available for in-line, L, T, V, X, Y, end-of-run, and wall-start configurations.

Stacking horizontal frame package, specified separately, must be used with stacking junctions. Each package includes one horizontal connecting bar.

Stacking junction trim is included with L, T, V, and end-of-run stacking junctions. Stacking end-of-run trim adds 1" to footprint.

Plastic aligner is included with L, T, V, and end-of-run stacking junctions.

Fork connectors are included with stacking junction for proper connection to the base panel.

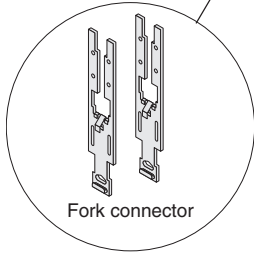

Top cap and junction cap from base panel are used to trim the top of the panel.

Slots in stacking junctions are identical to base junctions to accept horizontal connecting bars, power-kits, and cable trays.

Cables can be laid into top of base panel. During initial installation, it is important to keep cabling loose so it can be temporarily moved aside to install stacking fork connector at a later date.

Base panel must always have two horizontal connecting bars. The bars must be in place prior to adding fork connectors into the junction.

Product Details

All existing base panels can accept a stacking junction.

Aligner is included with fabric-wrapped vertical trim but may not be needed depending on the thickness of the fabric.

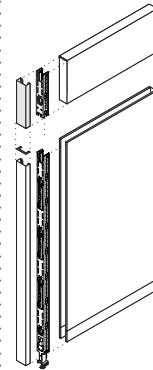

End-of-run stacking junction includes junction, fork connectors, vertical trim, and plastic trim aligner. End-of-run stacking trim adds 1" to footprint.

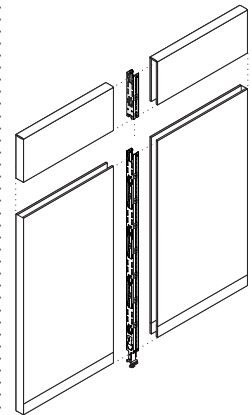

In-line stacking junction includes junction and fork connectors.

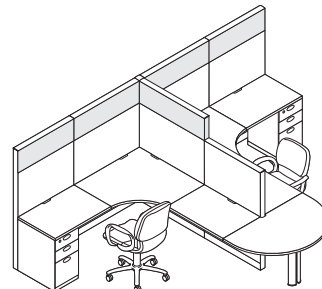

Actual Dimensions

Depth 3"

Height 12³/₈", 18¹/₂", and 24³/₄"

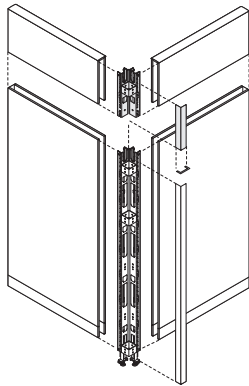

L-stacking junction includes junction, fork connectors, vertical trim, and plastic trim aligners.

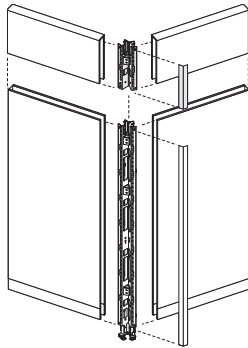

V-stacking junction includes junction, fork connectors, vertical trim, and plastic trim aligners.

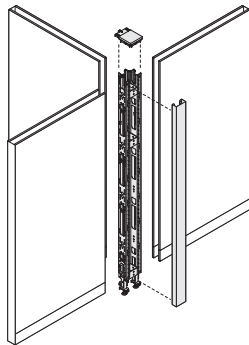

T-stacking junction includes junction, fork connectors, vertical trim, and plastic trim aligners.

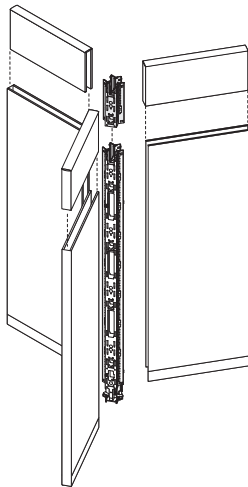

Y-stacking junction includes junction and fork connectors.

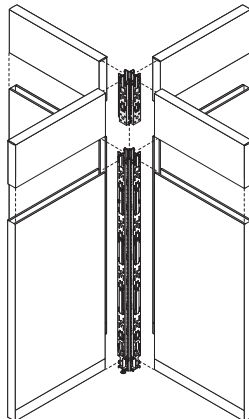

X-stacking junction includes junction and fork connectors.

Full L, T, V, and end-of-run square and oval vertical trim is available through Service Parts in 30", 42", 48", 54", 66", and 78" heights if a segmented visual on the trim is not desired.

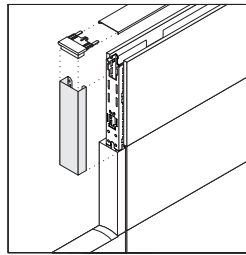

Stacking change-of-height trim is used when you stack on a change-of-height configuration. The bottom edge of stacking trim is straight so it can join with the top of the standard change-of-height trim. Oval standard change-of-height trim is rounded at the bottom to fit around the top cap of the lower panel. Square standard change-of-height trim has a straight bottom edge to fit with square top trim.

► Page 426

Standard skins, cable trays, and powerkits are used in stackable solutions. To maximize the benefits of stackability, consider matching the skin height to the stacking junction height.

Connections

Skins on base panel do not need to be removed to install a stacking junction in most cases.

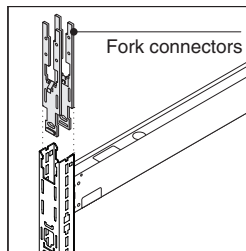

Fork connector is included with stacking junction for proper connection to the base panel. Two fork connectors are included with each in-line, end-of-run, L, and V stacking junctions, three are included with T and Y stacking junctions, and four are included with X stacking junctions. One fork connector is included with each wall-start stacking junction.

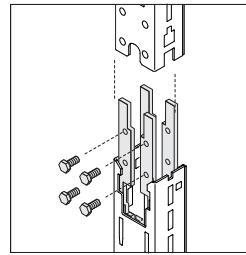

Fork connectors secure into the base junction. Stacking junction is bolted to fork connectors.

Wiring & Cabling

Lay-in cable routing at top of stacking junctions

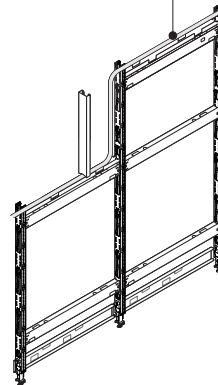

Lay-in cable routing is accommodated in top of stacking junctions.

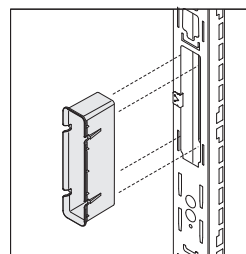

Junction tall sleeve can be ordered to cover the exposed metal edges in the large cable routing openings of junctions manufactured on or after October 10, 2011.

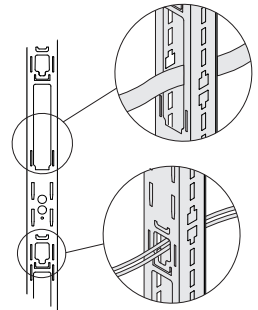

As an alternative to lay-in cable routing, horizontal routing of power and cables can be accommodated through openings in stacking junctions.

Powerkit installation for stacking components is the same process as for installation in base panels.

Surface Materials

Stacking junction

- Black paint
- *Tip: Junction is hidden when properly installed.*

Vertical trim

- Paint
- Vertical surface fabric (option)

Stacking Junctions—Square and Oval Trim, continued

Application Topics

Stacking Stability Guidelines provides detailed information on applications.
▶ Page 140

Maximum height that can be stacked on a base panel is 36", consisting of one 24"H and one 12"H, or two 18"H stacking junctions.

Maximum height that an Answer panel configuration can reach is 90".

Maximum number of stacking junctions that can be added to a base panel is two.

Any height base panel can be used with stacking junctions.

Bins and shelves can hang from the first stacked tier only.

For initial installations order the appropriate top cap for your stacked segment, while you are specifying the base panel.

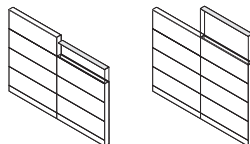

Change-of-Height Top Cap Standard Top Cap

For retrofit installations you will have to order a new top cap through Service Parts based on application changes.

When adding stacking junctions to base panels made prior to January 2000, you must replace vertical trim on end-of-run base junction. We recommend replacement of L base junction trim and standard change-of-height trim because the new trim can be easily removed, while the existing trim will be trapped by the stacking junction. To determine if you have trim made prior to January 2000, remove trim piece. If there are hooks at the top of your trim, you need to replace it. Replacement trim is available through Service Parts.

Base Horizontal Frame Packages—Square and Oval Trim

Base horizontal frame packages include horizontal connecting bars that lock into vertical junctions and complete the structure of a panel. A top cap and pair of base trims are also included. Cable tray and base cable tray are available as options.

► Specifying square and oval, pages 428 and 430

Top cap snaps onto top of panel skins. Two styles of top cap are available - square and oval. Top caps to accommodate change-of-height are also available.

Quick lock connects horizontal bars to vertical junctions for quick assembly.

Horizontal connecting bars lock into vertical junctions. The top bar can be lowered in 12" increments to a maximum of 24" from the top position. The bottom bar must always be positioned in the lowest slot in a junction.

Optional cable tray can be used for additional support of cables. Additional cable trays can be installed and arranged at various heights within the frame for communications access and cable routing.

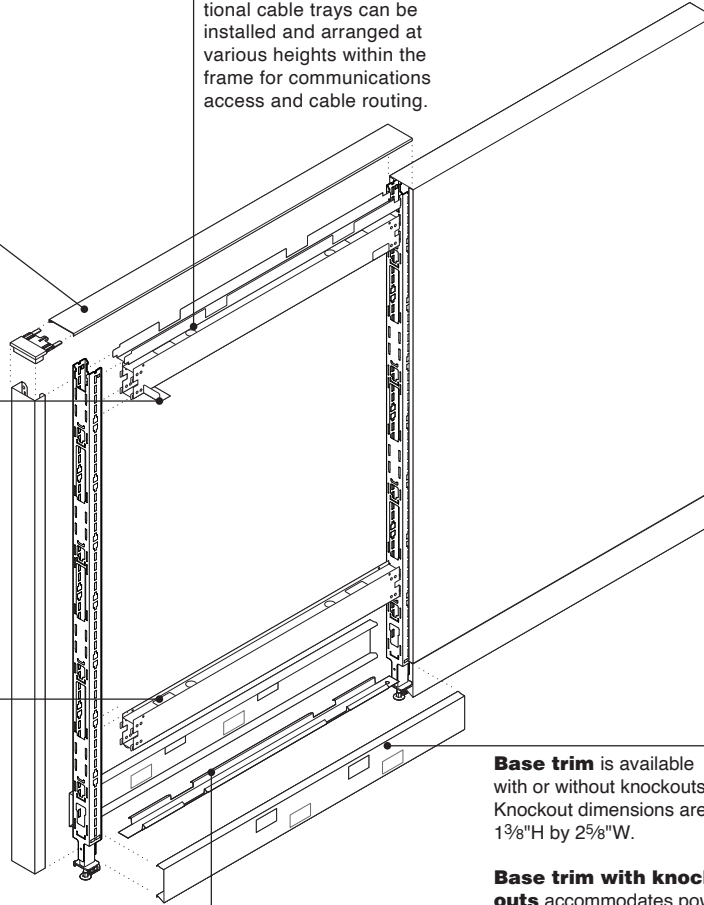

Base trim is available with or without knockouts. Knockout dimensions are 1 3/8"H by 2 5/8"W.

Base trim with knockouts accommodates power and communication terminations. Top knockout is for power, bottom knockout is for communication. Filler to close unused openings is available from Service Parts (TS7BTFSR).

Optional base cable tray can be used to support lay-in of cables.

Product Details

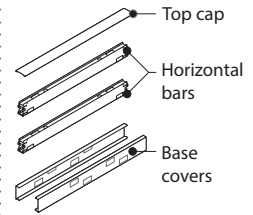

Horizontal frame packages are available when you want to build up your own panel. The package includes all the components of a panel except the skins so you can order the skins separately to mix combinations of skin surface materials and colors. These frame packages do not include vertical junctions. Cable trays and base cable trays are optional.

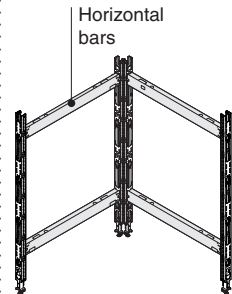

Two horizontal connecting bars must be used in each base panel.

Horizontal bars determine panel width. They are not dedicated to a specific panel height; any horizontal bar can be used or reused with any junction height.

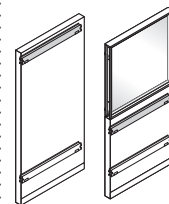

Top horizontal bar may be lowered to allow for a 12"H, 18"H, or 24"H glass window to be placed at the top of the panel. Bottom horizontal bar in base panel must remain in lowest position.

Actual Dimensions

Width 17 15/16", 23 15/16", 29 15/16", 35 15/16", 41 15/16", 47 15/16", 59 15/16", and 71 15/16"

Base trim height 3 3/4"

Receptacle Opening

Width of opening 2 5/8"

Height of opening 1 3/8"

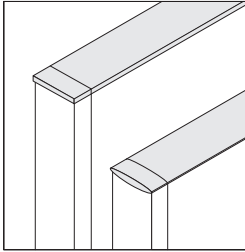

Top caps are available in three styles - thin, square, and oval. This section is about square and oval trims. Horizontal frame packages should be specified with square or oval trim. Thin, square, and oval top caps can not be mixed between adjacent panels.

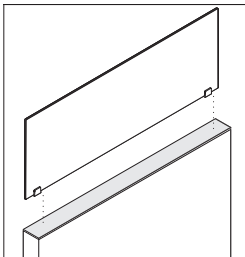

Omit top cap option is available on square trims and should be selected when adding a frameless glass screen to the top of the panel or when spanning a single top cap across multiple panels.

Spanning top caps are available for square style trims.

When spanning a single top trim across multiple panels, select the omit top cap option and specify a spanning top cap separately. Top cap width must match total width of spanned panels.

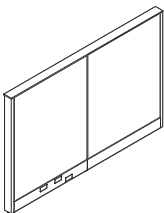

Spanning top caps can only be used in an in-line condition. They cannot span over a corner junction.

Spanning top caps can be used on any panel height.

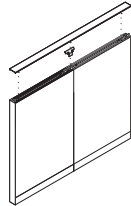

In-line spanning top cap lightseals should be specified separately for each in-line panel joint the top cap spans.

Omit base trim option should be selected when using skins to the floor or open base trim.

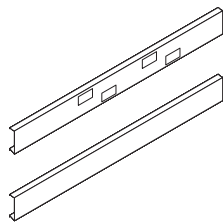

Base trims are available with or without knockouts. Base trims with knockouts accommodate power and communication terminations. Plain base trims with no knockouts do not.

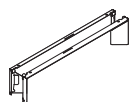

Open base trims are available. They do not accommodate power and data routing or entry in the base. Open base trim can only be added on a junction manufactured on or after October 10, 2011.

Open base trims are specified by omitting base trims and ordering open base trim kit separately.

Open base trims occupy the same space as the standard base trims. Open base trims occupy the bottom 3/4" of the panel; the height of the opening is 2 1/2".

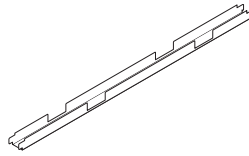

Cable tray can be positioned every 6" vertically above the base to support cable routing.

Cable tray can accept added cable carriers attached below tray to expand horizontal cable management options. ▶ See *Montage Specification Guide* for cable carrier (ZCC).

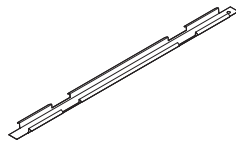

Base cable tray is used only in the base to support lay-in cable routing in the base. Base cable tray cannot be used if omit base trim option is selected for one or both sides of panel or if open base trim is used.

Connections

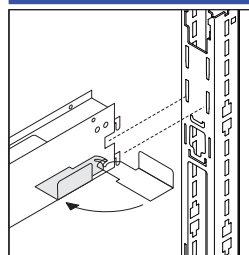

Quick lock on both ends of the panel's horizontal connecting bars engage the junction in a tight structural connection.

Wiring & Cabling

Vertical lay-in cable routing

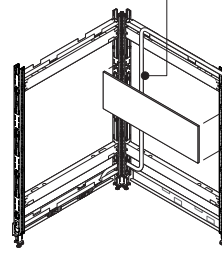

Vertical lay-in cable routing can be accommodated behind skins.

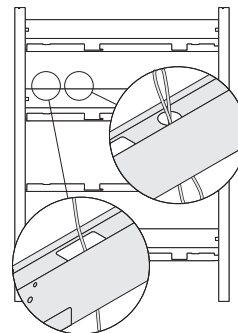

As an alternative to lay-in cable routing, vertical routing of power and cables through panel interior can be accommodated by openings in horizontal connecting bars. Also, see lay-in utility packages for vertical lay-in of power and cables. ▶ Page 166

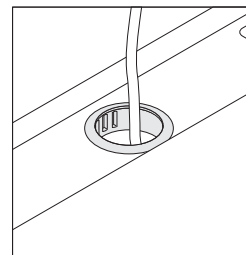

Feed-through horizontal connecting bar cable sleeves can be added in the field to finish the exposed metal edges of vertical cable pass-through openings.

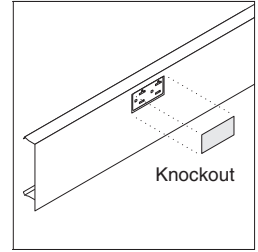

Knockouts in base trim can be removed in the field where needed. Knockout dimensions are 1 3/8"H by 2 5/8"W.

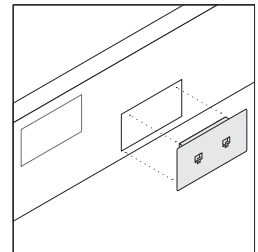

Communication outlets attach to openings in panel base trim. Order communication outlets from an outside vendor. Knockouts for communication in base accommodate modular furniture size only.

Surface Materials

Top cap and base trim
• Paint color chosen on base trim will also apply to the top cap. They are not chosen independently.

Horizontal connecting bars
• Black paint
Tip: Components are hidden when properly installed.

Application Topics

Use a cable tray to provide extra support for 60"W and 72"W full skins where people may lean against the panel.

Stacking Horizontal Frame Packages—Square and Oval Trim

Stacking horizontal frame package provides structural stability for stacking junctions.

► Specifying, page 431

Horizontal connecting bar is included with each stacking horizontal frame package.

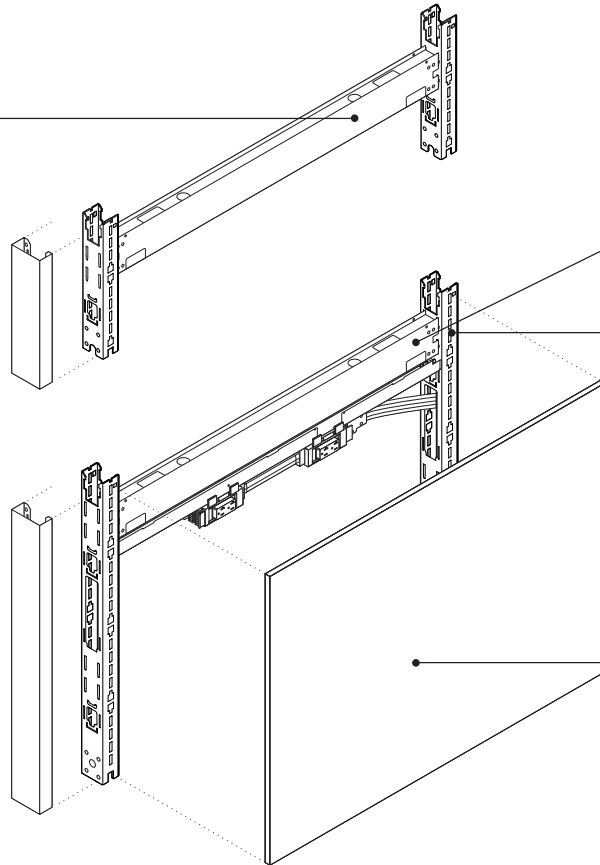

Each stacking segment must have one horizontal connecting bar.
Exception: If a window is used with stacking junctions, a horizontal connecting bar is not needed.

Each stacking junction is specified separately.
► Page 413

Skins, ordered separately, are added to both sides of stacking frame.

Actual Dimensions

Width 17¼", 23¼", 29¼", 35¼", 41¼", 47¼", 59¼", and 71¼"

Product Details

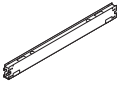

Stacking horizontal frame package includes one horizontal connecting bar. Stacking junction is not included.

Stacking horizontal frame package is available in eight widths— 18", 24", 30", 36", 42", 48", 60", and 72"—to match panel width. These horizontal connecting bars are identical to those in horizontal frame packages and can be re-used with any type of junction.

Connections

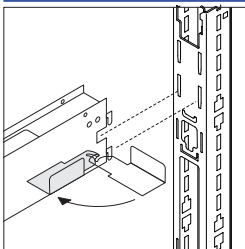

Quick-lock mechanism on the horizontal connecting bar engages the stacking junction in a tight structural connection.

Base panel must always have two horizontal connecting bars.

Wiring & Cabling

Vertical lay-in cable routing

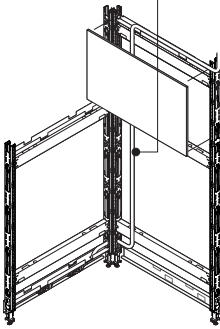

Vertical lay-in cable routing can be accommodated behind skins.

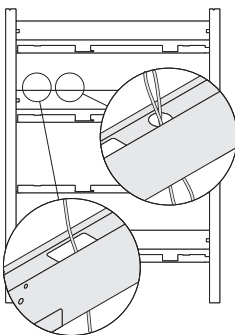

Vertical routing of power and cables through panel interior is accommodated by openings in horizontal connecting bars.

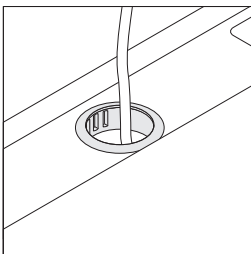

Feed-through horizontal connecting bar cable sleeves can be added in the field to finish the exposed metal edges of vertical cable pass-through openings.

Power kit installation for stacking components is the same process as for installation in base panels.

Surface Materials

Stacking horizontal frame package

- Black
- Tip: Components are hidden when properly installed.*

Application Topics

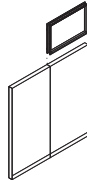

When stacking a 12"H, 18"H, or 24"H window, a stacking horizontal frame package is not needed. Remember, the base panel always has two horizontal connecting bars for support.

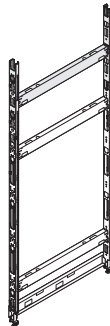

When double stacking junctions, each stacking junction must have a horizontal beam.

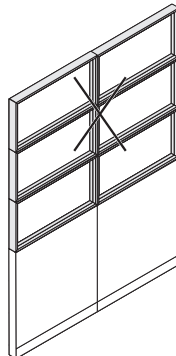

No more than two windows can be stacked on top of each other.

Stacking horizontal frame package

is used when additional horizontal bar is needed in off-module application. See off-module guidelines.

Stacking Stability Guidelines

provides detailed information on applications.
▶ Page 140

Frameless Glass Screens—Square Trim Only

Frameless glass screen can be added to the top of a panel to help define space and provide some privacy while still providing access to natural light and promoting communication between adjacent workers.

► Specifying, page 433

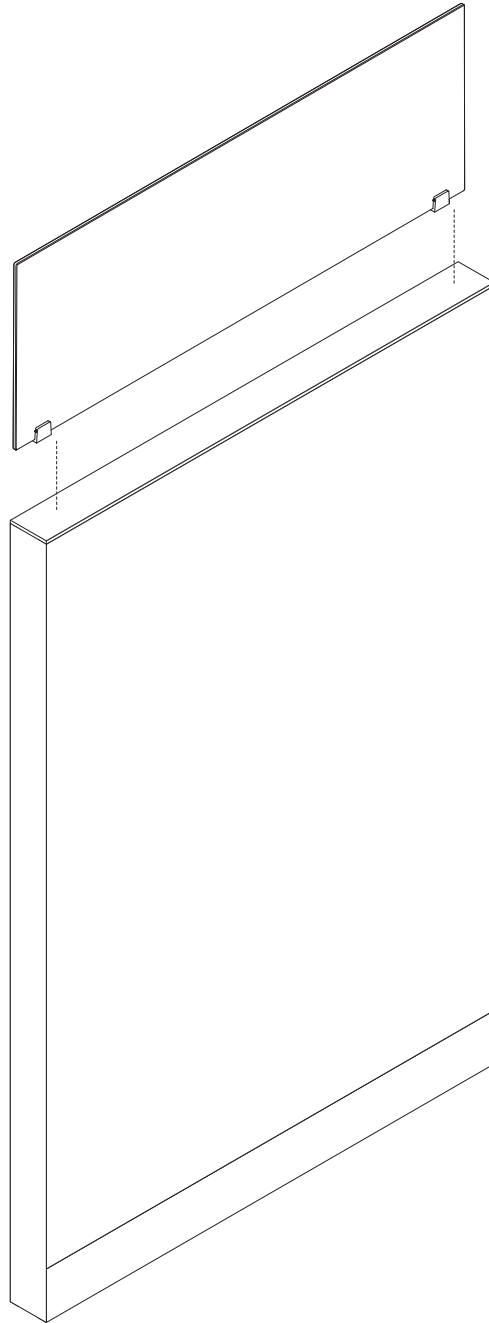

Product Details

Frameless glass screen is secured to horizontal connecting bar by supports below the top cap and brackets above the top cap. Two brackets are used above the top cap to attach the glass to the panel on 24"–60"W panels. Three brackets are used on panels 78" and wider.

Frameless glass can be used on panels with thin or square profile trim.

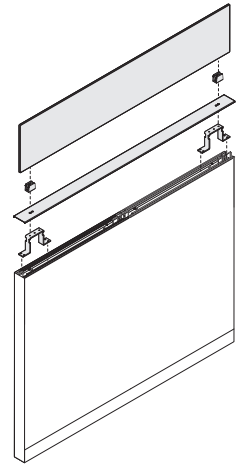

Frameless glass kit includes glass screen, brackets, supports, and top cap with holes to accommodate brackets.

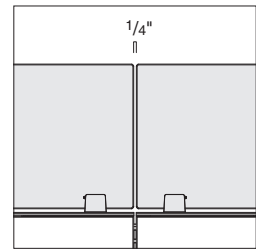

Gap between adjacent glass screens is $\frac{1}{4}$ ".

Actual Dimensions

Glass Width – standard: 23 $\frac{3}{4}$ ", 29 $\frac{3}{4}$ ", 35 $\frac{3}{4}$ ", 41 $\frac{3}{4}$ ", 47 $\frac{3}{4}$ ", 59 $\frac{3}{4}$ ", 71 $\frac{3}{4}$ ", 77 $\frac{3}{4}$ ", 83 $\frac{3}{4}$ ", 89 $\frac{3}{4}$ ", and 95 $\frac{3}{4}$ "

Glass Width – change-of-height one end square trim: 22 $\frac{1}{2}$ ", 28 $\frac{1}{2}$ ", 34 $\frac{1}{2}$ ", 40 $\frac{1}{2}$ ", 46 $\frac{1}{2}$ ", 58 $\frac{1}{2}$ ", 70 $\frac{1}{2}$ ", 76 $\frac{1}{2}$ ", 82 $\frac{1}{2}$ ", 88 $\frac{1}{2}$ ", and 94 $\frac{1}{2}$ "

Glass Height: 11 $\frac{3}{4}$ "

Glass Thickness: $\frac{3}{8}$ "

Surface Materials

Glass

- 6500 Clear Glass
- 6530 Frosted Glass

Tip: Frosted glass is a laminated construction. There may be variation in color, texture, and finish between the sample of 6530 Frosted Glass and the actual product.

Brackets

- Paint

Top cap

- Paint
- Wood veneer

Application Topics

Frameless glass screen

can be placed on the top of a panel only. Top beam in the panel must be located in the top position of the frame in order to support frameless glass. Frameless glass can be used on base panels or stacking panels.

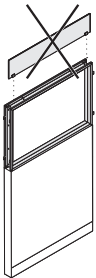

Frameless glass screen cannot be used when a window is located in the top position of the panel.

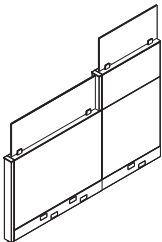

Change-of-height top cap option is available to allow for positioning of glass next to change-of-height trim on one side only. Glass is shortened and top cap provided supports change-of-height slim one end only.

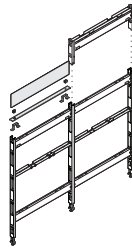

When using frameless glass on a 48"H panel in a change-of-height condition with a taller panel, the taller panel must use a 48"H base junction and stacking junction to achieve the taller height to allow correct upper horizontal beam placement.

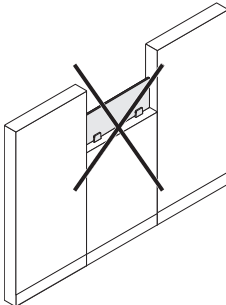

Frameless glass screen will not fit between two change-of-height trims.

Frameless glass kit

is available without glass screen to accommodate customer's own glass. See chart of field installed glass size requirements for specific dimensions required for glass to fit in frameless glass brackets. Steelcase recommends the use of safety glass meeting ANSI 297.1 for field installed glass. Check with your local building authority for requirements in your area.

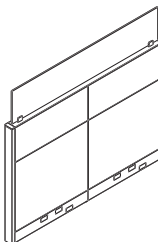

A single frameless glass screen can span over two or more panels.

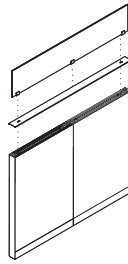

90" and 96" wide frameless glass screen kits include three brackets. Two brackets attach to supports below the top cap. The third bracket attaches only to the top cap through a hole that is drilled in the top cap by the installer on site.

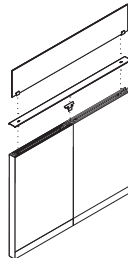

In-line spanning top cap lightseal must be specified separately when used in this application. Spanning top cap lightseal attaches to underside of top cap to fill space between skin lightseals. Specify one for each in-line junction the frameless glass screen spans.

A template tool is available from Service Parts (**T511082SR**) to assist in locating where holes are to be drilled on the beam of an existing panel to allow supports to be attached. This only applies to beams produced prior to September 2009. Beams produced after this date include holes to allow frameless glass supports to be attached.

Field-Installed Glass Size Requirements

Style Number	Maximum Height	Maximum Width	Thickness Range (min-max)
Standard			
TS71224SFG	11¾"	23¾"	.350-.400"
TS71230SFG	11¾"	29¾"	.350-.400"
TS71236SFG	11¾"	35¾"	.350-.400"
TS71242SFG	11¾"	41¾"	.350-.400"
TS71248SFG	11¾"	47¾"	.350-.400"
TS71260SFG	11¾"	59¾"	.350-.400"
TS71272SFG	11¾"	71¾"	.350-.400"
TS71278SFG	11¾"	77¾"	.350-.400"
TS71284SFG	11¾"	83¾"	.350-.400"
TS71290SFG	11¾"	89¾"	.350-.400"
TS71296SFG	11¾"	95¾"	.350-.400"

Change-of-Height—one end slim

TS71224SFG	11¾"	22½"	.350-.400"
TS71230SFG	11¾"	28½"	.350-.400"
TS71236SFG	11¾"	34½"	.350-.400"
TS71242SFG	11¾"	40½"	.350-.400"
TS71248SFG	11¾"	46½"	.350-.400"
TS71260SFG	11¾"	58½"	.350-.400"
TS71272SFG	11¾"	70½"	.350-.400"
TS71278SFG	11¾"	76½"	.350-.400"
TS71284SFG	11¾"	82½"	.350-.400"
TS71290SFG	11¾"	88½"	.350-.400"
TS71296SFG	11¾"	94½"	.350-.400"

Tip: Field installed glass should always be tempered. Laminated glass must not be used.

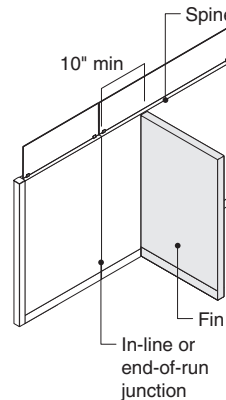

When using frameless glass on a spine panel with a same height off-module panel connections, the off-module cannot connect within 10" of an end-of-run or in-line junction connection.



Understanding Shared Components

	
Statement of Line	112

Product Details

Fabric-Covered Panel Skins	118
Steel Panel Skins	120
Markerboard Surfaces for Steel Skins	124
Markerboard Skins	125
Slatwall Skins	126
Laminate Skins	128
Wood Skins and Wood Skin Sets	130
Back Painted Glass Skins	131
Technology Skins and Covers	132
Glass Windows	134
Sliding Panel Doors	136
Panel and Beam Foot	138
Stability Guidelines	140

Statement of Line

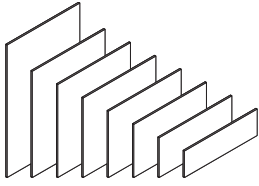

Understanding
 ▶ Page 118
 Specifying
 ▶ Pages 436–440

Tackable Acoustical Fabric-Covered Panel Skins

	18"W	24"W	30"W	36"W	42"W	48"W	60"W	72"W
12"H	●	●	●	●	●	●	●	●
18"H	●	●	●	●	●	●	●	●
19 ³ / ₁₆ "H	●B	●B	●B	●B	●B	●B	●B	●B
24"H	●F	●F	●F	●F	●F	●F	●F	●F
30"H	●F	●F	●F	●F	●F	●F	●F	●F
36"H	●F	●F	●F	●F	●F	●F	●F	●F
42"H	●F	●F	●F	●F	●F	●F	●F	●F
48"H	●F	●F	●F	●F	●F	●F	●F	●F
60"H	●F	●F	●F	●F	●F	●F	●F	●

B = Big open base sizes
F = To the floor sizes

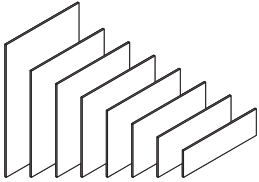

Understanding
 ▶ Page 118
 Specifying
 ▶ Pages 436–440

Performance Tackable Acoustical Fabric-Covered Panel Skins

	18"W	24"W	30"W	36"W	42"W	48"W	60"W	72"W
12"H	●	●	●	●	●	●	●	●
18"H	●	●	●	●	●	●	●	●
24"H	●F	●F	●F	●F	●F	●F	●F	●F
30"H	●F	●F	●F	●F	●F	●F	●F	●F
36"H	●F	●F	●F	●F	●F	●F	●F	●F
42"H	●F	●F	●F	●F	●F	●F	●F	●F
48"H	●F	●F	●F	●F	●F	●F	●F	●F
60"H	●F	●F	●F	●F	●F	●F	●F	●

F = To the floor sizes

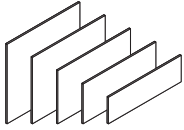

Note: 12"H, 18"H, and 24"H steel skins are available with ribbed and perforated steel option.

Understanding
 ▶ Page 120
 Specifying
 ▶ Pages 442–446

Steel Panel Skins

	18"W	24"W	30"W	36"W	42"W	48"W	60"W	72"W
12"H	●	●	●	●	●	●	●	●
18"H	●	●	●	●	●	●	●	●
19 ³ / ₁₆ "H	●B	●B	●B	●B	●B	●B	●B	●B
24"H	●F	●F	●F	●F	●F	●F	●F	●F
30"H	●F	●F	●F	●F	●F	●F	●F	●F
36"H	●F	●F	●F	●F	●F	●F	●F	●F

B = Big open base sizes
F = To the floor sizes

Tip: Ribbed and perforated steel option not available on to the floor size skins or big open base size skins.

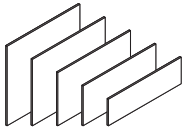

Understanding
 ▶ Page 124
 Specifying
 ▶ Page 447

Modular Markerboard Surfaces for Steel Skins

	24"W	30"W	36"W	42"W	48"W
12"H	●	●	●	●	●
24"H	●	●	●	●	●
36"H	●	●	●	●	●

Tip: Available in parametric sizes ranging from 12"W to 96"W and 12"H to 36"H.

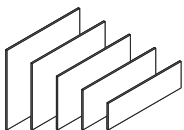

Understanding
 ▶ Page 125
 Specifying
 ▶ Pages 448–449

Markerboard Skins

	18"W	24"W	30"W	36"W	42"W	48"W	60"W	72"W
12"H	●	●	●	●	●	●	●	●
18"H	●	●	●	●	●	●	●	●
24"H	●F	●F	●F	●F	●F	●F	●F	●F
30"H	●F	●F	●F	●F	●F	●F	●F	●F
36"H	●F	●F	●F	●F	●F	●F	●F	●F

F = To the floor sizes

Statement of Line, continued

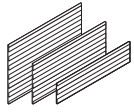

Understanding
 ▶ Page 126
 Specifying
 ▶ Page 450

Slatwall Skins

	24"W	30"W	36"W	42"W	48"W
12"H	●	●	●	●	●
18"H	●	●	●	●	●
24"H	●	●	●	●	●

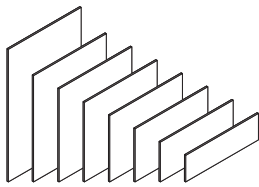

Understanding
 ▶ Page 128
 Specifying
 ▶ Pages 452–453

Laminate Skins

	24"W	30"W	36"W	42"W	48"W
12"H	●	●	●	●	●
18"H	●	●	●	●	●
24"H	●F	●F	●F	●F	●F
30"H	●F	●F	●F	●F	●F
36"H	●F	●F	●F	●F	●F
42"H	●F	●F	●F	●F	●F
48"H	●F	●F	●F	●F	●F
60"H	●F	●F	●F	●F	●F

F = To the floor sizes

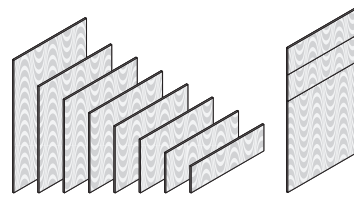

Understanding
 ▶ Page 130
 Specifying
 ▶ Pages 454–462

Wood Skins and Wood Skin Sets

	24"W	30"W	36"W	42"W	48"W
12"H	●	●	●	●	●
18"H	●	●	●	●	●
24"H	●F	●F	●F	●F	●F
30"H	●F	●F	●F	●F	●F
36"H	●SF	●SF	●SF	●SF	●SF
42"H	●SF	●SF	●SF	●SF	●SF
48"H	●SF	●SF	●SF	●SF	●SF
60"H	●SF	●SF	●SF	●SF	●SF

S = Wood skin sets

F = To the floor sizes

Tip: Wood skin sets are available for 42", 48", 54", and 66" panel heights.

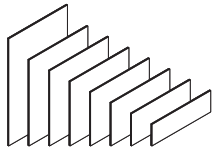

Understanding
 ▶ Page 131
 Specifying
 ▶ Pages 466–468

Back Painted Glass Skins

	18"W	24"W	30"W	36"W	42"W	48"W	60"W	72"W
12"H	●	●	●	●	●	●	●	●
18"H	●	●	●	●	●	●	●	●
24"H	●F	●F	●F	●F	●F	●F	●F	●F
30"H	●F	●F	●F	●F	●F	●F	●F	●F
36"H	●F	●F	●F	●F	●F	●F	●F	●F

F = To the floor sizes

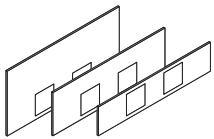

Understanding
 ▶ Page 132
 Specifying
 ▶ Page 470

Steel Technology Skins

	24"W	30"W	36"W	42"W	48"W	60"W	72"W
6"H	●	●	●	●	●	●	●
12"H	●	●	●	●	●	●	●
18"H	●	●	●	●	●	●	●

Tip: 12"H and 18"H technology skins are available with ribbed steel.
 Tip: Technology skins are available with fabric-covered option.

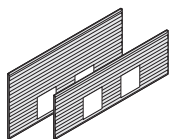

Understanding
 ▶ Page 132
 Specifying
 ▶ Page 472

Slatwall Technology Skins

	24"	30"	36"	42"	48"
12"	●	●	●	●	●
18"	●	●	●	●	●

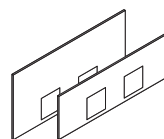

Understanding
 ▶ Page 132
 Specifying
 ▶ Page 473

Markerboard Technology Skins

	24"	30"	36"	42"	48"
12"	●	●	●	●	●
18"	●	●	●	●	●

Shared Components

Statement of Line, continued

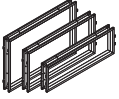

Understanding
 ▶ Page 134
 Specifying
 ▶ Pages 475 and 476

Glass Windows—Single Pane and Single Pane Kits for use with Custom Glass

	24"W	30"W	36"W	42"W	48"W	60"W	72"W	78"W	84"W	90"W	96"W
12"H	●	●	●	●	●	●	●	●	●	●	●
18"H	●	●	●	●	●	●	●	●	●	●	●
24"H	●	●	●	●	●	●	●	●	●	●	●

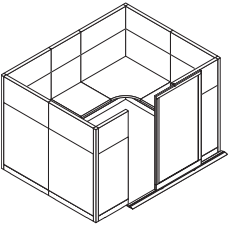

Understanding
 ▶ Page 136
 Specifying
 ▶ Page 478

Sliding Panel Door

	36"W	42"W
66"H	●	●
78"H	●	●

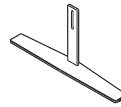

Understanding
 ▶ Page 138
 Specifying
 ▶ Page 480

Panel and Beam Foot

	21"L

Fabric-Covered Panel Skins

Performance Tackable Acoustical Fabric-Covered Skins and Tackable Acoustical Fabric-Covered Skins

Performance tackable acoustical fabric-covered skins and tackable acoustical fabric-covered skins finish the appearance of a panel. Skin combinations can vary to accommodate a variety of appearances and functions of the workspace. *Note: A sound-blocking barrier is added to the back side of the performance tackable acoustical skins.*

- ▶ Specifying, page 436
- Tip: When specifying skins, the total skin height will be 6" less than the panel height. For example if the panel is 54"H the total skin height will be 48"H. Skins to the floor are indicated by an F suffix. Plan 6" shorter than panel height, but skins to the floor are taller in actual height to cover the base trim area.*
- ▶ See Panel Buildups, page 18, for more information.

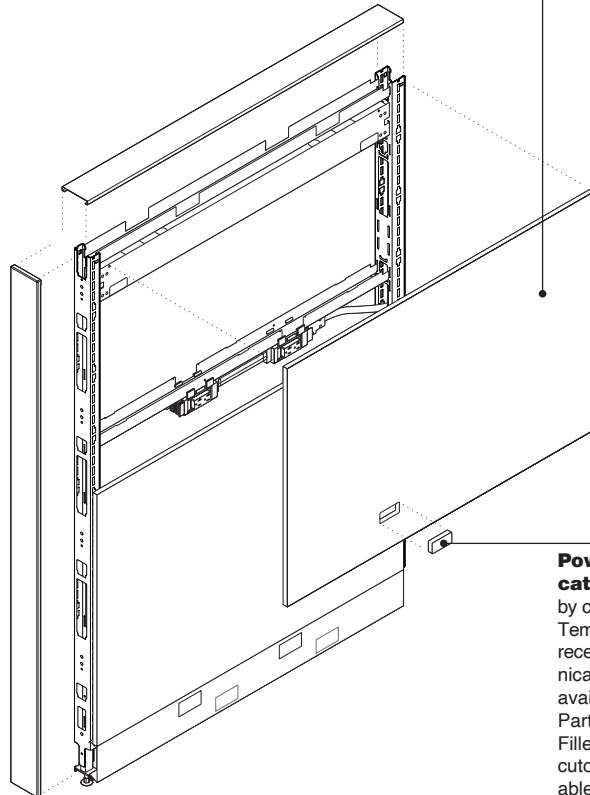

Fabric skins can be removed and repositioned.

Power and communication can be accessed by cutting skin in the field. Templates for cutting both receptacle and communication cutouts are available from Service Parts (**T500940SR**). Filler to close unwanted cutout in a skin is available from Service Parts (**TS7STFSR**).

Connections

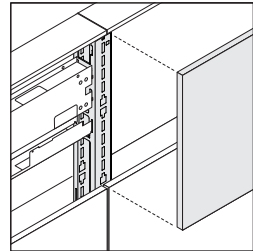

Skins extend onto junction and meet skin of adjacent panel. The slotted channel of the junction is accessible between these two skins.

Skins are available in standard heights, to the floor heights, and a big open base height. Standard height skins are not dedicated to a specific location.

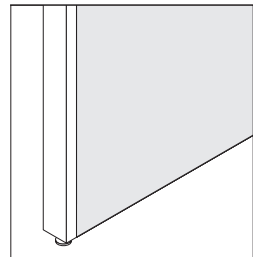

Skins sized to go to the floor extend to the bottom of the panel. They can be used on one or both sides of the panel. They can only be used in the bottom position. *Tip: Omit base trim option should be selected on the panel frame when using a skin to the floor.*

Actual Dimensions

Width	17 ⁵³ / ₆₄ ", 23 ⁵³ / ₆₄ ", 29 ⁵³ / ₆₄ ", 35 ⁵³ / ₆₄ ", 41 ⁵³ / ₆₄ ", 47 ⁵³ / ₆₄ ", 59 ⁵³ / ₆₄ ", and 71 ⁵³ / ₆₄ "
Height Standard Size	12 ²³ / ₆₄ ", 18 ⁷ / ₁₆ ", 24 ³ / ₄ ", 30 ¹³ / ₁₆ ", 37 ⁵ / ₆₄ ", 43 ¹ / ₄ ", 49 ⁷ / ₁₆ ", and 61 ¹³ / ₁₆ "
Height to the Floor Size	28 ³³ / ₆₄ ", 34 ⁵ / ₈ ", 40 ⁷ / ₈ ", 42", 47 ¹ / ₁₆ ", 53 ¹⁵ / ₆₄ ", and 65 ¹⁹ / ₃₂ "
Height for Big Open Base Size	19 ³ / ₁₆ "

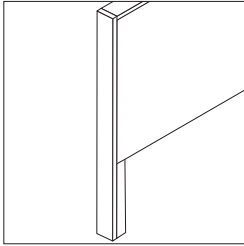

Big open base skins are sized to work in conjunction with big open base trims, leaving the bottom of the panel open. They must be used on both sides of a panel.

Tip: Select the big open base option on horizontal frames that are receiving big open base height skins.

Tackable acoustical skins are available in big open base sizes. Performance tackable skins are not available in big open base sizes.

Wiring & Cabling

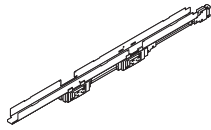

Powerkits are available in widths that correspond to panel widths.

Faceplate is used to surround receptacle when field-cutting fabric skins.

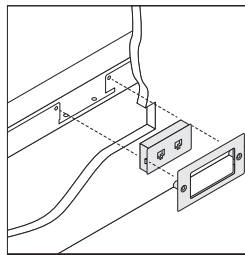

Faceplate, ordered separately, is used to surround modular furniture size communication outlet when field-cutting fabric skins.

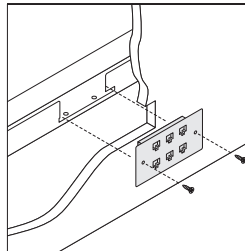

NEMA-size communication outlets can be installed on the face of a panel skin without using a faceplate, but just the screws. Order communication outlets from an outside vendor. NEMA-size communication outlets cannot be used in the base.

Surface Materials

Skins
• Fabric

Fabric application is standard in the warp horizontal direction. Warp vertical direction is available as an option. Exceptions to this include:

- 72" wide standard and to the floor skins can only accommodate fabric in the horizontal direction.
- 60" high to the floor skins can only accommodate fabric in the vertical direction.
- 48" high to the floor skins accommodate select fabrics in the vertical direction only.

▶ See *Specification Guidelines for Directional Fabrics*, page 674, for more information.

Application Topics

Panel buildups

▶ Page 18

Big open base skins are 19³/₁₆"H and placed on the junctions just above the big open base vertical trim.

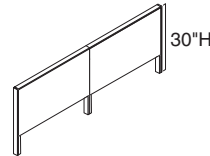

Big open base skins are sized to finish a 30"H panel.

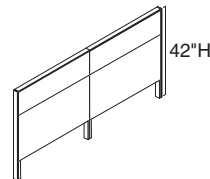

Big open base skins can be added to panels taller than 30"H. Standard sized skins are used to finish the remaining panel height. For example a 42"H panel with big open base will need a big open base skin and a 12"H skin on each side of the panel.

Steel Panel Skins

Steel panel skins finish the appearance of a panel. Skin combinations can vary to accommodate a variety of appearances and functions of the workspace.

► Specifying, page 442

Tip: When specifying skins, the total skin height will be 6" less than the panel height. For example if the panel is 54"H the total skin height will be 48"H. Skins to the floor are indicated by an F suffix. Plan 6" shorter than panel height, but skins to the floor are taller in actual height to cover the base trim area.

► See Panel Buildups, page 18, for more information.

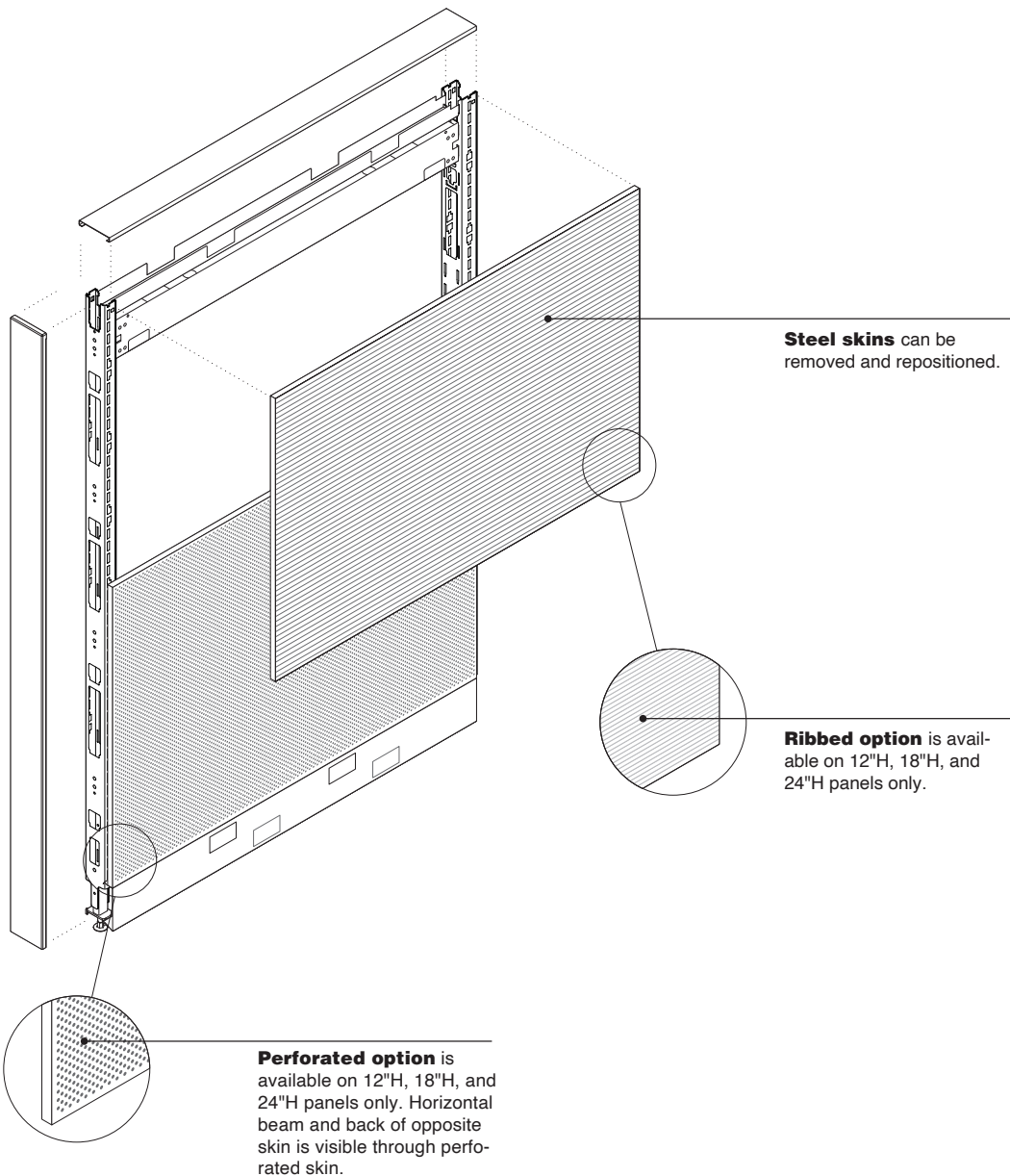

Actual Dimensions

Width 17⁵³/₆₄", 23⁵³/₆₄", 29⁵³/₆₄", 35⁵³/₆₄", 41⁵³/₆₄", 47⁵³/₆₄", 59⁵³/₆₄", and 71⁵³/₆₄"

Height 12⁹/₃₂", 18⁷/₁₆", 24⁴/₆₄", 30¹³/₁₆", and 37"

Height to the Floor Size 28²⁹/₆₄", 34⁵/₈", and 40¹³/₁₆"

Height for Big Open Base Size 19³/₁₆"

Connections

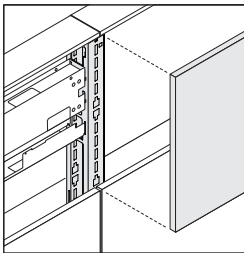

Skins extend onto junction and meet skin of adjacent panel. The slotted channel of the junction is accessible between these two skins.

Skins are available in standard heights, to the floor heights, and a big open base height. Standard height skins are not dedicated to a specific location.

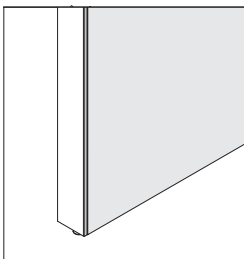

Skins sized to go to the floor extend to the bottom of the panel. They can be used on one or both sides of the panel. They can only be used in the bottom position.

Tip: Omit base trim option should be selected on the panel frame when using a skin to the floor.

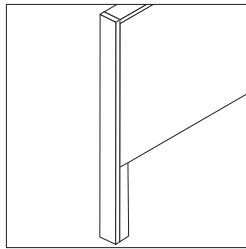

Big open base skins are sized to work in conjunction with big open base trims, leaving the bottom of the panel open. They must be used on both sides of a panel.

Tip: Select the big open base option on horizontal frames that are receiving big open base height skins.

Wiring & Cabling

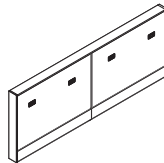

Power and data can be accessed in 24"H standard base, 24"H to the floor, and big open base steel skins by specifying power and data cutouts.

Steel skins with power and data cutouts are placed in the lowest skin position on the panel and provide power access at 20".

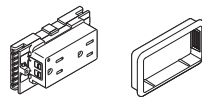

For power access in steel skins, specify **TS7RC** receptacles and **TS7RCT** trim rings for each cutout.

Receptacle fillers are available to fill unused receptacle openings in steel skins. Use **TSBRF**.

Data fillers are available to fill unused furniture style data openings. Use **TS7DF**.

For 24"W and 30"W steel skins, hardwire receptacle cutout option will always have a single centered hardwire cutout.

For 36"W and wider steel skins, hardwire receptacle cutout option will always come with a left and right hardwire cutout.

Data cutouts are available in furniture style data cutouts and NEMA data cutouts.

For USB power access in steel skins, specify **TS7USB** receptacles and **TS7RCT** trim rings for each cutout.

Surface Materials

Skins

- Painted steel
- Ribbed steel (option)
- Perforated steel (option)

Application Topics

Panel buildups

▶ Page 18

Horizontal connecting bars will be visible when perforated skins are used on the panel.

When specifying the perforated option, order perforated skins for both sides of the panel to maximize the visual aesthetic.

Perforated skins cannot be used in installation with steel or ribbed steel skins made prior to July 10, 2000.

Big open base skins are 19³/₁₆"H and are placed on the junctions just above the big open base vertical trim.

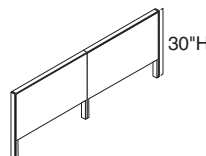

Big open base skins are sized to finish a 30"H panel.

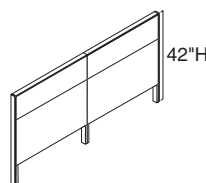

Big open base skins can be added to panels taller than 30"H. Standard sized skins are used to finish the remaining panel height. For example a 42"H panel with big open base will need a big open base skin and a 12"H skin on each side of the panel.

Steel Panel Skins, continued

Application Topics, continued

Steel skins with modular power cutouts are available in the following cutout configurations.

24"W steel skins are available in the following modular power and data cutout configurations:

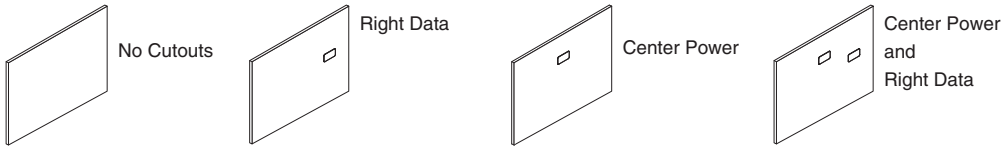

30"W steel skins are available in the following modular power and data cutout configurations:

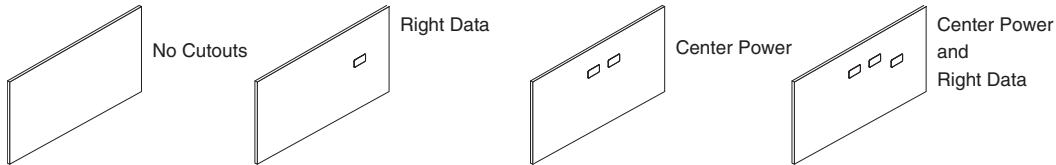

36"W steel skins are available in the following modular power and data cutout configurations:

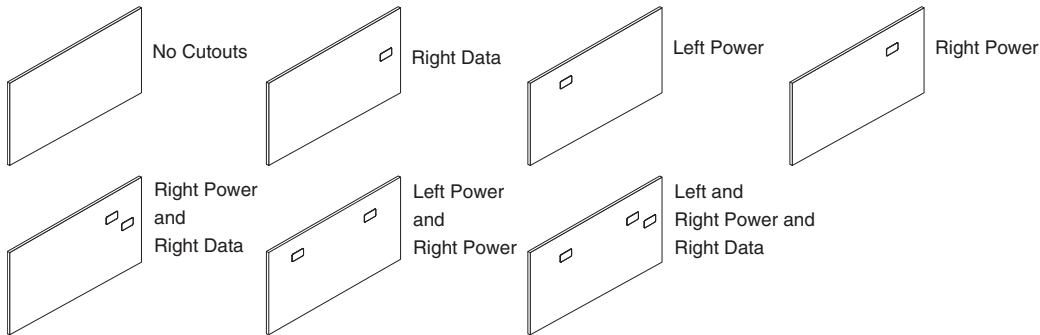

42"W and 48"W steel skins are available in the following modular power and data cutout configurations:

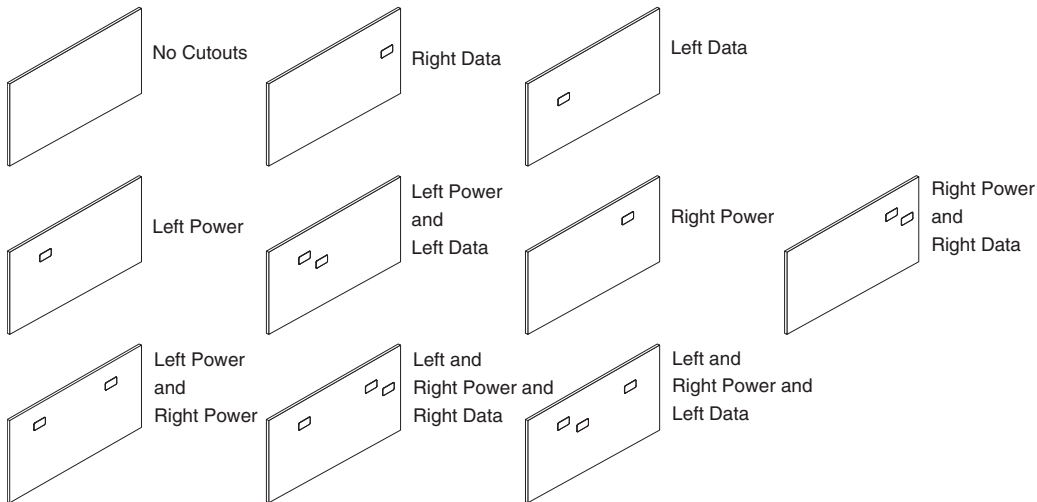

Application Topics, continued

60"W and 72"W steel skins are available in the following modular power and data cutout configurations:

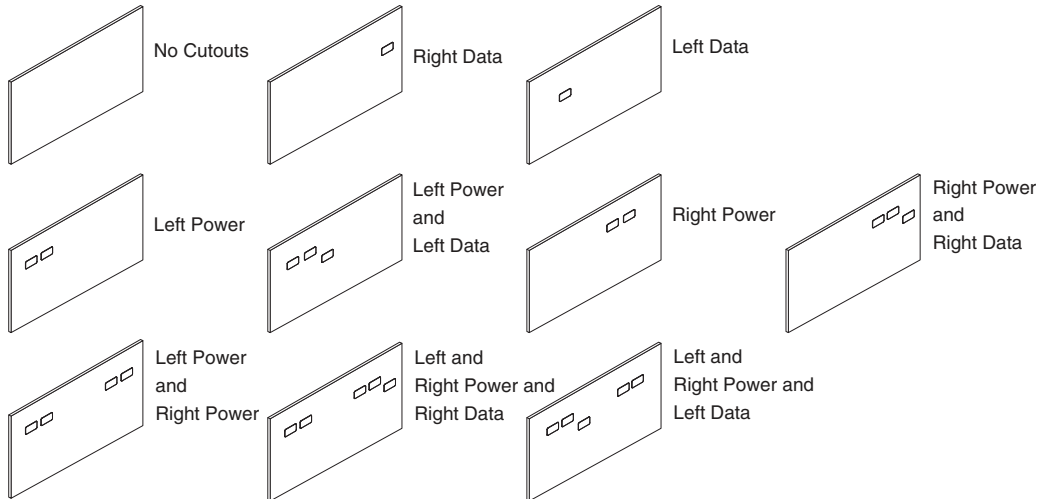

Steel skins with hardwire power cutouts are available in the following cutout configurations.

24"W and 30"W steel skins are available in the following hardwire power and data cutout configurations:

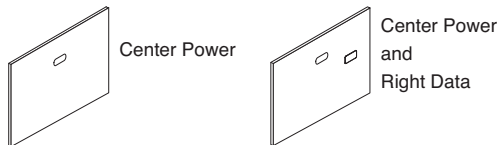

36"W steel skins are available in the following power and data cutout configurations:

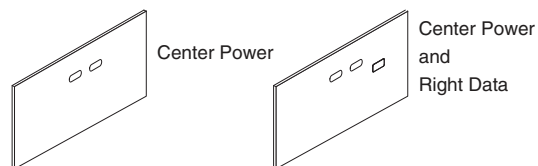

42", 48", 60", 72"W steel skins are available in the following power and data cutout configurations:

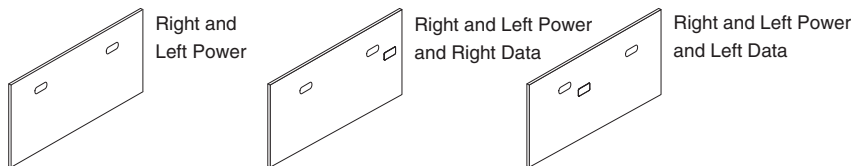

Markerboard Surfaces for Steel Skins

Markerboard surface

adheres to steel skins to provide a writing surface for dry erase markers.

► Specifying, page 447

Magnetic border on back of markerboard affixes to steel skin. Markerboard surface can be removed and repositioned.

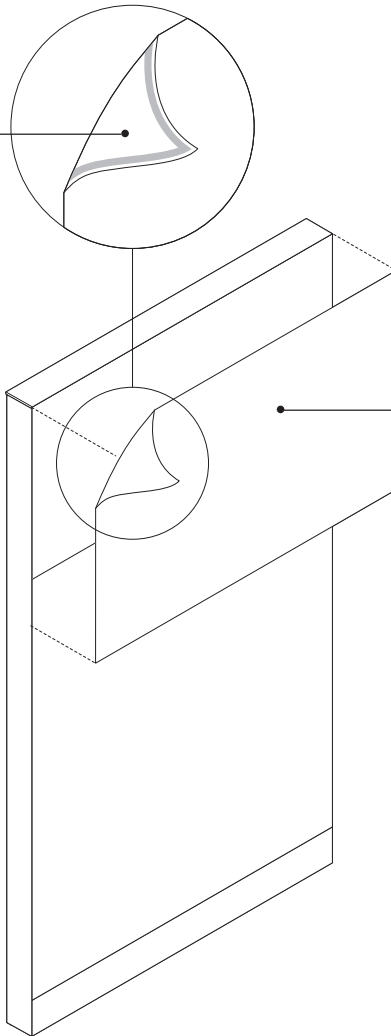

Write on markerboard surface with dry erase markers only.

Product Details

Not for use on steel panels with the ribbed surface.

For best adhesive performance, place magnetic markerboard on skin with the largest dimension horizontal.

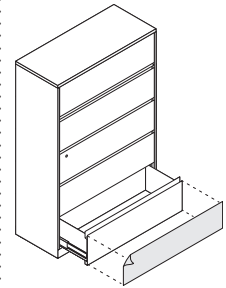

Markerboard surface, can adhere to additional steel products such as universal steel storage.

Surface Materials

- **Markerboard**
- White only

Actual Dimensions

Width 23⁴⁵/₆₄" , 29⁴⁵/₆₄" , 35⁴⁵/₆₄" , 41⁴⁵/₆₄" , and 47⁴⁵/₆₄"

Height 12⁵/₃₂" , 24¹/₂" , and 36⁷/₈"

Note: Markerboard heights and widths can also be specified parametrically.

Markerboard Skins

Markerboard skins finish the appearance of a panel and provide a writing surface for dry erase markers.

Tip: When ordering skins to the floor an F suffix will be added to the end of the style number. The total height will still be 6" less than the panel height. Using the same example, if the panel is 54"H, 48" of skin height will need to be specified.

► Specifying, page 448

Markerboard skins can be removed and repositioned. They are not dedicated to a specific location.

Skin is steel construction and can accept magnets to display and share information.

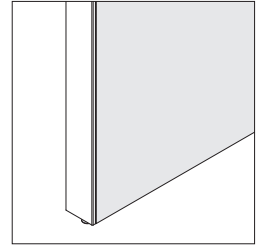
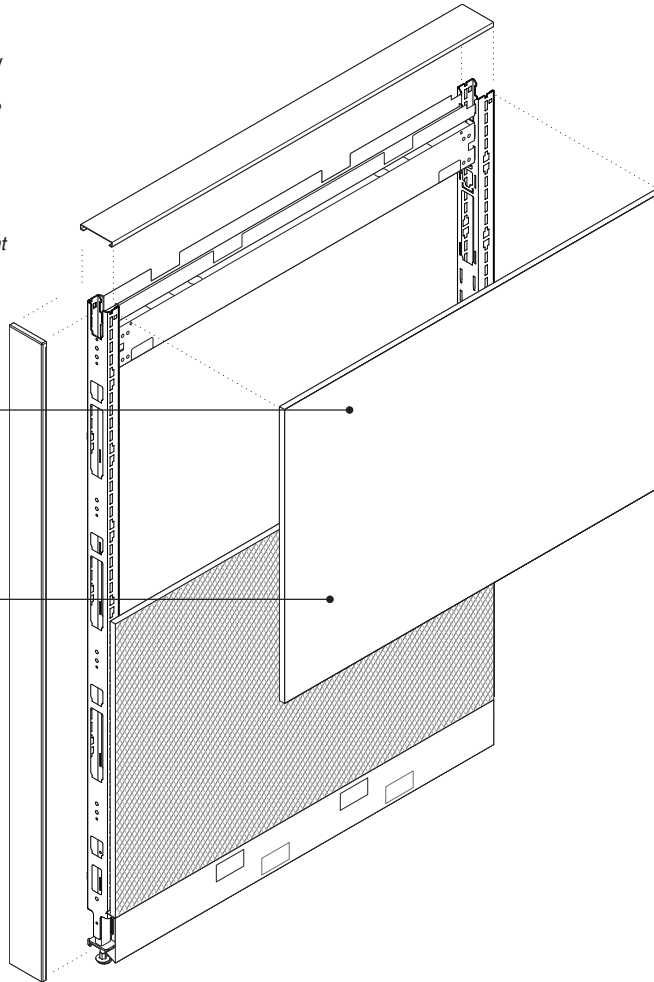

Skins sized to go to the floor extend to the bottom of the panel. They can be used on one or both sides of the panel. They can only be used in the bottom position.

Tip: Omit base trim option should be selected on the panel frame when using a skin to the floor.

Wiring & Cabling

Power and communication cannot be accessed in markerboard skins.

Surface Materials

Markerboard skin

- White only

Application Topics

Panel buildups

► Page 18

Cleaning Instructions for Answer Markerboard Skins

1. Use clean dry eraser or microfiber cloth to remove as much ink as possible.
2. Use Expo cleaner or other markerboard cleaner with microfiber cloth. If the markerboards are used daily, cleaning may be required 2-3 times a week.
3. For heavily used boards and persistent markings, clean with 91% Isopropyl Alcohol (IPA) on a microfiber cloth. It is recommended that the markerboard skins be cleaned with 91% IPA once a week.

Note: Use of household cleaners on Answer markerboard skins is not recommended.

Connections

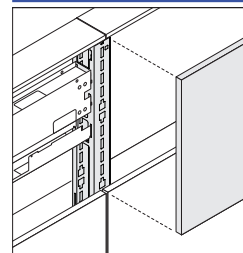

Skins extend onto junction and meet skin of adjacent panel. The slotted channel of the junction is accessible between these two skins.

Actual Dimensions

Width 17⁵³/₆₄", 23⁵³/₆₄", 29⁵³/₆₄", 35⁵³/₆₄", 41⁵³/₆₄", 47⁵³/₆₄", 59⁵³/₆₄", and 71⁵³/₆₄"

Height 12⁹/₃₂", 18⁷/₁₆", 24¹/₆₄", 30¹³/₁₆", and 37"

Height to the Floor Size 28²⁹/₆₄", 34⁵/₈", and 40¹³/₁₆"

Slatwall Skins

Slatwall skins have horizontal channels that support Steelcase worktools and accessories on 1" increments. Maximum load on skin is 80 pounds.
 ▶ Specifying, page 450

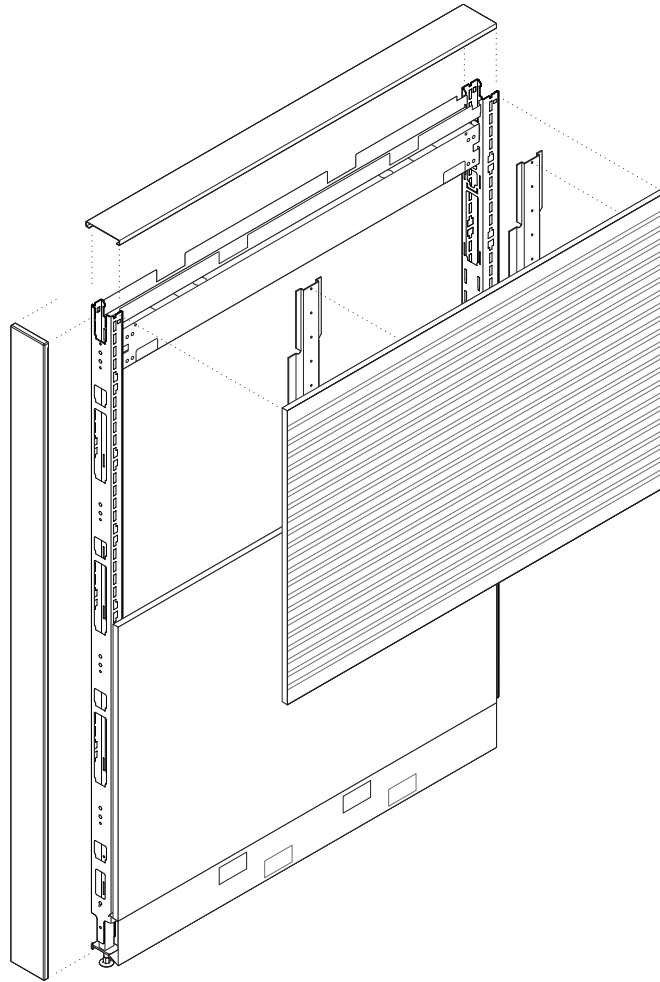

Product Details

Slatwall skins can be removed and repositioned. They are not dedicated to a specific location.

Wiring & Cabling

Power and cables cannot be accessed in a slatwall skin.

Back-to-back slatwall skins cannot be installed at the top of a panel when using a ceiling access lay-in utility package.

Surface Materials

- Paint

Application Topics

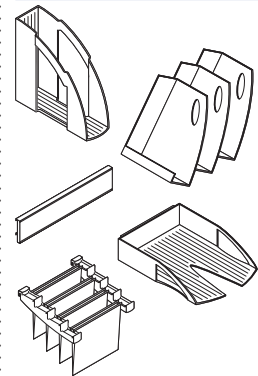

Accessories are available for use on slatwall skins.

▶ For additional information, refer to *Steelcase Worktools Specification Guide*.

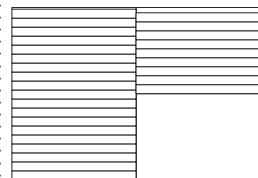

Slatwall channels will not align when the top of a 12"H slatwall skin is adjacent to the top of an 18"H or 24"H slatwall skin.

Actual Dimensions

Width 23¹³/₁₆" , 29¹³/₁₆" , 35¹³/₁₆" , 41¹³/₁₆" , and 47¹³/₁₆"

Height 12⁵/₁₆" , 18¹/₂" , and 24¹¹/₁₆"

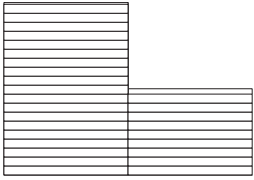

Slatwall channels will align when the bottom of a 12"H slatwall skin is adjacent to the bottom of an 18"H or 24"H slatwall skin.

Binder bin or shelf can be hung in front of a slatwall skin. If two bins or shelves are hung side-by-side in front of slatwall skins, the top hook must use either the third or fourth full slot down from the top. The first and second full slots from the top will not accept side-by-side shelves.

Binder bin or shelf can be upmounted on slatwall skin as long as there is not another bin or another slatwall skin on the adjacent in-line panel.

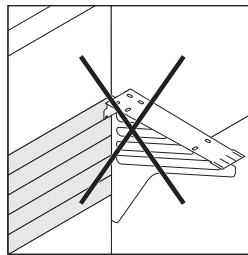

Slatwall skins cannot be hung next to a cantilever or on module end panel.

Slatwall skins cannot be used in the bottom 12" of an Answer panel.

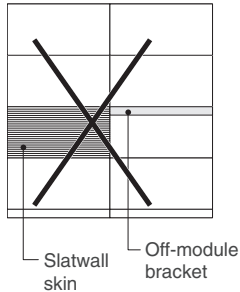
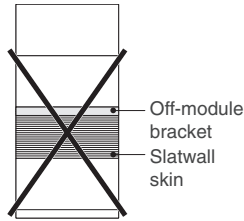

Off-module work surface to panel connector cannot be used in front of or on the adjacent panel at the same elevation as a 12"H or 24"H slatwall skin.

Slatwall skin brace package is required when mounting a flat panel monitor arm on an Answer slatwall skin.

One single or dual monitor arm can be mounted on 12"H slatwall skin that has an installed brace package.

Up to two single monitor arms can be mounted on 18"H or 24"H Answer slatwall skin that has an installed brace package. For optimal stability, the monitor arm should be mounted as shown below:

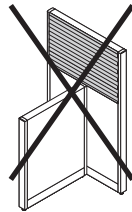
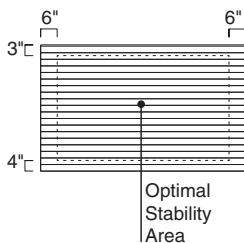

Slatwall skins cannot be placed on the spine panel when an off-module fin panel is positioned below it.

Laminate Skins

Laminate skins attach to frames to finish the appearance of a panel and can be used in combination with any other skin type.

► Specifying, page 452

Tip: When specifying skins, the total skin height will be 6" less than the panel height. For example if the panel is 54"H the total skin height will be 48"H. Skins to the floor are indicated by an F suffix. Plan 6" shorter than panel height, but are taller in actual height to cover the base trim area.

► See *Panel Buildups*, page 18, for more information.

Laminate skins consist of a laminate surface captured by a painted metal trim border on all sides.

Laminate skins are non-tackable.

Skins can be removed and repositioned.

Individual laminate skins are available for use in monolithic applications or in combination with other types of skins on the same frame.

Connections

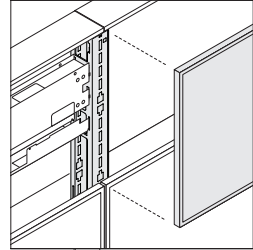

Skins extend onto junction and meet skin of adjacent panel. The slotted channel of the junction is accessible between these two skins.

Skins are available in standard heights and to the floor heights.

Standard heights are not dedicated to a specific location.

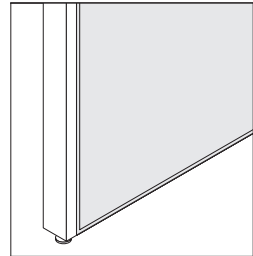

Skins sized to go to the floor extend to the bottom of the panel. They can be used on one or both sides of the panel. They can only be used in the bottom position.

Tip: Omit base trim option should be selected on the panel frame when using a skin to the floor.

Actual Dimensions

Width	23 ⁵³ / ₆₄ " , 29 ⁵³ / ₆₄ " , 35 ⁵³ / ₆₄ " , 41 ⁵³ / ₆₄ " , and 47 ⁵³ / ₆₄ "
Height Standard Size	127 ³² / ₃₂ " , 18 ³ / ₈ " , 24 ³⁷ / ₆₄ " , 30 ³ / ₄ " , 36 ¹⁵ / ₁₆ " , 43 ¹ / ₈ " , 49 ¹⁹ / ₆₄ " , and 61 ²¹ / ₃₂ "
Height to the Floor Size	28 ²⁷ / ₆₄ " , 34 ⁵ / ₈ " , 40 ²⁵ / ₃₂ " , 47" , 53 ⁹ / ₆₄ " , and 65 ¹ / ₂ "

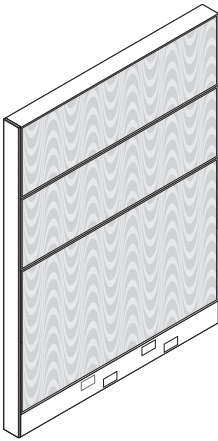

Woodgrain and directional laminate patterns run vertical as standard with an option of running horizontally.
Tip: All 60"H skins are only available in vertical direction for woodgrain and directional laminates.

Grain direction pattern may not align on segmented laminate skins on a single frame.

Wiring & Cabling

Power and communication cannot be accessed in laminate skins.

Surface Materials

- Laminate skins**
- Laminate (standard)
 - Open Line laminate (option)

- Trim**
- Paint

Wood Skins and Wood Skin Sets

Wood skins and wood skin sets attach to frames

to finish the appearance of a panel and can be used in combination with any other skin type.

► Specifying, page 454

Tip: When specifying skins, the total skin height will be 6" less than the panel height. For example if the panel is 54"H the total skin height will be 48"H. Skins to the floor are indicated by an F suffix. Plan 6" shorter than panel height, but skins to the floor are taller in actual height to cover the base trim area.

► See Panel Buildups, page 18, for more information.

Wood skin sets contain specific combinations of sizes and are used when segmenting all wood skins on 42"H, 48"H, 54"H, or 66"H panels. The use of sets ensures the correct cathedral wood grain alignment of all segmented skins on a frame.

Wood skins consist of a wood veneer surface captured by a painted metal trim border on all sides.

Connections

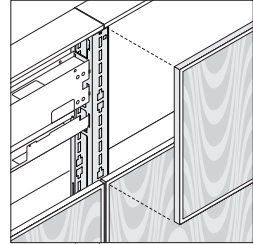

Skins extend onto junction and meet skin of adjacent panel. The slotted channel of the junction is accessible between these two skins.

Skins are available in standard heights and to the floor heights.

Standard heights are not dedicated to a specific location.

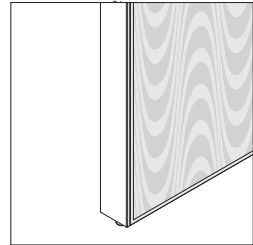

Skins sized to go to the floor extend to the bottom of the panel. They can be used on one or both sides of the panel. They can only be used in the bottom position.

Tip: Omit base trim option should be selected on the panel frame when using a skin to the floor.

Wood skin sets should be selected when grain pattern alignment of all segmented skins on a frame is desired.

Wiring & Cabling

Power and communication cannot be accessed in wood skins.

Surface Materials

Wood skins and wood skin sets

- Natural wood veneer (standard)
- Custom stain (option)

Trim

- Paint

Wood skins are non-tackable.

Skins can be removed and repositioned.

Grain of wood veneer cathedrals runs vertically. Horizontal grain direction is available as an option.

Individual wood skins are available for use in monolithic applications or in combination with other types of skins on the same frame.

Actual Dimensions

Width	23 ⁵³ / ₆₄ " , 29 ⁵³ / ₆₄ " , 35 ⁵³ / ₆₄ " , 41 ⁵³ / ₆₄ " , and 47 ⁵³ / ₆₄ "
Height Standard Size	12 ⁷ / ₃₂ " , 18 ³ / ₈ " , 24 ³⁷ / ₆₄ " , 30 ³ / ₄ " , 36 ¹⁵ / ₁₆ " , 43 ¹ / ₈ " , 49 ¹⁹ / ₆₄ " , and 61 ²¹ / ₃₂ "
Height to the Floor	28 ²⁷ / ₆₄ " , 34 ⁵ / ₈ " , 40 ²⁵ / ₃₂ " , 47" , 53 ⁹ / ₆₄ " , and 65 ¹ / ₂ "

Back Painted Glass Skins

Back painted glass skins attach to frames to finish the appearance of a panel and can be used in combination with any other skin type.

- ▶ Specifying, page 466

Tip: When specifying skins, the total skin height will be 6" less than the panel height. For example, if the panel is 42"H the total skin height will be 36"H. Skins to the floor are indicated by an F suffix. Plan 6" shorter than panel height, but skins to the floor are taller in actual height to cover the base trim area.

- ▶ See *Panel Buildups*, page 18, for more information.

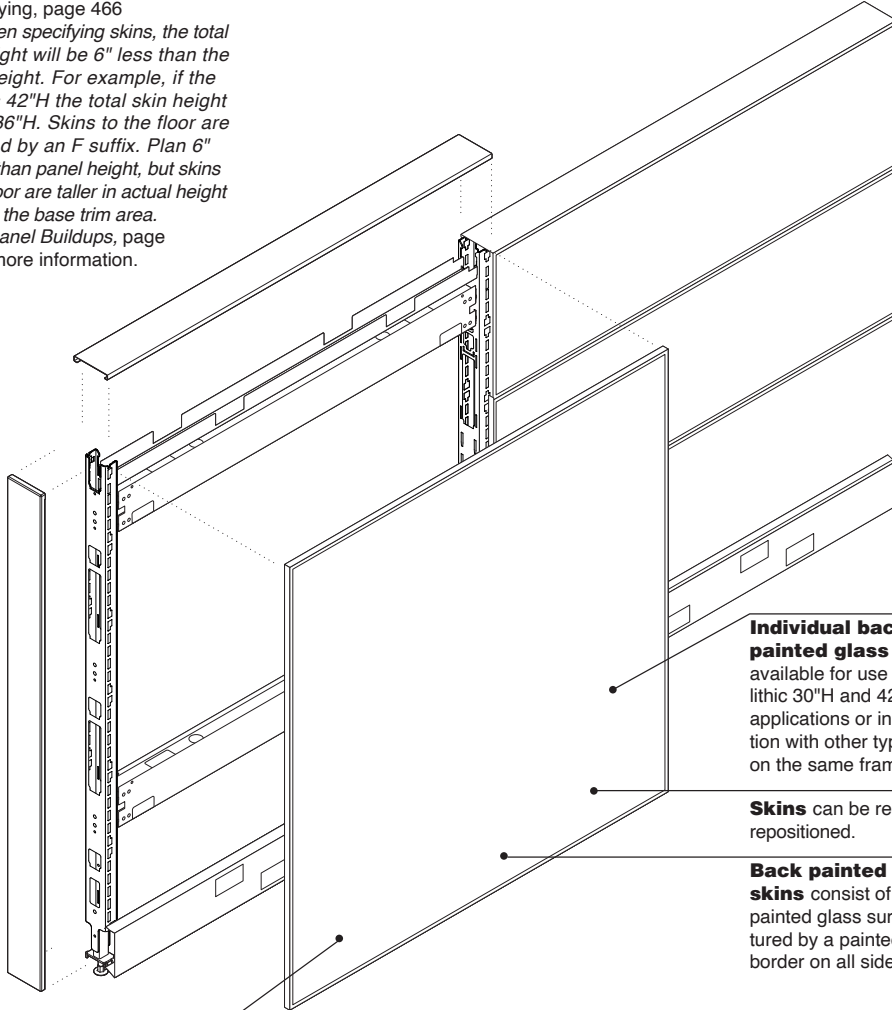

Individual back painted glass skins are available for use in monolithic 30"H and 42"H panel applications or in combination with other types of skins on the same frame.

Skins can be removed and repositioned.

Back painted glass skins consist of a back painted glass surface captured by a painted metal trim border on all sides.

Back painted glass skins are non-tackable.

Skins are available in standard heights and to the floor heights.

Standard heights are not dedicated to a specific location.

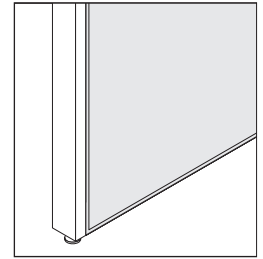

Skins sized to go to the floor extend to the bottom of the panel. They can be used on one or both sides of the panel. They can only be used in the bottom position.

Tip: Omit base trim option should be selected on the panel frame when using a skin to the floor.

Application Topics

A magnetic backer is available as an option on all skin sizes. There is a 2³/₈" dead zone around edge with magnetic backer option.

Tip: Rare earth magnets should be used with the magnetic backer.

Wiring & Cabling

Power and communication cannot be accessed in glass skins.

Surface Materials

Glass skins

- Back painted glass

Trim

- Paint

Connections

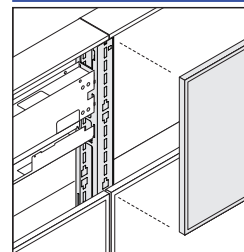

Skins extend onto junction and meet skin of adjacent panel. The slotted channel of the junction is accessible between these two skins.

Tip: Back painted glass skins do not attach to wall start junctions.

Actual Dimensions	
Width	17 ⁵³ / ₆₄ ", 23 ⁵³ / ₆₄ ", 29 ⁵³ / ₆₄ ", 35 ⁵³ / ₆₄ ", 41 ⁵³ / ₆₄ ", 47 ⁵³ / ₆₄ ", 59 ⁵³ / ₆₄ ", and 71 ⁵³ / ₆₄ "
Height Standard Size	127 ³² / ₂ ", 18 ³ / ₈ ", 24 ³⁷ / ₆₄ ", 30 ³ / ₄ ", and 36 ¹⁵ / ₁₆ "
Height to the Floor	28 ²⁷ / ₆₄ ", 34 ⁵ / ₈ ", and 40 ²⁵ / ₃₂ "

Technology Skins and Covers

Technology skin provides easy access to power and cabling behind the skin.
 ▶ Specifying, page 470

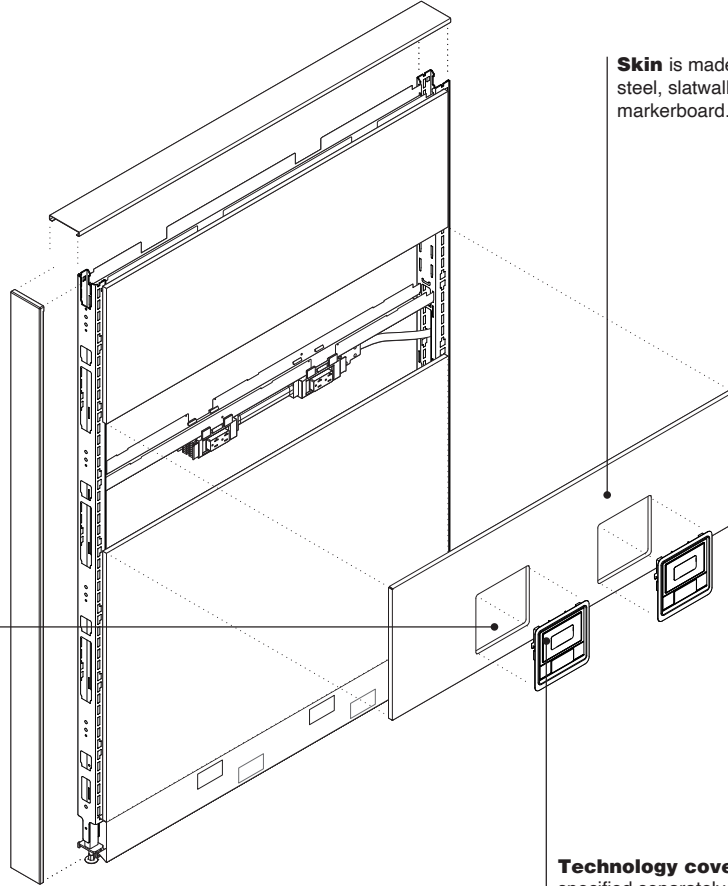

Cutout is positioned at receptacle location.

Skin is made of steel, slatwall, or markerboard.

Technology cover is specified separately and can accommodate a receptacle and a NEMA or DECORA communication port.

Product Details

Technology skins are available in 24" to 72" widths to match standard panel widths.

Technology skins are available in steel, ribbed steel, fabric over steel, slatwall, or markerboard. Not all materials are available on all skin heights or widths.

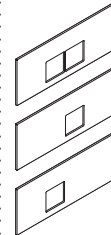

Technology skins 30" or under are available with all cutouts or with only right- or left-hand cutouts.

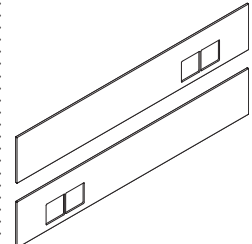

60"W and 72"W skins will have double cutouts and can be optioned to have them on both sides, right hand only or left hand only.



6"H technology skin has an option to omit all cutouts.

Slatwall technology skins include a painted trim for each cutout that is used behind the technology cover. It is painted to match the skin.

Slatwall technology skins must follow the same vertical placement rules as slatwall skins.

▶ See page 126 for Vertical Placement Rules.

Actual Dimensions

Width 23⁵³/₆₄", 29⁵³/₆₄", 35⁵³/₆₄", 41⁵³/₆₄", 47⁵³/₆₄", 59⁵³/₆₄", and 71⁵³/₆₄"

Height 6¹/₈", 12⁹/₃₂", and 18⁷/₁₆"

Thickness 1³/₃₂"

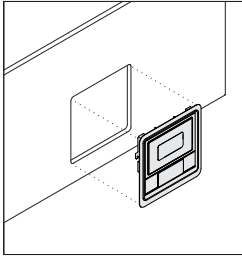

Technology cover accommodates both power only and power communication. Technology cover includes all necessary adapters and fillers needed for both applications. When expressing communication only, receptacle covers are available through Service Parts (891700204MP).

Connections

Skin attaches to junctions with the same clip used on all Answer skins.

Technology covers snap on to the powerkit after receptacle is installed.

Wiring & Cabling

Standard modular powerkits must be used with technology skins and covers. They cannot be used with hardwire kits.

Top opening of cover accommodates a NEMA or modular communication port and have been designed around ANSI/TIA-569-C standards for furniture mounted communication faceplates that snap into furniture openings or knockouts. Communication ports can never be back-to-back. Cover also includes a filler if no communication is being used.

Receptacle cover is available through Service Parts (891700204MP) to cover the receptacle opening if no receptacle is specified.

Surface Materials

Technology skins-6"H

- Painted steel
- Fabric covered steel (option)

Technology skins-12"H and 18"H

- Painted steel
- Ribbed steel (option)
- Fabric covered steel (option)
- Slatwall-painted
- Markerboard

Fabric application is standard in the warp horizontal direction. Warp vertical direction is available as an option.

▶ See *Specification Guidelines for Directional Fabrics*, page 674, for more information.

Technology covers

- 6000 Black
- 6009 Arctic White
- 6249 Platinum Solid
- 6654 Sand
- 6697 Fog

Application Topics

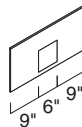

24"W skin

24"W technology skins have one cutout. Communication ports cannot be supported back to back, so in this skin width, communication can only be accommodated on one side of the panel at the same elevation.

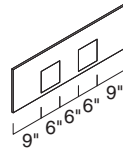

36"W skin

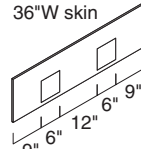

42"W skin

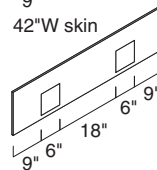

48"W skin

All 36"W, 42"W, and 48"W technology skins have one or two cutouts. The right-hand cutout can accommodate power only or power and communication. Left-hand cutout can only accommodate the power.

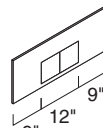

30"W skin

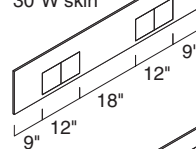

60"W skin

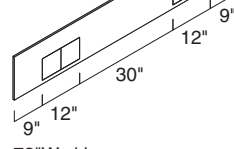

72"W skin

All 30"W, 60"W, and 72"W technology skins have one or two cutouts. For each double cutout the right-hand opening can accommodate power only or power and communication. Left-hand cutout can only accommodate the power.

Number of technology covers specified must match the number of cutouts in a skin.

If using powerkits shipped prior to April 2000 in an existing application, power and communication cover must be placed on the left-hand side of the technology skin.

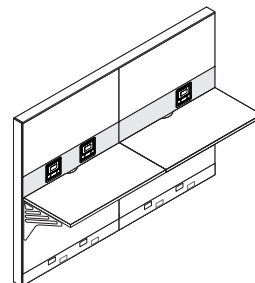

6"H technology skin can only be used in the position just above the work-surface. The skin includes powerkit brackets to be used to reposition the powerkit location on the junction.

When using a 6" technology skin on one side of the panel (only used at worksurface height) a 12" or 18" technology skin cannot be used on the opposite side of the panel at the same location as the 6"H skin.

6"H technology skins cannot be used on a 30" high panel.

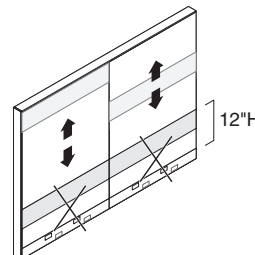

6"H technology skins with no cutouts can be used in any 6" position on the panel with the exception of the bottom 12" of the panel.

18"H technology skins must be planned in 12"H increments from the bottom of the panel to align with powerkit locations.

Slatwall technology skins must follow applicable slatwall skin vertical placement rules. ▶ See page 126 for rules.

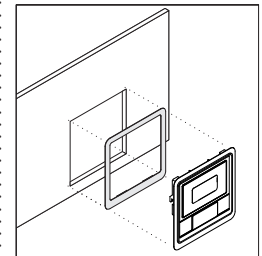

Technology skin cover fillers are available to allow technology skin cover to work with technology skins manufactured before October 10, 2011. Fillers are available for single or double cutouts and are painted.

Slatwall skin brace package is required when mounting a flat panel monitor arm on an Answer slatwall technology skin.

One single monitor arm can be mounted on a 12"H or 18"H slatwall technology skin with a single cutout. The skin must have an installed brace package. When planning location of technology skins, factor in location of height-adjustable desk to avoid interference with cords.

Glass Windows

Glass windows provide a visual space definition, yet allow light to pass through the workstation. They are available in single pane. Also available is a single pane kit that ships without glass and is used with custom glass, ordered separately.

► Specifying, page 475

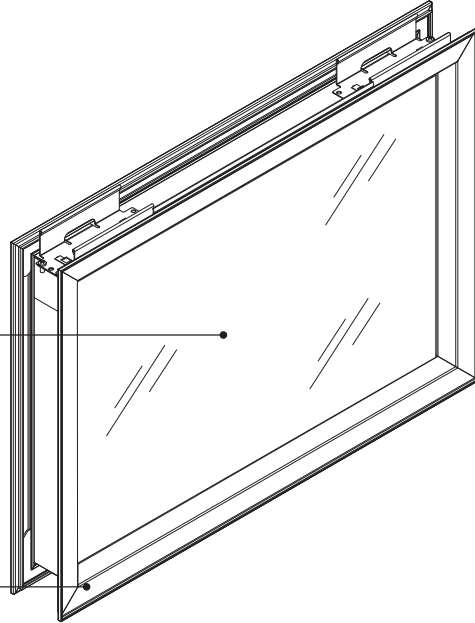

Safety glass is provided, unless custom glass window kit is ordered.

Metal frame is painted and fully assembled.

Product Details

Glass window is secured by brackets in the window frame.

Wiring & Cabling

Power and cables cannot be routed vertically or accessed in a glass window.

Top channel of a window used in the top position of a panel can accommodate lay-in cable routing beneath top cap.

Surface Materials

Frame
• Paint

Single-pane window

- 6500 Clear Glass
- 6530 Frosted Glass

Tip: Frosted glass is a laminated construction. There may be variation in color, texture, and finish between the sample of 6530 Frosted Glass and the actual product.

Application Topics

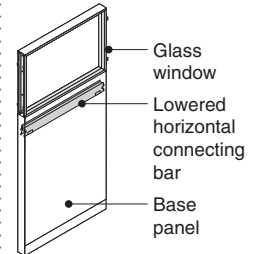
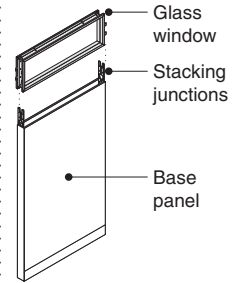

12"H, 18"H, and 24"H glass windows

can be placed in the top position of a panel by either using stacking junctions, or by lowering the top horizontal connecting bar (24" maximum) in the base panel.

► See *Stability Guidelines* for rules regarding stacking and glass windows, page 140.

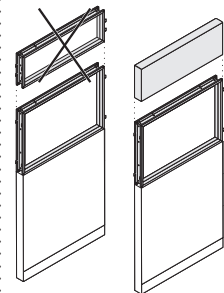

A 18"H or 24"H glass window

installed in the top of a base panel cannot accommodate any windows stacked on top. Tackable acoustical skins and steel skins can be stacked. Only 12"H glass windows can be stacked on top of each other.

Actual Dimensions

Depth	2 ⁷ / ₈ " (single pane)
Width	23 ⁵¹ / ₆₄ ", 29 ⁵¹ / ₆₄ ", 35 ⁵¹ / ₆₄ ", 41 ⁵¹ / ₆₄ ", 47 ⁵¹ / ₆₄ ", 59 ⁵¹ / ₆₄ ", 71 ⁵¹ / ₆₄ ", 77 ⁵¹ / ₆₄ ", 83 ⁵¹ / ₆₄ ", 89 ⁵¹ / ₆₄ ", and 95 ⁵¹ / ₆₄ "
Height	12 ⁹ / ₃₂ ", 18 ⁷ / ₁₆ ", and 24 ⁴¹ / ₆₄ "

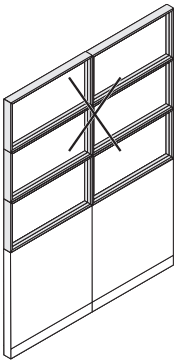

No more than two windows may be stacked on top of each other.

Glass windows cannot be placed in the top position of a panel segment that has a 6"H stacker.

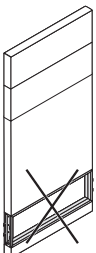

Glass window cannot be used at the base of a panel.

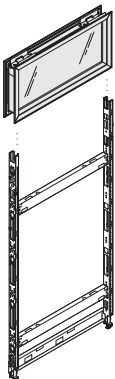

When installing windows, you must consider ceiling height. Windows slide into junctions from the top and require clearance above the panel.

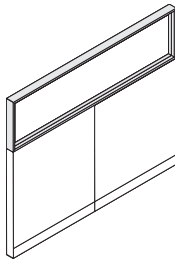

A single glass window can span over two or more in-line panels.

Spanning windows should be used in the top position only.

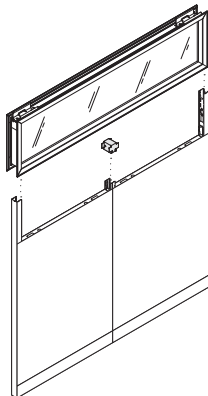

Spanning window in-line support must be specified separately when spanning windows. One support is used at each in-line junction to provide a light seal and help support the window.

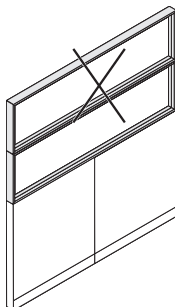

Spanning windows of any width cannot be stacked on top of each other.

When a spanning window is used, it is recommended that the same size spanning top cap also be specified for use on the window.

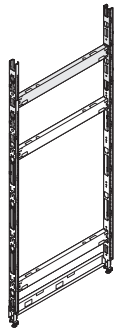

When double stacking junctions, at least one of the stacking junctions must be connected with a horizontal beam.

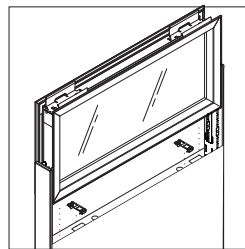

When ordering a 72"W or wider single pane window kit to be used with steel or fabric skins located directly below it, two clips (890146001SR) should be ordered and installed on the top edge of the skins.

Field-Installed, Single-Pane Custom Glass Kits will accommodate 4 mm – 6 mm glass

Frame Size	Style Number	Height	Width	Maximum Thickness
12"H	24"W TS71224SCW	9.760"	21.280"	0.245"
	30"W TS71230SCW	9.760"	27.280"	0.245"
	36"W TS71236SCW	9.760"	33.280"	0.245"
	42"W TS71242SCW	9.760"	39.280"	0.245"
	48"W TS71248SCW	9.760"	45.280"	0.245"
	60"W TS71260SCW	9.760"	57.280"	0.245"
	72"W TS71272SCW	9.760"	69.280"	0.245"
	78"W TS71278SCW	9.760"	75.280"	0.245"
	84"W TS71284SCW	9.760"	81.280"	0.245"
	90"W TS71290SCW	9.760"	87.280"	0.245"
96"W TS71296SCW	9.760"	93.280"	0.245"	
18"H	24"W TS71824SCW	15.940"	21.280"	0.245"
	30"W TS71830SCW	15.940"	27.280"	0.245"
	36"W TS71836SCW	15.940"	33.280"	0.245"
	42"W TS71842SCW	15.940"	39.280"	0.245"
	48"W TS71848SCW	15.940"	45.280"	0.245"
	60"W TS71860SCW	15.940"	57.280"	0.245"
	72"W TS71872SCW	15.940"	69.280"	0.245"
	78"W TS71878SCW	15.940"	75.280"	0.245"
	84"W TS71884SCW	15.940"	81.280"	0.245"
	90"W TS71890SCW	15.940"	87.280"	0.245"
96"W TS71896SCW	15.940"	93.280"	0.245"	
24"H	24"W TS72424SCW	22.120"	21.280"	0.245"
	30"W TS72430SCW	22.120"	27.280"	0.245"
	36"W TS72436SCW	22.120"	33.280"	0.245"
	42"W TS72442SCW	22.120"	39.280"	0.245"
	48"W TS72448SCW	22.120"	45.280"	0.245"
	60"W TS72460SCW	22.120"	57.280"	0.245"
	72"W TS72472SCW	22.120"	69.280"	0.245"
	78"W TS72478SCW	22.120"	75.280"	0.245"
	84"W TS72484SCW	22.120"	81.280"	0.245"
	90"W TS72490SCW	22.120"	87.280"	0.245"
96"W TS72496SCW	22.120"	93.280"	0.245"	

Sliding Panel Doors

Sliding door is handed and can be added to workstations for additional privacy.
 ▶ Specifying, page 478

Door must be installed on the outside of the workstation.

Door is attached to the host panel only; therefore, the stability of the door is closely related to the stability of the host panel.

Sliding door can be specified with lock option. Specify lock cylinder and key separately.

Receiving panel – height of receiving panel must match height of the door.

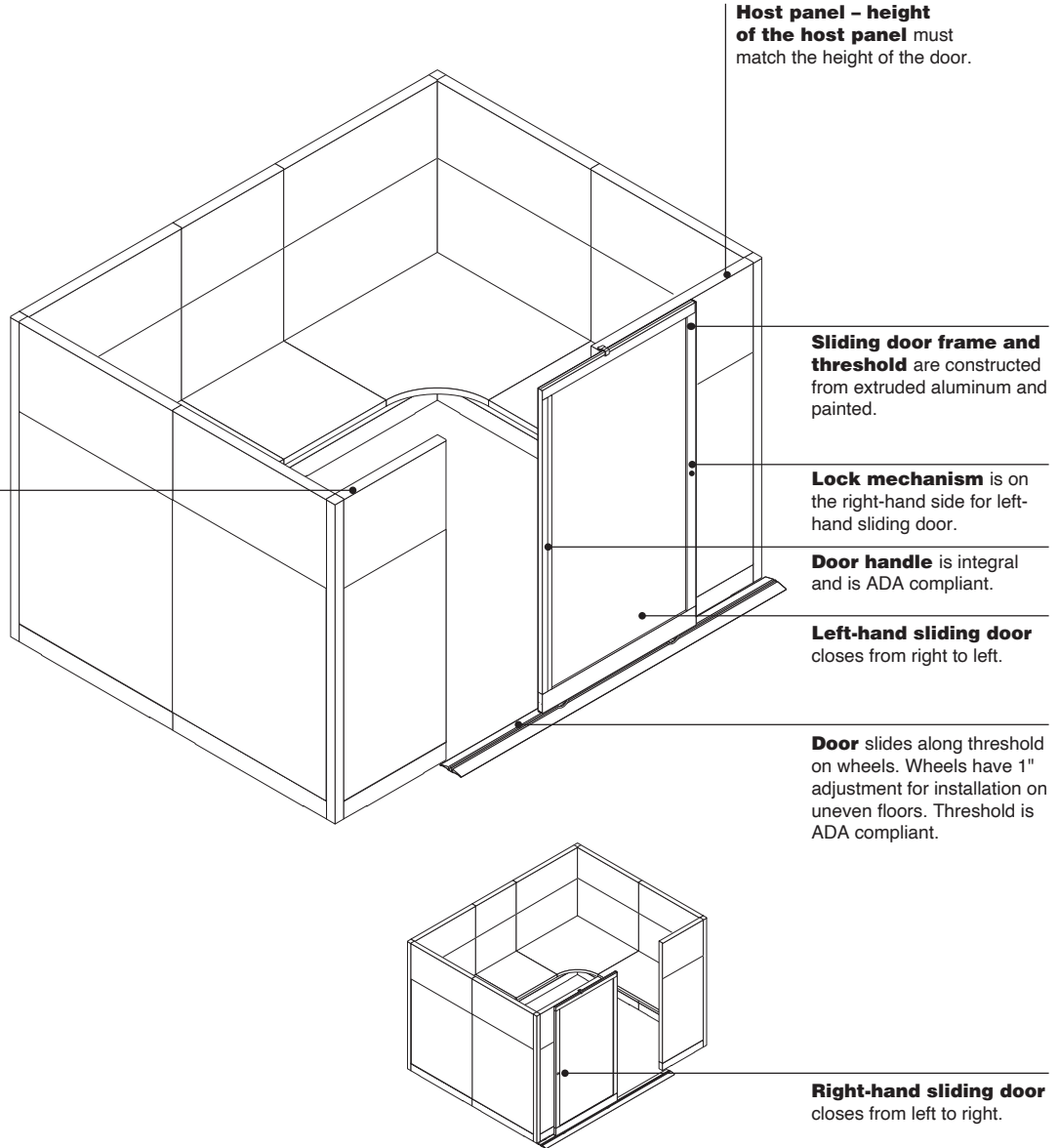

Host panel – height of the host panel must match the height of the door.

Sliding door frame and threshold are constructed from extruded aluminum and painted.

Lock mechanism is on the right-hand side for left-hand sliding door.

Door handle is integral and is ADA compliant.

Left-hand sliding door closes from right to left.

Door slides along threshold on wheels. Wheels have 1" adjustment for installation on uneven floors. Threshold is ADA compliant.

Right-hand sliding door closes from left to right.

Lock mechanism is on the left-hand side for right-hand sliding door.

Actual Dimensions

Door Height 66" and 78"

Door Width 36" and 42"

Door Thickness 1 1/4"

Product Details

Sliding door is handed. Right-handed sliding door or left-handed sliding door must be specified.

Sliding door can be specified with lock option. Specify lock cylinder and key separately.

Door infill is standard in ribbed, translucent plastic. Clear tempered glass and white laminated glass are available as options.

Surface Materials

Frame and door track

- Paint

Door infill

- 6625 Translucent Plastic
- 6500 Clear glass
- 6541 White laminated

Application Topics

Sliding door is not free-standing. It must mount to panels.

Door is attached to the host panel only. Therefore, the stability of the door is closely related to the stability of the host panel.

▶ See Guidelines for Sliding Door Applied to Answer, page 156.

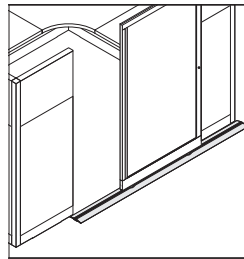

Door track is attached to both host panel and opposite panel.

Height of door must match height of host panel – 66"H or 78"H.

Match the width of the host panel to the width of the door, if possible.

When attaching the sliding door to an Answer panel, a junction stabilizer bracket is available for added rigidity to the host panel. If a host and/or receiving panel run exceeds 4', a junction stabilizer bracket must be applied to the door end of the host and/or receiving panel run. On long runs, apply a junction stabilizer bracket or perpendicular panel every 8'.

Sliding panel door cannot attach to a stacking junction. Host panel must be a single base junction.

The doorway side of the host panel must be an end-of-run junction. The doorway end of the host panel cannot be an L junction.

Panel and Beam Foot

The panel and beam foot supports up to a 48"H panel run freestanding without additional support from fin panels, tethered worksurfaces, or support legs.
 ▶ Specifying, page 480

A panel and beam foot can also be used to make a panel run taller than 48"H feel more stable, but is not an alternative to a perpendicular panel or other panel support for stability purposes.
 ▶ See Stability Guidelines page 140, for more information.

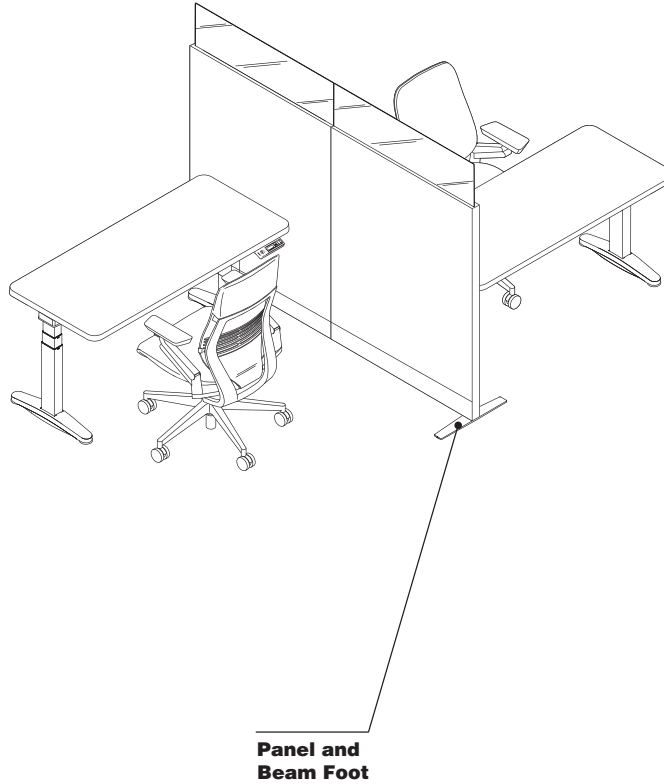

Product Details

Panel and beam foot attaches to end-of-run and in-line junctions to support a freestanding panel run.

Vertical attachment post is offset on the panel and beam foot and allows for a choice of proud or inset installation at the end-of-run by rotating the panel and beam foot.

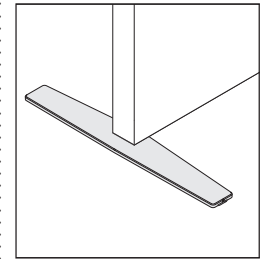

Panel and beam foot positioned proud of the end of run accommodates Ology, Migration, and Airtouch height adjustable desks. It is used parallel to the panel without overlapping table supports and panel feet.

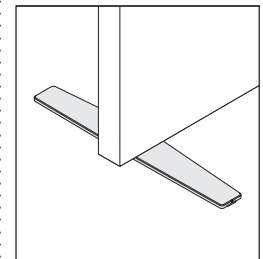

Panel and beam foot positioned inset from the end-of-run provides a cleaner visual and accommodates Ology, Migration, and Airtouch desks.

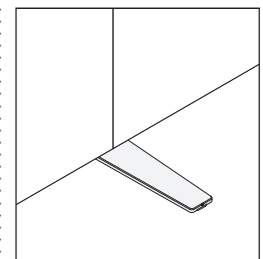

Panel and beam foot will be centered on in-line junctions.

Actual Dimensions

Width	31/4"
Length	21"
Height	5/8"

Panel and beam foot only attaches to junctions manufactured on or after October 10, 2011.

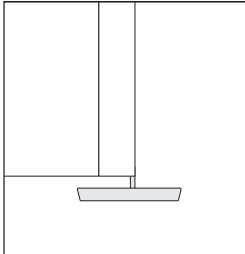

Glide for use with panel and beam foot is included in the hardware package and installs in the field to maintain standard panel height and minimize the gap between the panel and floor.

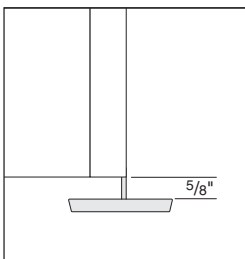

Standard glides can be used in conjunction with the panel and beam foot but will result in a $\frac{5}{8}$ " larger gap between the bottom of the panel and the floor.

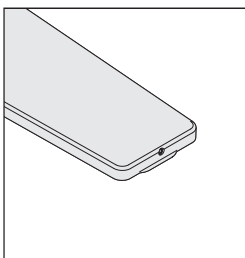

Set screws in the end of the foot provide $\frac{1}{4}$ " of micro adjustment.

Surface Materials

Foot
• Paint

Application Topics

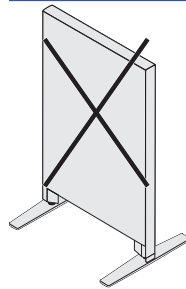

Open base trim cannot be used in conjunction with a panel and beam foot.

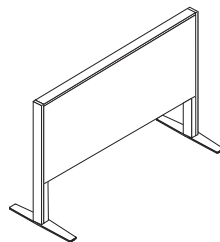

Big open base trim can be used in conjunction with a panel and beam foot.

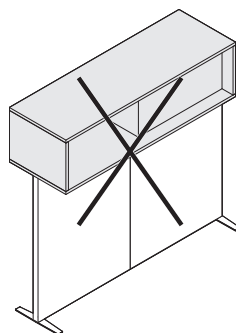

Top cap mounted storage is not permitted on freestanding panel runs supported by panel feet.

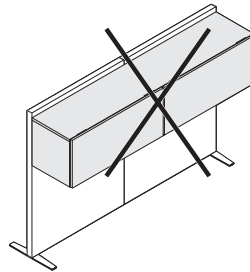

Panel hung storage is not permitted on freestanding panel runs supported by feet.

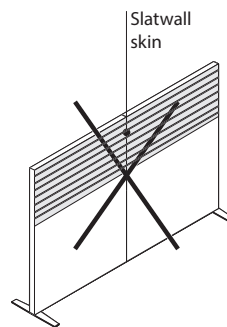

Slatwall skins are not allowed on freestanding panel runs supported by panel feet.

Wiring & Cabling

Panel and beam foot blocks power routing in the panel base and just above the base areas. The vertical attachment post covers the slots on the junction where the powerkit connects in these two zones. It also blocks the ability for a powerkit harness, pass-through powerkit, or modular harness to route in the base area from an adjacent panel.

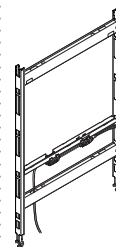

Multipurpose infeed connects power from the building floor into a panel run supported by panel feet. Conduit can be run under the panel or through a knockout in the basetrim, and must be attached to the bottom horizontal beam with 24206001SR strain relief bracket from service parts.

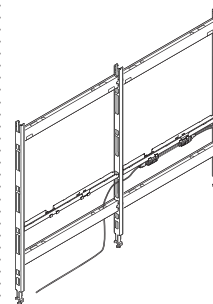

San Francisco power infeed can be used if liquid tight conduit is required. Plan to have a long enough infeed to attach to a modular power kit in the panel adjacent to the entry panel.

Power can be accessed in the third position up from the base through field cut fabric skins or technology skins.

Stability Guidelines

Answer, when installed properly, is an exceptionally stable furniture system. That applies to workstations using panels alone, panel-supported components, or freestanding furniture.

Counterweight packages for storage products are required to ensure product stability.

▶ See page 265 for *Counterweight Requirements for Storage Products*.

The following section on panel stability gives some guidelines to be used with common system furniture configurations. Guidelines are given to panels with and without components. Consult your local dealer or Steelcase representative prior to deviating from these guidelines.

When panel height exceeds six feet in seismic geographical areas rated at a 3 or 4, floor plans must be submitted to a certified structural engineering firm to assure the product application complies with applicable building codes. Steelcase is not responsible for consultation fees. Maximum allowable stacked panel height is 90".

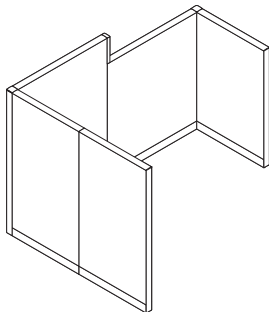

Change-of-height has no effect on these stability guidelines unless otherwise specified.

There are several ways to anchor the end of a panel run:

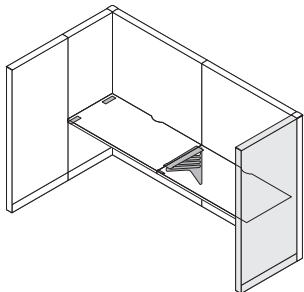

With a return panel.

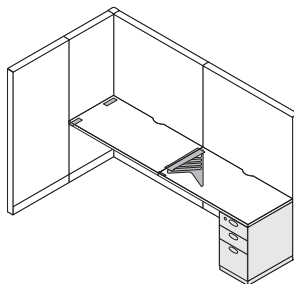

With a pedestal, pedestal filler, or a lateral file with a storage-to-panel connector.

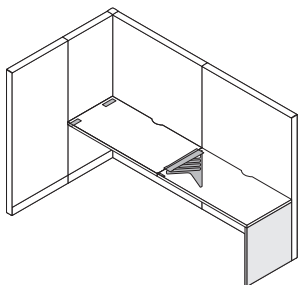

With an end panel.

Guidelines for Panel-Hung Components
▶ Page 141

Guidelines for "L" Configurations
▶ Page 142

Guidelines for "T" Configurations
▶ Page 143

Guidelines for Support Brackets: No Overheads or Panel-Hung Components
▶ Page 145

Guidelines for Support Brackets: Overheads or Panel-Hung Components
▶ Page 145

Guidelines for Support Brackets
▶ Page 146

Guidelines for "U" Configurations
▶ Page 146

Guidelines for "X" Configurations
▶ Page 147

Guidelines for "V" Configurations
▶ Page 148

Guidelines for "Y" Configurations
▶ Page 149

Guidelines for Bench Configurations without Top Cap Mounted Storage
▶ Page 150

Guidelines for Bench Configurations with Top Cap Mounted Storage
▶ Page 151

Guidelines for Wall-Start Junction Configurations
▶ Page 154

Guidelines for Answer Off-Module Bracket Configurations
▶ Page 155

Guidelines for Sliding Panel Door Applied to Answer
▶ Page 156

Guidelines for Freestanding Panels Supported by Panel and Beam Foot
▶ Page 155

Guidelines for Answer Panel-Hung Components

These guidelines treat shelves and bins as interchangeable.

- If bins or shelves are applied at an elevation higher than 66", a perpendicular panel of same height (or up to 24" lesser height) is required.
- Top of universal sliding door bin is not designed to support the weight of a seated person.
- When ganging bins or shelves, the use of a tie plate is required.
- When stacking bins, at least 2 inches of clearance from the bottom is required to access the lock.

In all cases, up to two panel-hung components may be used per panel, per side. These are some common applications:

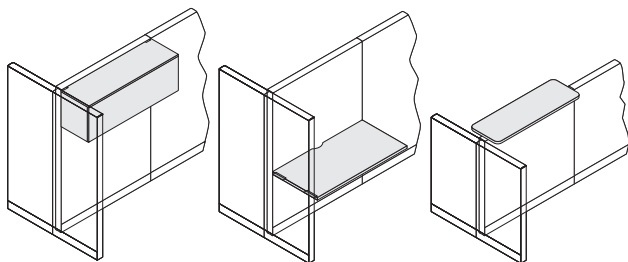

Hanging one component on one side.

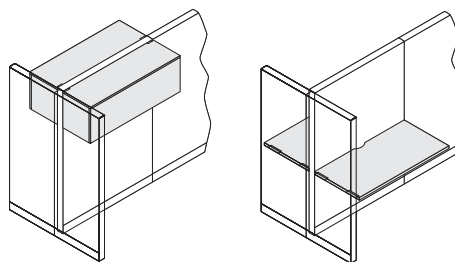

Hanging one component on each side.

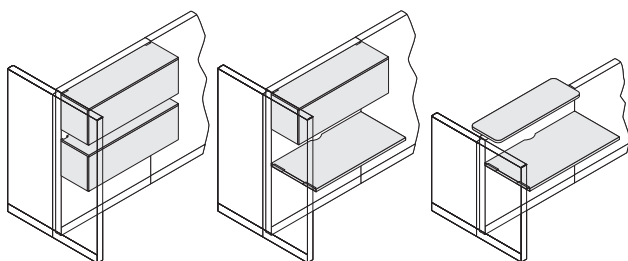

Hanging two components on one side.

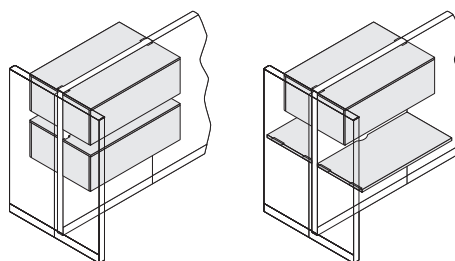

Hanging two components on each side.

When 24"W return panels are placed adjacent to each end of components, you may use up to four shelves or bins on a panel (without worksurfaces).

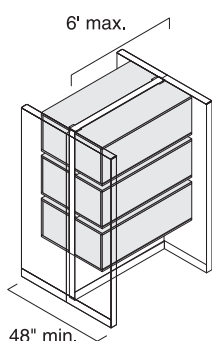

Three shelves or bins, 48" maximum vertical loading space including top.

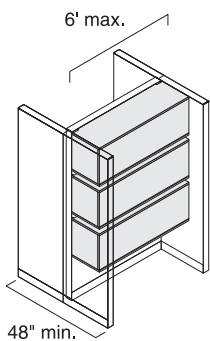

Three shelves or bins, 48" maximum vertical loading space including top.

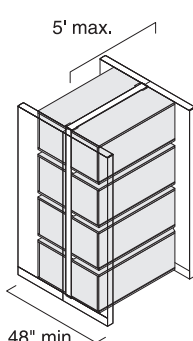

Four shelves or bins, 60" maximum vertical loading space including top.

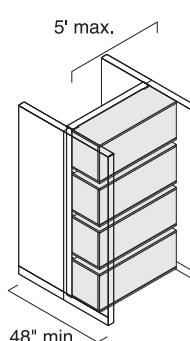

Four shelves or bins, 60" maximum vertical loading space including top.

Guidelines for "L" Configurations

Panels with Panel-Hung Components

If **A** is up to 12' or less, you need to have either a pedestal with filler, a jetty or bubble jetty worksurface, or an end panel on end. Maximum 8' of shelves or bins per panel run.

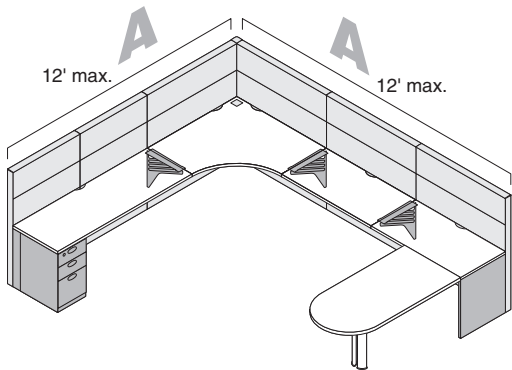
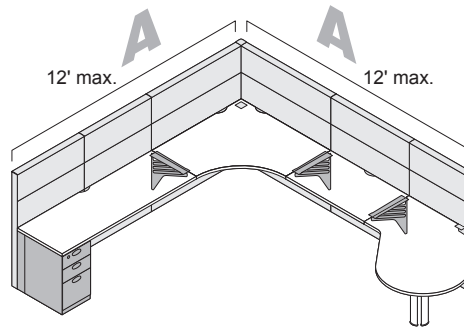
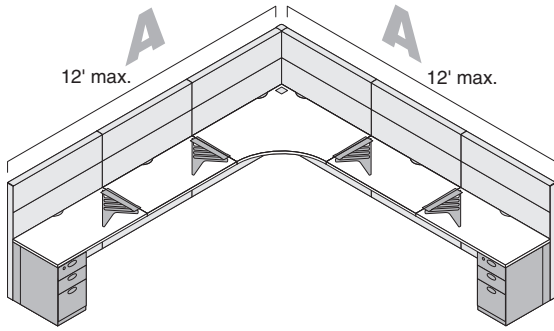

Guidelines for "T" Configurations

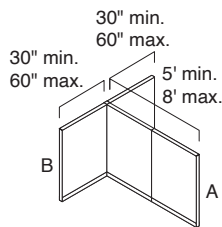

An 8' run with no panel-hung component does not require a return panel. For additional stability or longer runs, apply a junction stabilizer bracket every 8' bolted to a concrete floor.

In change-of-height configuration when panel A height is shorter than panel B height, a junction stabilizer bracket must be applied to the panel A.

When back painted glass is located on the return panels, the return panel height must be equal to or shorter than the spine panel height.

Note: The minimum spine length is 6'.

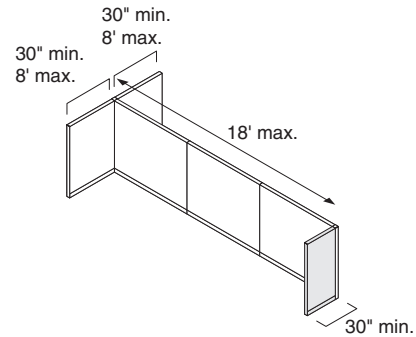

For runs over 8' up to 18', you must use at least a 30"W return panel.

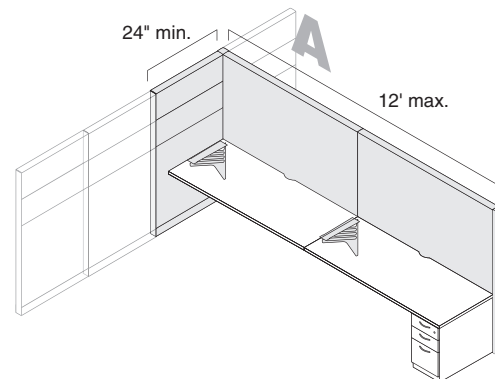

When back painted glass skins are used on the spine panels, a rear facing return panel is required.

Guidelines for "T" Configurations, continued

Panels without Panel-Hung Components

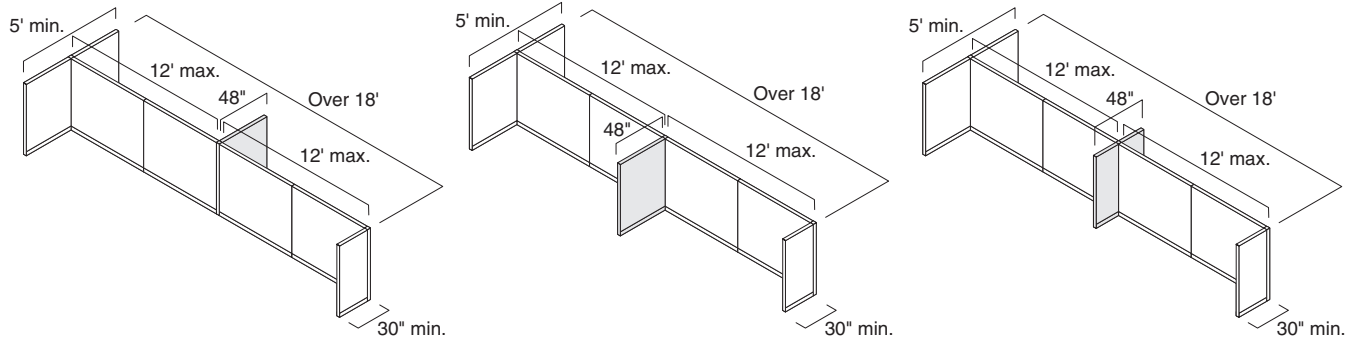

For runs over 18', you must locate a 48"W perpendicular panel every 12'.

Panels with Panel-Hung Components Counterbalanced on Both Sides

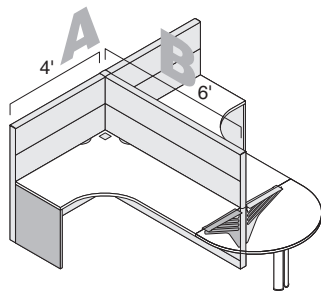

If A is 4' long and B is 6' long, you must use an end panel and a cantilever.

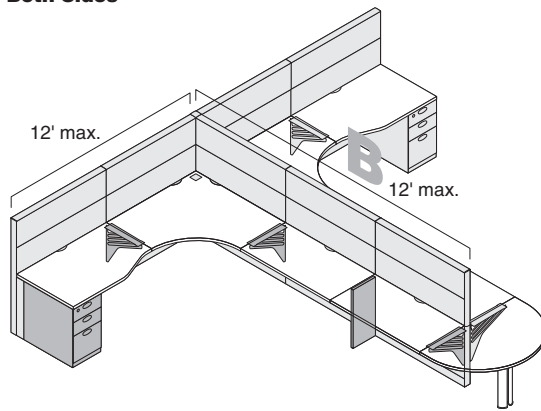

If B is 6' to 12', you must use one center support panel per side. Maximum 8' of shelves or bins per panel run.

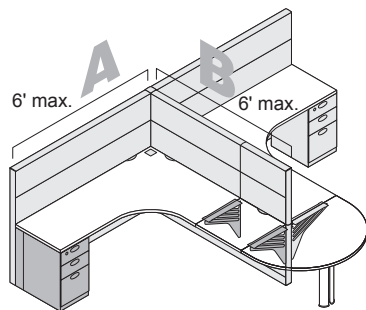

If B is up to 6' long, you can use cantilevers to support adjoining worksurfaces.

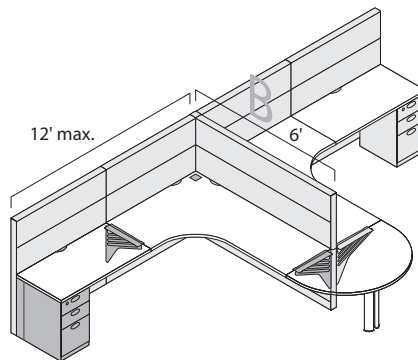

If B is up to 6' long, you can use cantilevers to support adjoining worksurfaces. Maximum 8' of shelves or bins per panel run.

Guidelines for Support Brackets: No Overheads or Panel-Hung Components

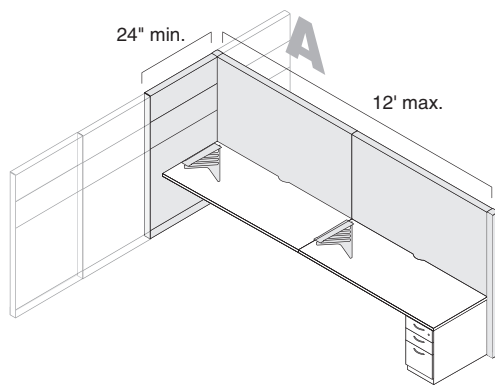
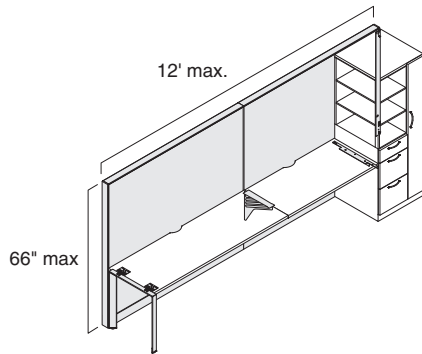

One end of panel run must be supported by:

- Panel that is minimum 24" wide.
- Tower with tall storage-to-panel connector (24"D or 30"D)

Other end of panel run can be supported by:

- Open loop leg
- Closed loop leg
- Pedestal with filler
- End panel
- 1.5H or 2H storage with storage-to-panel connector
 - 18"D or 24"D cabinet in perpendicular application
 - 24"D cabinet in parallel application
- Tower with medium storage-to-panel connector

Worksurfaces 26" D or less:

- Can be completely supported by cantilever brackets or a combination of cantilever and side support brackets, pedestals, legs (post, open loop, closed loop), end panel support, and 1.5H storage with intermediate support.
- When using cantilevers to support a 26"D or less worksurface, minimum return panel width is 30". Panel width can be reduced to 24"D to match the worksurface depth of a 24"D worksurface if side support brackets are applied.

Worksurfaces greater than 26" D:

- Straight and transition worksurfaces require additional floor support along the front edge at each end, such as side support brackets, pedestal, or post leg.

Guidelines for Support Brackets: Overheads or Panel-Hung Components

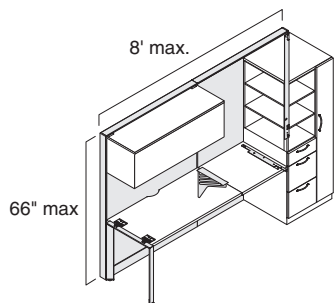

Tip: Overhead bin or shelf cannot span over or be positioned over tower.

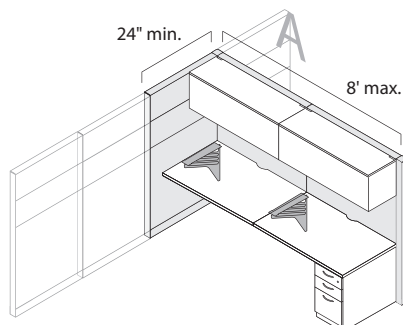

One end of panel run must be supported by:

- Panel that is minimum 24" wide.
- Tower with tall storage-to-panel connector (24"D or 30"D)

Other end of panel run can be supported by:

- Open loop leg
- Closed loop leg
- Pedestal with filler
- End panel
- 1.5H or 2H storage with storage-to-panel connector
 - 18"D or 24"D cabinet in perpendicular application
 - 24"D deep cabinet in parallel application
- Tower with medium storage-to-panel connector

Worksurfaces 26" D or less:

- Can be completely supported by cantilever brackets or a combination of cantilever and side support brackets, pedestals, legs (post, open loop, closed loop), end panel support, and 1.5H storage with intermediate support.
- When using cantilevers to support a 24"D worksurface, minimum return panel width is 30". Panel width can be reduced to 24"D to match the worksurface depth if side support brackets are applied.

Worksurfaces greater than 26" D:

- Straight and transition worksurfaces require additional floor support along the front edge at each end, such as side support brackets, pedestal, or post leg.

Guidelines for Support Brackets

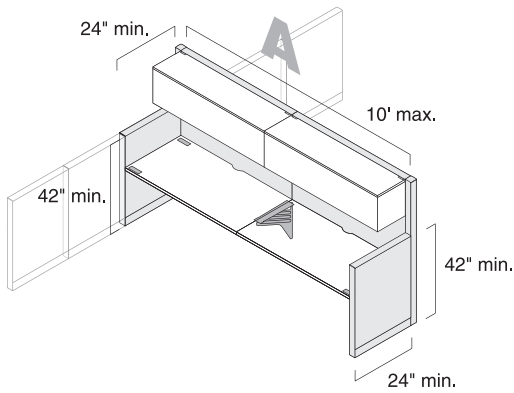

If A is between 8' and 10', side support brackets are required at each end of the run. Both ends of loaded panel run must be supported by perpendicular panels.
Note: Panel fin on one side can be replaced by a tower with a tall storage-to-panel connector as long as the tower is not outside the panel run and the overhead bin or shelf is not spanning over or positioned over the tower.

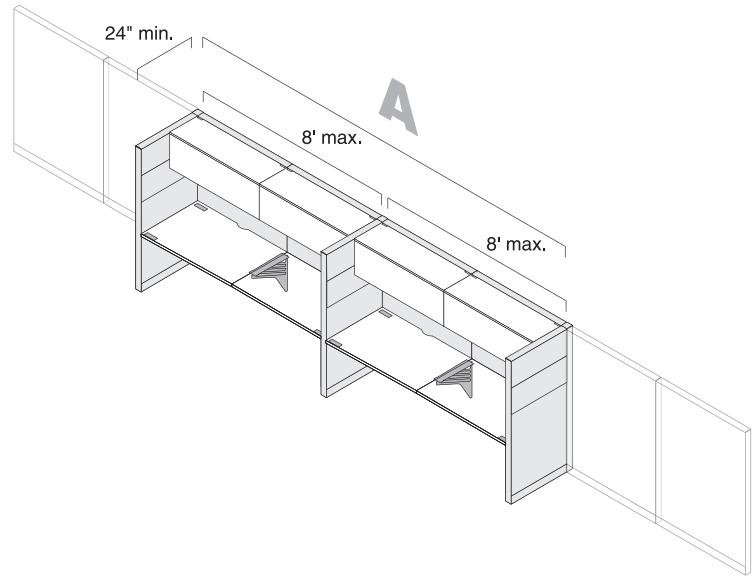

If A is greater than 10', side support brackets are required at both ends of each worksurface. Full height perpendicular panels need to support the loaded panels every 8'.

Guidelines for "U" Configurations

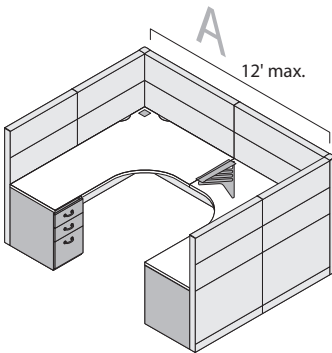

If A is 12' or less, no floor support is required mid-run. Maximum 8' of shelves or bins per panel run.

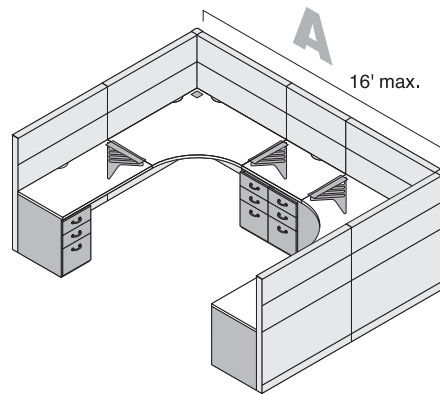

If A is between 12' and 16', some type of floor support is required mid-run. Maximum 8' of shelves or bins per panel run.

Guidelines for "X" Configurations

Panels without Components

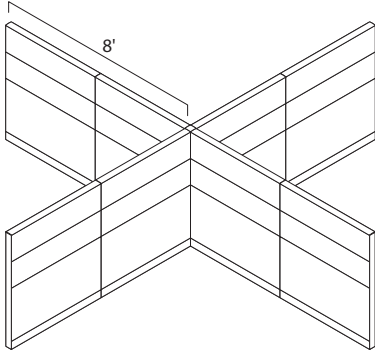

For additional stability or longer runs, apply a junction stabilizer bracket every 8' bolted to a concrete floor.

Panels with Components

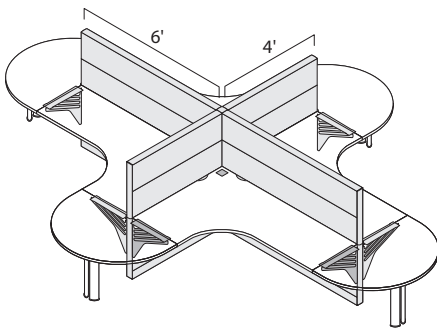

If panel is 6' or less, no center support is needed.

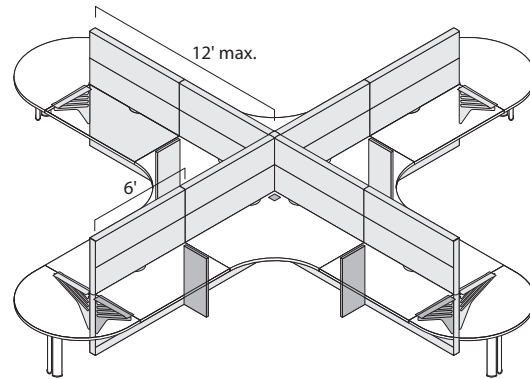

Center support panel is needed every 6'. Cantilevers can be used to tie spanner in. Maximum 8' of shelves or bins per panel run.

Guidelines for "V" Configurations

Panels with Components

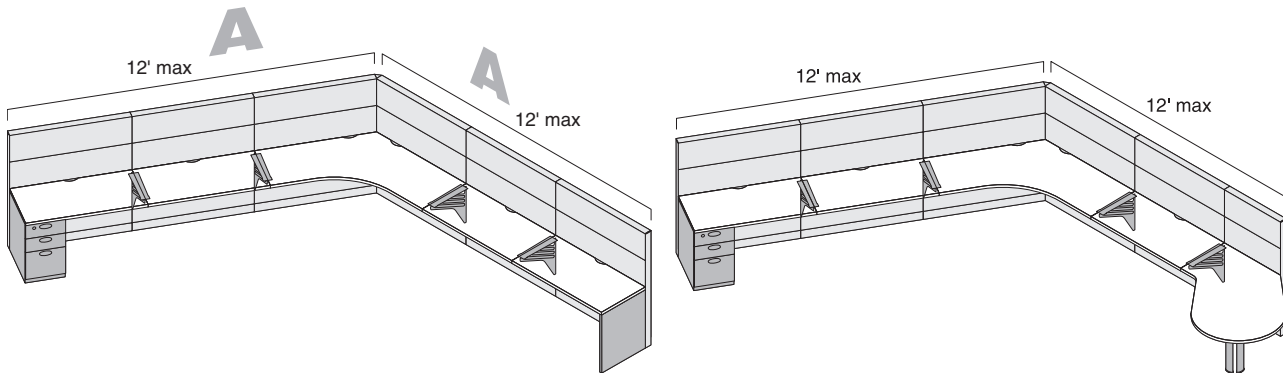

If A is up to 12' or less, you need to have either a pedestal with filler, a jetty or bubble jetty worksurface, or an end panel on end. 26"D or greater straight worksurfaces and 30"D transition worksurfaces require additional floor support along the front edge, such as a pedestal or post leg. Maximum 8' of shelves or bins per panel run.

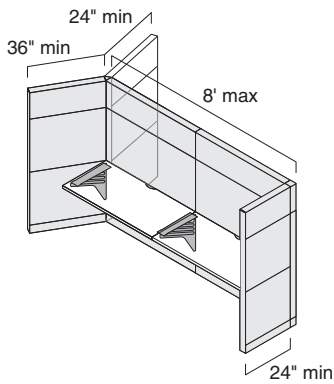

"U" configuration must have a cantilever with the 120° V junction. The other end needs to be supported with a full-height panel, end panel, or a pedestal with filler.

No components can be hung on back side of panel run unless in a "Y" configuration.

When back painted glass skins are used on the spine panels a rear facing return panel is required.

Guidelines for "Y" Configurations

Panels without Components

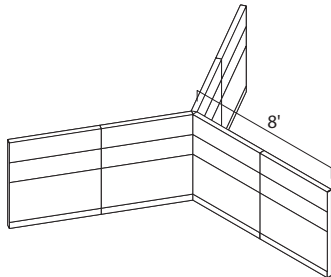

For additional stability or longer runs, apply a junction stabilizer bracket every 8' bolted to a concrete floor.

Panels with Components

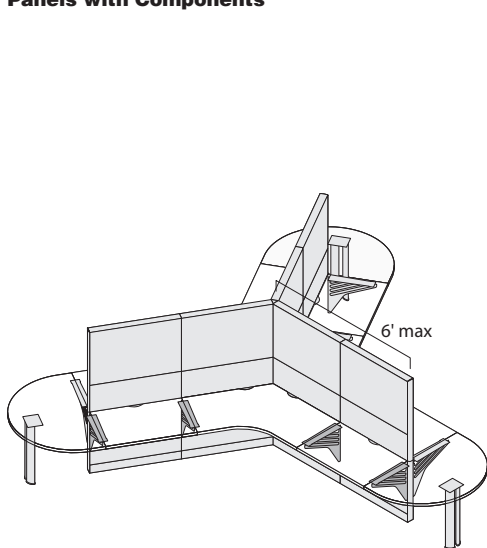

If panel is 6' or less, no center support is needed.

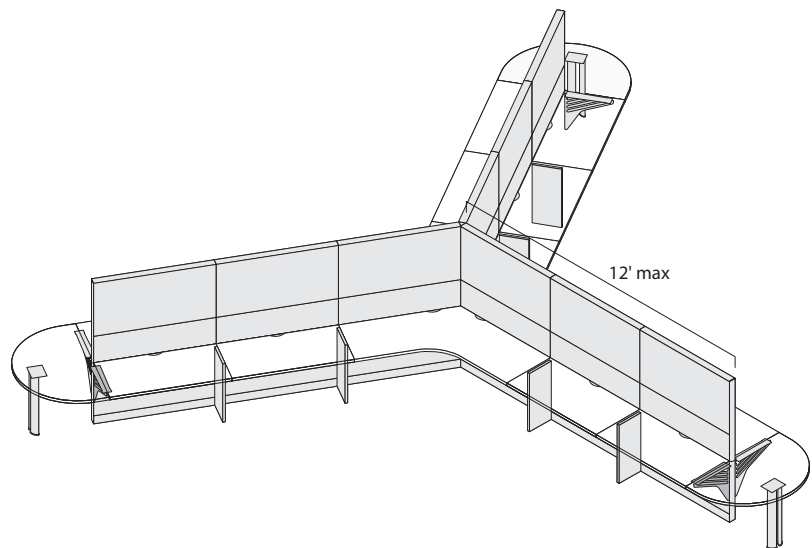

Center support panel is needed every 6'. Cantilevers can be used to tie spanner in. Maximum 8' of shelves or bins per panel run.

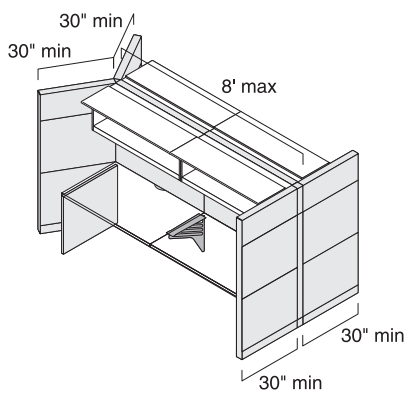

"Y" configuration must have an end panel with a connector bracket with the 120° Y junction. The other end needs to be supported with a full-height panel, end panel, or a pedestal with filler. For worksurfaces 26"D or less, the center can be supported by a cantilever when bins and worksurfaces are used on both sides (as shown). 26"D or greater straight worksurfaces and 30"D transition worksurfaces require additional floor support along the front edge, such as a pedestal or post leg.

Note: When using cantilevers to support a worksurface 26"D or less, minimum panel width is 30". Panel width can be reduced to 24" to match a 24"D worksurface if side support brackets are applied.

Guidelines for Bench Configurations without Top Cap Mounted Storage

Single Sided Bench

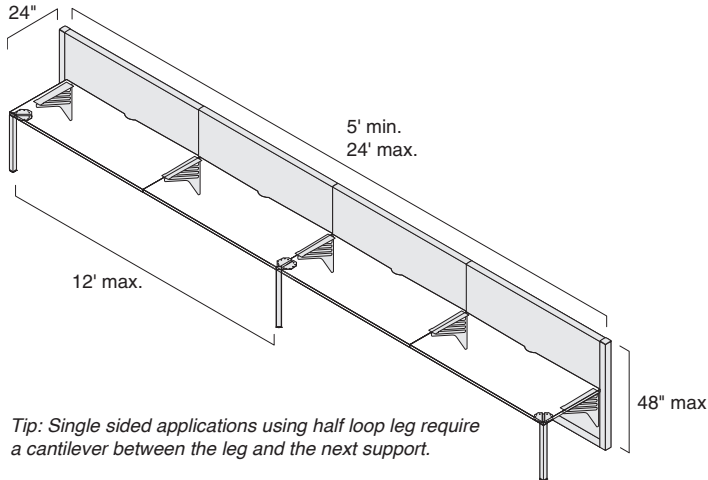

Tip: Single sided applications using half loop leg require a cantilever between the leg and the next support.

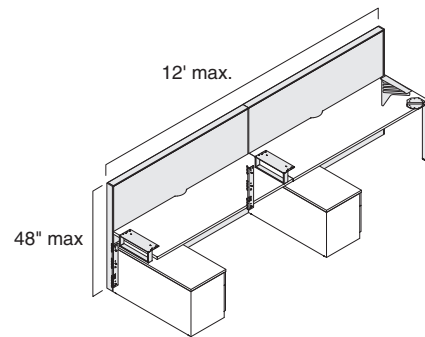

Double Sided Bench

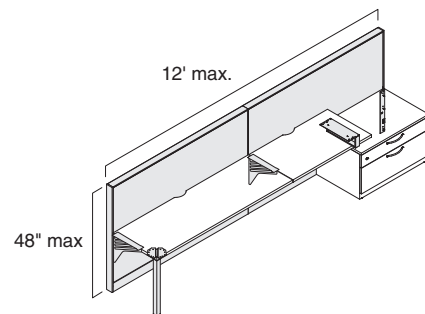
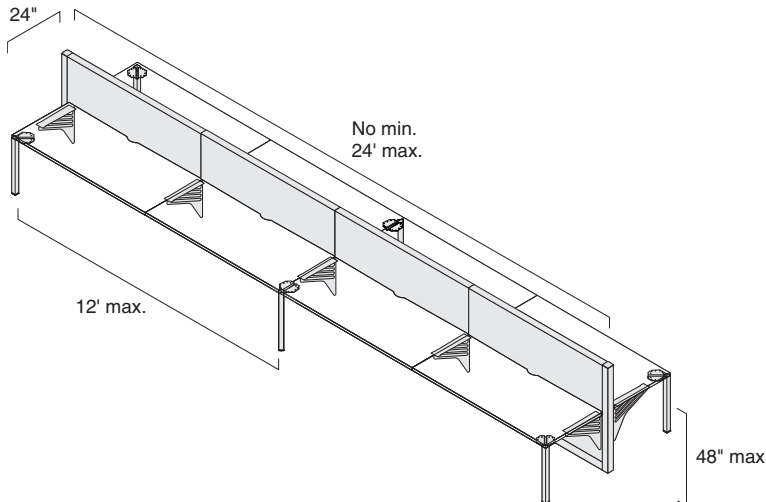

End-of-run support options include:

- Post leg and cantilever
- Half loop leg
- Open loop leg
- Closed loop leg
- Worksurface end panel
- Pedestal with filler
- 1H, 1.5H, or 2H (18" on 24"D) cabinet with panel-to-storage connector in perpendicular application.
Note: 1H and 1.5H cabinet requires intermediate support.
- 1H, 1.5H, or 2H (24"D) cabinet with panel-to-storage connector in parallel application.
Note: 1H and 1.5H cabinet requires intermediate support.
- Tower with medium storage-to-panel connector

Maximum worksurface depth is 26" with front support every 12'.

Worksurfaces greater than 26"D require legs in the front of each worksurface on both ends of the worksurface.

Center support panels cannot be used as supports.

Slim shelves and slatwall skins (including monitor arm attachment) can be applied, but bins and universal shelves are not allowed.

Guidelines for Bench Configurations with Top Cap Mounted Storage, continued

Single Sided Bench with Aisleway Top Cap Mounted Storage

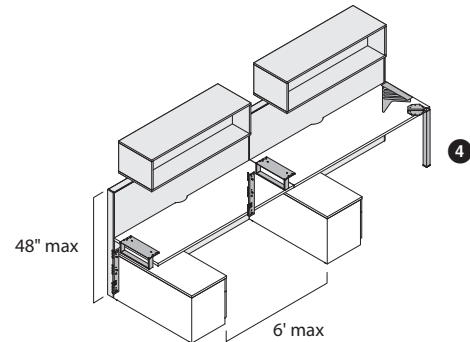
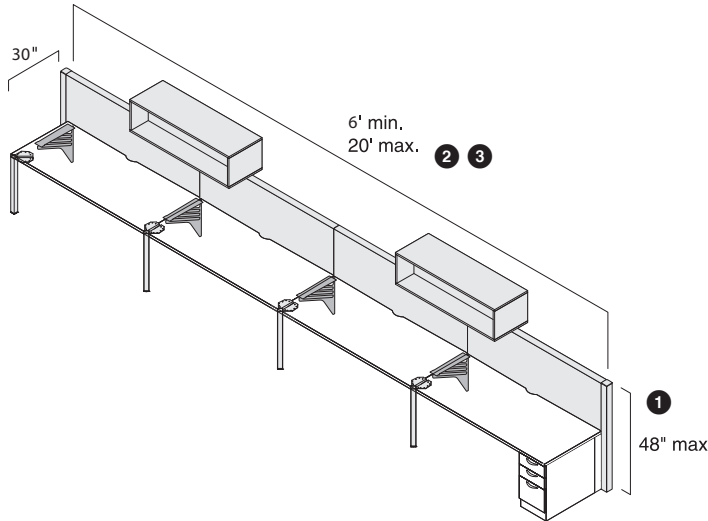

For single sided bench with aisleway top cap mounted storage, worksurface support must include at least one of the following:

- Pedestal with filler
- 1H, 1.5H, or 2H (18" on 24"D) cabinet with panel-to-storage connector in perpendicular application.
Note: 1H and 1.5H cabinet requires intermediate support.
- 1H, 1.5H, or 2H (24"D) cabinet with panel-to-storage connector in parallel application.
Note: 1H and 1.5H cabinet requires intermediate support.
- Tower with medium storage-to-panel connector

End-of-run support options include:

- Post leg and cantilever
- Half loop leg
- Open loop leg
- Closed loop leg
- Worksurface end panel
- Pedestal with filler
- 1H, 1.5H, or 2H (18" on 24"D) cabinet with panel-to-storage connector in perpendicular application.
Note: 1H and 1.5H cabinet requires intermediate support.
- 1H, 1.5H, or 2H (24"D) cabinet with panel-to-storage connector in parallel application.
Note: 1H and 1.5H cabinet requires intermediate support.
- Tower with medium storage-to-panel connector

For single sided bench applications with aisleway top cap mounted storage, worksurface depth must be 30"D.

30"D worksurfaces require legs in the front of each worksurface on both ends of the worksurface.

Center support panels cannot be used as supports.

Slim shelves and slatwall skins (including monitor arm attachment) can be applied, but bins and universal shelves are not allowed.

- 1** *Tip: The maximum panel height with Duo, Currency storage, and Elective Elements storage is 48".*
- 2** *Tip: In aisleway applications, the back of the storage overhangs the panel 3.5".*
- 3** *Tip: Aisleway mounting can accept storage up to 17"D.*
- 4** *Tip: When using storage to panel connectors to support the panel application, the maximum distance between storage to panel connection is 6'.*

Guidelines for Bench Configurations with Top Cap Mounted Storage, continued

Double Sided Bench with Center Top Cap Mounted Storage

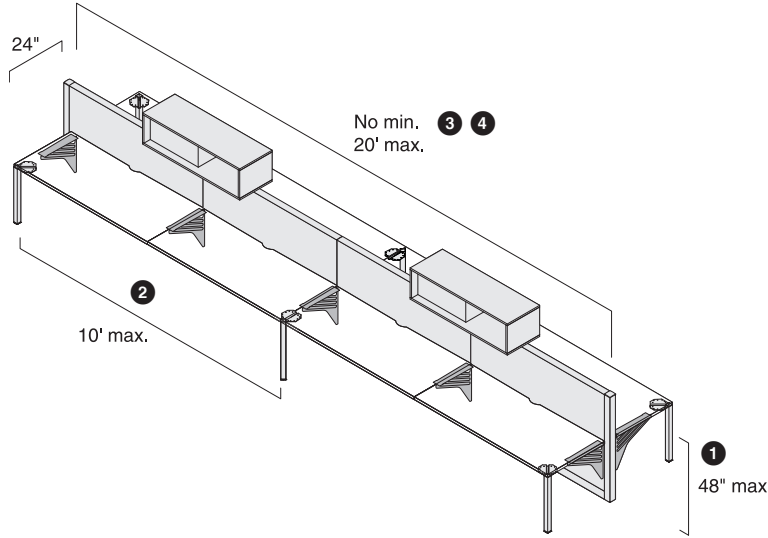

- 1 Tip: The maximum panel height with Duo, Currency, and Elective Elements storage is 48".
- 2 Tip: 10' max between legs when using legs and cantilevers to support panel.
- 3 Tip: When top cap storage is center maintained, the storage is shared equally on top of the panel.
- 4 Tip: Center mounting can accept storage up to 25"D.

End-of-run support options include:

- Post leg and cantilever
- Half loop leg
- Open loop leg
- Closed loop leg
- Worksurface end panel
- Pedestal with filler
- 1H, 1.5H, or 2H (18" on 24"D) cabinet with panel-to-storage connector in perpendicular application.
Note: 1H and 1.5H cabinet requires intermediate support.
- 1H, 1.5H, or 2H (24"D) cabinet with panel-to-storage connector in parallel application.
Note: 1H and 1.5H cabinet requires intermediate support.
- Tower with medium storage-to-panel connector

Maximum worksurface depth is 26" with front support every 10'.

Worksurfaces greater than 26"D require legs in the front of each worksurface on both ends of the worksurface.

Center support panels cannot be used as supports.

Slim shelves and slatwall skins (including monitor arm attachment) can be applied, but bins and universal shelves are not allowed.

Guidelines for Wall-Start Junction Configurations

Panels with Components

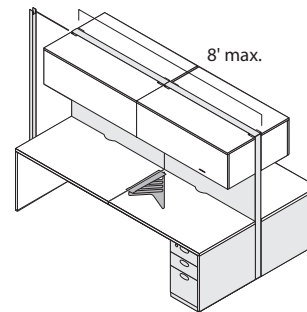
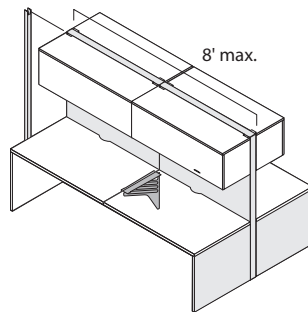
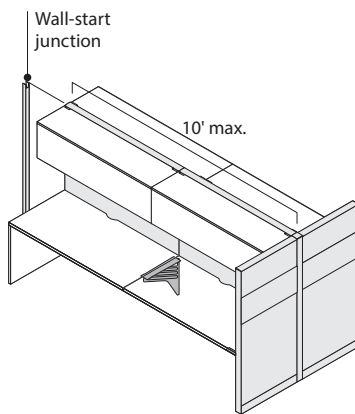
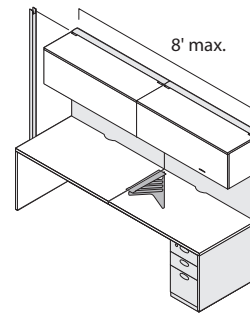
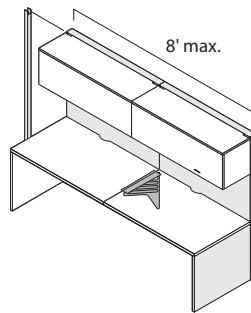
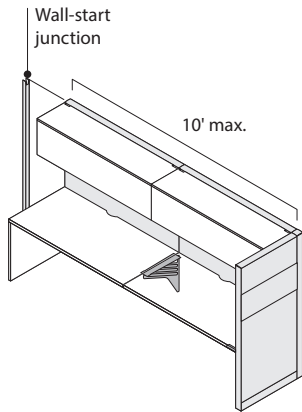

When using a wall-start junction, an end panel must be used with the wall-start junction and the other end must be supported by a full panel, an end panel, or a pedestal with a filler. For worksurfaces 26"D or less, the center can be supported by a cantilever. 26"D or greater straight worksurfaces and 30"D transition worksurfaces require additional floor support along the front edge, such as a pedestal or post leg.

Wall hang channels for shelves and overhead storage bins cannot be used with a wall-start junction.

Tip: Wall-start junctions must secure to the stud in a building wall or use drywall fasteners.

Guidelines for Answer Off-Module Bracket Configurations

Panels with Components

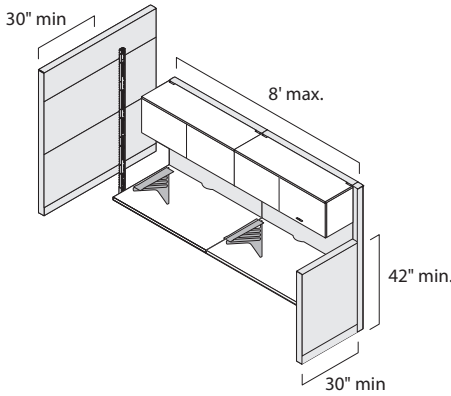

"U" configuration

When using an Answer off-modular connector bracket, a cantilever must be used with the connector bracket. The other end needs to be supported with a panel, end panel, or a pedestal with filler. For worksurfaces 26"D or less, the center can be supported by a cantilever. 26"D or greater straight worksurfaces and 30"D transition worksurfaces require additional floor support along the front edge, such as a pedestal or post leg.

Note: When using cantilevers to support a worksurface 26"D or less, minimum panel width is 30". Panel width can be reduced to 24" to match a 24"D worksurface if side support brackets are applied.

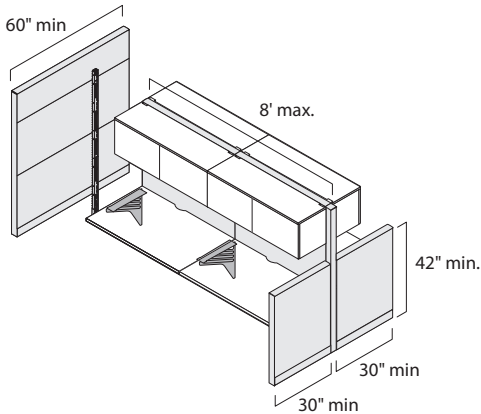

"T" configuration

When using an Answer off-modular connector bracket, a cantilever must be used with the connector bracket. The other end needs to be supported with a panel, end panel, or a pedestal with filler. For worksurfaces 26"D or less, the center can be supported by a cantilever when bins and worksurfaces are used on both sides (as shown). 26"D or greater straight worksurfaces and 30"D transition worksurfaces require additional floor support along the front edge, such as a pedestal or post leg.

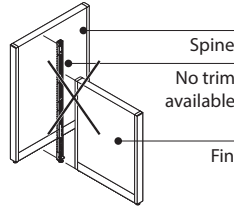

Wall-start junction must match the fin panel height coming off the spine wall. Change-of-height trim is not available to cover exposed wall-start junction.

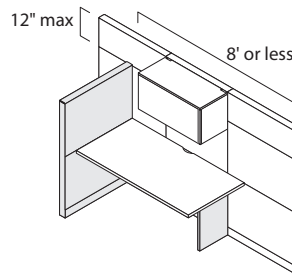

Loading on spine wall with change-of-height off-module fin

is allowed with a maximum of 12" height difference between spine and fin. No loading on spine is permitted if the spine is 24"H or higher than the off-module fin. End panels or a pedestal with a filler is required to support a worksurface attached to spine.

Guidelines for Sliding Panel Door Applied to Answer

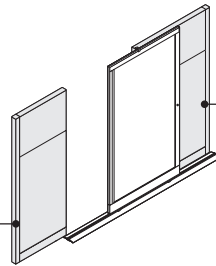

Receiving Panel

- Height of receiving panel must match height of door.
- If receiving panel run exceeds 4', a junction stabilizer bracket must be applied to the door end of the receiving panel run. On long receiving panel runs, apply a junction stabilizer bracket or perpendicular panel every 8'.

Host Panel

- Height of host panel must match height of door.
- Match the width of the host panel to the width of the door.
- If host panel run exceeds 4', a junction stabilizer bracket must be applied to the door end of the host panel run. On long host panel runs, apply a junction stabilizer bracket or perpendicular panel every 8'.

Guidelines for Freestanding Panels Supported by Panel Feet

Single Panel
4' Min

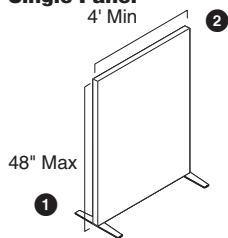

48" Max

- 1 Tip: The maximum panel height is 48"H with up to an additional 12"H frameless glass screen.
- 2 Tip: Single panels supported by panel feet must be at least four feet wide.
- 3 Tip: Freestanding panel runs with multiple panels must have a panel and beam foot every 10 feet.
- 4 Tip: A panel and beam foot is required within three feet of the end of run.

Multiple Panel Run

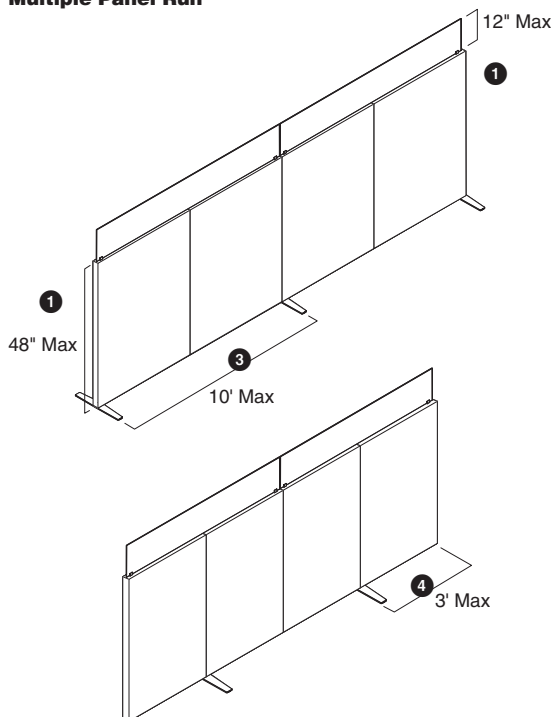

Slim shelves, slatwall skins, and panel-hung or top cap mounted overhead storage bins are not allowed in panel and beam foot supported applications.

Guidelines for media:scape Integration

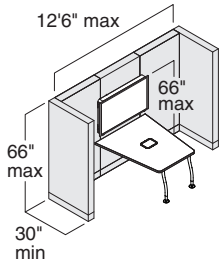

For runs up to 12'6" that have return panels on the same side as the shared workspace, use at least a 30"W return panel that matches the height of the spine wall. For spine walls that exceed 66"H, a 30"W rear facing return panel is required. The monitor mount is not to exceed 66"H.
Tip: Monitor not included with media:scape assembly.

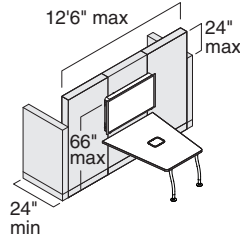

For runs up to 12'6" that have return panels on the opposite side as the shared workspace, use at least a 24"W return panel. The monitor mount is not to exceed 66"H.
Tip: Monitor not included with media:scape assembly.

Understanding Wiring and Cabling

All Answer electrical components are listed by Underwriters Laboratory (UL) and certified by the Canadian Standards Association (CSA).

Statement of Line	158
<hr/>	
Product Details	
Wiring Schematics	161
How to Calculate Power Needs	162
Cable Capacities	164
Interface Products	
Ceiling-Access Lay-In Utility Package	166
Floor-Access Lay-In Utility Package	168
Utility Pole—Thin Trim	170
Junction with Utility Pole	172
Base Power Infeed	174
Special Requirements for New York City	175
Distribution Products	
Powerkits	176
Pass-Through Powerkits	176
Cable Trays	176
Modular Harness	178
Multipurpose Power Infeed	179
Special Requirements for Hardwired Solution	180
Access Products	
Duplex Receptacles	181
USB Receptacles	181
Faceplate	181
Accessories	
Junction Tall Sleeve	183
Lay-In Junction Cable Sleeve	183
Feed-Through Horizontal Cable Sleeve	183
Grommet for Horizontal Bar and Junction	184
Grommet for Junction	184
Duplex Cable Grommet	184

Statement of Line

Interface Products

The **interface** is the point at which the utilities within a panel connect to a building's power and communication network. All power components are field installed.

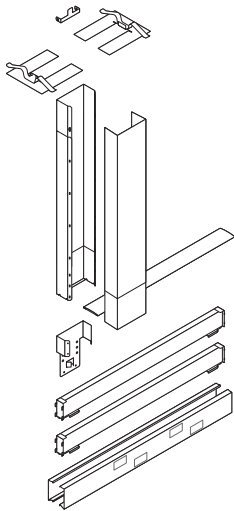

Ceiling-Access Lay-In Utility Package
Understanding
▶ Page 166
Specifying
▶ Pages 348 and 420

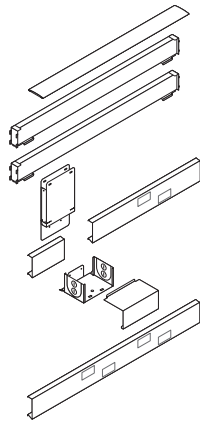

Floor-Access Lay-In Utility Package
Understanding
▶ Page 168
Specifying
▶ Pages 349 and 422



Utility Pole—Thin Trim
Understanding
▶ Page 170
Specifying
▶ Page 347

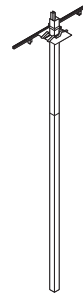

Junction with Utility Pole
Understanding
▶ Page 172
Specifying
▶ Page 418

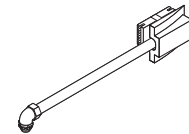

Base Power Infeed
Understanding
▶ Page 174
Specifying
▶ Page 489

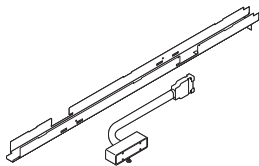

Base Power Infeed for Use in New York City
Understanding
▶ Page 175
Specifying
▶ Page 490

Distribution Products

Distribution refers to the way that power and communication networks are routed through a panel.

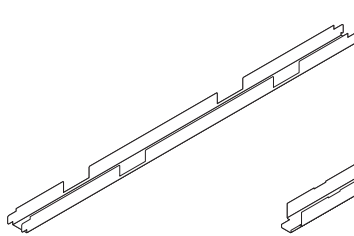

Cable Tray
 Understanding
 ▶ Page 176
 Specifying
 ▶ Page 481

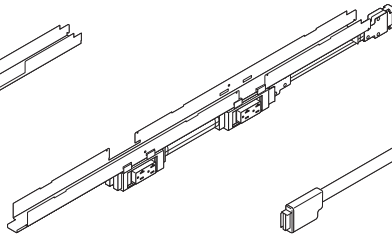

Powerkit
 Understanding
 ▶ Page 176
 Specifying
 ▶ Page 482

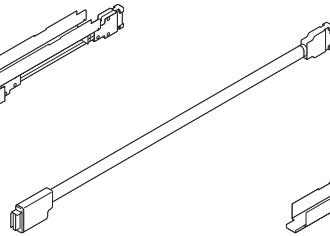

Pass-Through Powerkit
 Understanding
 ▶ Page 176
 Specifying
 ▶ Page 483

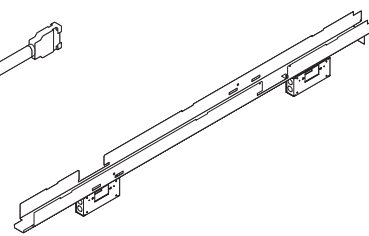

Hardwire Solution for Chicago and Other Areas
 Understanding
 ▶ Page 180
 Specifying
 ▶ Page 491

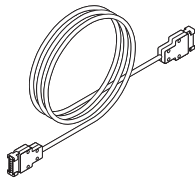

Modular Harness
 Understanding
 ▶ Page 178
 Specifying
 ▶ Page 493

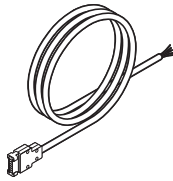

Multipurpose Power Infeed
 Understanding
 ▶ Page 179
 Specifying
 ▶ Page 492

Access Products

Access to power and communication networks is accommodated by power receptacles and communication outlets installed in a panel.



Duplex Receptacles
 Understanding
 ▶ Page 181
 Specifying
 ▶ Page 484



USB Receptacles
 Understanding
 ▶ Page 181
 Specifying
 ▶ Page 485



Faceplate
 Understanding
 ▶ Page 181
 Specifying
 ▶ Page 487



Receptacle Trim Ring
 Understanding
 ▶ Page 182
 Specifying
 ▶ Page 488



Receptacle Filler
 Understanding
 ▶ Page 182
 Specifying
 ▶ Page 488

Access Products, continued

Access to power and communication networks is accommodated by power receptacles and communication outlets installed in a panel.



Data Filler
Understanding
▶ Page 182
Specifying
▶ Page 488

Accessories

Accessories are used to help customize your wiring and cabling needs.



Junction Tall Sleeve
Understanding
▶ Page 183
Specifying
▶ Page 496

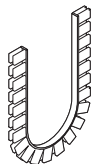

Lay-In Junction Cable Sleeve
Understanding
▶ Page 183
Specifying
▶ Page 497



Feed-Through Horizontal Cable Sleeve
Understanding
▶ Page 183
Specifying
▶ Page 497

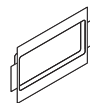

Grommet for Horizontal Bar and Junction
Understanding
▶ Page 184
Specifying
▶ Page 497



Grommet for Junction
Understanding
▶ Page 184
Specifying
▶ Page 498

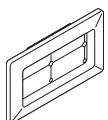

Duplex Cable Grommet
Understanding
▶ Page 184
Specifying
▶ Page 498

Wiring Schematics

Details for the Electrician

Answer offers three different wiring schematics to allow you to match your specific wiring strategy to any typical building wiring plan.

Tip: All the components in an electrical system must use the same wiring schematic. The components are keyed and color coded to make it impossible to connect mismatched parts.

- Black = Four-circuit, 3+1
- Brown = Four-circuit, 2+2
- Rust = Three-circuit, separate neutrals (3SN)
- Shared neutrals = 10 gauge
- Non-shared neutrals = 12 gauge
- Hot wires = 12 gauge

Four-Circuit, 3+1

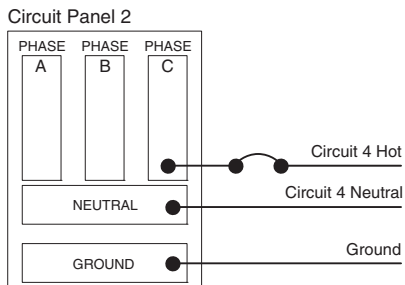
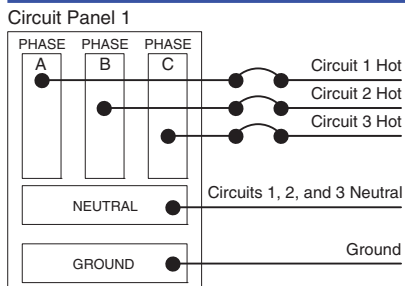

In the four-circuit 3+1 schematic, circuits 1, 2, and 3 are distributed from the first circuit panel and are supported with one shared neutral and one shared ground. Circuit 4 is distributed from a second circuit panel and is supported with a separate neutral and ground.

Single 3-Phase Circuit Panel

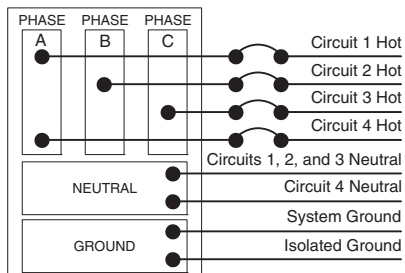

On a single 3-phase circuit panel, all four circuits are distributed as shown.

Four-Circuit, 2+2

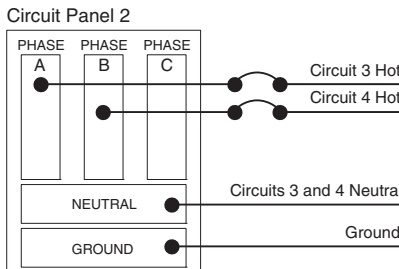
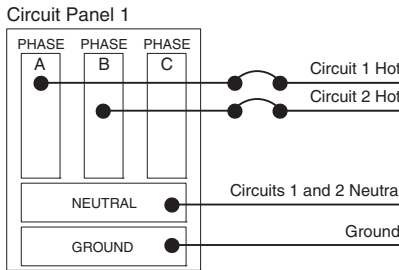

In the four-circuit 2+2 schematic, circuits 1 and 2 are distributed from two different phases from the first circuit panel and are supported with one shared neutral and one shared ground. Circuits 3 and 4 are distributed from a second circuit panel and supported by their own shared neutral and ground.

Single 3-Phase Circuit Panel

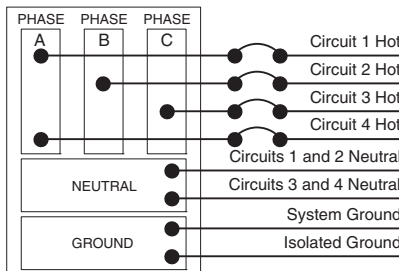

On a single 3-phase circuit panel, all four circuits are distributed as shown.

Split-Phase Circuit Panel

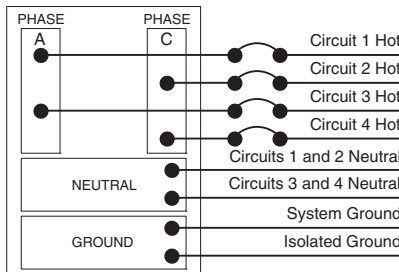

On a split-phase circuit panel, all four circuits are distributed as shown.

Three-Circuit, Separate Neutrals

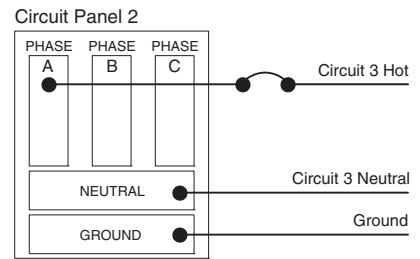
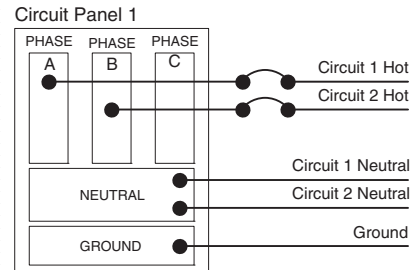

In the three-circuit, separate neutral schematic, circuits 1 and 2 are distributed from two different phases from the first circuit panel. Each circuit is supported with its own neutral and a common ground. Circuit 3 is distributed from the second circuit panel and is supported by its own neutral and ground.

Single 3-Phase Circuit Panel

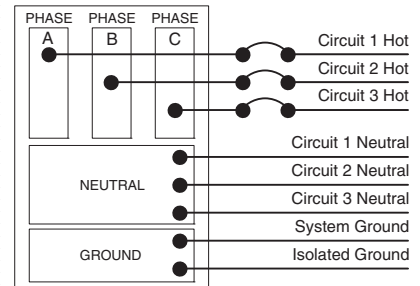

On a single 3-phase circuit panel, three circuits are distributed as shown.

Split-Phase Circuit Panel

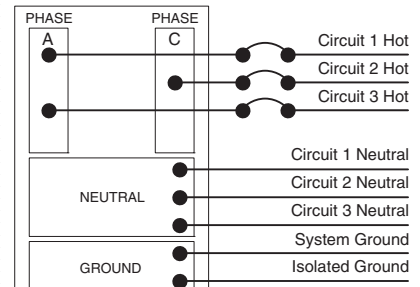

On a split-phase circuit panel, three circuits are distributed as shown.

How to Calculate Power Needs

Use This to Determine How Many Power-Ins You'll Need

When planning a power network, you must calculate the amperage requirements of all your electrical components so you can provide sufficient electricity to power them.

If your usage is not known in advance: The National Electrical Code (NEC) allows a maximum of 13 receptacles on each 20-amp circuit. This provides up to 30 receptacles for each 3-circuit power-in.

If your usage is known in advance:

Add up the amperage used by each piece of equipment in the workstation. Whenever you reach 60 amps (20 amps times 3 circuits) from items that are likely to be used at the same time, you have reached the limit for a single power-in. Specify another power-in and continue until all equipment is powered.

If the circuits will normally be subject to a continuous load (three or more hours of continuous use, such as lights or computers), the NEC requires that circuit capacity be "de-rated" by 20 percent. Therefore, treat circuits used for continuous loads as if they were rated at 16 amps instead of the regular 20 amps.

Try to anticipate future increases in power requirements and build some excess capacity into your plan.

▶ See table at right for typical and actual amperage usages for components.

To calculate amperage when the wattage of a device is known, divide watts by 120.

Some appliances, such as large copiers, coffee makers, or space heaters require most of the current available on a 20-amp circuit. It is recommended that such devices be supplied with their own receptacle/circuit, directly from the building. This leaves the capacity of the furniture circuits available for the more dynamic requirements of the office equipment.

Local electrical codes vary. Consult a qualified electrical contractor or engineer for the proper planning of electrical circuits in your locale.

Approximate power consumption for common devices

• Device	• Wattage	• Amperage	• Voltage	• Number of Devices Supported on Single 20 Amp Circuit
Laptop (Low)	30	0.25	120	64
Laptop (High)	100	0.83	120	19
CPU/Desktop Computer (Low)	65	0.54	120	30
CPU/Desktop Computer (High)	150	1.25	120	13
Monitor (Low)	15	0.13	120	128
Monitor (High)	80	0.67	120	24
Phone	5	0.04	120	384
High Power Tablet	10	0.08	120	192
Lower Power Tablet	45	0.38	120	43
Desktop Printer	40	0.33	120	48
42" LCD Screen	120	1.00	120	16
Projector (Small)	50	0.42	120	38
Projector (Medium)	250	2.08	120	8
Projector (Large)	800	6.67	120	2
Desktop Lamp	20	0.17	120	96
Large Printer/Copier	1600	13.33	120	1
Small Printer/Copier	800	6.67	120	2
Paper Shredder (Small)	250	2.08	120	8
Paper Shredder (Large)	800	6.67	120	2
Desktop Fan	25	0.21	120	77
Standing Fan	125	1.04	120	15
Coffee Maker (Low)	500	4.17	120	4
Coffee Maker (High)	1500	12.50	120	1
Microwave (Low)	600	5.00	120	3
Microwave (High)	1000	8.33	120	2
Refrigerator (Low)	200	1.67	120	10
Refrigerator (High)	1500	12.50	120	1
Vacuum (Low)	200	1.67	120	10
Vacuum (High)	1500	12.50	120	1
Space Heater (Low)	400	3.33	120	5
Space Heater (High)	1500	12.50	120	1
Height-Adjustable Desk (Low Power Consumption)*	200	1.67	120	10
Height-Adjustable Desk (High Power Consumption)*	550	4.58	120	3

Tip: These calculations are estimations and are meant solely for informational purposes. It is important to conduct proper power planning for each installation to prevent overloading a circuit.

** Refer to the Height-Adjustable Desks Specification Guide for specific product information.*

Cable Capacities

Test and verify capacities for your individual situation. We recommend that testing be conducted using your specific cable, as well as the furniture configuration you are considering. Cable capacities in this table are based on actual cable studies performed by an independent contractor following EIA/TIA codes and practices and can be taken as an accurate assessment of maximum practical capacity. Actual cable capacities may vary slightly depending on which manufacturer produced the cable and the specific field conditions.

Cable capacities are based on Category 6 and Category 6a cables at 55% fill capacity for cable study performed on junctions manufactured on or after October 10, 2011.

Note: Tests were performed on junctions with tall sleeves installed.

Cables Tested

A **CommScope**
Systemax Gigaspeed
1071E Series
Category 6 Cable
OD=0.23"

B **CommScope**
Systemax X10D
1091B Series
Category 6A Cable
OD=0.285"

Power harnesses reduce cable capacity.

An average of 10-15 cables will be reduced per harness used. However, this number varies according to installation practices and the type of cables used.



If glass window is used at the top of a panel, top cap lay-in cable capacity is 20 for category 6 cables.

When laying cables vertically behind skins, capacity is dependent on skin width.

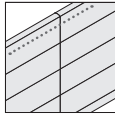
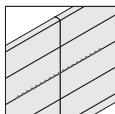
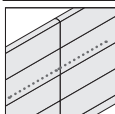
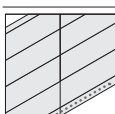
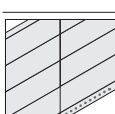
When using stacking junctions, the fork connector does not reduce cable capacity.

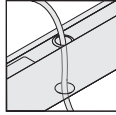
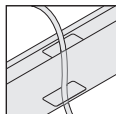
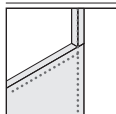
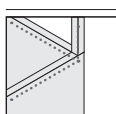
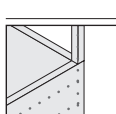
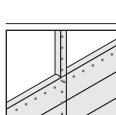
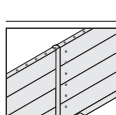
		A	B
Straight Horizontal Routing			
	Lay-in cable routing at top of panel (in-line junction)	40	30
	Horizontal pass-through (straight) at cable routing opening (available every 12" inside frame)	12	7
	Horizontal pass-through (straight) at rectangular opening for modular power harness (available every 12" inside frame)	72	47
	Lay-in cable routing at base of panel with power	36	22
	Lay-in cable routing at base of panel without power or with power harness routed above ▶ Page 90	48	30

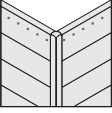
		A	B
Straight Vertical Routing			
	Vertical cable routing through round openings of horizontal connecting bars; two locations per bar	11	7
	Vertical cable routing through rectangular openings of horizontal connecting bars; two locations per bar	24	16
	Vertical cable routing inside junction utility pole (used on square and oval in an end, L or T configuration or on thin in an end)	48	39
	Vertical cable routing inside thin trim utility pole and exiting via top cable lay-in area	42	34
	Vertical cable routing inside thin trim utility pole and exiting into the panel in openings below the top lay-in area	50	40
	Vertical cable lay-in in a ceiling-access lay-in utility package	100	98
	Vertical cable lay-in in a floor-access lay-in utility package	80	54

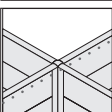
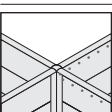
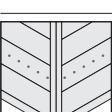
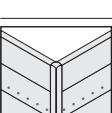
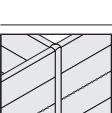
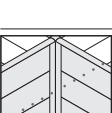
	A	B
L, T, X, V, and Y Horizontal Routing		
 Lay-in cable routing at top of panels in L or V configuration	16	11
 Lay-in cable routing at top of panels in T configuration	30	20
 Lay-in cable routing in top of panels in X or Y configuration	30	20
 Lay-in cable routing (around the corner) at the top of a panel in T or X configuration	16	11
 Horizontal pass-through at cable routing opening (available every 12" inside frames in L or V configuration)	8	5
 Horizontal pass-through (corner) at rectangular opening for modular power harness	48	26
 Horizontal pass-through (straight) at cable routing opening (available every 12" inside frames in T configuration)	12	7
 Horizontal pass-through (straight) at cable routing opening (available every 12" inside frames in X or Y configuration)	12	7

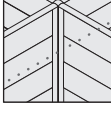
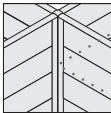
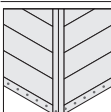
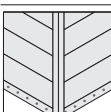
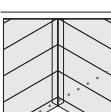
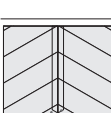
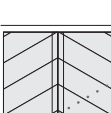
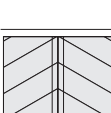
	A	B
L, T, X, V, and Y Horizontal Routing		
 Horizontal pass-through (straight) at rectangular opening for modular power harness (available every 12" inside frame)	72	47
 Horizontal pass-through (corner) at cable routing opening (available every 12" inside frames in T or X configuration)	8	5
 Lay-in cable routing (corner) at base of panel with power in L, T, or V configuration	14	9
 Lay-in cable routing (corner) at base of panel without power in L, T, or V configuration	14	9
 Lay-in cable routing (straight) at base of panel with power in X or Y configuration	36	22
 Lay-in cable routing (corner) at base of panel with power in X or Y configuration	11	6
 Lay-in cable routing (straight) at base of panel without power, or with power harness routed above in X or Y configuration ▶ Page 93	48	30
 Lay-in cable routing (corner) at base of panel without power, or with power harness routed above in X or Y configuration ▶ Page 93	14	9

Ceiling-Access Lay-In Utility Package

Ceiling-access lay-in utility packages allow panels to accommodate a large amount of power and cable brought in from the ceiling. Standard skins are used to finish the panel.
 ▶ Specifying, pages 348 and 421

Utility carrier routes power and cables from the ceiling into the panel. Carrier is integrated within a panel run and does not exceed the width of the panel.

Utility carrier and cover stop at top of junction so cables can go in either direction.

Standard horizontal connecting bars are used on adjacent panels. Cables routed vertically can be laid behind panel skin or routed through the openings in the horizontal connecting bar. Power is routed vertically through the opening in the horizontal connecting bar.

Utility carrier and cover for thin is 96"H or can be field cut to size. Square and oval are adjustable from 60"H to 120"H. The pole's inside dimension is 3"D x 5⁵/₈"W.

Top cap is shortened to accommodate utility carrier and cover. Wood veneer is available as an option. Top cap is available in three styles - thin, square, or oval.

Narrow horizontal connecting bars allow modular harnesses and large bundles of cables to be routed vertically over the front of the bars.

Standard base trim is included with ceiling lay-in utility package.

Product Details

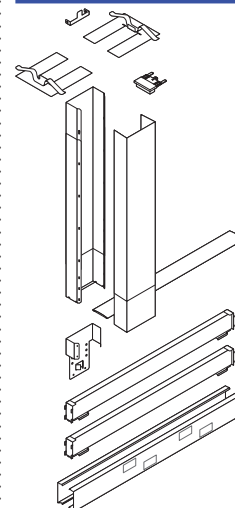

Ceiling-access lay-in utility package includes: utility carrier and cover with hardware, top cap, two lay-in horizontal connecting bars, and two base trims. Package is available in 30", 36", 42", and 48" widths to match standard panel widths. Package can be specified with thin, square, or oval top trim. Base cable trays are optional.

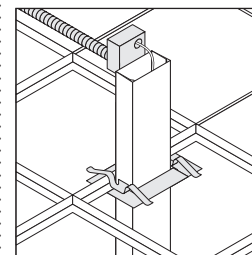

Ceiling attachment carrier and kit secures the top of the utility carrier and cover to the suspended ceiling grid. Hardwired connection to the building's power can be made in the junction box.

Ceiling-access lay-in utility package takes the place of a standard horizontal frame package. Don't double order.

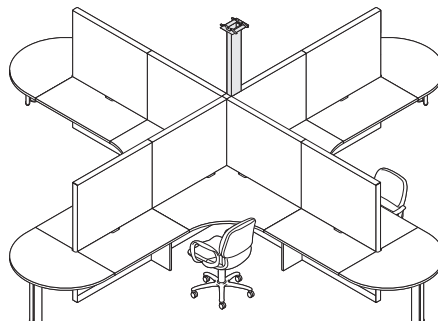
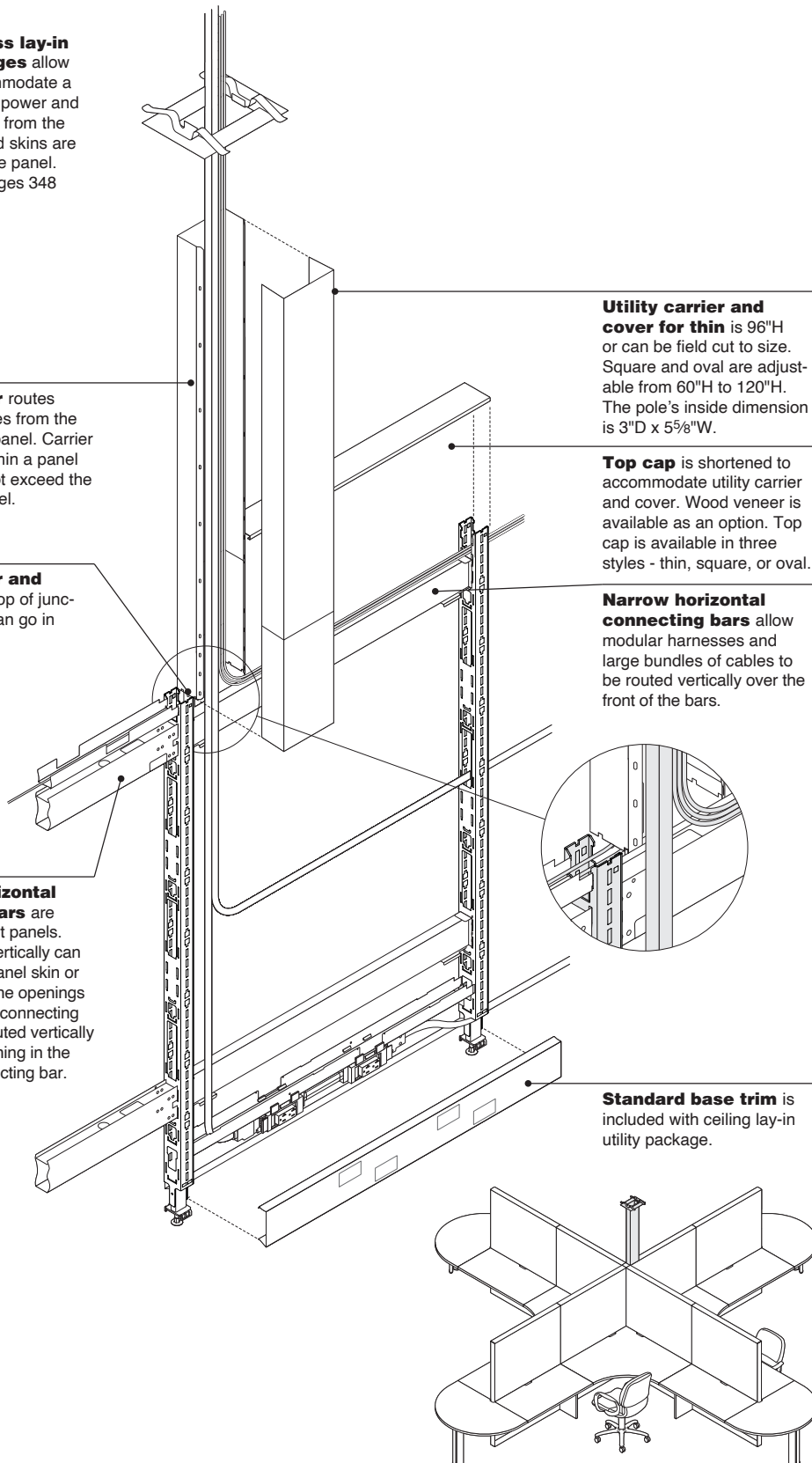

Connections

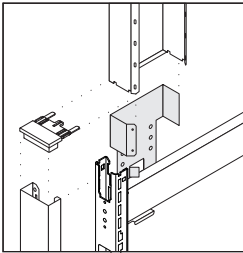

Bracket attaches the utility carrier to the lay-in horizontal connecting bar.

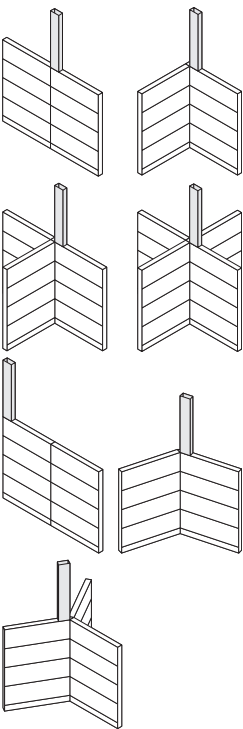

Ceiling-access lay-in utility package can be installed in in-line, L, T, X, V, Y, and end-of-run panel configurations. End-of-run condition reduces cable capacity.

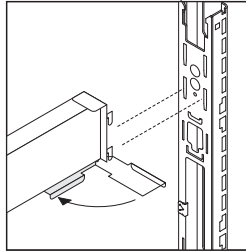

Quick-lock mechanism on the lay-in horizontal connecting bar engages the junction in a tight structural connection. Quick-lock mechanism is the same as on the standard horizontal connecting bars.

Wiring & Cabling

Local electrical codes vary. Consult a qualified electrical contractor or engineer for the proper installation of all electrical components.

Ceiling-access lay-in utility package was designed to be used with Answer power harnesses. If using any other type of conduit, the diameter of the conduit cannot be greater than 1/2". Skins will not install properly if conduit exceeds 1/2".

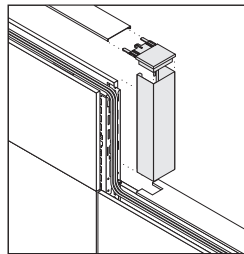

Square and oval change-of-height cable routing trim allows lay-in cable routing in change-of-height applications. Specify change-of-height top cap for the lower panel to allow clearance.

Power harness, ordered separately, acts as a shield to permit the ceiling-access lay-in utility package to accommodate power and communication cable routing at the same time.

Surface Materials

Utility carrier and cover, base trim, and top cap

- Paint
- Wood veneer (option on top cap only)

Lay-in horizontal connecting bars

- Black paint
- Tip: Components are hidden when panel is properly installed.*

Oval junction cap

- Plastic
- Tip: Junction cap is included for end-of-run configurations.*

Square junction cap

- Paint
- Tip: Junction cap is included for end-of-run configurations.*

Application Topics

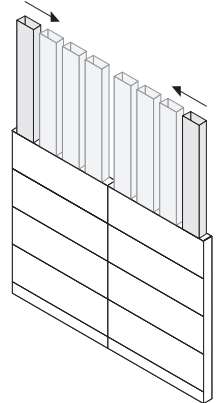

Utility carrier and cover are designed to be located at either end of the panel. However, they can be installed in any location, but field cutting of the top cap will be required.

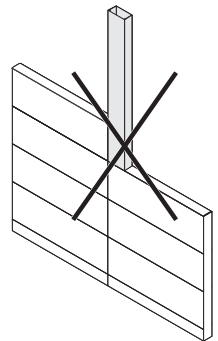

Utility carrier and cover cannot be located next to a taller panel.

Back-to-back slatwall skins cannot be installed at the top of a panel when using a ceiling access lay-in utility package. Slatwall can be used on one side only.

Windows cannot be installed in the top position of a lay-in frame.

Floor-Access Lay-In Utility Package

Floor-access lay-in utility packages allow panels to accommodate a large amount of power and cable brought in from the floor. Standard skins are used to finish the panel.
▶ Specifying, pages 349 and 422

Narrow horizontal connecting bars allow modular harnesses and large bundles of cables to be routed vertically over the front of the bars.

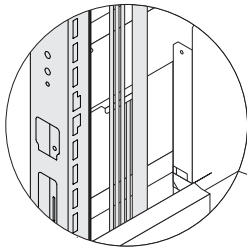

Base utility box covers power and cables entering from the floor.

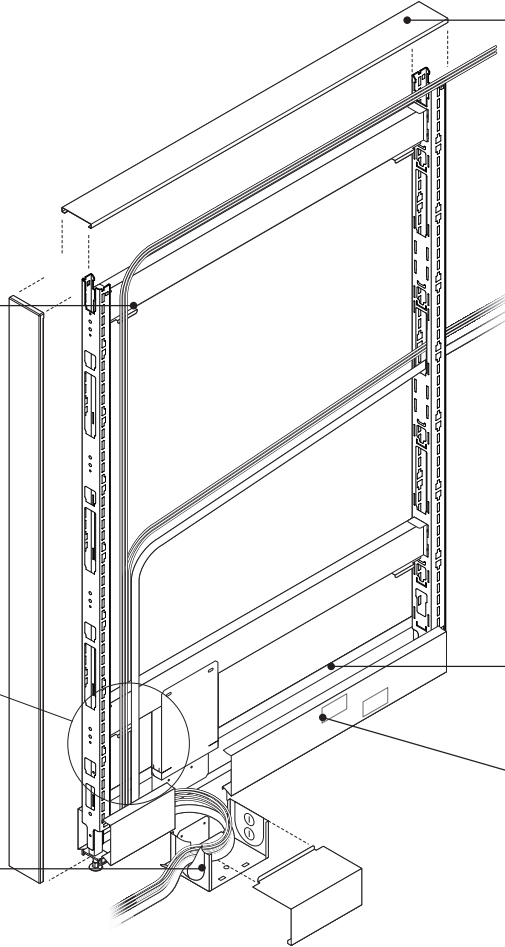

Standard top cap is included with floor-access lay-in utility package. Top cap is available in three styles - thin, square, or oval. Wood veneer is available as an option.

Standard base trim is included and used on the side of the panel opposite from the base utility box.

Modified base trim is included and consists of two pieces to allow attachment of base utility box.

Product Details

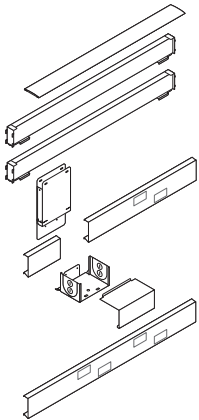

Floor-access lay-in utility package includes: top cap, two lay-in horizontal connecting bars, base utility box with hardware, one standard base trim, and one modified base trim. Package can be specified with thin, square, or oval top trim. It is available in 30", 36", 42", and 48" widths to match standard panel widths.

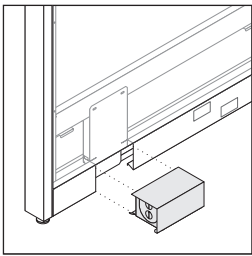

Base utility box is positioned at the left-hand side of the modified base trim. Entry on the other end would be accomplished from the other side of the panel.

Floor-access lay-in utility package takes the place of a standard horizontal frame package. Don't double order.

Connections

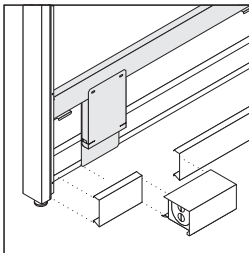

Bracket attaches the base utility box to the lower lay-in horizontal connecting bar.

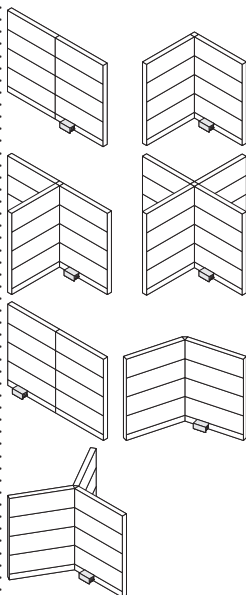

Floor-access lay-in utility package can be installed in in-line, L, T, X, V, Y, and end-of-run panel configurations. End-of-run condition reduces cable capacity.

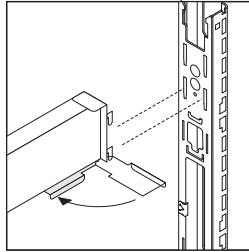

Quick-lock mechanism on the lay-in horizontal connecting bar engages the junction in a tight structural connection. Quick-lock mechanism is the same as on the standard horizontal connecting bars.

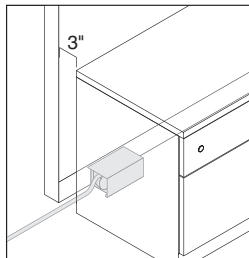

Power infeed sits proud of the panel approximately 3" and will interfere with Universal storage with the Universal 3" base, FrameOne foot base, or c:scape glide.

Wiring & Cabling

24"W powerkit, ordered separately, can be used in the base of 36"W, 42"W, and 48"W floor-access lay-in utility packages. Power kit must be located to the right of the base utility box. No powerkit can be used in 30"W floor-access lay-in utility packages.

Power harness, ordered separately, is shielded to permit the floor-access lay-in utility package to accommodate power and communication cable routing at the same time.

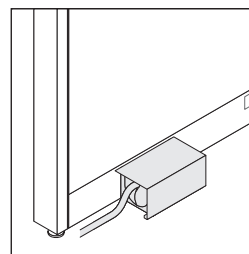

Base utility box routes cables and/or Answer harnesses into the panel from the floor. Base power infeeds are not intended for use with the floor-access lay-in utility package.

Floor-access lay-in utility package can accommodate up to 80 cat 6 cables. Deduct 10-15 cables for each power harness or modular connector routed through the base utility box.

Surface Materials

Base utility box, base trim, and top cap

- Paint
- Wood veneer (option on top cap only)

Lay-in horizontal connecting bars

- Black paint
- Tip: Bars are hidden when panel is properly installed.*

Application Topics

Base utility box protrudes 4" from the base trim on one side of the panel. When planning, locate the base utility box underneath a workstation instead of a hallway.

Specify change-of-height top cap on your lay-in utility package if it is the lower panel in a change-of-height configuration.

Base utility box is for routing of cable and power only. Not to be used as a termination point or for the routing of power cords.

Utility Pole—Thin Trim

Utility pole—thin trim brings power and cabling from the ceiling and introduces it into a panel with thin trim only through openings positioned vertically every 12". Junction is not included as utility pole connects into the existing panel junction (used with junctions manufactured on or after October 10, 2011).
▶ Specifying, page 347

Utility pole is flush with the footprint of the panel.

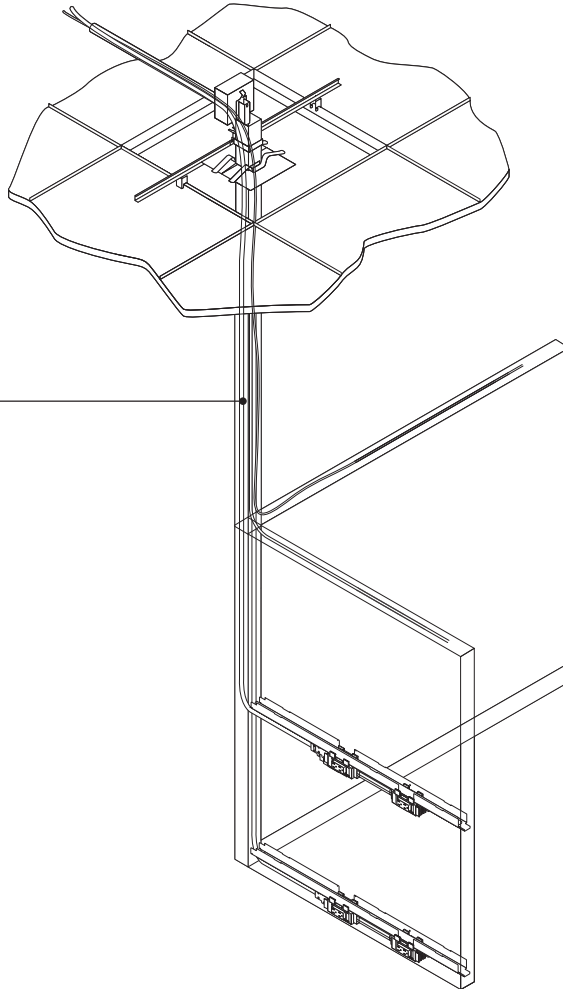

Product Details

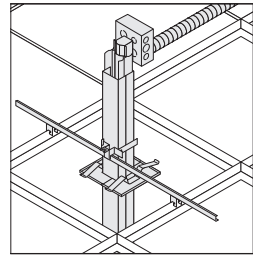

Ceiling attachment kit secures the top of the utility pole to the suspended ceiling grid. Hardwired connection to the building's power can be made in the junction box.

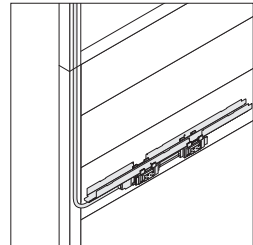

Power harness for use with utility pole is available to bring power down from the ceiling and into the panel to make a modular connection to a power kit.
Tip: Power harnesses are ordered separately from the utility pole.

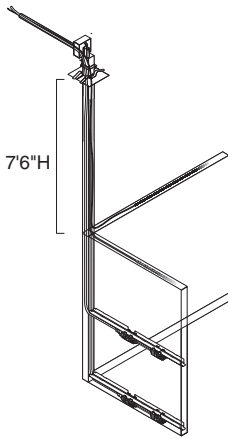

Utility pole can reach ceilings 7'6" higher than connection point (two panels at the highest height) of the panels.

Shield on power harness permits a utility pole to accommodate power and communication cable routing at the same time. For applications where more cable routing is needed, you can use the utility pole without a power harness or use a lay-in utility package.

Connections

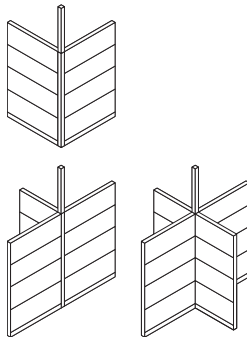

Utility pole—thin trim works with base and stacking junctions. It can be used at an L, T, or X configuration. It cannot be used in an end-of-run, V, Y, or in-line configuration. Utility pole is not shipped with a junction.

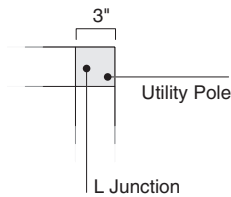

"L" application requires two panels at the same height. Utility pole is flush with the panel run.

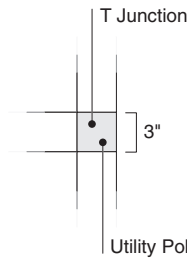

"T" application requires at least two panels at the highest height. Utility pole is flush with the panel run.

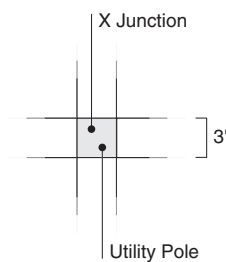

"X" application requires two panels at the same height. Δ

Wiring & Cabling

Three wiring schematics are available—3+1, 2+2, and three circuits with separate neutrals (3SN). All the components in an electrical distribution system must use the same wiring schematic. For safety the components are keyed, labeled, and color-coded to make it impossible to connect mismatched parts.

All Answer electrical components are listed by Underwriters Laboratory (UL) and certified by the Canadian Standards Association (CSA).

Local electrical codes vary. Consult a qualified electrical contractor or engineer for the proper installation of all electrical components.

Chicago and New York have special requirements.

Junction with Utility Pole

Utility pole brings power and cabling from the ceiling and introduces it into the panel through openings positioned vertically every 12 inches. Includes a junction and replaces the need to order one separately.
 ▶ Specifying, page 418

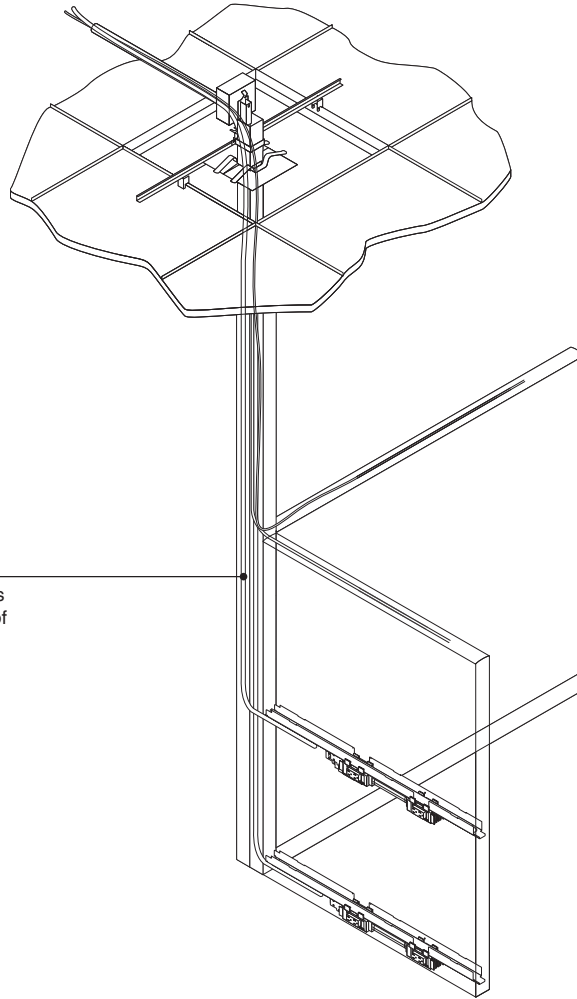

Utility pole extends beyond the footprint of the panel.

Product Details

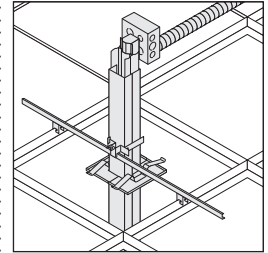

Ceiling attachment kit secures the top of the utility pole to the suspended ceiling grid. Hardwired connection to the building's power can be made in the junction box.

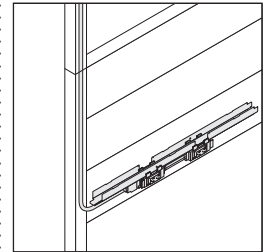

Power harness for use with utility pole is available to bring power down from the ceiling and into the panel to make a modular connection to a powerkit.
Tip: Power harnesses are ordered separately from the utility pole.

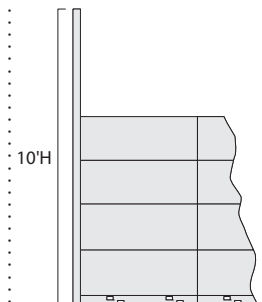

Ceiling heights up to 10' can be accommodated.

Shield on power harness permits a utility pole to accommodate power and communication cable routing at the same time. For applications where more cable routing is needed, you can use the utility pole without a power harness or use a power harness or use a lay-in utility package.
 ▶ Pages 348 and 420 for lay-in utility package.

Connections

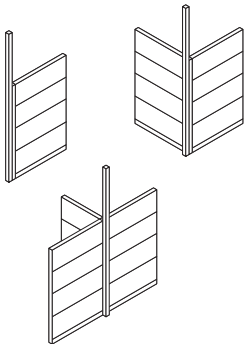

Utility pole works with base and stacking junctions. It can only be used at an end-of-run, in-line, L- or T-configuration. It cannot be used in an X, V, or Y-configuration. Utility pole is always shipped with a junction, so don't double order.

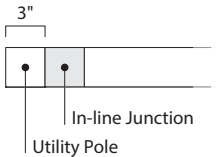

End-of-run application uses an in-line junction. Utility pole extends 3" beyond the footprint of the panels. This works with thin, square, or oval trim.

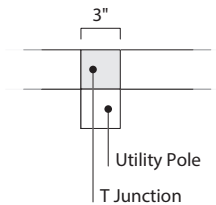

In-line application uses T junction and adds 3" to panel run. This works with square or oval trim only.

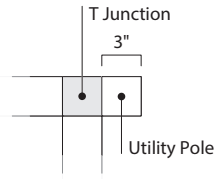

"L" application uses T junction. Utility pole extends 3" beyond the footprint of the panels. This works with square or oval trim only.

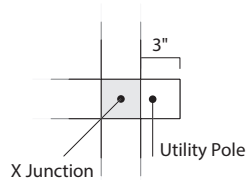

"T" application uses X junction. Utility pole extends 3" beyond the footprint of the panels. This works with square or oval trim only.

Wiring & Cabling

Three wiring schematics are available—3+1, 2+2, and three circuits with separate neutrals (3SN). All the components in an electrical distribution system must use the same wiring schematic. For safety the components are keyed, labeled, and color-coded to make it impossible to connect mismatched parts.

▶ Page 161

All Answer electrical components are listed by Underwriters Laboratory (UL) and certified by the Canadian Standards Association (CSA).

Local electrical codes vary. Consult a qualified electrical contractor or engineer for the proper installation of all electrical components.

Chicago and New York have special requirements.
▶ Pages 175 and 180

Base Power Infeed

Base power infeed connects power in the building floor to a powerkit in the base of a panel. Infeed occupies one receptacle opening.

► Specifying, page 489

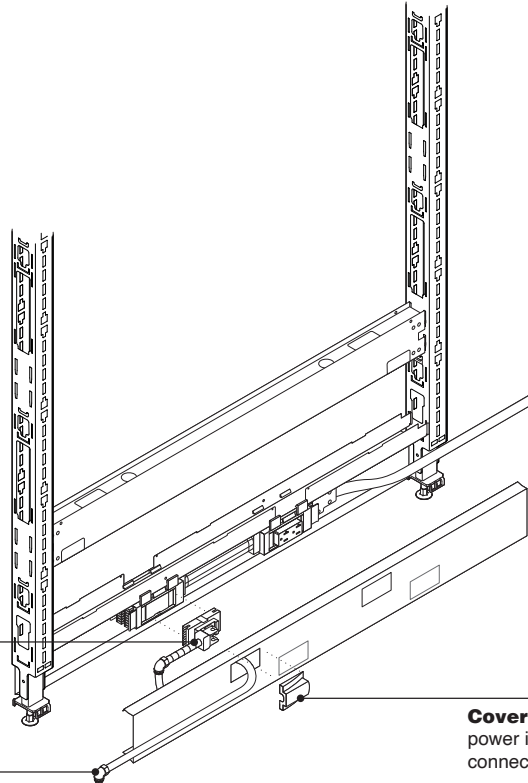

Connector on end of base power infeed harness occupies one receptacle location in power block.

Flexible harness makes hardwired connection to building monument. The harness must be backfed through the base trim prior to connection into the building monument.

Cover is included with base power infeed to conceal the connection.

Wiring & Cabling

Connector on base power infeed must be placed behind panel base trim and harness must be backfed through base trim opening prior to an electrician making the connection to power in the building floor.

Three wiring schematics are available—3+1, 2+2, and three circuits with separate neutrals (3SN). All the components in an electrical distribution system must use the same wiring schematic. For safety the components are keyed, labeled, and color-coded to make it impossible to connect mismatched parts.

► Page 161

All Answer electrical components are listed by Underwriters Laboratory (UL) and certified by the Canadian Standards Association (CSA).

Local electrical codes vary. Consult a qualified electrical contractor or engineer for the proper installation of all electrical components.

Panel segments with big open base cannot use base power infeed. Bring power in using a multi-purpose infeed.

Special requirements are needed for San Francisco.

► See page 489 for specification.

Special Requirements for New York City

New York City electrical code requires modular power components to be field installed by the electrician. Because Answer power components are always field installed, they are okay for use in New York.

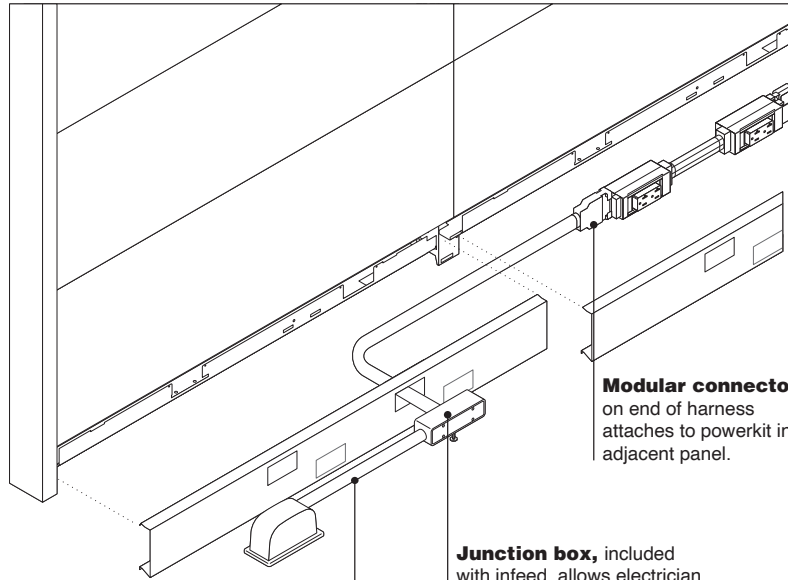

Modular connector on end of harness attaches to powerkit in adjacent panel.

Junction box, included with infeed, allows electrician to make a hardwire connection to the building power supply. Box covers opening in base cover.

Conduits supplied by electrician.

Order New York City power infeed with the width that corresponds to the width of the panel it will be installed in.
Tip: Remember that the panel with the New York City power infeed installed cannot accommodate any receptacles in the base because a powerkit cannot be installed. Install a powerkit higher in the panel to accommodate receptacles or use adjacent panels to install receptacles.

Distribution Products

Powerkits are a combination of modular power blocks, harnesses, and connectors that attach to a power tray for installation inside an Answer panel. Powerkits are available in widths that correspond to panel widths.

► Specifying, page 482

Powerkits may be specified in a non-PVC version. For those trying to gain the LEED Innovation in Design credit, non-PVC should be selected.

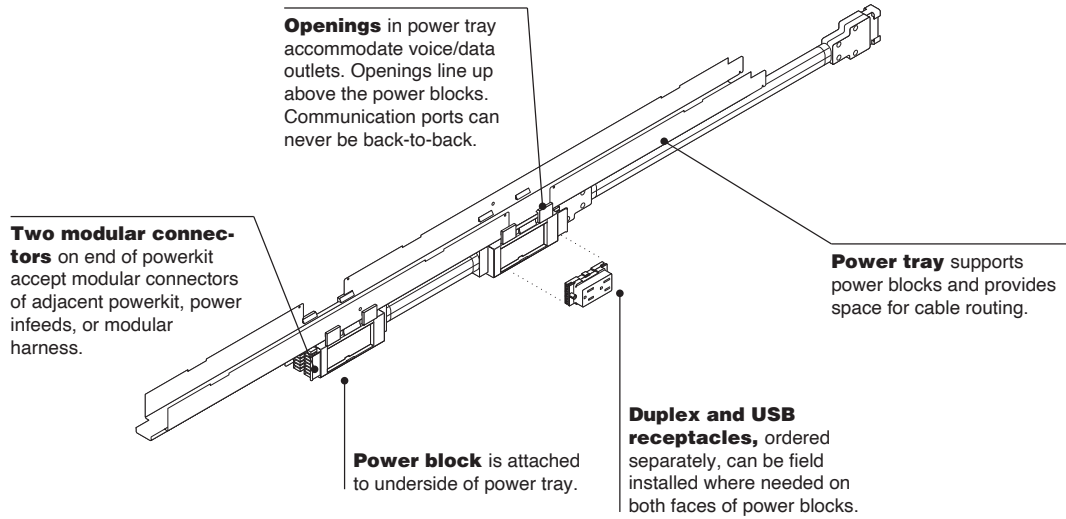

Pass-through powerkits are available for applications where you want to extend the power between panels but have no need for access in a specific panel.

► Specifying, page 483

Pass-through powerkits may be specified in a non-PVC version. For those trying to gain the LEED Innovation in Design credit, non-PVC should be selected.

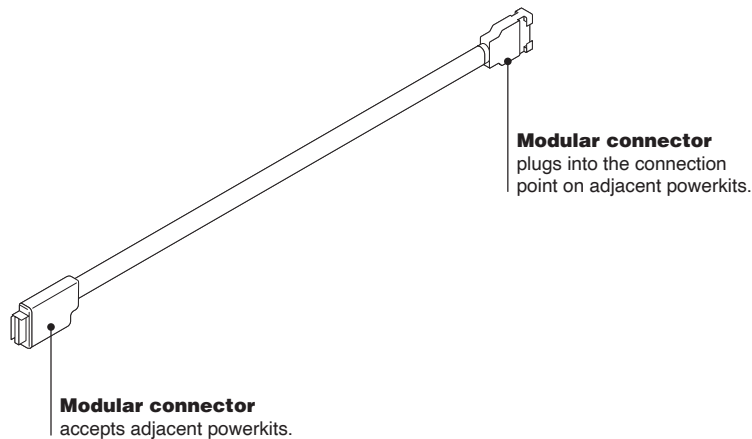

Cable trays can be installed every 6" vertically and rearranged at various heights within a panel for communications access and cable routing.

► Specifying, page 481
Exception: Cable tray cannot be used in the base of the panel.

Cable tray can accept added cable carriers attached below tray to expand horizontal cable management options.
 ► See *Montage Specification Guide* for cable carrier (ZCC).

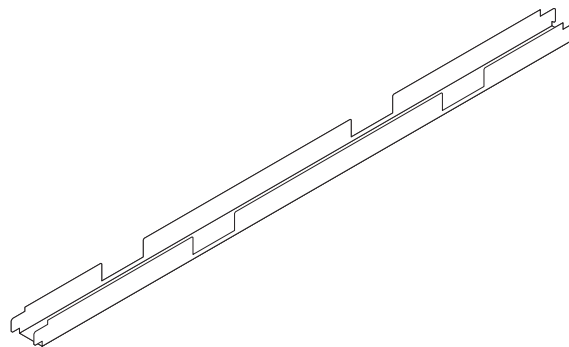

Product Details

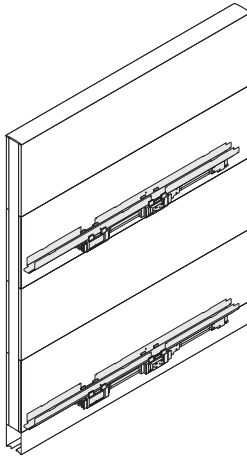

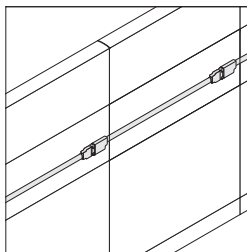

Powerkits can be installed every 12" vertically. Typically they are positioned in the panel base, at worksurface height, or in both locations.





Pass-through powerkits extend power between panels.

Standard Base Trim Width of panel application determines how many receptacle and communication locations are available.

12"

 24"W with one power block. Communication opening is located below and to the right of the power block.

12"

 30"W with two power blocks. Communication opening is located below and to the right of the right-hand power block.

12"

 36"W to 48"W with two power blocks. Communication openings are located below and to the right of each of the power blocks.

12"

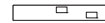
 60"W to 72"W with four power blocks. Communication openings are located below and to the right of each right-hand power block of each power block pair.

Tip: For non-base locations, same power block locations apply, but communication openings line up above the right-hand power block.

Hardwired Base Trim Width of panel application determines how many receptacle and communication locations are available.

12"

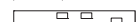
 24"W with one power block. Communication opening is located below and to the right of the power block.

10.3"

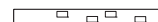
 30"W with two power blocks. Communication opening is located below and to the right of the right-hand power block.

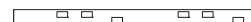
12"

 36"W with two power blocks. Communication opening is located below and to the right of the right-hand power block.

12"

 42"W to 48"W with two power blocks. Communication openings are located below and to the right of each of the power blocks.

12"

 60"W to 72"W hardwire powerkit comes with two power blocks. The hardware base trim has two power knockout options on each end of the base trim. The power block can be installed at either knockout location. Communication openings are located below and to the right of each right-hand power block of each power block pair.

Tip: For non-base locations, same power block locations apply, but communication openings line up above the right-hand power block.

Tip: Communication openings are located 2 1/2" further right than standard base trims to accommodate wider hardwired junction boxes.

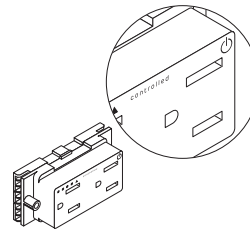

15-amp or 20-amp duplex receptacles snap into powerkits on one side or both sides of the panel.



Controlled receptacle must be indicated when tying into the building management system. Duplex receptacles have an option for a factory permanent, pad stamp power icon symbol with the word controlled per compliance with the Energy Code.



USB receptacles available in three wiring schematics with multiple line options, snap into powerkits on one side or both sides of the panel. USB receptacles offer easy access to two charging ports. Each port provides 1 ampere of output. USB receptacles conveniently charge a wide range of electronic devices. Some devices may not be compatible.

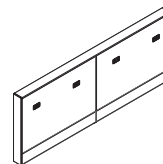

Power and data can be accessed in 24"H standard base, 24"H to the floor, and big open base steel skins by specifying power and data cutouts.

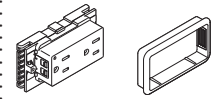

For power access in steel skins, specify **TS7RC** receptacles and **TS7RCT** trim rings for each power cutout specified in steel skins.

For USB power access in steel skins, specify **TS7USB** receptacles and **TS7RCT** trim rings for each power cutout specified in steel skins.

Receptacle fillers are available to fill unused receptacle openings in steel skins. Use **TSBRF**.

Data fillers are available to fill unused furniture style data openings. Use **TS7DF**.

Install duplex or USB receptacles only where you want them. Add more receptacles in the future. *Exception: When using technology skins, receptacles are required in all power block locations. Tip: If receptacles are not specified for all power block locations, you must order filler through Service Parts (891500350MP, package of 20).*

Three wiring schematics are available—3+1, 2+2, and three circuits with separate neutrals (3SN). All the components in an electrical distribution system must use the same wiring schematic. For safety the components are keyed, labeled, and color-coded to make it impossible to connect mismatched parts.

► Page 161

Distribution Products, continued

Performance tackable acoustical skins and tackable acoustical skins can be cut in the field to allow access to duplex receptacles, USB receptacles, and communication outlets. Order cutting templates through Service Parts (T500940SR). Steel skins do not have cutouts and cannot accommodate receptacles. Install power receptacles and communication ports in the panel base cover below the steel skin or use a technology skin.

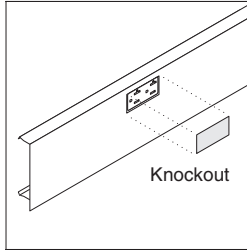

Knockouts and cut-outs for receptacles in the panel base trim and skins are always 10⁵/₈" from the outside edges of the panel. Knockouts for communication in base accommodate modular furniture size only.

Filler to close unwanted openings in base trim is available from Service Parts.

Wire separators are not required. All electrical harnesses are shielded.

Local electrical codes vary. Consult a qualified electrical contractor or engineer for the proper installation of all electrical components.

Chicago and New York have special requirements.
▶ Pages 175 and 180

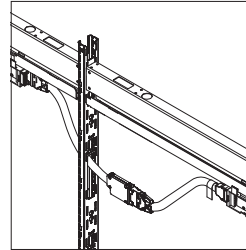

A pass-through harness is required when connecting powerkits in the top position of a 36"H or 48"H junction. A pass-through harness should be used for both in-line and corner applications.

Modular Harness

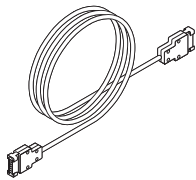

▶ Specifying, page 493

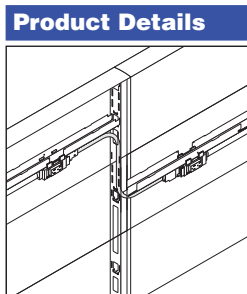

Modular harnesses are available to connect powerkits at different heights. Available in 43" and 80" lengths.

Extra length modular harness is required when connecting two power kits located at different heights inside the panel in a corner or in-line application.

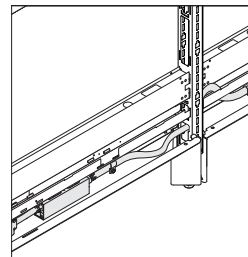

In an in-line application extra length modular harness is not required when a powerkit is in the bottom (not base) location in a panel with open base.

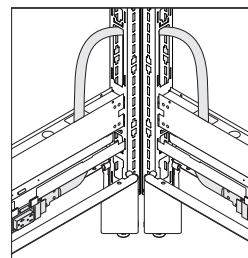

In a corner application extra length modular harness is required when a powerkit is in the bottom (not base) location in a panel with open base trim. In this circumstance, the modular harness will need to be routed through the first large opening in the junction located above the powerkit. The modular harness cannot be routed through the foot area of the panel due to the open base trim.

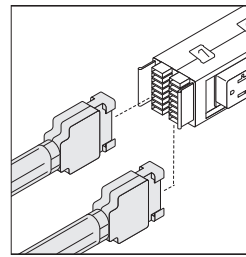

Harnesses plug into connection points on the powerkit. Every powerkit has multiple connection points to allow branching of power.

Modular harness may be specified in a non-PVC version.

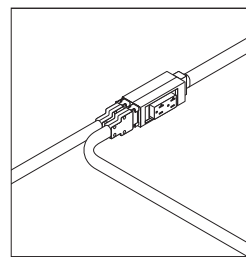

T-connection is formed by connecting two harnesses to a power block.

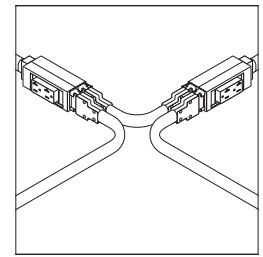

X-connection is formed by connecting two harnesses to two successive power blocks.

Modular harness may be specified in a non-PVC version. For those trying to gain the LEED Innovation in Design credit, non-PVC should be selected.

Multipurpose Power Infeed

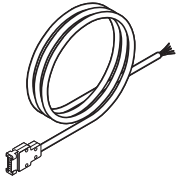

► Specifying, page 492

Product Details

Multipurpose power infeed is shielded to allow power and communication routing side by side. Available in 6', 12', and 24' lengths.

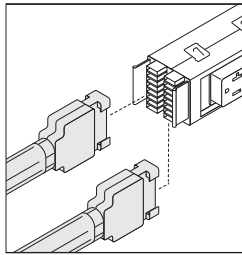

Multipurpose power infeeds bring power into the panel and make a modular connection to a powerkit.

Multipurpose power infeeds can be used with ceiling- and floor-access lay-in utility packages and utility poles. Specify power harness separately.

Multipurpose power infeeds may be specified in a non-PVC version. For those trying to gain the LEED Innovation in Design credit, non-PVC should be selected.

Special Requirements for Hardwired Solution

Chicago electrical code requires the power distribution network to be hardwired on site. These installations require hardwired powerkits.
 ▶ Specifying, page 491
Tip: Any hardwired installation can use the components of the hardwired powerkit.

Order panel without power and order a hardwired powerkit of the corresponding width.
 ▶ Page 491

Power tray is included in hardwired powerkit to secure junction boxes and to attach to panel frame.

When power is placed in a non-base application, skins must be field-cut. Technology skins cannot be used with hardwired solution.
Tip: Hardwire powerkit applications in the base location require a hardwire base trim for correct alignment of power and data receptacles.

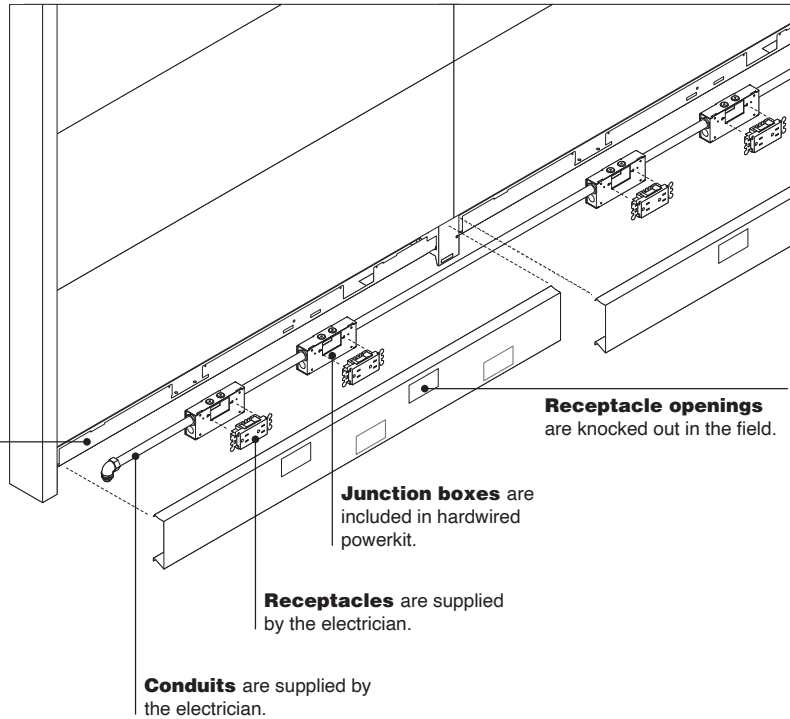

Connections

Powerkit can be installed in panel base or at 12" vertical increments.

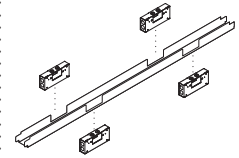

Junction boxes are typically mounted below the power tray; however, they can be mounted above when power is routed in a location other than the panel base. A bracket is included for mounting junction boxes above the powertray.

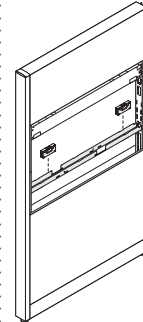

When using a hardwired solution with segmented skins, you may need to install junction boxes above the power tray to avoid interference with the steel frame of the skin. Approximately 3" of clearance is required when mounting junction boxes above the power tray. Keep in mind the upper horizontal connecting bar location to ensure enough space for mounting junction boxes above.

Tip: Don't forget to discuss junction box location and skin configuration prior to electrician installing the power.

Number of Junction Boxes is Determined by Panel Width

Panel width	Junction boxes
24"	1
30"	2
36"	2
42"	2
48"	2
60"	2
72"	2

Wiring & Cabling

Junction box can accommodate two receptacles back to back. Electrician can use Leviton 5325 or equivalent receptacles.

Order Chicago-version of shelf lights. These lights have a built-in circuit breaker.

Duplex Receptacles



► Specifying, page 484

Product Details

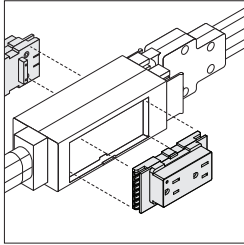

15-amp or 20-amp receptacles, ordered separately, snap into both faces of power block in the field.

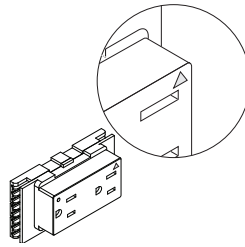

Orange triangle indicates to users the receptacles that are connected to isolated grounds.

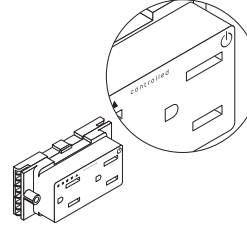

Controlled receptacle must be indicated when tying into the building management system. Duplex receptacles have an option for a factory permanent, pad stamp power icon symbol with the word controlled per compliance with the Energy Code.

For power access in steel skins, specify **TS7RC** receptacles and **TS7RCT** trim rings for each cutout.

Surface Materials

Duplex receptacle

- 6000 Black
- 6009 Arctic White
- 6249 Platinum Solid
- 6651 Tungsten
- 6652 Titanium
- 6654 Sand
- 6697 Fog
- 6B03 Red

USB Receptacles



► Specifying, page 486

Product Details

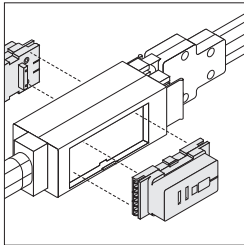

USB receptacles, ordered separately, snap into both faces of power block in the field.

USB receptacles are type USB-A.

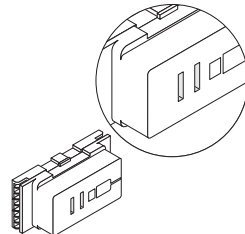

USB receptacles, are available in three wiring schematics with multiple line options. USB receptacles offer easy access to two charging ports. Each port provides one ampere of output. USB receptacles conveniently charge a wide range of electronic devices. Some devices may not be compatible.

For USB power access in steel skins, specify **TS7USB** receptacles and **TS7RCT** trim rings for each cutout.

Surface Materials

USB receptacle

- 6000 Black
- 6009 Arctic White
- 6249 Platinum Solid
- 6651 Tungsten
- 6652 Titanium
- 6654 Sand
- 6697 Fog
- 6B03 Red

Faceplate



► Specifying, page 487

Product Details

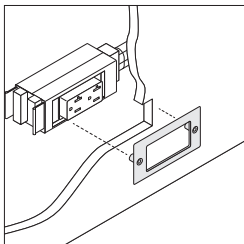

Faceplate, ordered separately, is used to surround receptacle when skin is field-cut. Templates for field cutting are available through Service Parts (T500940SR).

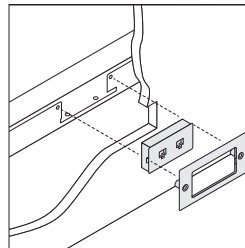

Faceplate is used to surround modular furniture size communication or DECORA outlets when installed in the face of a tackable acoustical panel skin. Templates for field cutting are available through Service Parts (T500940SR).

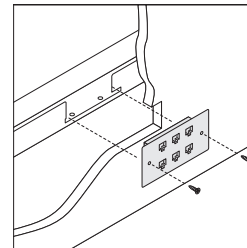

NEMA-size communication outlets (single gang) do not require a Steelcase faceplate. Cannot be used in base.

Surface Materials

Faceplate

- 6000 Black
- 6009 Arctic White
- 6249 Platinum Solid
- 6651 Tungsten
- 6652 Titanium
- 6654 Sand
- 6697 Fog

Receptacle Trim Ring



► Specifying, page 488

Product Details

Receptacle trim ring is used with each receptacle, receptacle cut-out cover, or USB on a steel skin to cover the edge of the cut-out and create a precise transition between the cut-out and the receptacle.

Trim ring will only work on receptacle **TS7RC**, **TS7USB**, and **TS7BCC**.

Only specify when using power cutouts in steel skins.

Surface Materials

Receptacle Trim Ring

- 6000 Black
- 6009 Arctic White
- 6249 Platinum Solid
- 6527 Merle
- 6654 Sand
- 6697 Fog

Receptacle Filler



► Specifying, page 488

Product Details

Receptacle fillers are available to fill unused receptacle openings in steel skins. They are offered in packages of 20.

Surface Materials

Receptacle Filler

- 6000 Black
- 6009 Arctic White
- 6249 Platinum Solid
- 6527 Merle
- 6654 Sand
- 6697 Fog

Data Filler



► Specifying, page 488

Product Details

Data fillers are available to fill unused furniture style data openings in steel skins. They are offered in packages of 20.

Surface Materials

Data Filler

- 6000 Black
- 6009 Arctic White
- 6249 Platinum Solid
- 6527 Merle
- 6654 Sand
- 6697 Fog

Accessories

Junction Tall Sleeve

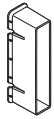

► Specifying, page 496

Product Details

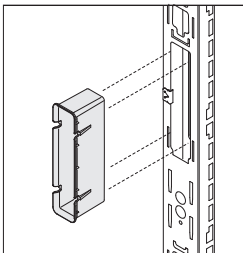

Junction tall sleeve can be added to vertical junctions to cover the exposed metal edges in the large cable routing openings of junctions manufactured on or after October 10, 2011.

Junction tall sleeves are ordered separate from vertical junctions and are available in packages of 10.

Surface Materials

- Red plastic only

Lay-In Junction Cable Sleeve

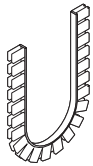

► Specifying, page 497

Product Details

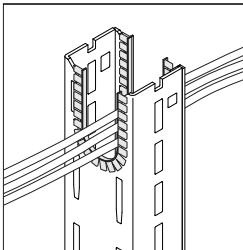

Lay-in junction cable sleeves can be added in the field to cover the exposed metal edges in lay-in cable space.

Surface Materials

Lay-in junction cable sleeve

- Black plastic only

Feed-Through Horizontal Cable Sleeve



► Specifying, page 497

Product Details

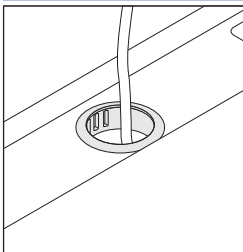

Feed-through horizontal connecting bar cable sleeves can be added in the field to finish the exposed metal edges of vertical cable pass-through openings.

Surface Materials

Feed-through horizontal cable sleeve

- Black plastic only

Grommet for Horizontal Bar and Junctions (manufactured prior to October 2011) and Horizontal Bars

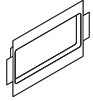

► Specifying, page 497

Product Details

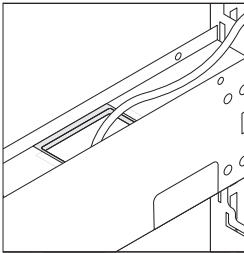

Grommet for horizontal bar and junctions can be added in the field to finish the exposed metal edges of cable pass-through openings. For cable sleeves used with junctions manufactured after October 2011, use junction tall sleeve (TS7JTSLVE).

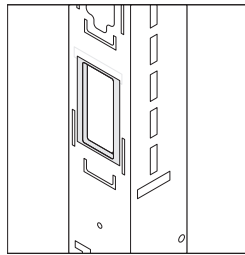

Grommets can also be used with power trays or cable trays.

Surface Materials

- Black plastic only

Grommet for Junction



► Specifying, page 498

Product Details

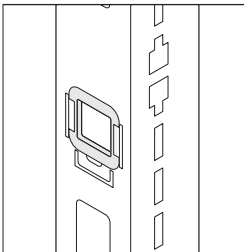

Grommet for junction can be added in the field to finish the exposed metal edges of horizontal cable pass-through openings.

Surface Materials

- Black plastic only

Duplex Cable Grommet

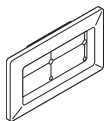

► Specifying, page 498

Product Details

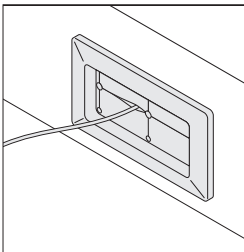

Cable grommets can be inserted in receptacle openings to route cables from the panel base into the panel.

Surface Materials

- Duplex cable grommet**
- 6000 Black
 - 6009 Arctic White
 - 6249 Platinum Solid
 - 6607 Woodrose
 - 6608 Driftwood
 - 6609 Smoke
 - 6612 Grey V2
 - 6655 Warm White
 - 6697 Fog
 - 66WU Clay
 - 66WV Chalk

Understanding Universal Systems Worksurfaces and Supports

	
Statement of Line	186

Worksurface Positioning	200
Panel-Mounted Worksurface Supports Integration Matrix	201
Worksurface Support Guidelines	202
Universal Worksurface Thought Starters	205
Universal Systems Worksurfaces	208
Universal Systems Worksurfaces with Soft Edge, Power and Data Access Door and Tray	212
Universal Systems Worksurfaces with Power Access Door	216
Worksurface-Mounted Retractable Power and Data	218
Metal Center Drawers	219
Transaction Worksurfaces	220
Universal Panel-Mounted Worksurface Supports	222
Off-Module Worksurface-to-Panel Connector	224
FrameOne Legs and Supports for Universal Worksurfaces	226
Infills for FrameOne Legs for Universal Worksurfaces	229
Legs and Columns for Universal Systems Worksurfaces	230
Knife Edge Worksurface Application Guidelines	232

Statement of Line

All worksurface sizes and shapes are available in High-Pressure Laminate with 3 mm edge. Most sizes and shapes are also available in wood veneer with square edge. See Specifying pages for details.

Worksurface dimensions shown apply to both wood veneer and High-Pressure Laminate versions of each worksurface.

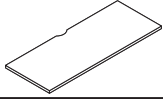

Understanding
 ▶ Page 208
 Specifying
 ▶ Page 500

Straight Worksurfaces

With 1/2" Cord Drop



Tip: Worksurfaces greater than 30"D can only be used in free-standing applications.

Tip: Modular dimensions displayed, parametric dimensions available in depths from 18" to 36" and widths from 18" to 120" in 1/16" increments both depth and width.

With Full Depth

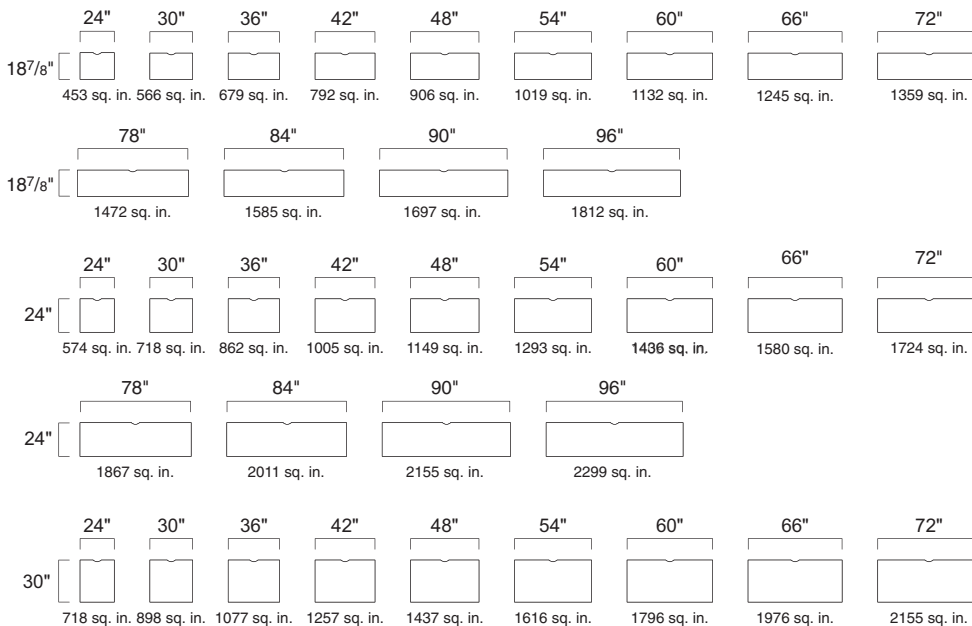

Tip: Modular dimensions displayed, parametric dimensions available in depths from 18" to 36" and widths from 18" to 120" in 1/16" increments both depth and width.

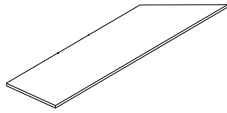

Understanding
 ▶ Page 208
 Specifying
 ▶ Page 512

Straight 120° Worksurfaces

With 1/2" Cord Drop

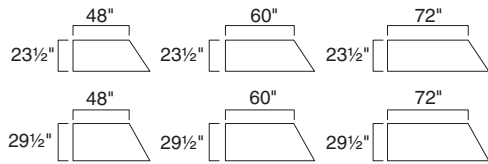

*Right-hand units shown.
 Left-hand units available.

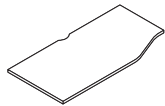

Understanding
 ▶ Page 208
 Specifying
 ▶ Page 514

Transition Worksurfaces*

With 1/2" Cord Drop

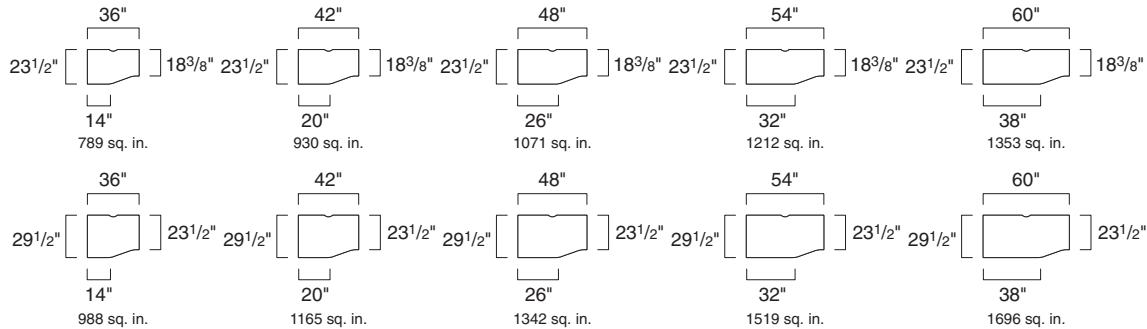

With Full Depth

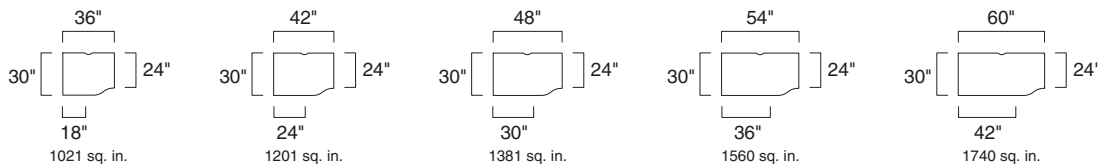

*Left-hand units shown.
 Right-hand units available.

Statement of Line, continued

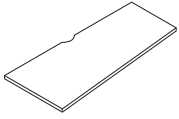

Understanding
 ▶ Page 208
 Specifying
 ▶ Page 516

Tapered Worksurfaces*

With 1/2" Cord Drop

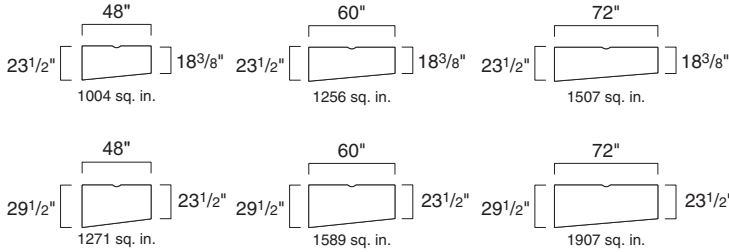

With Full Depth

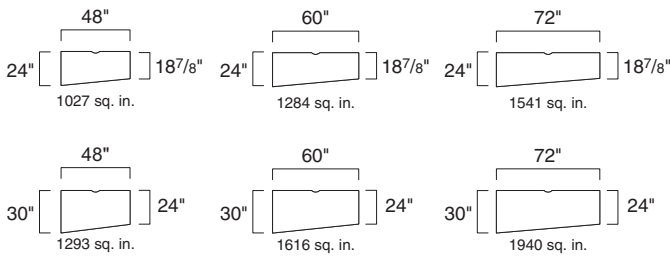

*Left-hand units shown.
 Right-hand units available.

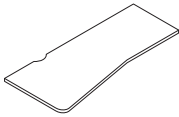

Understanding
 ▶ Page 208
 Specifying
 ▶ Page 517

Taper-Flat Worksurfaces*

With 1/2" Cord Drop

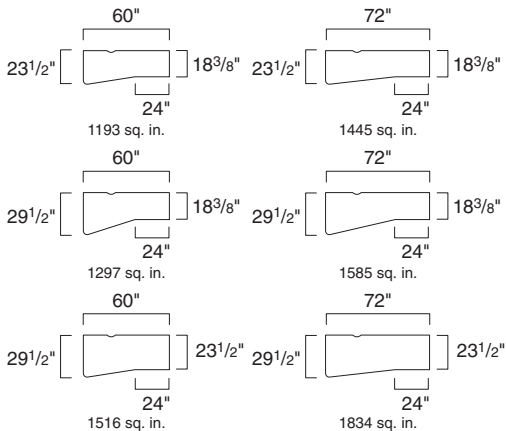

With Full Depth

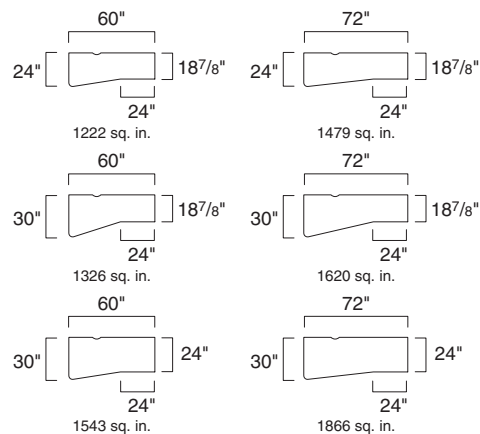

*Left-hand units shown.
 Right-hand units available.

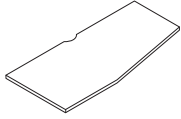

Understanding
 ▶ Page 208
 Specifying
 ▶ Page 518

Single-Tapered Worksurfaces*

With 1/2" Cord Drop

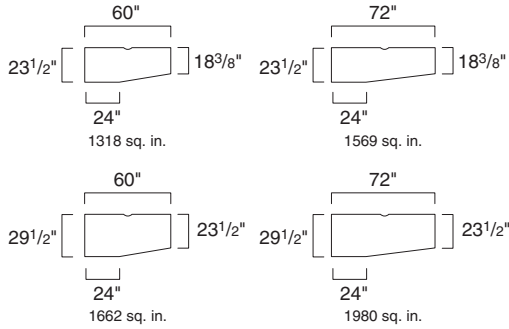

With Full Depth

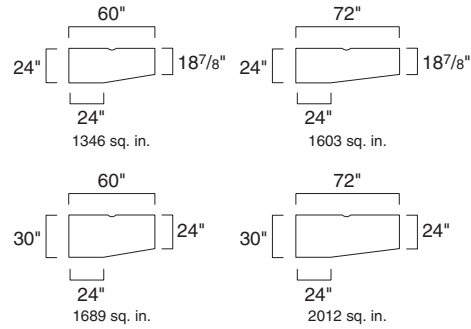

*Left-hand units shown.
 Right-hand units available.

Statement of Line, continued

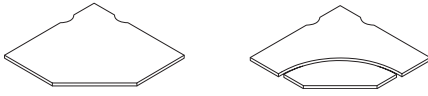

Understanding
 ▶ Page 208
 Specifying
 ▶ Page 519

Corner, Flat-Front Worksurfaces

Corner, Flat-Front Worksurfaces With 1/2" Cord Drop

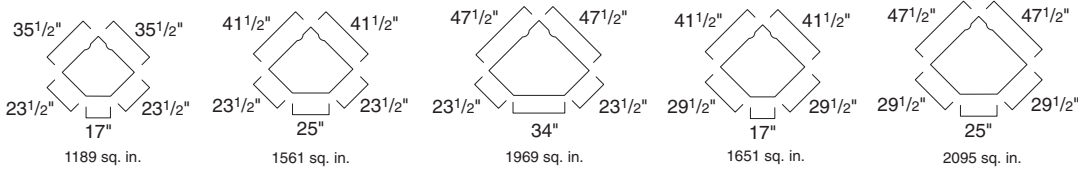

Dual Corner, Flat-Front Worksurfaces With 1/2" Cord Drop

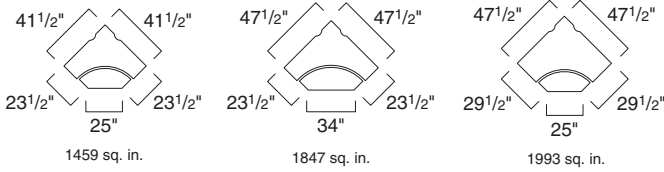

Corner, Flat-Front Worksurfaces with Full Depth

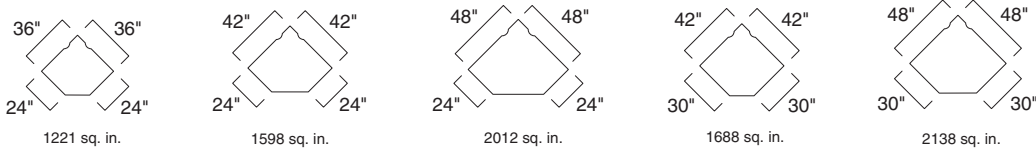

Dual Corner, Flat-Front Worksurfaces with Full Depth

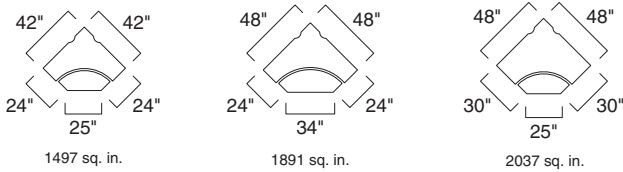



Understanding
 ▶ Page 208
 Specifying
 ▶ Page 521

Corner, Straight-Front Worksurfaces

Corner, Straight-Front Worksurfaces With 1/2" Cord Drop

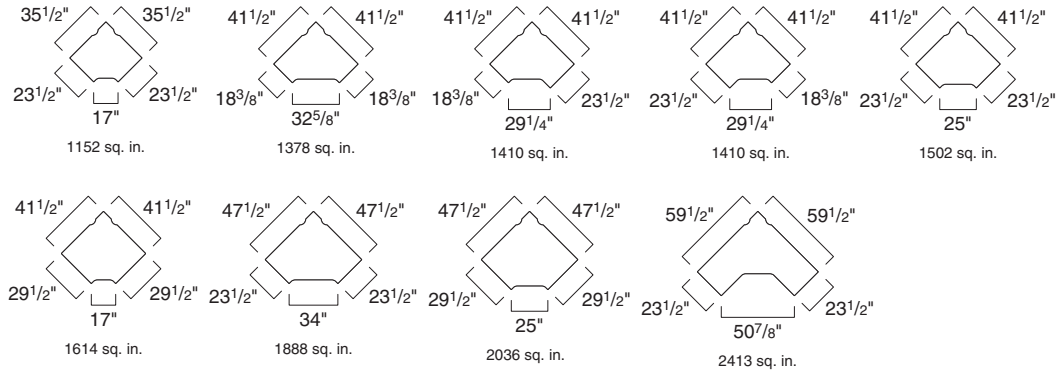

Statement of Line, continued



Understanding
 Page 208
 Specifying
 Page 522

Corner, Curved-Front Worksurfaces

With 1/2" Cord Drop

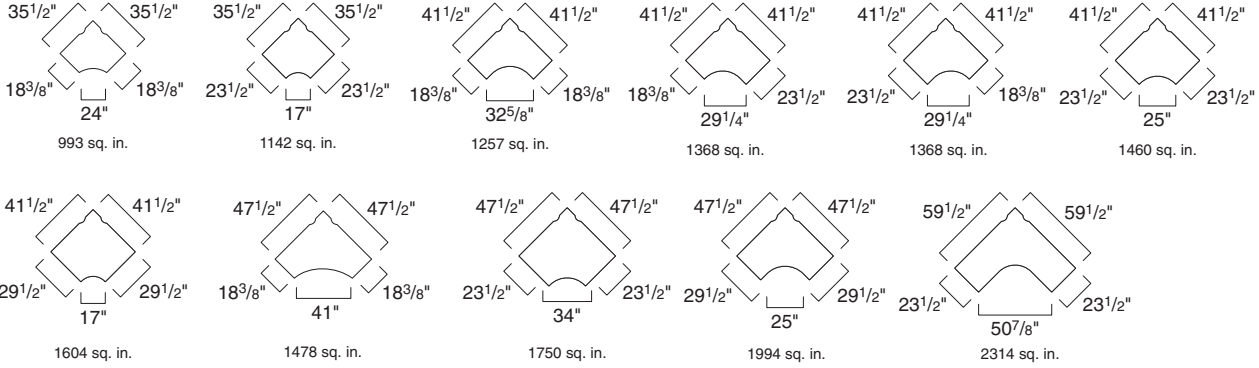

With Full Depth

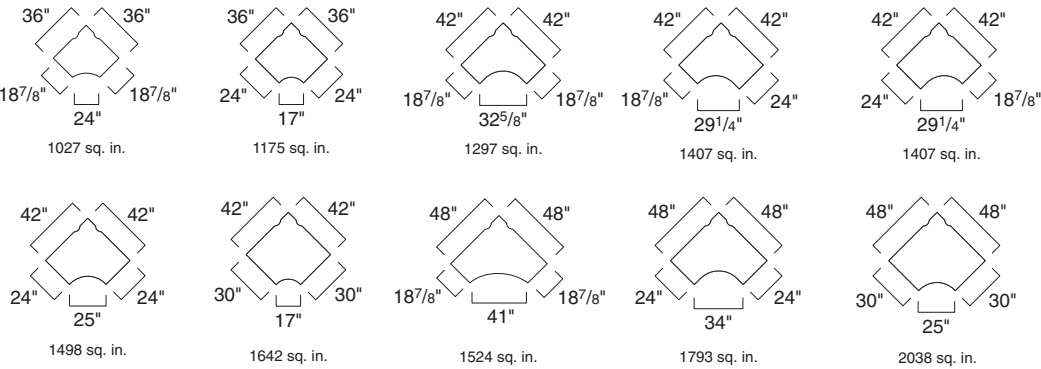

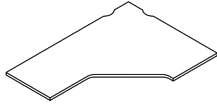

Understanding
 Page 208
 Specifying
 Page 524

Extended Corner, Straight-Front Worksurfaces*

Extended Corner, Straight-Front Worksurfaces With 1/2" Cord Drop

*Left-hand units shown.
 Right-hand units available.

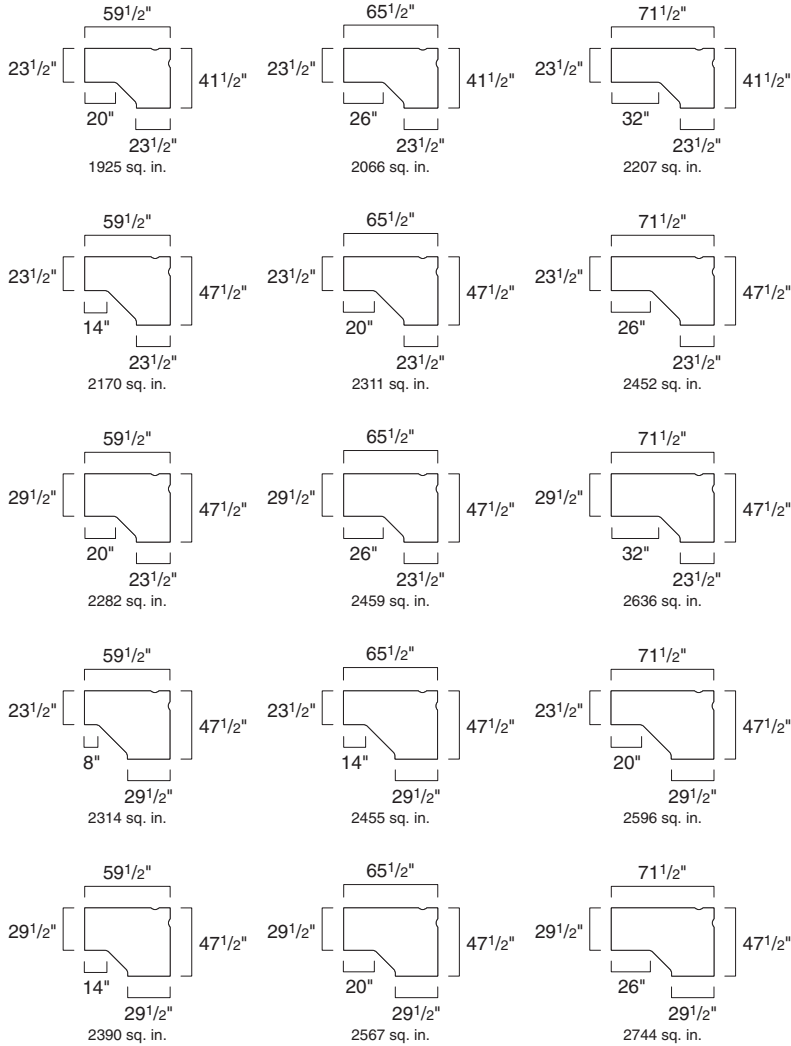

Statement of Line, continued



Understanding
 Page 208
 Specifying
 Page 526

Extended Corner, Curved-Front Worksurfaces*

With 1/2" Cord Drop

*Left-hand units shown.
 Right-hand units available.

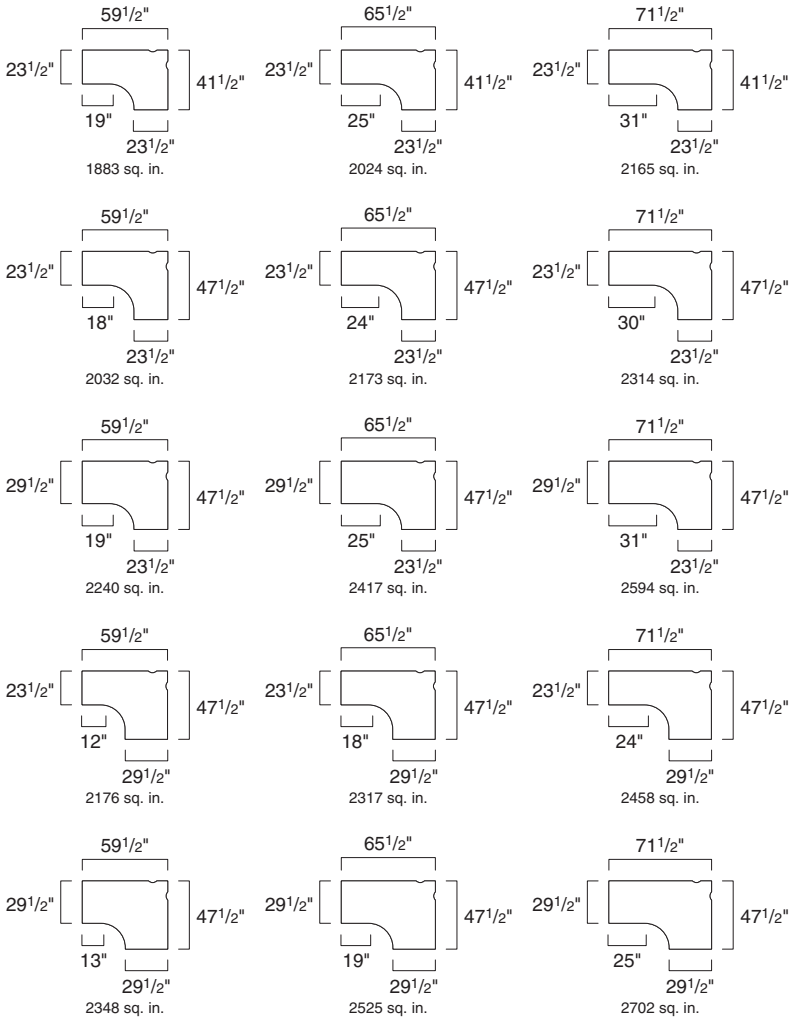

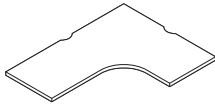

Understanding
 ▶ Page 208
 Specifying
 ▶ Page 526

Extended Corner, Curved-Front Worksurfaces*

With Full Depth

*Left-hand units shown.
 Right-hand units available.

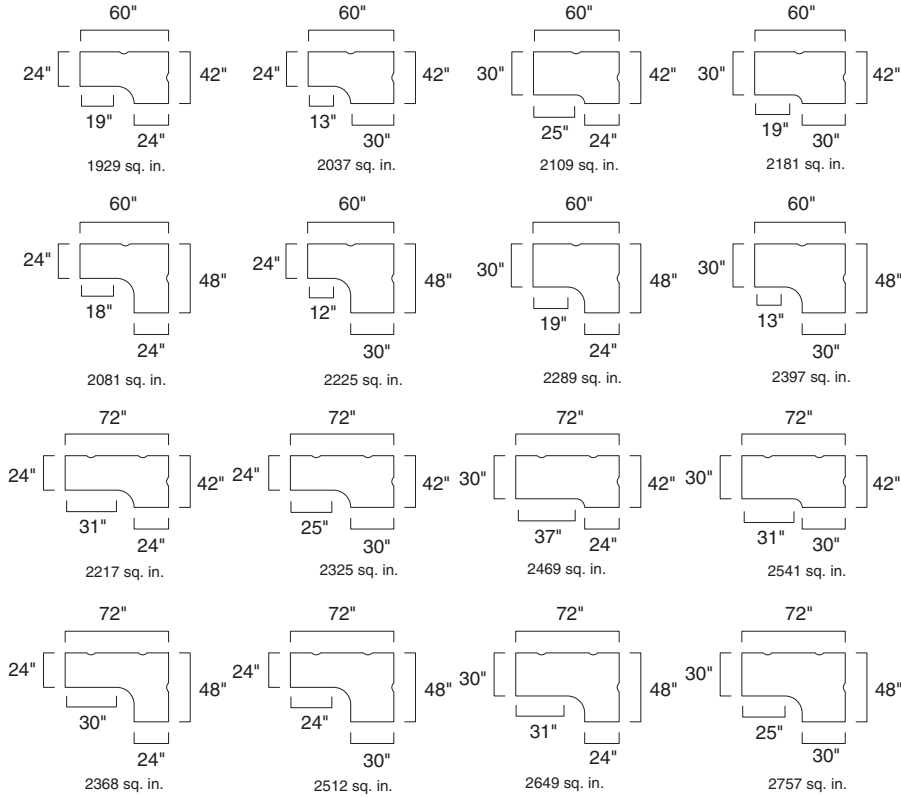

Statement of Line, continued



Understanding
 ▶ Page 208
 Specifying
 ▶ Page 529

Corner, 120° Worksurfaces

Corner, 120° Worksurfaces With 1/2" Cord Drop

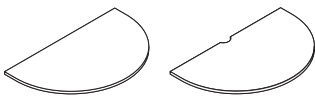
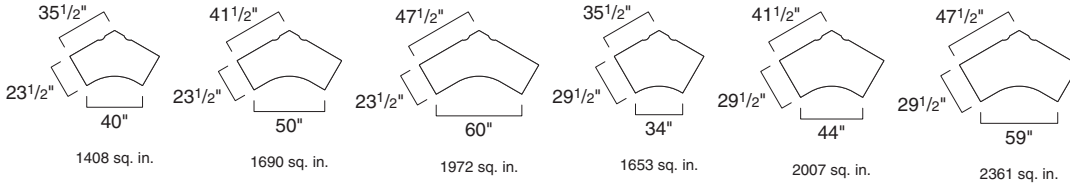

Understanding
 ▶ Page 208
 Specifying
 ▶ Page 530

Spanner Worksurfaces

For Use With 1/2" Cord Drop Worksurfaces

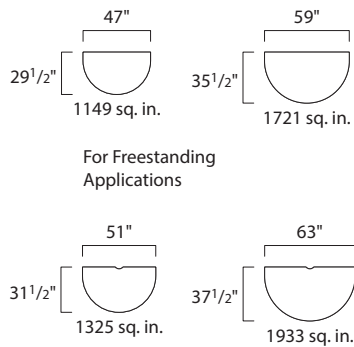

For Use With Full Depth Worksurfaces

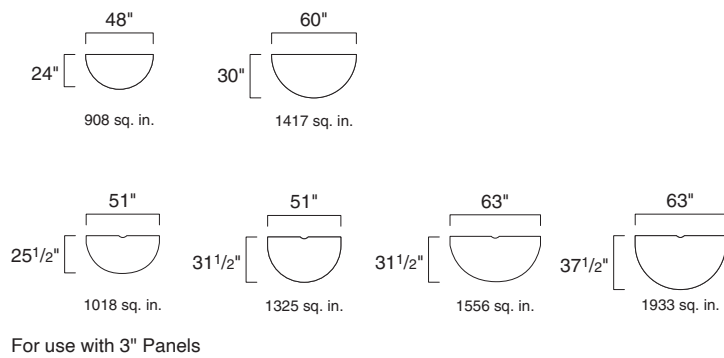

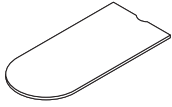

Understanding
 ▶ Page 208
 Specifying
 ▶ Page 532

Bullet Peninsula Worksurfaces

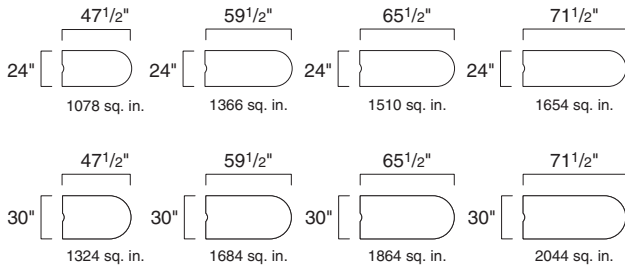

Tip: The same bullet peninsula work-surfaces can be used with either work-surfaces with 1/2" cord drop, or with full-depth worksurfaces.

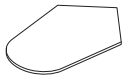

Understanding
 ▶ Page 208
 Specifying
 ▶ Page 533

Angled Peninsula Worksurfaces

With 1/2" Cord Drop

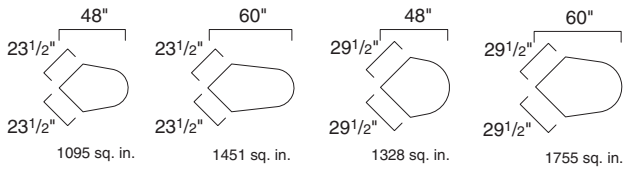

With Full Depth

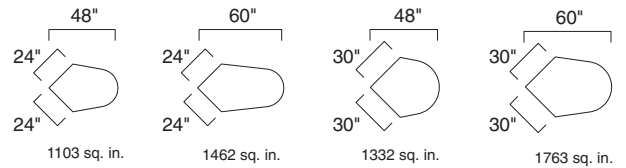

Understanding
 ▶ Page 208
 Specifying
 ▶ Page 534

Linking Peninsula Worksurfaces

With 1/2" Cord Drop

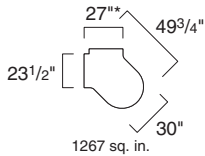

*Dimension includes notch width.

Statement of Line, continued



Understanding
 ▶ Page 208
 Specifying
 ▶ Page 536

Jetty Worksurfaces*

With 1/2" Cord Drop

*Left-hand units shown.
 Right-hand units available.

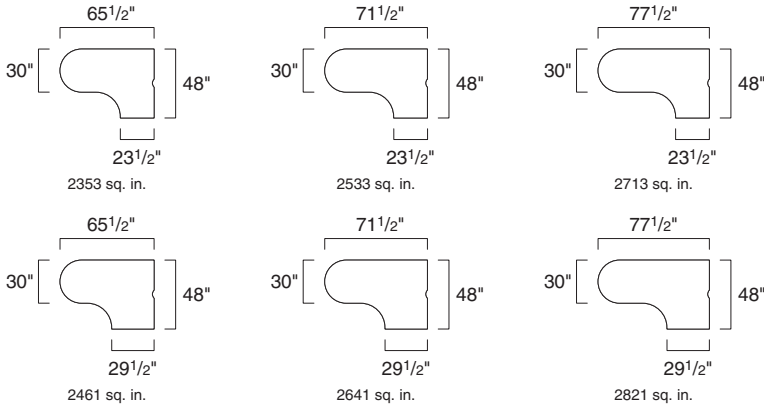

With Full Depth

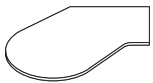
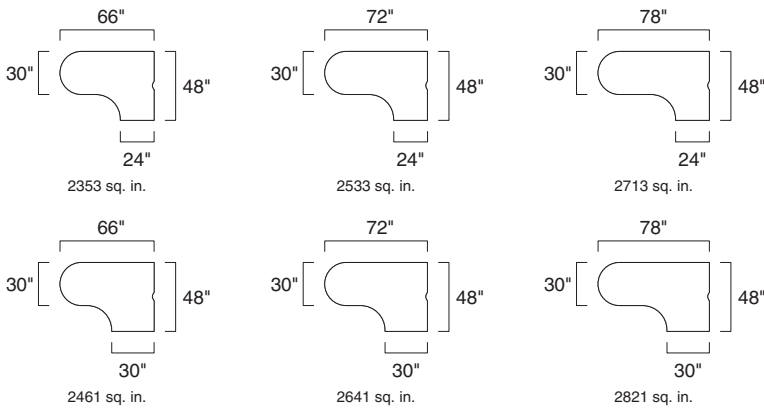

Understanding
 ▶ Page 208
 Specifying
 ▶ Page 538

Bubble Jetty Worksurfaces*

With 1/2" Cord Drop

*Left-hand units shown.
 Right-hand units available.

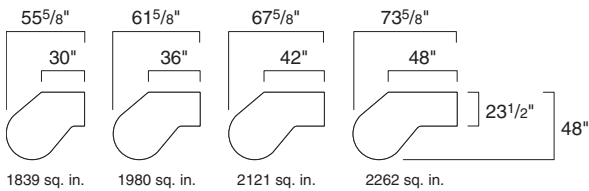

Understanding
 ▶ Page 208
 Specifying
 ▶ Page 540



Visitor Worksurfaces*

With 1/2" Cord Drop

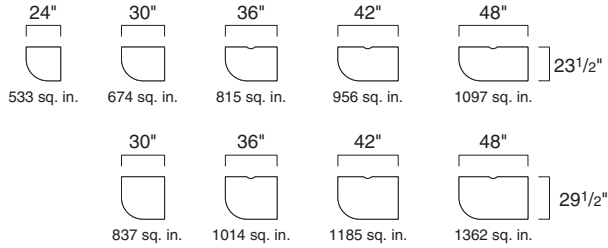

With Full Depth

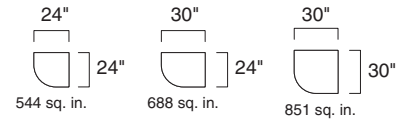

*Left-hand units shown. Right-hand units available.

Tip: 24"W and 30"W visitor worksurfaces are not available with cable scallops.



Understanding
 ▶ Page 208
 Specifying
 ▶ Page 540

Linking Worksurfaces*

With 1/2" Cord Drop



*Dimension includes notch width.

With Full Depth

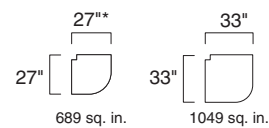

Understanding
 ▶ Page 220
 Specifying
 ▶ Page 544

Transaction Worksurfaces—Thin

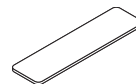
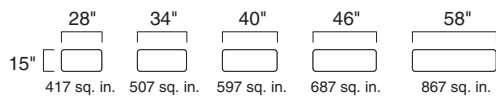

Understanding
 ▶ Page 220
 Specifying
 ▶ Page 544

Transaction Worksurfaces—Square and Oval

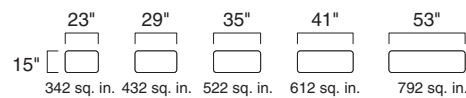

Worksurface Positioning

Universal Worksurfaces

Universal Worksurfaces is a comprehensive solution of worksurfaces, supports, and privacy screens designed to deliver flexibility, mobility, and options to create inspiring spaces that support the different ways people work. A beautiful, light-scale aesthetic which gives designers new solutions across a broad spectrum of applications including the following: traditional panel-mounted systems, freestanding light-scale desking, panel wrapped desking, private office, conference, and teaming. Consists of Universal Systems Worksurfaces, U-Free Desks and Universal Tables.

Universal Systems Worksurfaces

Main worksurface solution for the four primary space division products: Answer, Montage, and Kick. Worksurfaces can be panel-mounted or freestanding.

- Extensive shape and size offering allows designers to meet a variety of planning applications.
- Worksurfaces feature a choice of curvilinear or straight-front shapes.
- User front edge available in 3 mm edge.
- Available with 1/2" cord drop in the back of the worksurface providing the most efficient routing of cords and an uncluttered desktop.
- Also available full depth, providing an uninterrupted working surface that fits flush to the panel and allows L-configuration planning.
- Standard scallops allow large cord heads to easily pass below the desktop. Scallops can be eliminated for freestanding applications.
- Available with full offering of Steelcase High-Pressure Laminates or veneers; specifiable 3 mm edge colors.
- Worksurfaces can be supported with cantilevers, center support panels, end panels, pedestals, legs, or desk supports.
- Straight worksurface available to specify parametrically from 18"D to 36"D and from 18"W to 120"W in 1/16" increments.

Answer Freestanding Desks

Main desk solution for use with the four primary space division products: Answer, Montage, and Kick. Desks are built up from Universal components ordered separately and assembled onsite.

- Flexible product offering allows a wide range of desk applications for private offices, reception areas, and open plan settings.
- Non-handed desk components are easy to assemble and easy to reconfigure.
- Compatible with a wide range of worksurface products, including Universal Systems Worksurfaces, and many others.
- Wide range of storage available, including universal pedestals, lateral files, and hutches.
- Full-height and half-height modesty panels available for desks and peninsulas.
- Visually compatible with Universal tables, towers, and other products.

Universal Tables

Versatile freestanding tables appropriate for teaming and conferencing environments or for individual work areas. Tables can be fixed or mobile for increased flexibility or ease of reconfiguration.

- High-Pressure Laminate tables are available with a 3 mm edge. Wood veneer tables are available with a square (3 mm) edge.
- User edge on all sides of the tables and rounded corners allow a user to work on any side.
- Wide range of sizes and shapes available, from small personal tables to large conference tables.
- Available with full offering of Steelcase High-Pressure Laminates or veneers; specifiable 3 mm edge colors.
- T and X bases, post legs, C-leg, and adjustable-height legs give designers many functional and aesthetic options.

Elective Elements Worksurfaces

(See *Elective Elements Specification Guide*.)

Main worksurface solution for three primary space division products: Answer and Montage. Worksurfaces can be panel-mounted or built up into casegood solutions appropriate for private office solutions when combined with storage, end panels, and modesty panels.

- Extensive shape and size offering allows designers to meet a variety of planning applications.
- Worksurfaces feature a choice of curvilinear or straight-front shapes.
- Desk, bridge, return, peninsula, and desk return worksurfaces are also available for freestanding casegood applications in addition to the typical systems worksurface shapes.
- User-front edge is available in a choice of 3 mm plastic edges, wood edge profiles on laminate worksurfaces (square 5 mm), or wood edge profiles on wood worksurfaces (3 mm square, waterfall, or knife).
- Worksurfaces are depths 24" or 30".
- Scallops are optional, as well as round or square grommets, depending on power and cable management needs. Grommets are available, depending on the worksurface shape, typically in left, center, and right locations.
- Grommets must be used for worksurface cable or cord management to route cords below the desk top.
- Scallops are used for task light cord management only.
- Available with full offering of Steelcase laminates or veneers. Also available with Customiz stain or open line laminates.
- Worksurfaces can be supported with Elective Elements supports (center support panels, end panels, under-worksurface storage, or freestanding legs) as well as Universal cantilevers and side support brackets.
- Height adjustability is achievable by using the height-adjustable storage and/or legs. Range of maintenance adjustability is 29"H-32"H in 1/2" increments.

Panel-Mounted Worksurface Supports Integration Matrix

This matrix shows recommended panel-mounted supports for specific panel and worksurface combinations.

Refer to the appropriate Solutions Specification Guide (Answer or Montage) for detailed information.

	Answer Panel		Montage Panel		Kick Panel		V.I.A. Wall		Privacy Wall	
	Universal Systems Worksurfaces — with 1/2" Cord Drop	Universal Systems Worksurfaces — Full Depth	Universal Systems Worksurfaces — with 1/2" Cord Drop	Universal Systems Worksurfaces — Full Depth	Universal Systems Worksurfaces — with 1/2" Cord Drop	Universal Systems Worksurfaces — Full Depth	Universal Systems Worksurfaces — with 1/2" Cord Drop	Universal Systems Worksurfaces — Full Depth	Universal Systems Worksurfaces — with 1/2" Cord Drop	Universal Systems Worksurfaces — Full Depth
Universal Systems on-module supports, U style numbers Example: UCANT ▶ Page 552	●	●							●	●
Universal Systems supports for Montage panels, Z style numbers Example: ZUCANT ▶ See <i>Montage Solutions Specification Guide</i> .			●	●						
Universal Systems supports for V.I.A. walls, V style numbers Example: VUCANT ▶ See <i>V.I.A. Specification Guide</i> .							●	●		

Legend

- = Recommended solution
- Tip: Alignment tabs will need to be knocked down when full-depth worksurfaces are used.*

Worksurface Support Guidelines

Worksurface spans greater than 54" require a brace or additional support to the floor. Spans greater than 72" wide cannot be supported only by a reinforcing channel, and require additional supports to the floor. Calculate span distance by measuring from edge of one end of worksurface to edge of other end of worksurface.

Exception: When using pedestals or lateral files to support a worksurface, measure from the inside edge of the storage unit.

Worksurfaces can span up to 60" in heavy load applications and up to 72" in light load applications if a reinforcing channel is used. A light load application is less than 40 pounds placed on a worksurface. Reinforcing channel must be specified separately.

▶ Page 553

Exception: Knife edge worksurfaces require support on spans greater than 48"W.

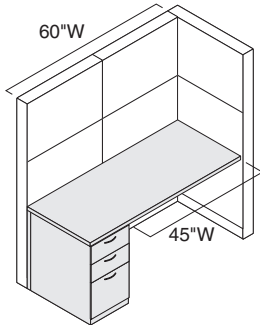

Reinforcing channel is not required on worksurfaces with spans less than 54"W.

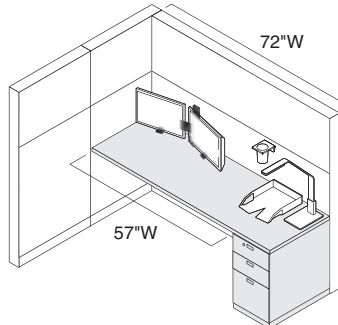

Lightly loaded applications typically include a workstation with monitors, lighting, limited organizational tools, and personal items.

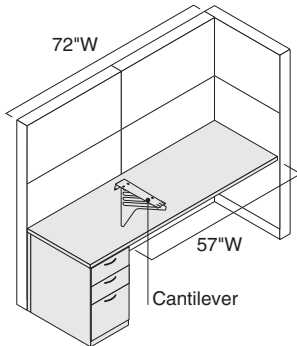

Reinforcing channel or additional support is required for worksurfaces with spans greater than 54"W and less than 72"W in light use applications and on worksurfaces with spans greater than 54"W and less than 60"W in heavy load applications.

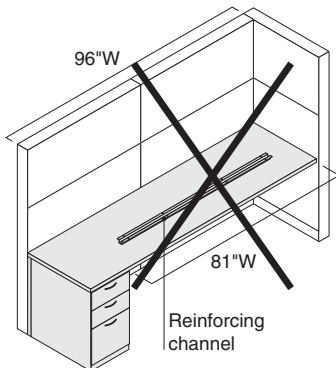

Worksurface span cannot be supported solely by a reinforcing channel. Additional to the floor supports are required.

Tip: Reinforcing channels add 1"D below the worksurface.

Tip: For maximum effectiveness, place the reinforcing channel in the middle of the worksurface span.

Calculate span distance by measuring from edge of one end of worksurface to edge of other end of worksurface. To determine size of reinforcing channel needed, deduct the amount listed in the matrix below from the measured span. Deduction in inches is based on combination of the left-hand and right-hand supports.

Example: 72"W measured span, with application of cantilever for left-hand support and end panel for right-hand support, has a span deduction of 6" for a reinforcing channel size of 66" (72"-6" = 66"). For this application, use reinforcing channel TS7WKSPT66.

Worksurface Span Deductions for Determining Reinforcing Channel Size		Right-Hand Support						
		End Panel	FrameOne Leg	FrameOne Leg-Table Application	Intermediate Support	DBL Post Leg	Cantilever	All other Legs/Supports
Left-Hand Support	End Panel	-6"	-6"	-9"	-9"	-6"	-6"	-6"
	FrameOne Leg	-6"	-6"	-9"	-9"	-6"	-6"	-6"
	FrameOne Leg-Table Application	-9"	-9"	-12"	-12"	-9"	-9"	-9"
	Intermediate Support	-9"	-9"	-12"	-12"	-9"	-9"	-9"
	DBL Post Leg	-6"	-6"	-9"	-9"	-6"	-6"	-6"
	Cantilever	-6"	-6"	-9"	-9"	-6"	-6"	-6"
	All other Legs/Supports	-6"	-6"	-9"	-9"	-6"	-6"	-6"

Reinforcing Channel Sizes		
Style Number	Nominal	Actual
TS7WKSPT39	39"W	39.231"W
TS7WKSPT48	48"W	47.547"W
TS7WKSPT51	51"W	50.547"W
TS7WKSPT54	54"W	53.547"W
TS7WKSPT	57"W	56.547"W
TS7WKSPT60	60"W	59.547"W
TS7WKSPT63	63"W	62.547"W
TS7WKSPT66	66"W	65.547"W
TS7WKSPT72	72"W	71.547"W

Note: If the deducted span distance falls between two reinforcing channel sizes, select the smaller of the two sizes.

Reinforcing Channel Size for Straight 120° Worksurfaces

To calculate the reinforcing channel size for a straight 120° worksurface, use the user edge length, subtract 6", and order the next shortest channel. See chart below.

Back Edge Width	Worksurface Depth	User Edge Depth	Reinforcing Channel Size
48"	23½"	61⅛"	54"W
48"	29½"	65⅛"	57"W
60"	23½"	73⅞"	66"W
60"	29½"	77⅞"	66"W
72"	23 ½"	85⅞"	72"W
72"	29½"	89⅞"	72"W

Support Requirements for Peninsula Worksurfaces

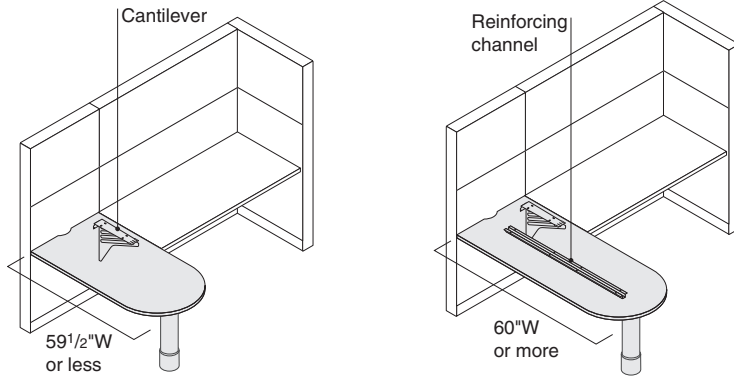

Peninsula worksurfaces smaller than 60"W do not require a reinforcing channel. Location of leg or column support, determined by pilot holes, meets the requirements for worksurface support every 54". Sizes 60"W or greater require a reinforcing channel. Determining brace size for peninsula worksurfaces: If worksurface is supported by a single column or legs, subtract 21" from span of worksurface to determine reinforcing channel size. Example: 72"W measured span has a span deduction of 21" for a reinforcing channel size of 51" ($72" - 21" = 51"$). For this application, use reinforcing channel TS7WKSPT51.

Universal Worksurface Thought Starters

Universal Worksurface Products provide a variety of traditional and non-traditional methods of applying worksurfaces and supports. Worksurfaces can be supported in on-module and off-module panel-supported applications, freestanding configurations, and many combinations of these applications. The thought starters included on the following pages can help leverage the benefits of the worksurfaces in new and unique ways.

Universal Worksurface Products provide significant planning flexibility:

- Systems Worksurfaces and Tables can be used together, and a wide range of worksurface shapes and sizes allow various footprints to be achieved.
- Systems Worksurfaces can be used with Answer and Kick panels, Montage frames, and V.I.A. walls. They can be panel-supported or freestanding. *Tip: Corner 120° Systems Worksurfaces may not be panel-supported with Montage panels due to the unique design of the Montage 120° junction.*
- Freestanding, mobile worksurfaces and tables allow user control of the workspace to provide either privacy or team collaboration.
- 26"H and 28½"H legs may be installed 3", 6", or 9" from the edge of most Tables to accommodate nesting and slip-fit capability.
- Adjustable-height legs are available on Systems Worksurfaces and Tables. Legs adjust 25½"H to 31½"H in ¾" increments.

Freestanding tables with legs installed 6" or 9" from the edge allow the worksurface to slip-fit over the panel-mounted Systems Worksurface. This configuration also allows the user to face the aisle while working at the computer.

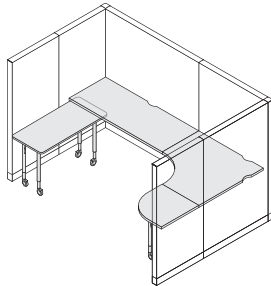

Full depth systems worksurfaces allow L-configurations without uneven gaps. This configuration uses an angled peninsula worksurface to provide an aisle-facing place for active work and meetings. A 96" long straight worksurface creates a large, unbroken area to spread out work in progress. All the worksurfaces in this configuration are symmetrical, making it easy to plan mirror image applications.

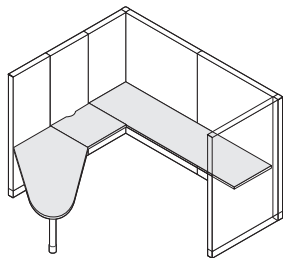

U-Configuration with Large Footprint

Recommended Worksurfaces

One 24"D x 72"W straight table	BFS2472
One 23½"D x 60"W straight worksurface	US2460
One 23½"D x 23½"D x 41½"W x 41½"W corner, curved-front worksurface	UCC224242
One 23½"D x 30"W visitor, curved-front worksurface	UVC2430R

L-Configuration with Large Footprint

Recommended Worksurfaces

One 24"D x 24"D x 60"L angled peninsula worksurface	WPA2460
One 24"D x 24"W straight worksurface	WS2424
One 24"D x 96"W straight worksurface	WS2496

Universal Worksurface Thought Starters, continued

Systems worksurfaces with 1/2" cord drop allow easy cord management with uniform gaps whenever corner worksurfaces are used. This U-configuration uses 18³/₈"D worksurfaces to create a spacious workstation in a 6x7 footprint.

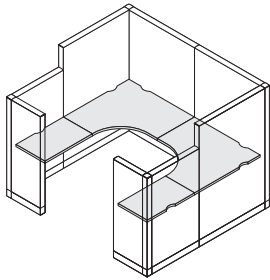

U-Configuration with Medium Footprint

Recommended Worksurfaces

Two 18 ³ / ₈ "D x 30"W straight worksurfaces	US1830
Two 18 ³ / ₈ "D x 18 ³ / ₈ "D x 41 ¹ / ₂ "W x 41 ¹ / ₂ "W corner, curved-front worksurfaces	UCC114242

Tapered worksurface shapes can maximize space for the user by providing extra depth for the computer only where it's needed. This configuration uses a taper-flat worksurface and an 18⁷/₈"D return to give the user more space in a 6x6 footprint. The user can also face toward the aisle while working at the computer.

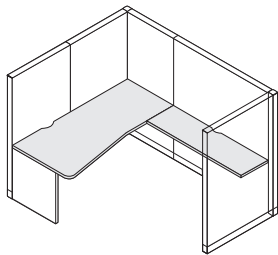

L-Configuration with Small Footprint A

Recommended Worksurfaces

One 30"D x 24"D x 72"W taper-flat worksurface	WTTF3272
One 18 ⁷ / ₈ "D x 48"W straight worksurface	WS1848

Freestanding tables with nesting-height legs

allow tables to nest under panel-mounted Systems Worksurfaces. This configuration uses an 18"D Systems Worksurface and allows a small workstation to expand and decrease, giving users control over their space.

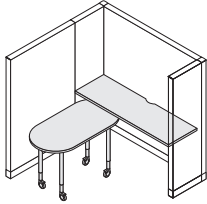

L-Configuration with Small Footprint B

Recommended Worksurfaces

One 24"D x 48"W capsule table	BFK2448
One 18 ³ / ₈ "D x 60"W straight worksurface	US1860

Spacious U-configurations with a minimum number of panels and work-surfaces

can be created with 60"W x 60"W corner, curved-front and linking peninsula Systems Worksurfaces.

Penta Cube

Recommended Worksurfaces

Six 24"D x 60"W x 60"W x 24"D corner, curved-front worksurfaces (3 mm edge)	UCC226060
Five linking peninsula worksurfaces (3 mm edge)	UPAC2748
One straight worksurface (3 mm edge)	US2460

Tip: Size of linking peninsula worksurface to be used is determined by the panel system which it will be used with. Answer panels are shown at left.

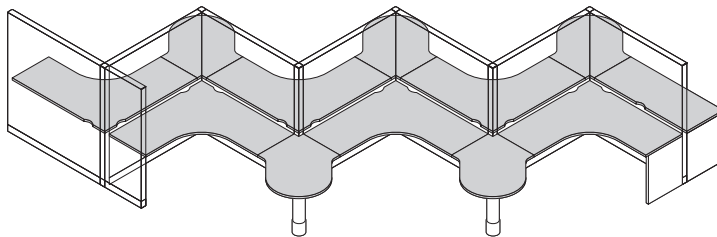

Universal Systems Worksurfaces

Systems worksurfaces— with 1/2" Cord Drop feature built-in cable management flexibility, allowing cords to drop below the worksurface at any point along the back edge.
▶ Specifying page 500

Systems worksurfaces— Full Depth feature a tighter fit to panels for a cleaner aesthetic.

Systems straight work-surfaces with 1/2" cord drop and full depth are available in a variety of widths and depths in modular and parametric dimensions.

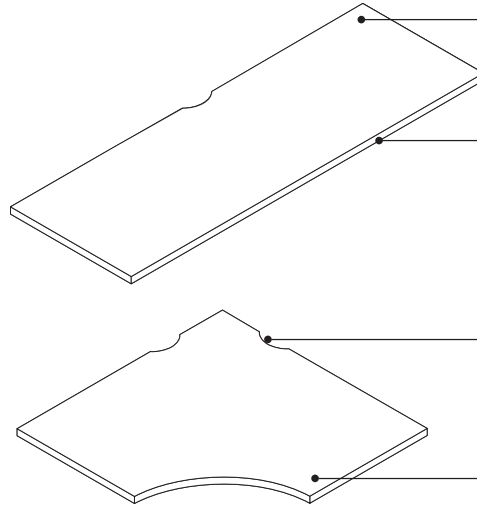

Full-depth worksurfaces fit flush against panels. Cords and cables are routed through cable scallops.

Front (user's) edge is available in three edge profiles on laminate worksurfaces. Wood veneer work-surfaces have a square (3 mm) edge profile only. Back and side edges are flat.

Cable scallops allow cords and plugs to pass behind the worksurface. Cable scallops can be omitted as an option.

Worksurface has a wood core with a High-Pressure Laminate or wood veneer surface and is 13/16" thick.

Product Details

High-Pressure Laminate Worksurfaces

Front (user's) edge profile is available in two shapes.

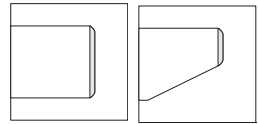

3 mm edge profile Knife edge profile

PVC-free, 3 mm edge profiles are proprietary polyolefin blend for all solid colors and seven woodgrain finishes. Matching 1 mm side and back edges are also PVC-free.

▶ See surface material listing in this book for specific PVC-free availability.

Knife edge with 3 mm user edge is available on straight systems worksurfaces and on round tables.

Edge profile finishes are specified separately from laminate color.

Wood Veneer Worksurfaces

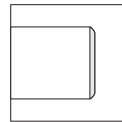

Front (user's) edge profile is wood veneer with a square (3 mm) radius. Back edge and edge that joins to adjacent worksurfaces are flat. Wood edge color matches finish specified for worksurface.

Edge Profiles

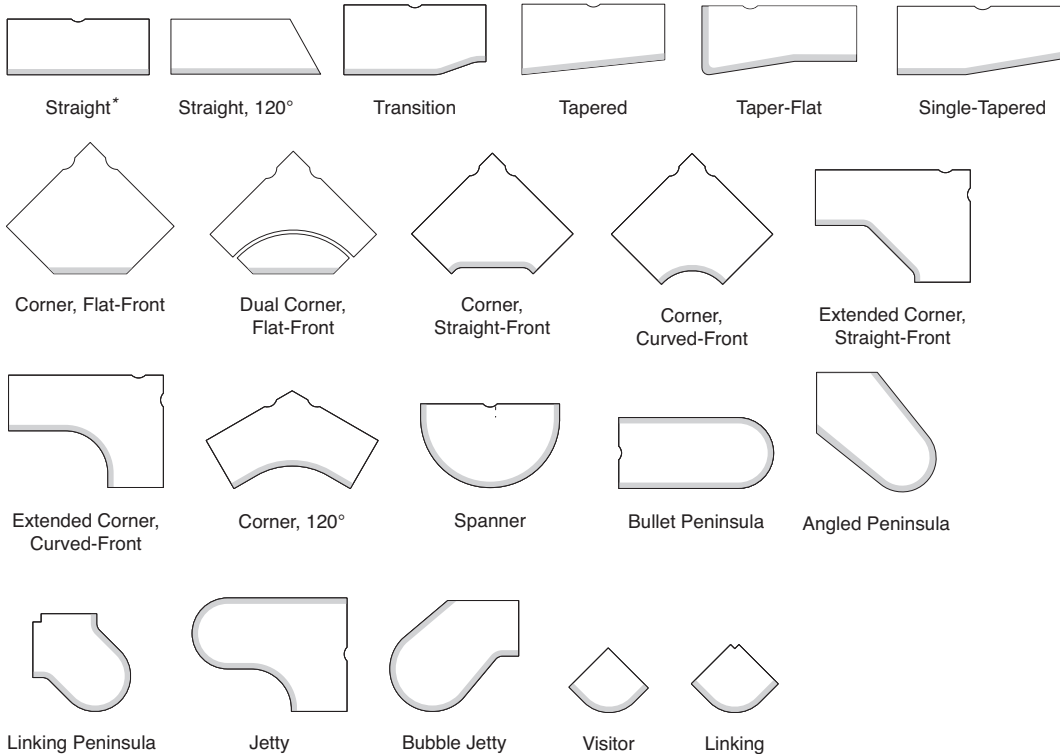

Edge profile is applied to front (user's) edge only.

*Tip: Straight worksurface width is available parametric from 18"W–120"W in 1/16" increments. Straight worksurface depth can be specified parametric from 18"D–36"D in 1/16" increments.

Universal worksurfaces are undersized about 0.05 inches from ordered dimension to ensure fit in panel wrapped applications.

Straight worksurfaces are available to specify parametrically. The parametric dimensions available are from 18" to 36" deep and from 18" to 120" wide in 1/16" increments both depth and width.

Parametric straight worksurfaces are available in laminate with a 3 mm plastic edge, knife edge, or soft edge options and wood veneer with square edge or soft edge options.

Parametric straight worksurfaces have the option to specify a scallop, grommet cutouts, power and data access door and tray cutout, or power access door.

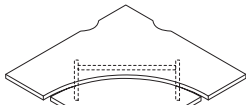

Dual-worksurfaces are two pieces - a large monitor surface with a smaller keyboard surface attached. A dual-arm spring mechanism provides superior stability when compared to the single-arm spring mechanism used in worksurfaces with an adjustable keyboard shelf.

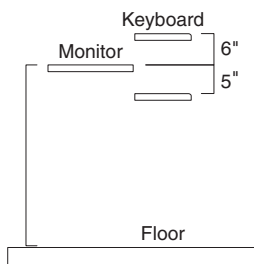

Keyboard surface on dual worksurface can be adjusted to positions up to 6" higher or 5" lower than the monitor worksurface.

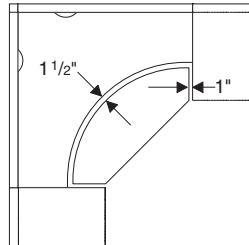
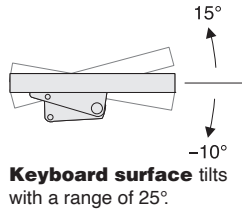

A 1" gap separates the sides of the keyboard surface and adjacent worksurfaces. There is also a 1 1/2" space between the keyboard and monitor surfaces.

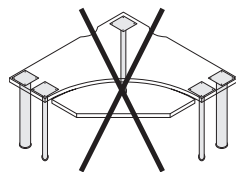

Dual worksurfaces cannot be used as a single worksurface. Dual worksurfaces must be tethered to a panel or connected to an adjacent worksurface in a freestanding application.

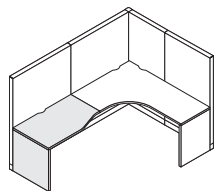

30°D straight, tapered, and transition cantilevered worksurfaces require additional floor support along the front edge, such as a pedestal, end panel, post leg, side support bracket, or an adjacent return worksurface.

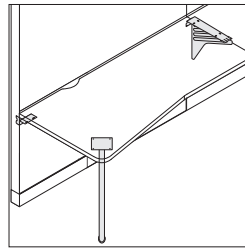
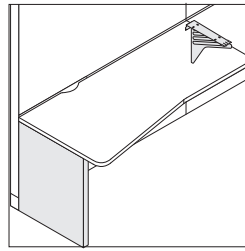

Taper-flat worksurfaces can be supported at the larger end with a side support bracket and a post leg. If the larger end is 30"D, a 24"D end panel can also be used.

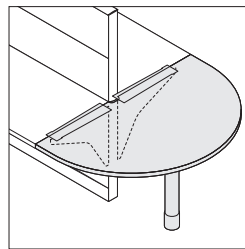

Spanner worksurfaces with 3" notch accommodate Answer panels. Legs and cantilevers or column and cantilevers must be used for support.

Notch is not included on spanner worksurfaces for freestanding applications without panels.

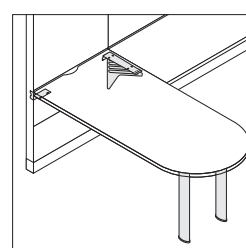
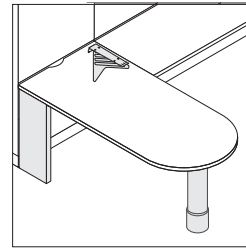

3 mm edge bullet peninsular, jetty, and bubble jetty worksurfaces can be supported two ways:

- With a cantilever, a center support panel and a column
- With a cantilever, a side support bracket, and two post legs

In certain applications, a center support panel should not be used because the unfinished top edge of the support panel would be exposed. Use a cantilever, a side support bracket, and two post legs instead. These applications include:

- Angled peninsula with 3 mm edge and 1/2" cord drop

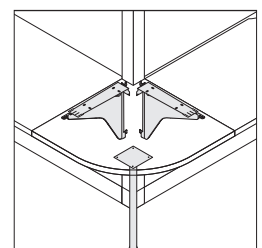
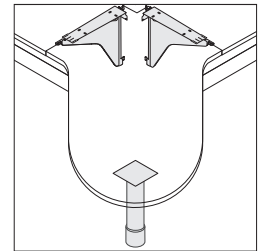

Linking peninsula worksurfaces and linking worksurfaces with 3" notch accommodate Answer panels. Legs and cantilevers or column and cantilevers must be used to support linking peninsula worksurfaces. One leg and two cantilevers must be used to support linking worksurfaces.

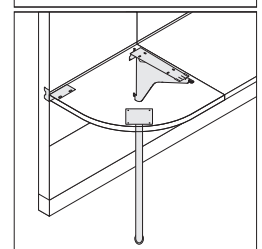
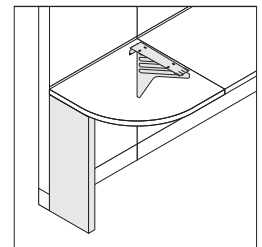

3 mm edge visitor worksurfaces must be supported by either a cantilever and a center support panel, or by a cantilever, a side support bracket, and a leg.

Universal Systems Worksurfaces, continued

Connections

Worksurfaces can be used freestanding or in panel-supported installations.

Supports are ordered separately and installed in the field.

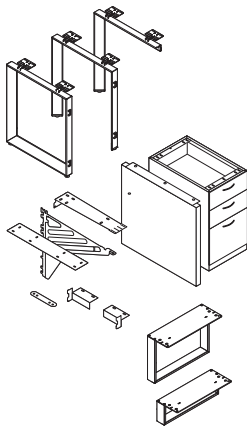

For panel-supported applications you can use:

- Closed loop
- Open loop
- Half loop
- Intermediate support
- Off-module worksurface-to-panel connector
- Side support brackets
- Cantilever with tie plate
- End panel
- Standing-height end panel
- Support plate
- Center support panel with tie plate
- Standing-height center support panel with tie plate
- Columns or legs

▶ See page 222 for *Panel-Mounted Universal Systems Worksurface Supports*.

- Universal pedestal with filler
- Universal lateral file with underworksurface lateral file filler

▶ See *Storage Specification Guide*.

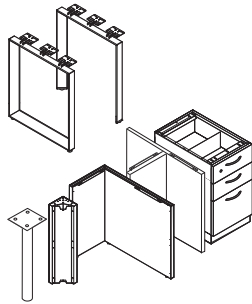

For Answer Freestanding desk applications you can use:

- End supports
 - Peninsula supports
 - Corner support
 - Columns and legs
 - Closed loop or open loop
 - Modesty panels
 - Pedestals
 - Lateral files and storage cabinets
- ▶ See *Answer Freestanding Specification Guide*.

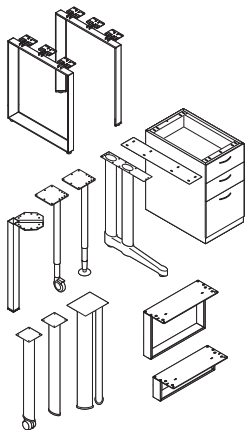

For leg-based applications you can use:

- Closed loop
- Open loop
- Intermediate support
- Post legs
- Double post leg
- Double post C-leg
- Support plate

▶ See page 230 for *Legs and Columns for Universal Systems Worksurfaces*.
Tip: Pedestal can also be used in leg-based freestanding installations.

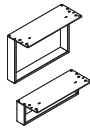

Intermediate supports replace the need for other types of worksurface support when used with 1-High or 1.5-High Universal storage.

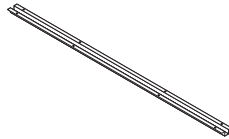

Worksurface spans greater than 54" require additional support of a cantilever, pedestal, intermediate support, or leg. Exception: Worksurfaces can span up to 60" in heavy load applications and up to 72" in light load applications if a TS7WKSPT reinforcing channel is used. Reinforcing channel must be specified separately.
 ▶ Page 553

Knife edge worksurfaces require reinforcement channels for spans greater than 48". Use TS7WKSPT39 for 54"W worksurfaces, TS7WKSPT for 60"W and 66"W worksurfaces, and TS7WKSPT72 for 72" worksurfaces.

Heavy load worksurfaces spanning greater than 60", or all worksurface spans wider than 72" require additional support of a cantilever, pedestal, intermediate support, or leg.

Wiring & Cabling

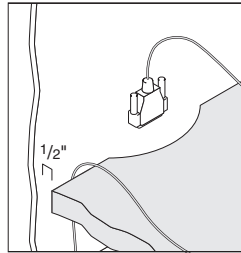

Worksurface depth is 1/2" less than nominal and allows cords and cables to pass over at any point. Cable scallops provide space for plugs to pass over the back edge of the worksurface.

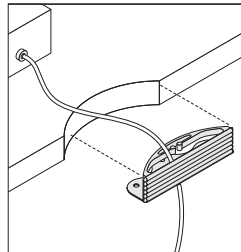

Cable scallop allows cord plugs to easily pass below the worksurface. Worksurface wire managers are available to convert cable scallops into grommets in freestanding applications. Wire managers are included with wood veneer worksurfaces. Wire managers for use with laminate worksurface must be ordered separately.

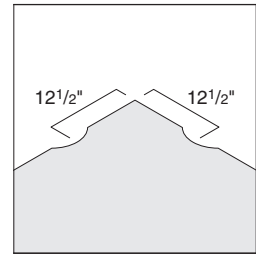

Corner worksurfaces have scallops located 12 1/2" from the rear corner of the worksurface to the center of the scallop. Taper-flat worksurfaces have a single scallop located 18 1/2" from the larger end. Scallops are centered on the rear edge of all other worksurfaces that include them.

Cable scallop can be omitted for freestanding applications or panel-supported applications where plugs do not need to pass over the back edge of the worksurface.

Cable management devices are available to help manage conventional and fiber-optic cables beneath the worksurface.
 ▶ See *Worksurface Power and Communication*, page 573.

Parametric straight worksurfaces have two grommet cutout options. The 2" round grommet cutout option fits the AWAG2 grommet which is specified separately.
 ▶ See page 575

The 3" round grommet cutout option fits the TSAEGROM grommet which is specified separately.
 ▶ See page 576

The grommet cutout option is not available on a worksurface when the power access door option is selected.

Grommet cutouts in parametric straight work-surfaces can be specified in the center, the left, or the right sides of the worksurface. Grommet cutouts are available in the below configurations.

Grommet Location on Worksurface	Minimum Worksurface Widths
Center, Right, or Left	All widths
Right and Left	At least 25"W
Right and Center	At least 34"W
Left and Center	At least 34"W
Center, Right, and Left	At least 34"W

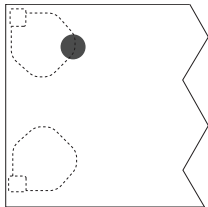

FrameOne post legs will interfere with the left or right grommet cutouts on parametric Universal straight work-surfaces.

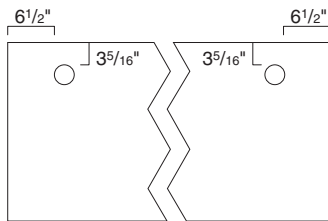

Grommet cutouts in parametric straight work-surfaces are located 3⁵/₁₆" from the back edge of the worksurface to the back edge of the grommet cutout. Left and right grommet cutouts are located 6¹/₂" from the edge of the worksurface to the outside edge of the grommet cutout.

Surface Materials

High-Pressure Laminate Worksurfaces

- Laminate
- ▶ See *Surface Materials Reference Manual*.
- Open Line laminate (option) A program including non-Steelcase laminates which are suitable for use on Steelcase products.
- ▶ See *Surface Materials Reference Manual*.

Front (user's) edge(s)

- Plastic

Back and side edges

- Plastic color default to match user's edge

Wood Veneer Worksurfaces

- Wood veneer (standard)
- Customiz stain (option)
- Full-fill finish (option)

Square (3 mm) edge profile

- Wood veneer to match worksurface

Front (user's) edge(s)

- Wood edge band

Application Topics

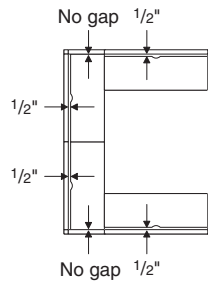
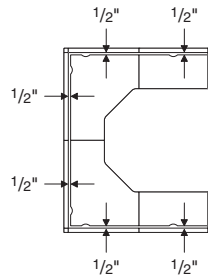

Full-depth worksurfaces provide an uninterrupted working surface and are designed to allow traditional corner or L-configuration planning without creating uneven gaps.

Plan using worksurfaces actual dimensions when panel-wrapping worksurfaces because worksurface depths and widths vary by type. Straight and transition worksurfaces are full-width to correspond directly with panel width. Corner, extended corner, 120° corner, bullet peninsula, jetty, visitor, and linking worksurfaces are 1/2" less than panel width to allow for a consistent 1/2" cable-management gap when used in combination with straight worksurfaces.

Tip: To avoid uneven gaps in panel-supported applications, use full-depth worksurfaces to create L-configurations.

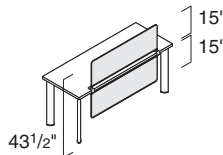

Screens mount to worksurfaces in privacy position or below the worksurface for modesty.

- ▶ See *Screens*, page 561.

Worksurfaces used in panel-supported installations must follow applicable panel stability guidelines.

- ▶ Page 140

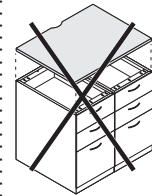

Do not use a Universal Systems Worksurface

as a top for storage that matches the worksurface width. Universal Systems Worksurfaces are slightly undersized for panel-wrapped applications and will not fit over full-width storage. Use field-installed storage tops for this type of application.

- ▶ See *Storage Specification Guide*.

Knife edge worksurfaces

have limitations for support options and application restrictions.

- ▶ See page 232 for *Knife Edge Worksurface Application Guidelines*

Shipping

Palletizing streamlines unloading and staging of worksurfaces. Identical worksurfaces ordered on the same line item are packed on pallets containing 5–50 worksurfaces depending on worksurface size. Remaining worksurfaces are packed individually in cartons. If palletizing is not desired, order in quantities of four or less per line item. For maximum unload efficiency, utilize pallet handling equipment at job site whenever possible. Wood veneer worksurfaces cannot be palletized.

Universal Systems Worksurfaces with Soft Edge, Power and Data Access Door and Tray

Soft edge provides a comfortable user experience reducing strain on wrists and forearms.

► Specifying page 508

Power and data access door and tray provides desk top access and management of cords.

► Specifying page 546

Soft edge and power and data access door and tray cutout are available in modular and parametric straight worksurfaces, both 1/2" cord drop and full depth.

Cutout is optional; power and data access door and tray is ordered separately. 24"W cutout is centered near the back of the worksurface.

Edge is soft to the touch and flexes to conform to the arm.

Power and data access door and tray is available with cord or with modular or hardwire connection.

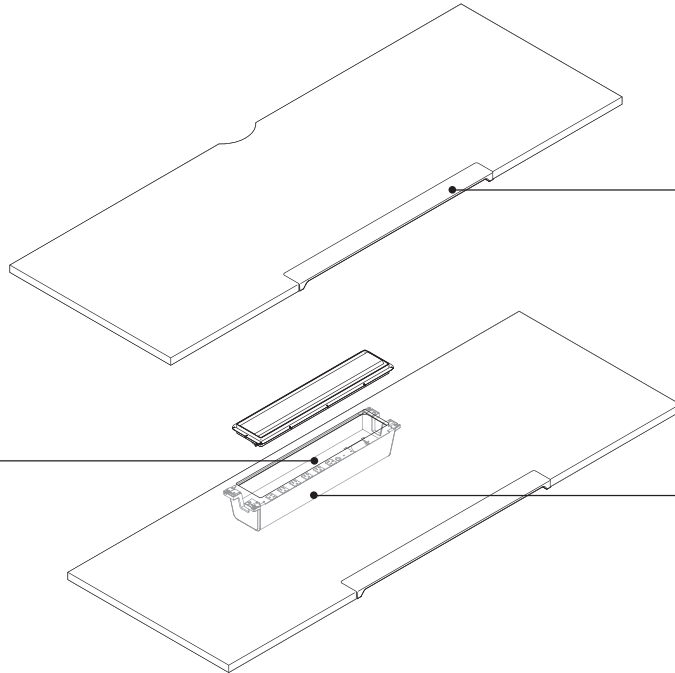

Soft edge is 36" wide centered on the worksurface; balance of front edge is 3 mm radius. Back and side edges are flat.

Soft edge and power and data access door and tray are available on straight and taper Universal Systems Worksurfaces with 1/2" cord drop and full depth.

Tray includes six simplex receptacles and cutout for data access.

Soft Edge, Power and Data Access Door and Tray Worksurface Availability

	48"W	54"W	60"W	65"W	72"W	78"W	84"W	90"W	96"W	102"W	108"W	114"W	120"W
Modular	48"W	54"W	60"W	65"W	72"W	78"W	84"W	90"W	96"W	102"W	108"W	114"W	120"W
Parametric	48"W- 53 ¹⁵ / ₁₆ "W	54"W- 59 ¹⁵ / ₁₆ "W	60"W- 64 ¹⁵ / ₁₆ "W	65"W- 71 ¹⁵ / ₁₆ "W	72"W- 77 ¹⁵ / ₁₆ "W	78"W- 83 ¹⁵ / ₁₆ "W	84"W- 89 ¹⁵ / ₁₆ "W	90"W- 95 ¹⁵ / ₁₆ "W	96"W- 101 ¹⁵ / ₁₆ "W	102"W - 107 ¹⁵ / ₁₆ "W	108"W- 113 ¹⁵ / ₁₆ "W	114"W- 119 ¹⁵ / ₁₆ "W	120"W

Modular Straights Parametric Straights

24", 30", and 36"D*	24"-36"D*	●	●	●	●	●	●	●	●	●	●	●	●
---------------------	-----------	---	---	---	---	---	---	---	---	---	---	---	---

Modular Tapered

29 1/2"D or 30"D to 23 1/2"D or 24"D	48"W	60"W	72"W
--------------------------------------	------	------	------

● Only soft edge, only power & data access door & tray, or both
*Tip: Subtract 1/2" for worksurfaces with cord drop.

Dimensions

	Soft edge	Cutout for Door	Tray (below worksurface)
Width	36"	24"	27 1/8"
Depth	3"	4 5/8"	6"
Thickness	1/2" at front	N.A.	N.A.
Height	N.A.	N.A.	4 3/4"

Product Details

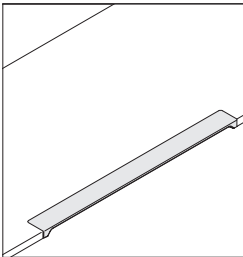

Soft edge profile is polyurethane and is available with Bactiblock™ antimicrobial protection.

High-Pressure Laminate Worksurfaces

PVC-free, 3 mm edge profiles are proprietary polyolefin blend for all solid colors and seven woodgrain finishes. Matching 1 mm side and back edges are also PVC-free. See surface material listing in this book for specific PVC-free availability.

3 mm front edge is specifiable. Back and side edges match 3 mm front edge.

Edge profile finish for 3 mm front edge is specified separately from laminate color.

Wood Veneer Worksurfaces

Front (user's) edge profile is wood veneer with a square (3 mm) radius. Back edge and edge that joins to adjacent worksurfaces are flat. Wood edge color matches finish specified for worksurface.

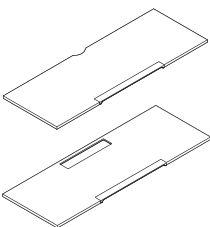

Scallops are omitted on worksurface when cutout for power and data access door and tray option is selected.

Power and data access door and tray cutouts are 3⁵/₁₆" from the back edge of the worksurface and always centered on the width of the worksurface.

Power and data access door and tray cutouts are available on worksurfaces 24"D through 36"D.

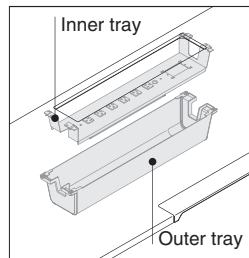

Inner tray provides under the surface power and data connections and access and cord management.

Outer tray provides cover and management for harness, cord, and/or data cables to and from the panel.

Power and data access door and tray flips toward the user.

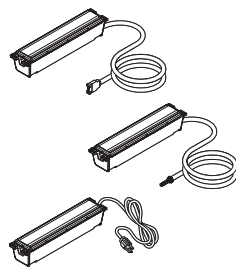

Modular, cord and plug, or hardware options are available.

Corded version includes 10' cord with plug. Modular and hardware versions each include 8' of harness.

Three wiring schematics are available in the modular version – 3+1, 2+2, and 3 separate neutrals (3SN). Each has a single circuit. 3+1 and 2+2 have the option for line 1, 2, 3, or 4 with either a system or isolated ground. 3SN has the option for line 1, 2, or 3 with either a system or isolated ground.

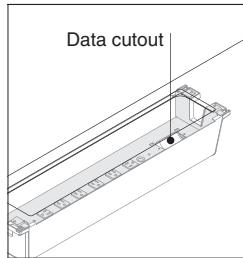

Data cutout in tray can accommodate either a single gang or a modular furniture communication faceplate. Tray includes adapter to accommodate modular faceplate.

Filler packages are available to fill unused data cutouts. Order separately in packages of 20.

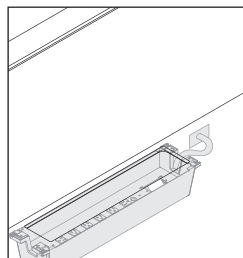

With the modular and hardware version, the harness enters the panel through a field cut opening in a fabric skin. A grommet is included to provide a finished edge to the field cut opening in the skin where the harness enters the panel. Inside the panel the harness can connect to a powerkit or it can use either a harness to harness connector or a branching harness to harness connector to connect to other modular harness trays or modular harnesses.

Cord and plug version has an integrated overload circuit breaker.

Non-PVC versions are available for each power solution.

Connections

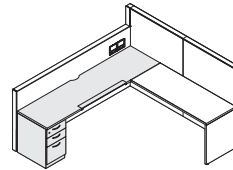

Fixed storage can be used with worksurfaces with soft edge but must not encroach the 36" width of the edge.

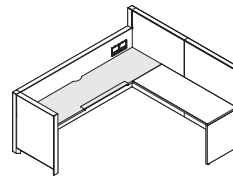

Worksurfaces connected perpendicular should not encroach the 36" width of the soft edge.

Soft edge worksurfaces are available with the same support options and follow the same application rules as other Universal Systems worksurfaces.

▶ See page 208 for Universal Systems Worksurfaces Understanding. *Exception: 48"W worksurface with soft edge used with the FrameOne post leg has some limitations.*

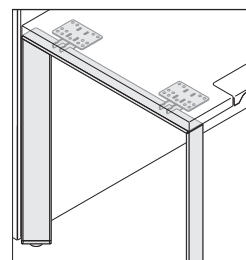

In an end-of-run condition, the FrameOne post leg will not fit when used with 48"W soft edge worksurfaces, use half, open, or closed loop legs.

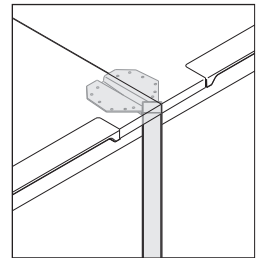

In shared applications, the FrameOne post leg can be angled and positioned at the front edge or for a square orientation it must be inset 1" from the front edge when used with 48"W soft edge worksurfaces.

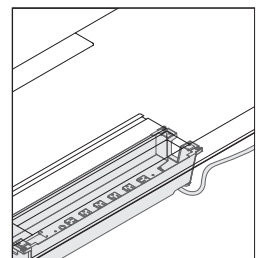

Access holes in tray allow power and data to be routed straight back when worksurface is against the panel or routed to the sides when the worksurface is perpendicular to the panel.

Worksurfaces with power and data access door and tray are available with the same support options and follow the same application rules as other Universal Systems worksurfaces.

▶ See page 208 for Universal Systems Worksurfaces Understanding.

Universal Systems Worksurfaces with Soft Edge, Power and Data Access Door and Tray, continued

Tray with cord and plug can be used in a freestanding table application.

Worksurfaces with power and data access door and tray with modular or hardwire power cannot be used in a freestanding application. The worksurface must either be attached to a panel on one end or if the worksurface is attached to low storage with an intermediate support on one end, the cabinet must be attached to the panel or ganged to another storage cabinet. This applies to both parallel or perpendicular to the panel applications.

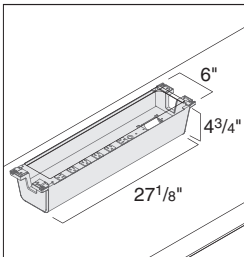

Height of tray is 4³/₄" so lower storage height must be accounted for when used adjacent to tray.

Width of outer tray below the worksurface is 27¹/₈" so adjacent lower storage dimensions must be accounted for on each worksurface width.

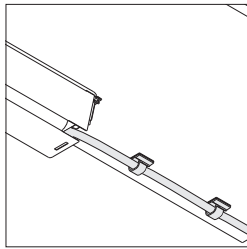

Tray with cord and plug includes two cord clips to help manage the cord below the worksurface.



Tray with modular harness or hardwire harness includes two harness clips to help manage the harness below the worksurface.

Soft edge worksurfaces and power and data access door and tray worksurfaces require reinforcement channel or other support on worksurfaces 60"W or larger.

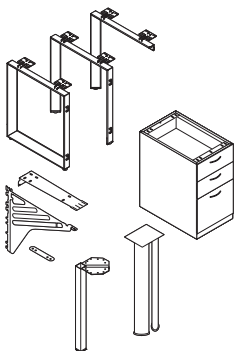

Worksurfaces greater than 72"W require additional support such as cantilevers, pedestals, or legs beyond the brace.

Wiring & Cabling

Chicago, New York, and Los Angeles have special requirements.

Underwriter Laboratory (UL) listed. The power and data tray has been designed to meet U.S. and Canadian national electrical and energy codes and most local building codes. Local electrical codes vary, so consult with your local authority having jurisdiction as they have final say if the products as installed are compliant with local code. Consult a qualified electrician or electrical engineer for proper installation of all electrical equipment.

Surface Materials

High-Pressure Laminate Worksurfaces

- Laminate
 - ▶ See *Surface Materials Reference Manual*.
 - Open Line laminate (option)
- A program including non-Steelcase laminates which are suitable for use on Steelcase products.
- ▶ See *Surface Materials Reference Manual*.

- Soft edge**
- 6615 Grey V5 Plastic

- 3 mm front edge**
- Plastic

- Back and side edges**
- Plastic color default to match 3 mm front edge

- Wood Veneer Worksurfaces**
- Wood veneer (standard)
 - Customiz stain (option)
 - Full-fill finish (option)

- Soft edge**
- 6615 Grey V5 Plastic

- Square (3 mm) edge profile**
- Wood veneer to match worksurface

- Front (user's) edge(s)**
- Wood edge band

Power and Data Access Door and Tray

- Door**
- Paint
 - Anodized aluminum

- Door bezel**
- 6694 Slate Plastic

- Inner and outer tray**
- 7237 Slate Paint

- End caps for outer tray**
- 6694 Slate Plastic

- Panel grommet**
- Plastic:
 - 6000 Black
 - 6009 Arctic White
 - 6249 Platinum Solid
 - 6654 Sand
 - 6697 Fog

- Pad**
- 6615 Grey V5 Plastic

Universal Systems
Worksurfaces with Soft
Edge, Power and Data
Access Door and Tray

Universal Systems Worksurfaces with Power Access Door

Power access door option on worksurfaces

allows for convenient pass through access to panel outlets.

► Specifying page 500

Systems straight worksurfaces with power access door

are available in a variety of widths and depths in modular and parametric dimensions.

Power access door provides desk top access and management of cords.

Power access door is only available on worksurfaces with a 1/2" cord drop.

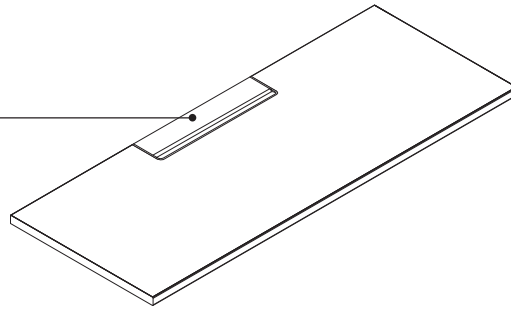

Actual Dimensions

Modular*	Parametric*	Centered	Left	Right	Left and Right	Left and Center	Right and Center	Left, Right, and Center
Straights – 18³/₈", 23¹/₂", and 29¹/₂"D*	Straights – 18"D - 36"D							
30"W	30"W – 35 ¹⁵ / ₁₆ "W	●						
36", 42", and 48"W	36"W – 53 ¹⁵ / ₁₆ "W	●	●	●				
54", 60", and 66"W	54"W – 71 ¹⁵ / ₁₆ "W	●	●	●	●			
72", 78", 84", 90", and 96"W	72"W – 120"W	●	●	●	●	●	●	●
Straight 120° Worksurfaces – 23¹/₂" and 29¹/₂"D								
48" and 60"W	N.A.	●	●	●				
72"W	N.A.	●	●	●	●	●	●	●
Square Edge Tops -18³/₈" and 23¹/₂"D								
30", 36", and 42"W	N.A.	●						
48", 54", 60", and 66"W	N.A.	●	●	●				
72", 78", 84", 90", and 96"W	N.A.	●	●	●	●	●	●	●

Dimensions

Cutout for Door

Width	16 ¹ / ₈ "
Depth	4 ¹ / ₄ "

*Tip: Modular 29¹/₂"D worksurface is only available up to 72"W. Worksurface width is available parametric from 18"W–120"W in 1/16" increments. Worksurface depth can be specified parametric from 18 3/8"D–36"D in 1/16" increments.

Product Details

High-Pressure Laminate Worksurfaces

PVC-free, 3 mm edge profiles are proprietary polyolefin blend for all solid colors and seven woodgrain finishes. Matching 1 mm side and back edges are also PVC-free.

▶ See *Surface Materials Reference Manual* for specific PVC-free availability.

3 mm front edge is specifiable. Back and side-edges match 3 mm front edge.

Edge profile finish for 3 mm front edge is specified separately from laminate color.

Wood Veneer Worksurfaces

Front (user's) edge profile is wood veneer with a square (3 mm) radius. Back edge and edge that joins to adjacent worksurfaces are flat. Wood edge color matches finish specified for worksurface.

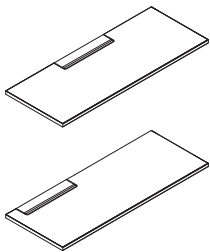

Scallops are omitted on all worksurfaces with a power access door.

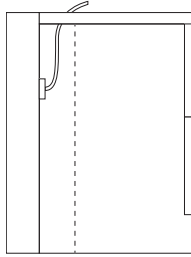

Power access door provides access to power outlets in the panel.

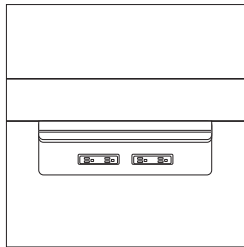

Currency storage with recessed back should be used when storage will be placed in front of a power outlet.

Recessed back storage features a 3³/₄" cavity to allow access to outlets below the worksurface.

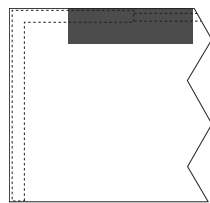
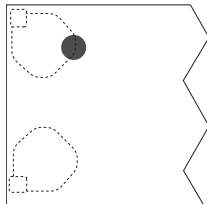

Left and right configured power access doors will interfere with FrameOne post leg support and freestanding end panels (UE18, UE24, and UE30).

Surface Materials

High-Pressure Laminate Worksurfaces

- Laminate
 - ▶ See *Surface Materials Reference Manual*.
 - Open Line laminate (option)
- A program including non-Steelcase laminates which are suitable for use on Steelcase products.
- ▶ See *Surface Materials Reference Manual*.

3 mm front edge

- Plastic

Back and side edges

- Plastic color default to match 3 mm front edge

Wood Veneer Worksurfaces

- Wood veneer (standard)
- Customiz stain (option)
- Full-fill finish (option)

Square (3 mm) edge profile

- Wood veneer to match worksurface

Front (user's) edge(s)

- Wood edge band

Power Access Door

Door

- 4799 Platinum Metallic
- 7207 Black
- 7241 Arctic White
- 7360 Merle
- 8043 Clear Anodized Aluminum

Door bezel

- 6527 Merle

Worksurface-Mounted Retractable Power and Data

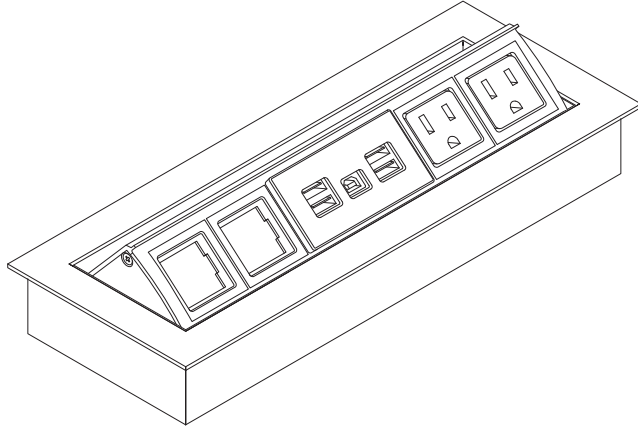

Product Details

Standard with four power receptacles, two data openings and faceplates to accommodate customer supplied voice/data jacks.

Optional with two power/two data/one USB or three power/one data/one USB.

Includes 10' power cord with three-prong plug.

Can mount in any location on worksurface.

Requires a 4" x 11" hole with square corners be field cut in the worksurface.

Specify cord and cable management accessories separately to manage cords and cables back to panel.

Surface Materials

Housing

- Anodized aluminum

Receptacle

- Black

Metal Center Drawers

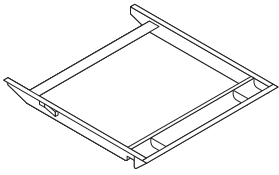

► Specifying, page 548

Product Details

Metal center drawer provides convenient personal storage beneath the worksurface.

Tray for pencils and paper clips is included.

Locks are not available on center drawers. For secure storage, use pedestals and other lower storage with locks.

Connections

Fits on all 24"D and 30"D panel-supported worksurfaces and 24"D, 30"D, and 36"D desks.
Tip: 24"D desk can only use the 18¹/₈"D center drawer.

Installation is in the field.

Drawer frame and attaching hardware are included for field installation.

Wiring & Cabling

Grommets cannot be used over center drawers.

Surface Materials

Center drawer

- Paint

Tip: Drawer will match the color of the supports. If you want a complementary color, you should order the drawer separately for field installation.

Application Topics

Drawer should be placed approximately 4" from the left or right end to allow for the attachment of cantilevers or end panels.

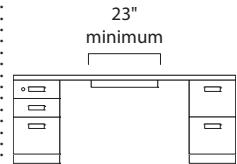

Kneespace clearance needed is 23"W.

Actual Dimensions

Depth	18 ¹ / ₈ " or 23"
Inside depth	14 ¹ / ₂ " or 19 ¹ / ₂ "
Width	21 ¹ / ₂ "
Inside width	19 ¹ / ₂ "
Height	2 ³ / ₈ "
Inside height	2"

Transaction Worksurfaces

Transaction worksurface

provides a surface that can be used by standing visitors or serve as a shelf.

► Specifying, page 544

Worksurface has a wood core with a High-Pressure Laminate or wood veneer surface and is 1 3/16" thick.

Attachment brackets are included.

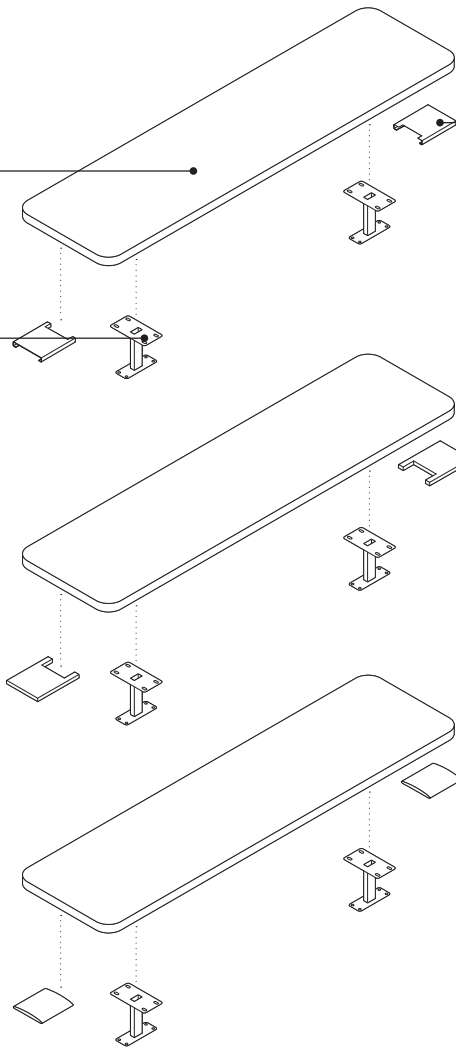

Shortened top caps are included with the transaction worksurface. Top caps are available in thin, square, or oval styles and are compatible with same-height or change-of-height applications.

Product Details

High-Pressure Laminate Worksurfaces

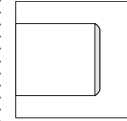

3 mm edge profile

3 mm edge profile is plastic and is specified separately from laminate color.

Wood Veneer Worksurfaces

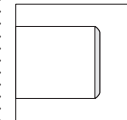

Edge profile is wood veneer with a square (3 mm) radius. Wood edge color matches finish specified for worksurface.



Edge profile is applied to all edges.



Actual Dimensions

Square and Oval		Thin	
A	B	A	B
15"	23" for use on 30"W panel	15"	28" for use on 30"W panel
15"	29" for use on 36"W panel	15"	34" for use on 36"W panel
15"	35" for use on 42"W panel	15"	40" for use on 42"W panel
15"	41" for use on 48"W panel	15"	46" for use on 48"W panel
15"	53" for use on 60"W panel	15"	58" for use on 60"W panel

Tip: Wood veneer transaction worksurfaces are not available in 23"W.

Connections

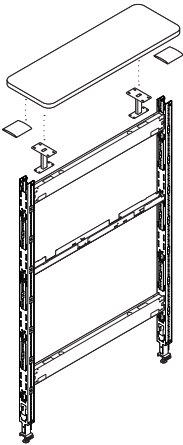

Transaction work surface support brackets connect to the top of a horizontal connecting bar. Horizontal bar must be connected to junctions in top position.

Transaction work surfaces cannot be used when a transparent window, pass-thru window, or consolidation point cabinet are assembled at the top of a panel.

A transaction top work surface cannot be added to a panel segment with a 6" stacker.

In square and oval trim applications, a transaction top cannot be used on a 48"H panel when the panel is connected to a taller panel in a change-of-height condition.



A transaction top may be used on a 48"H panel connected to a taller panel in a change-of-height condition, but the taller panel must comprise of a 48"H base junction with a stacking junction to achieve the taller height.

Spanning two panels with thin trim is possible.

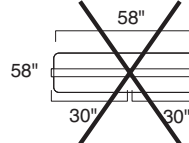
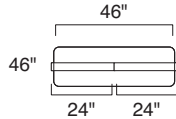
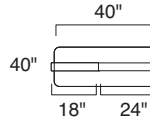
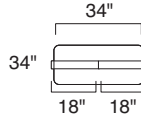
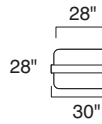

Exception: 58"W transaction work surface cannot span multi-panels because it has an additional support bracket that conflicts with the junction between two 30"W panels.

Spanning two panels with square or oval trim is possible.

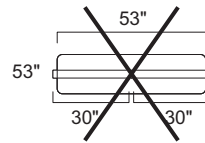
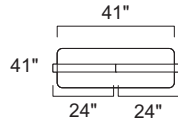
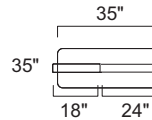
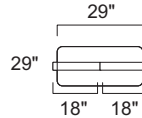

Exception: 53"W transaction work surface cannot span multi-panels because it has an additional support bracket that conflicts with the junction between two 30"W panels.

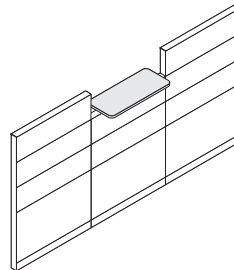

Width of transaction work surface with thin trim is 2" shorter than the width of corresponding panel to accommodate change-of-height applications.

Width of transaction work surface with square and oval trim is 7" shorter than the width of corresponding panel to accommodate change-of-height applications.

Panels on one or on both sides of the transaction work surface can be higher or lower than the panel that supports the transaction work surface.

Transaction work surfaces with thin or oval trim include top trim that accommodates all standard and change-of-height applications (one end or both ends).

Transaction work surfaces with square trim include top trim that accommodates both standard and slim change-of-height applications (one end or both ends). Change-of-height option must be specified when used adjacent to cable management change-of-height (one end or both ends).

Recommended standing height for transaction work surface is achieved by attaching it to 42"H panels.

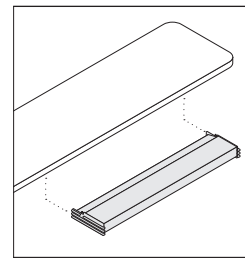

Utility2 shelf lights can be installed beneath transaction work surfaces using screws and keyhole slots in light fixture.

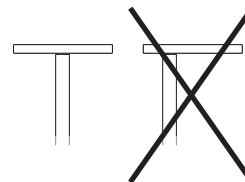

Transaction work surface must be centered on the panel.

Wiring & Cabling

Transaction work surface blocks cable routing in the top cable tray but cable routing is still available lower in the panel.

Surface Materials

High-Pressure Laminate Worksurfaces

- Laminate
- ▶ See *Surface Materials Reference Manual*.
- Open Line laminate (option)
- A program including non-Steelcase laminates which are suitable for use on Steelcase products.
- ▶ See *Surface Materials Reference Manual*.

Edges

- Plastic

Top caps

- Paint
- Wood

Support brackets

- Black paint only

Wood Veneer Worksurfaces

- Wood veneer (standard)
- Customiz stain (option)
- Full-fill finish (option)

Square (3 mm) edge profile

- Wood veneer to match work surface

Top caps

- Paint
- Wood

Support brackets

- Black paint only

Universal Panel-Mounted Worksurface Supports

For Answer Panel Applications

On-module supports can be used to panel support worksurfaces in various configurations.

► Specifying, page 552

Worksurface supports feature alignment tab used to set a depth for Universal Systems Worksurfaces—with 1/2" cord drop. This tab is bent down when installing full-depth worksurfaces.

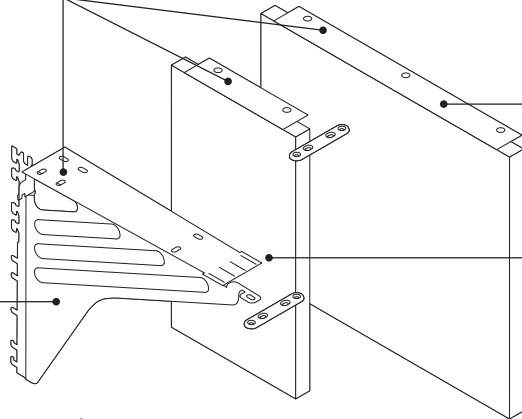

Cantilever can be used to panel-support a worksurface at any height.

End panel can be used to support the end of a worksurface.

Center support panel can be shared by two worksurfaces and may be required for longer runs of worksurfaces.

Side support brackets can be used to support the ends of straight and corner worksurfaces and to support the back corner of any corner worksurface.

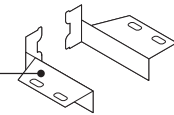

Product Details

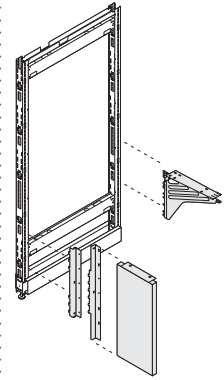

On-module work surface supports engage the slots in the vertical uprights of Answer panels.

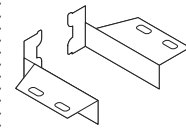

Side support brackets support worksurfaces at any height in 1" increments. Brackets ship as a left- and right-hand pair and are ordered separately.

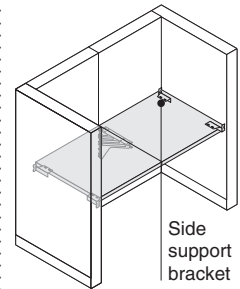

Side support brackets can be used to support the end of a worksurface that is wrapped by a panel with the same width dimension that matches the worksurface depth.

Actual Dimensions

	Cantilever	Center support panel	End panel
Height	12 1/4"	28 1/2" or 40 7/8"*	28 1/2" or 40 7/8"*
Depth	15 1/2"	11"	23 3/4" or 29 3/4"
Glide Range	N.A.	1 1/4"	1 1/4"

*Height dimensions include the thickness of a worksurface.

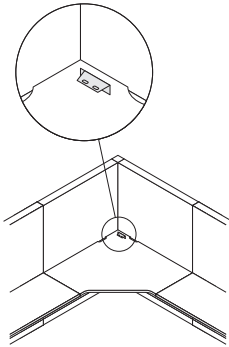

Single side support bracket can be used to support the rear corner of corner, extended corner, and 120° corner worksurfaces.
Tip: For off-module fin wall applications, the single side support bracket must be handed appropriately for connection to the fin wall.

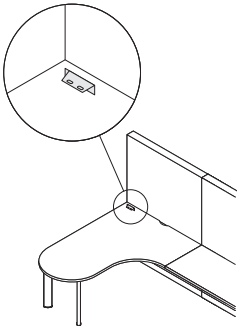

Single side support bracket can be used to support the user's side rear corner of bullet peninsula, angled peninsula, visitor, jetty, and bubble jetty worksurfaces.

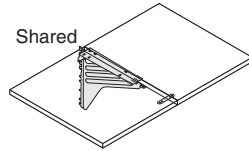
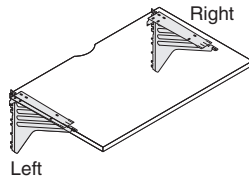

Cantilevers support worksurfaces at any height in 1" increments. Cantilever is non-handed and can be used to support either end of a work surface, or shared to support two worksurfaces at the same height simultaneously. One tie plate ships with each cantilever.

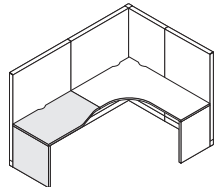

30"D straight, tapered, and transition cantilevered worksurfaces require additional floor support along the front edge, such as a pedestal, end panel, post leg, side support bracket, or an adjacent return work surface.

26 1/16"D - 30"D parametric straight cantilevered worksurfaces require additional floor support along the front edge, such as a pedestal, end panel, post leg, side support bracket, or an adjacent return work surface.

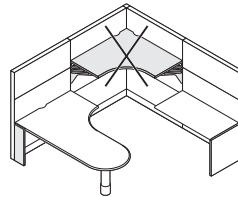

Adjacent cantilevered worksurfaces must be the same height in order to connect with a tie plate and provide panel stability.
Tip: Answer panel junctions can accommodate only one support at each work surface seam.

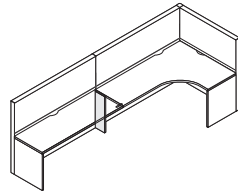

Center support panel is an alternative to a cantilever in supporting longer runs of worksurfaces for additional panel stability. Refer to the applicable panel stability guidelines for specific requirements.

Center support panels are available in seated and standing heights, and cannot be used in freestanding applications or as a substitute for an end panel. One tie plate ships with each center support panel.

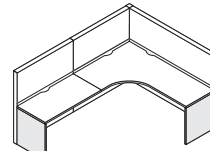

End panels can be used to support the end of a work surface for additional panel stability. Refer to the applicable panel stability guidelines for specific requirements.

End panels are available in seated and standing heights, and cannot be used in freestanding applications.

All panel mounted supports can be removed and repositioned later without any permanent damage to panels or skins.

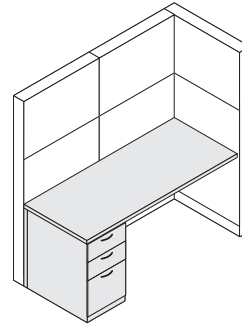

Pedestals and lateral files with a filler can be used to support the end of a work surface in place of an end panel.
▶ See *Storage Specification Guide*.

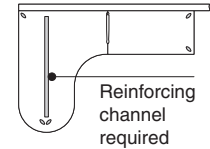
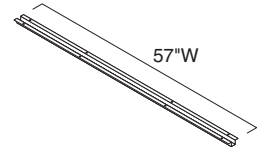

Work surface spans greater than 54" require additional support of a cantilever, pedestal, intermediate support, or leg. Exception: Worksurfaces can span up to 60" in heavy load applications and up to 72" in light load applications if a TS7WKSPT reinforcing channel is used. Reinforcing channel must be specified separately.
▶ Specifying, page 553

Surface Materials

Side support bracket and reinforcing channel

- Black paint only

Cantilever, center support panel, and end panel

- Paint

Application Topics

Worksurfaces greater than 30"D can only be used in freestanding applications and cannot be panel mounted.

Worksurfaces used in panel-supported installations must follow applicable panel stability guidelines.

- ▶ Page 140

Off-Module Worksurface-to-Panel Connector

Connector attaches into the slotted channels of the panel junctions.

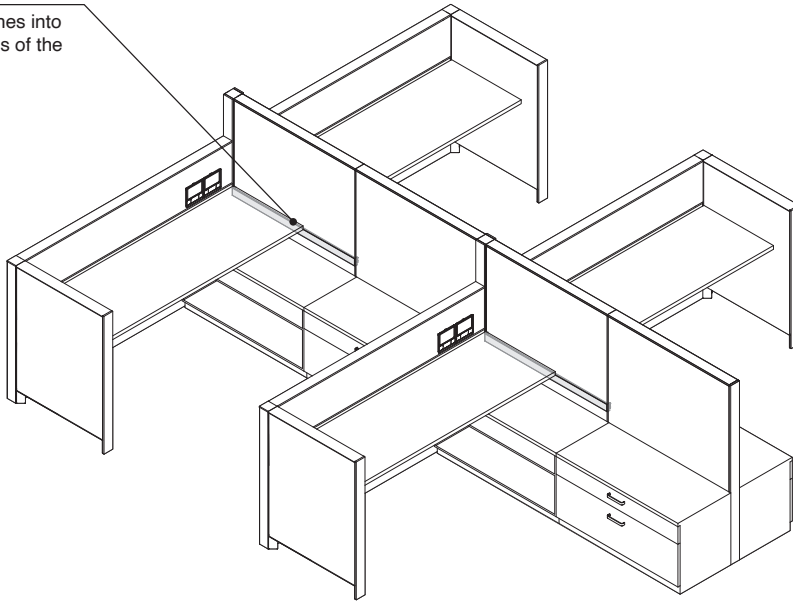

Product Details

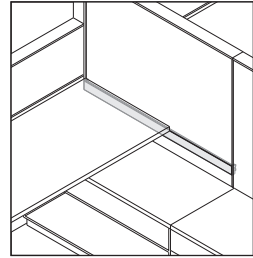

Connects 18"D to 30"D worksurfaces to wider panels eliminating the need to match panel width to work-surface depth. Replaces side supports, cantilevers, and the need for front edge support with worksurfaces greater than 26"D.

Actual Dimensions

Depth	1/2"
Width	34", 30", 36", 42", 48", 60", or 72"
Height	3"

Application Topics

Worksurface can be positioned anywhere along the width of the off-module connector.

Off-module worksurface to panel connector cannot be used at the same elevation on adjacent in-line panels.

Off-module worksurface-to-panel connector can be used to support the diagonal end of a Universal straight 120° worksurface.

Off-module worksurface to panel connector can support a single worksurface only.

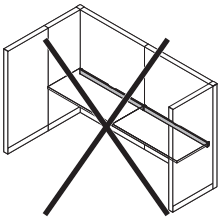

Off-module worksurface to panel connector cannot replace cantilevers and side support brackets when worksurface is parallel to the panel.

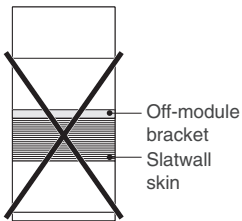

Off-module worksurface to panel connector cannot be used in front of or on the adjacent panel next to a 12"H or a 24"H slatwall skin positioned in the second 12" skin module from the base of the panel.

Surface Materials

- Connector**
- Paint

FrameOne Legs and Supports for Universal Worksurfaces

Legs and supports share a common visual with FrameOne bench and support Universal worksurfaces in freestanding, storage-supported, or panel-supported applications. ▶ Specifying page 556

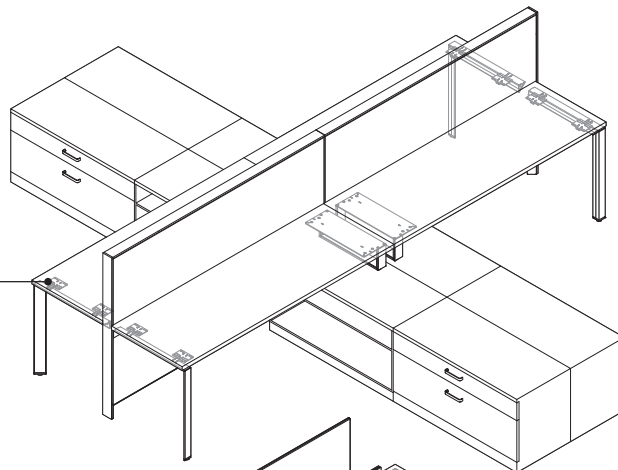
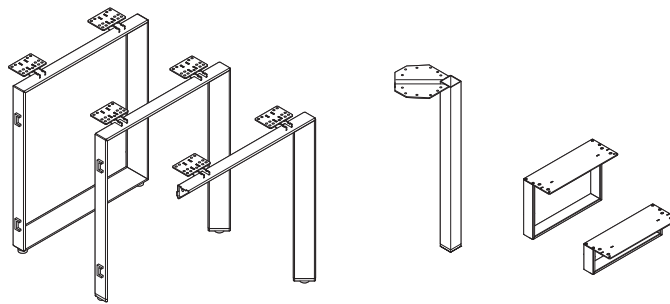

Spacers between top of legs and worksurface provide a floating look to the worksurface and match visual of FrameOne bench.

Intermediate support is used with Universal One-High or 1.5-High storage as a worksurface support allowing for nesting of low storage.

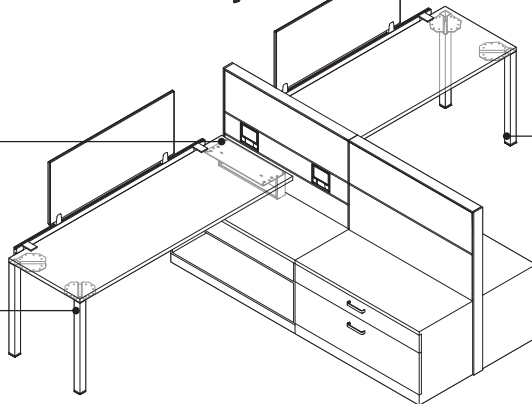

Leveling glide allows worksurface height to be adjusted on uneven floors.

Post leg is square to provide a complementary visual to FrameOne legs. Post leg can be used as a column support.

Product Details

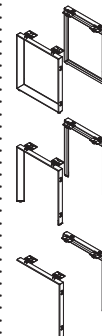

Closed, open, and half-loop legs are handed when panel supporting and must be specified left or right when facing the front of the worksurface. Freestanding tethered and table versions are non-handed.

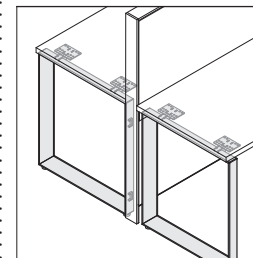

Closed, open, and half-loop legs are available in panel supporting versions. They support the ends of worksurface; they are not shared supports between two worksurfaces.

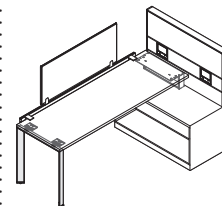

Closed and open-loop legs are available in tethered versions in which one side of the worksurface is attached to a panel or storage.

Dimensions

	Closed, Open, and Half-Loop Legs	Post Leg	Intermediate Supports	
			For One-High storage	For 1.5-High storage
Height*	28 1/2"	28 1/2"	28 1/2"	28 1/2"
Height	N.A.	N.A.	11 1/4"	5 1/4"
Depth	24" or 30"	N.A.	16"	16"
Width	N.A.	N.A.	23/16"	23/16"
Glide range	2 1/4"	1"	N.A.	N.A.

*Height dimensions include the thickness of the worksurface.

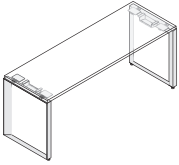

Closed and open-loop legs are available in table versions in which both sides of the worksurface are supported by the legs. Post legs can also be used to create freestanding tables.

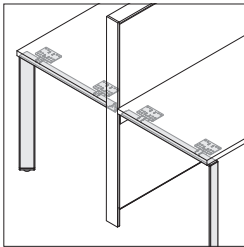

Half-loop leg is always panel supporting, however panels cannot exceed 48"H or support overhead storage above.

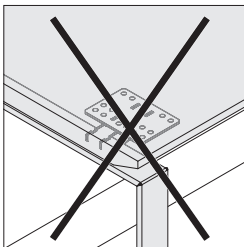

Closed, open, and half-loop legs do not align properly with knife-edge worksurfaces. Instead use cantilevers.

▶ See page 232 for knife-edge worksurface application guidelines.

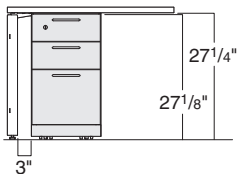

27"H mobile, freestanding, or fixed pedestals do not fit flush to the inside of the closed, open, or half-loop leg, there is a 3" gap due to the worksurface support plate. 25½"H freestanding pedestals or 21"H mobile pedestals will fit flush.

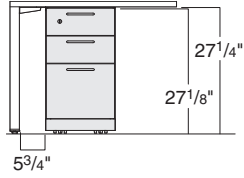

27"H mobile, freestanding, or fixed pedestals do not fit flush to the inside of the post leg, there is a 5¾" gap due to the worksurface support plate. 25½"H freestanding pedestals or 21"H mobile pedestals will fit flush.

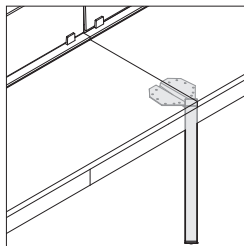

Post leg can be shared between two worksurfaces.

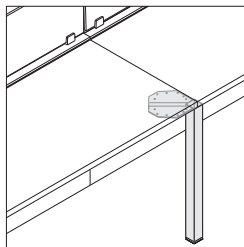

Post leg in shared applications can be square or oriented angled to the front edge of the worksurface.

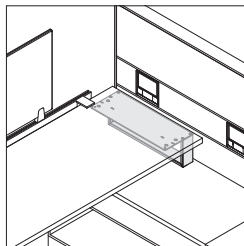

Intermediate supports replace the need for other types of worksurface support when used with One-High or 1.5-High Universal storage.

Steel top storage requires additional bracing inside the storage when used with an intermediate support. Bracing is an option to the intermediate support and is specified to match the width of the storage.

Bracing is field-installed.

Number of braces is determined by the orientation of the intermediate support to storage. It is not determined by the orientation of the worksurface to storage.

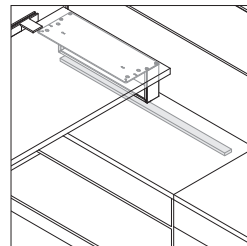

Side-to-side (parallel) orientation of intermediate support relative to storage requires one brace.

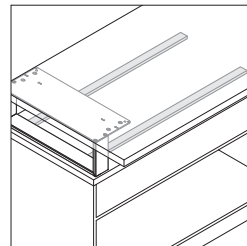

Front-to-back (perpendicular) orientation of intermediate support relative to storage requires two braces.

Storage with laminate or wood tops do not require additional bracing with intermediate support.

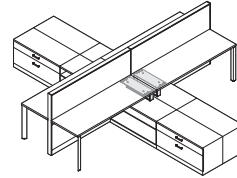

Side-to-side (parallel) application of intermediate support allows worksurface to be oriented perpendicular to storage.

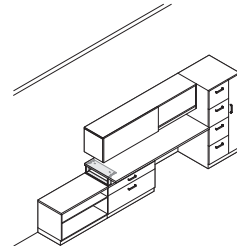

Front-to-back (perpendicular) application of intermediate support allows worksurface to be oriented in-line with storage.

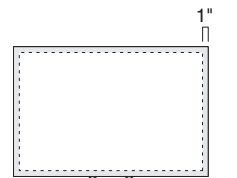

Intermediate support must be at least 1" from the front, back, or side edges of the storage unit to allow clearance for installation.

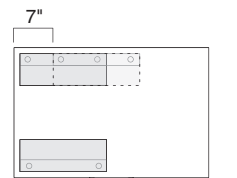

On cabinets with steel tops, in parallel applications, the intermediate support can be positioned left or right 1" or 7" from the side edge of the storage unit to align with bracing hole locations and can be positioned anywhere front to back on the unit. On cabinets with laminate or wood tops, in parallel applications, the intermediate support can be positioned left or right anywhere between 1" and 7" from the side edge of the storage unit.

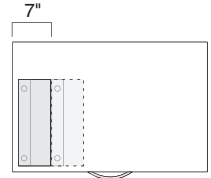

On cabinets with steel tops, in perpendicular applications, the intermediate support can be positioned left or right 1" or 7" from the side edge of the storage unit to align with bracing hole locations and can be positioned anywhere front to back on the unit. On cabinets with laminate or wood tops, in perpendicular applications, the intermediate support can be positioned left or right anywhere between 1" and 7" from the side edge of the storage unit.

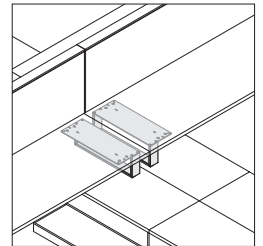

Worksurfaces 18"D to 24"D allow intermediate support to be positioned below the worksurface 1" from the front or back.

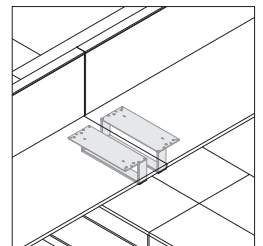

Worksurfaces 24½" to 30"D must be placed a minimum of 1" from the front or back edge, and a maximum of 7" from the front or back edge.

Intermediate support cannot support worksurfaces larger than 30"D.

FrameOne Legs and Supports for Universal Worksurfaces, continued

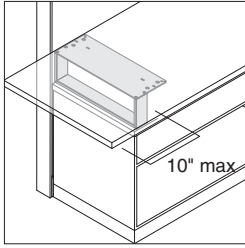

Worksurface may extend up to 10" maximum overhang of intermediate support as long as the other end of the worksurface is anchored to the panel.

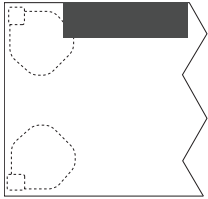

FrameOne post legs will interfere with left and right oriented power access doors on Universal worksurfaces.

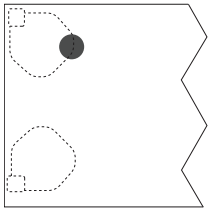

FrameOne post legs will interfere with left and right oriented grommet cutouts in parametric straight Universal worksurfaces.

Surface Materials

Legs and intermediate support

- Paint

Spacer caps for panel attached legs

- Black plastic only

Glide cap for legs

- 6694 Slate only

Shipping

Closed, open, and half-loop legs are packed in boxes of six when ordered on the same line item.

Bracing for intermediate supports ship separately from intermediate supports and are field installed into storage cases.

Infills for FrameOne Legs for Universal Worksurfaces

Infills for FrameOne Legs for Universal Worksurfaces

Infills are available in laminate and veneer and are used with open and closed loop FrameOne legs.

► Specifying page 557

Infills provide added privacy.

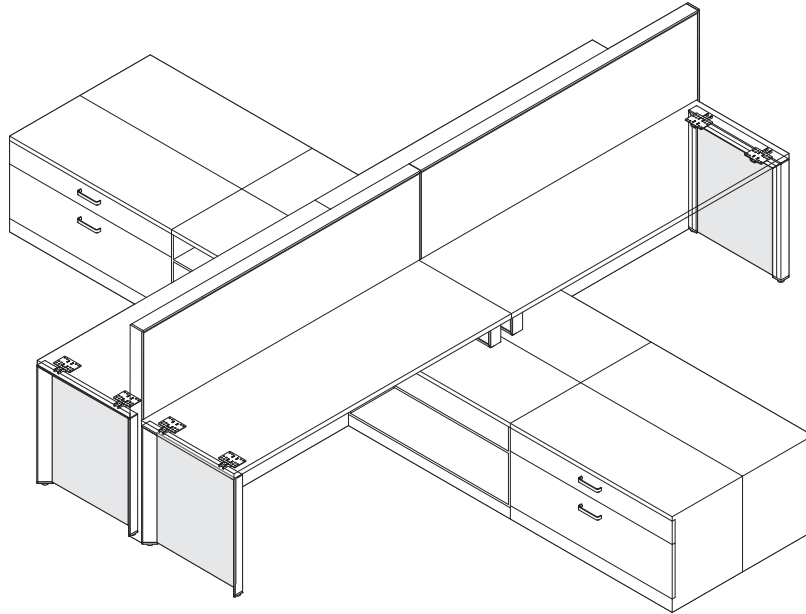

Product Details

Infills can be used with both panel connected or freestanding versions of open and closed loop FrameOne legs for universal worksurfaces.

Connectors attach to the back side of the legs.

Surface Materials

Surfaces

- Laminate
- Veneer

Planning Dimension

Infills are available 24"W and 30"W.

Legs and Columns for Universal Systems Worksurfaces

Without Alignment Tab

Legs are available to support worksurfaces in free-standing or panel-supported applications.

► Specifying, page 558

Double post C-leg

can be used on a single worksurface or in a shared application.

Post leg can be used on a single worksurface. Non-locking caster and glide versions are available.

Column is 4" in diameter and can be used as a column support on a single worksurface. Adjustable and non-adjustable versions are available.

Double post leg can be used as a column support on a single worksurface or to support a shared application.

Adjustable-height leg can be used with a single worksurface. Locking caster and glide versions are available.

Adjustable-height leg adjusts from 25½"H to 31½"H in ¾" increments.

Tapered post leg available in single or package of four.

Support plate can be used with a double post leg to join and support two worksurfaces. Plate is 14"D or 20"D and 31½"W.

Leveling glide allows worksurface height to be adjusted on uneven floors.

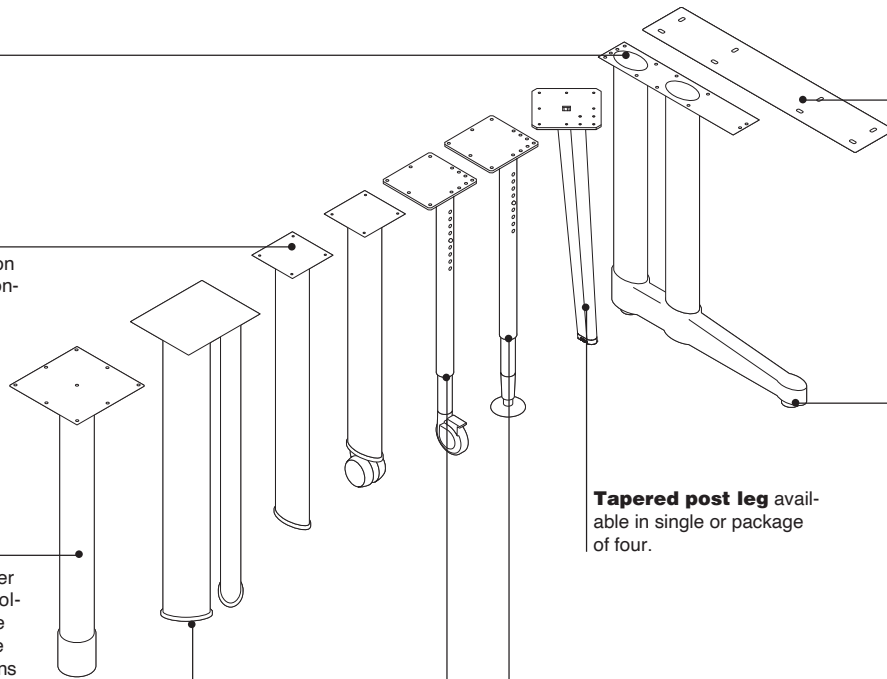

Actual Dimensions

	Column	Adjustable column	Double post leg	Post leg	Adjustable-height leg	Tapered post leg	Double post C-leg	Support plate
Height*	28½"	28½"–31⅝"	28½" or 40⅞"	26", 28½", or 40⅞"	25½"– 31½"	28½"	28½"	N.A.
Glide range, for legs equipped with glides	1½"	3⅛"	¾"	¾"	¾"	½"	¾"	N.A.

*Height dimensions include the thickness of a worksurface.

Product Details

Legs support Systems Worksurfaces at 26"H nesting, 28½"H standard, 40⅞"H standing or 25½"H to 31½"H adjustable heights.

Legs for Systems Worksurfaces do not include alignment tabs. Pilot holes help the installer locate the proper leg position under the worksurface.



45° orientation

Post legs are always installed at a 45° orientation.

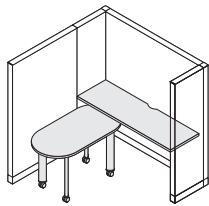

26"H nesting height legs allow worksurfaces to nest underneath an adjacent worksurface supported with 28½"H legs or a panel-supported worksurface.

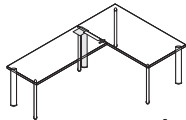

Double post leg can be used in a shared application with a support plate, or it can be used as a column support for spanner, jetty, bubble jetty, bullet peninsula, angled peninsula, and linking peninsula worksurfaces in panel-mounted applications.

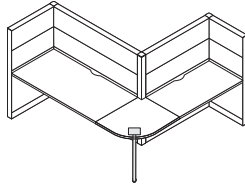

Post leg, in conjunction with two cantilevers or center support panels, can be used as column support for linking worksurfaces.

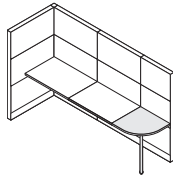

Post leg, in conjunction with a side support bracket, can be used to support the end of a visitor or taper-flat worksurface.

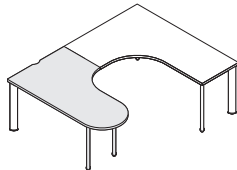

Two post legs can be used in place of one double post leg as column support for spanner, jetty, bubble jetty, bullet peninsula, and angled peninsula worksurfaces for added stability.

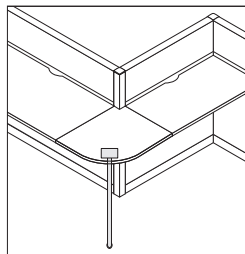

Standing-height post or double post legs can be used as column support in panel-mounted applications only.

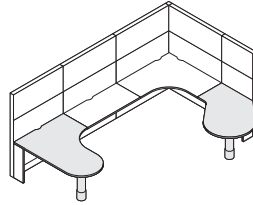

Column can be used on spanner, bullet peninsula, angled peninsula, linking peninsula, jetty, and bubble jetty worksurfaces in panel supported applications.

For Answer Freestanding desk applications, column

can be used on bullet peninsula and jetty worksurfaces. Adjustable and non-adjustable versions are available.

Column cannot be used in a shared application.

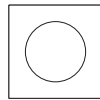

Bottom View Column



Bottom View Post Leg

Column is not recommended for applications that include post legs because it has a round shape, while post legs are more of an elliptical shape. Use single or double post legs as a column support in applications that include other post legs.

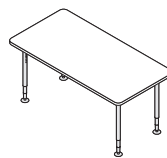
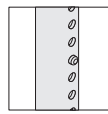

Adjustable-height legs adjust from 25½"H to 31½"H in ¾" increments. Legs can be used to support the primary worksurface, or legs can support a worksurface in a nesting application.

The adjustable-height leg with casters cannot support freestanding worksurfaces that are less than 24" deep.

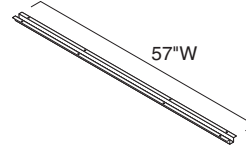

57"W

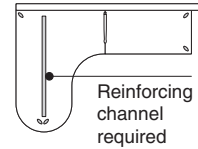

Reinforcing channel required

Worksurface spans greater than 54"

require additional support of a cantilever, pedestal, intermediate support, or leg. Exception: Worksurfaces can span up to 60" in heavy load applications and up to 72" in light load applications if a TS7WKSPT reinforcing channel is used. Reinforcing channel must be specified separately. ▶ Specifying, page 553

Surface Materials

Post legs, C-leg, adjustable-height legs, and adjustable column

- Paint

Post leg caster

- Black plastic only

Support plate and reinforcing channel

- Black paint only

Application Topics

Stability Guidelines

- ▶ Page 140

Knife Edge Worksurface Application Guidelines

When planning an L-configuration, two UFB flat brackets should be used to support the worksurfaces. A cantilever is not wide enough to support the gap where the knife edge worksurface comes together.

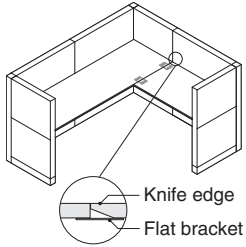

Freestanding L-configuration should be avoided due to profile on the backside of the worksurface.

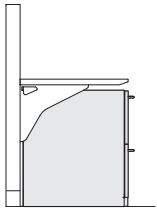

25 1/2"H Pedestal
(cantilever supported worksurface)

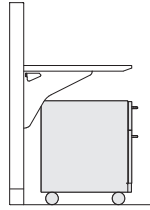

Boxfile
(cantilever supported worksurface)

Compatible storage includes 25 1/2"H pedestal with freestanding conversion kit, box/file mobile pedestals, and 1-high storage.

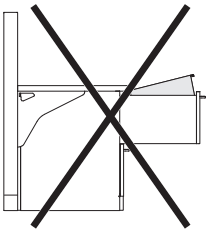

Knife Edge with 27"H Lateral
and 27"H Pedestal

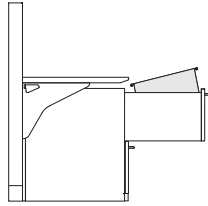

Knife Edge with 25 1/2"H Pedestal

Knife edge worksurface over 27"H storage can make files difficult to access. Use a 25 1/2"H pedestal that is flush with the front edge of the worksurface to avoid this issue.

Knife edge worksurfaces require reinforcement channels for unsupported spans greater than 48". Use TS7WKSPT39 for 54"W worksurfaces, TS7WKSPT for 60"W and 66"W worksurfaces, and TS7WKSPT72 for 72" worksurfaces.

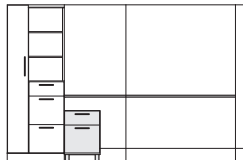

Although a 25 1/2"H pedestal looks good when paired with knife edge, keep in mind that it does not align with other storage – drawers and base trim do not align. Use a box/file mobile pedestal instead.

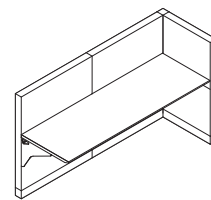
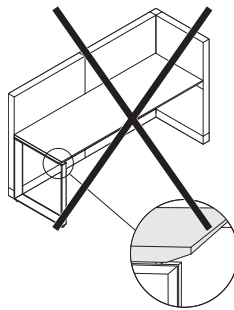
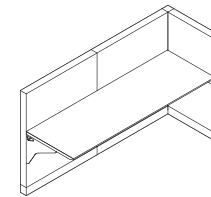
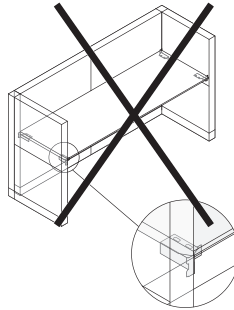
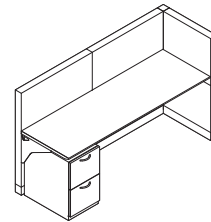
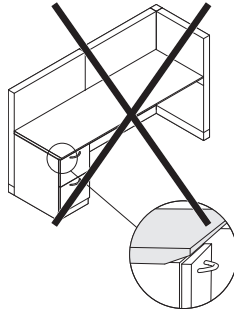
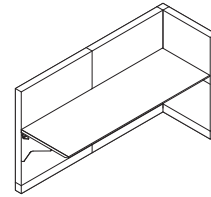
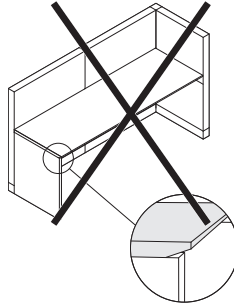

End panels, 27"H standard pedestals, side support brackets and FrameOne legs for Universal do not align properly with knife edge worksurfaces. Instead, use cantilevers as shown.

**Side support brackets will work to support the back end of a worksurface; front end is where they won't align properly.

Understanding Worksurface Screens



Statement of Line **234**



Universal Privacy/Modesty Screens	236
Universal Privacy Screens and Aligners	238
Sarto Privacy/Modesty Screens	239
Sarto Privacy Screens	240
Divisio Side Screen	241

Statement of Line

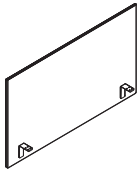

Understanding
 ▶ Page 236
 Specifying
 ▶ Page 563

Universal Privacy/Modesty Screens

	Height Above Worksurface	42"W	48"W	54"W	60"W	66"W
Privacy Mount Height*	19 ¹ / ₅ "H	●	●	●	●	●
Privacy/Modesty Mount Height*	13"H	●	●	●	●	●

Tip: Overall screen height is 25⁷/₁₀"H.

**Privacy mount height measures 48" from the floor to the top of the screen and privacy/modesty mount height measures 42" from the floor to the top of the screen. Privacy mount shown.*

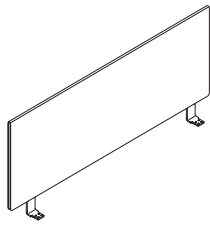

Understanding
 ▶ Page 238
 Specifying
 ▶ Page 564

Universal Privacy Screens

	24"W	30"W	36"W	42"W	48"W	54"W	60"W	66"W	72"W	78"W	84"W	90"W	96"W
13 ¹ / ₂ "H	●	●	●	●	●	●	●	●	●	●	●	●	●
19 ¹ / ₂ "H	●	●	●	●	●	●	●	●	●	●	●	●	●

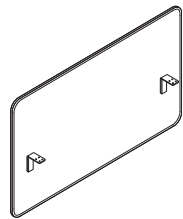

Understanding
 ▶ Page 239
 Specifying
 ▶ Page 566

Sarto Privacy/Modesty Screens

	24"W	29"W	42"W	46"W	48"W	54"W	58"W	60"W	66"W	70"W
24"H	●	●	●	●	●	●	●	●	●	●
30"H	●	●	●	●	●	●	●	●	●	●

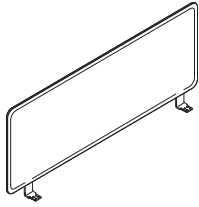

Understanding
 ▶ Page 240
 Specifying
 ▶ Page 568

Sarto Privacy Screens

	24"W	29"W	30"W	36"W	42"W	46"W	48"W	54"W	58"W	60"W	66"W	70"W	72"W	78"W	84"W	90"W	96"W
13 ¹ / ₂ "H	●	●	●	●	●	●	●	●	●	●	●	●	●	●	●	●	●
19 ¹ / ₂ "H	●	●	●	●	●	●	●	●	●	●	●	●	●	●	●	●	●
24"H	●	●	●	●	●	●	●	●	●	●	●	●	●	●	●	●	●
36"H	●	●	●	●	●	●	●	●	●	●	●	●	●	●	●	●	●

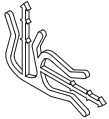

Understanding
 ▶ Page 239
 Specifying
 ▶ Page 570

Sarto Alignment Bracket



Understanding
 ▶ Page 241
 Specifying
 ▶ Page 571

Divisio Side Screen

29 ¹ / ₂ "D	
11 ⁵ / ₈ "H	●

Universal Privacy/Modesty Screens

Universal privacy/modesty screen provides a boundary element for height adjustable desks and fixed worksurfaces. It can be used with Ology, Migration, Series 5 and 7 worksurfaces, Elective Elements, Universal tables, and Universal panel-mount worksurfaces.

► Specifying, page 563

Universal privacy/modesty screens are available in one height, 25⁷/₁₀" , with two mount location options to provide either privacy or privacy/modesty.

Universal privacy/modesty screens cannot be used on surfaces that have integrated rails or an additive SOTO rail.

Universal privacy/modesty screen is pin tackable.

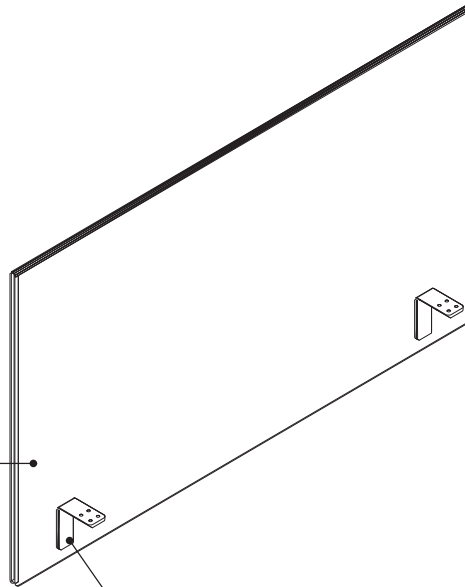

The screen is attached to the worksurface using simple L-brackets and 1" screws.

Product Details

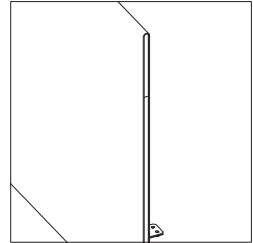

The edge of the screen is comprised of two different materials. The upper segment is merle plastic. The lower portion is PET which can be specified in medium heather grey to provide contrast or dark heather grey for a uniform visual.

The screen may be used on 3/4"-1 1/2" thick worksurfaces.

The width of the screen can be equal to or less than the width of the worksurface to which it will attach. Some restrictions apply due to location of worksurface legs and supports.

Surface Materials

Screen

- Fabric
- See *Surface Materials*, page 668.

Edge (upper segment)

- 7360 Merle

Edge (lower segment)

- P630 Medium Heather Grey PET
- P631 Dark Heather Grey PET

Brackets

- 7360 Merle

Actual Dimensions

Universal Privacy/Modesty Screen

Width	42", 48", 54", 60", or 66"
Height	25 ⁷ / ₁₀ "
Weight	9.79 lb, 10.315 lb, 10.84 lb, 11.365 lb, 11.89 lb
Thickness	3/4"

Application Topics

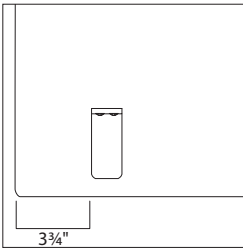

Universal privacy/modesty screen mounts to worksurfaces using simple L-brackets and screws. The brackets are positioned 3 3/4" in from each side of the screen.

Screen height attachment locations are determined when specifying privacy (top of screen will be at 48") or privacy/modesty (top of screen will be at 42"). The location cannot be changed in the field.

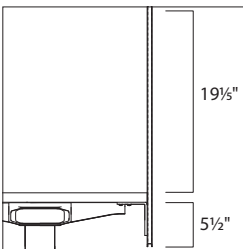

Privacy configuration provides 19 1/2" of screen above the worksurface and 5 1/2" of screen below the worksurface. The height is measured from the top of the mounting surface to the top of the screen, and from the bottom of the mounting surface to the bottom of the screen. The top of the screen will align with the bottom of the top trim on a 48"H Answer panel.

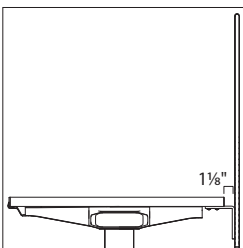

Screen can be mounted with a 1 1/8" cord drop or flush with no cord drop.

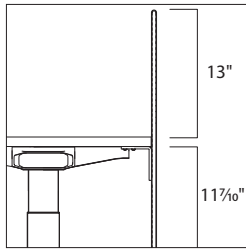

Privacy/modesty configuration provides 13" of screen above the worksurface and 11 7/10" of screen below the worksurface. The height is measured from the top of the mounting surface to the top of the screen, and from the bottom of the mounting surface to the bottom of the screen. The top of the screen will align with the bottom of the top trim on a 42"H Answer panel.

Both the privacy and privacy/modesty configurations allow the height-adjustable desks to be lowered to the lowest position (22") while preserving pinch point gap. Privacy version will not interfere with integrated storage.

Universal privacy/modesty screens can be used with universal worksurfaces and tables where surface supports and leg brackets are not in same location of the screen L-bracket attachment points.

- Example 1 – Worksurfaces supported by a panel side bracket or cantilever can accept privacy/modesty screen placed 6" in from end with these brackets.
- Example 2 – Tables with double elliptical post C-legs can accept screens 6" shorter than total table width but not same width.

Privacy/modesty screens can also be used with Elective Elements surfaces with some restrictions when combined with gate leg or the Elective Elements adjustable-height leg.

Privacy modesty screens must never be wider than the surface to which they are attached.
Tip: It is recommended that CET SmartTools Planning aid be used to ensure proper application of screen to work-surface or tables.

When used with One-High integrated storage, Universal privacy/modesty screens must be a minimum of 18" shorter than worksurface width to allow for pinch point clearances.

Universal Privacy Screens and Aligners

Universal privacy screens provide a boundary and privacy element for height adjustable desks and fixed worksurfaces. It can be used with Ology, Migration, Series 5 and 7, Elective Elements, panel-supported Universal worksurfaces, and TS Series worksurfaces.

► Specifying, page 564

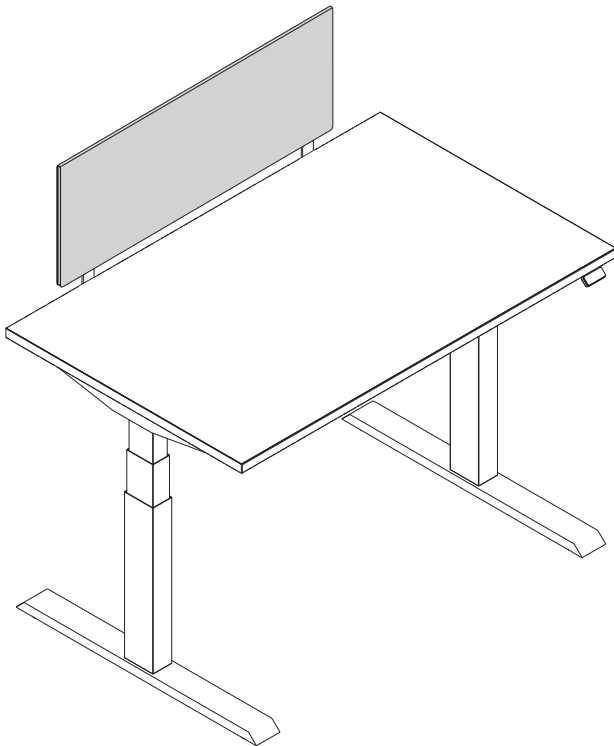

Actual Dimensions

Height	12½" or 18½"
Overall Height	13½" or 19½"
Width	24", 30", 36", 42", 48", 54", 60", 66", 72", 78", 84", 90", or 96"

Tip: 13½"H screen aligns with a 42" datum from the floor. 19½" screen aligns with a 48" datum from the floor.

Product Details

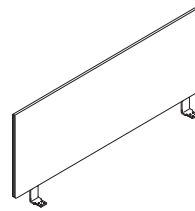

Universal privacy screens are tackable and available in 13½"H and 19½"H, and have widths from 24"W to 96"W.

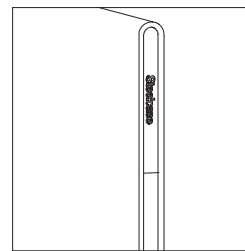

The edge of the screen is comprised of two different materials. The upper segment is merle plastic. The lower portion is PET which can be specified in medium heather grey to provide contrast or dark heather grey for a uniform visual.

The screen may be used on ¾"-1½" thick worksurfaces.

The width of the screen can be equal to or less than the width of the worksurface to which it will attach. Some restrictions apply due to location of worksurface legs and supports.

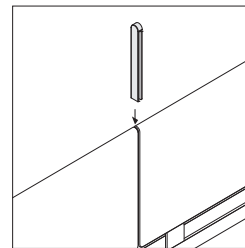

When fabric screens are placed directly adjacent to each other, a small aligner can be placed in between the screens at the top to connect them for planar alignment. Aligners are ordered separately in packages of 10.

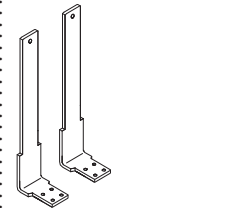
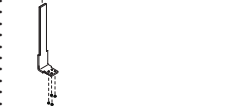
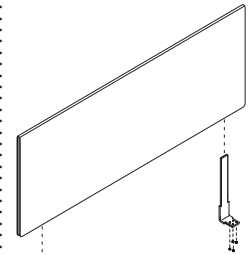

Brackets are included with screens. Two brackets are used on all screens.

Universal privacy screen slides onto brackets.

Surface Materials

Screen

- Fabric
- See *Surface Materials*, page 668.

Edge (upper segment)

- 7360 Merle

Edge (lower segment)

- P630 Medium Heather Grey PET
- P631 Dark Heather Grey PET

Brackets

- 4799 Platinum
- 7241 Textured Arctic White
- 7360 Textured Merle

Sarto Privacy/Modesty Screens

Sarto privacy/modesty screen provides a light scale boundary element for height adjustable desks and fixed worksurfaces. It can be used with Ology, Migration SE, Migration, Elective Elements, universal tables, and universal panel-mount worksurfaces.

► Specifying, page 566

Sarto privacy/modesty screens are available in overall heights from 24" to 30", with a privacy height option to provide varying levels of privacy and modesty.

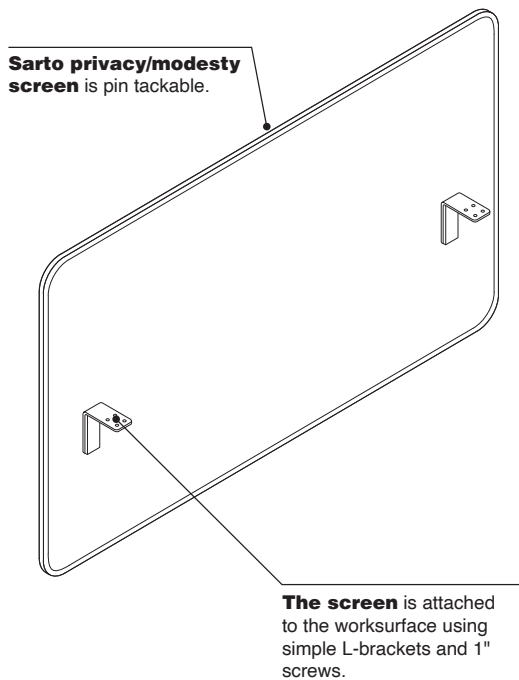

Actual Dimensions	
Width	23"-70"
Height	24"-30"
Thickness	9/16"

Product Details

The screen may be used on 3/4"-1 1/2" thick worksurfaces.

Screens are available in modular or parametric sizes.

The width of the screen can be equal to or less than the width of the work surface to which it will attach. Some restrictions apply due to location of work surface legs and supports.

Weight of screens are calculated as follows:
Screen: 0.0044 lb per inch²
Bracket: 0.2 lb per bracket.

Application Topics

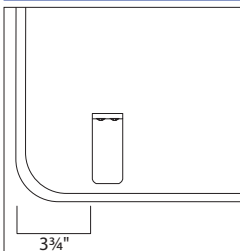

Sarto privacy/modesty screen mounts to work surfaces using simple L-brackets and screws. The brackets are positioned 3 3/4" in from each side of the screen. Two L-brackets are included with screens narrower than 60"W. Three or four L-brackets are included on screens 60"W and wider.

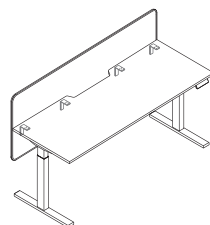

Worksurface type is available for screens 60" wide or wider, and allows the Sarto privacy/modesty screen to mount to a scalloped work surface (for example Bivi Height-Adjustable Desk).

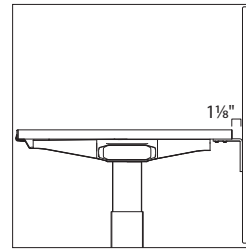

Screen can be mounted to the back edge of the work surface with a 1 1/8" cord drop or flush with no cord drop.

Screens 36"W and narrower can be mounted as side screens, and are always mounted flush to the edge of the work surface. This application grows the footprint of the workstation by 9/16" per screen.

Screens are specified with a privacy height above the work surface. A 1" thick work surface is assumed. This privacy height sets the position of the brackets and cannot be changed in the field.

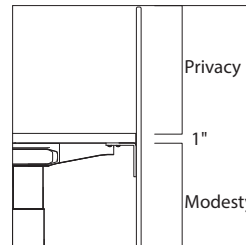

Screens are specified by first selecting an overall screen height (24"-30"), then specifying a privacy height. Privacy height is measured from the top of the screen to the top of the work surface. Allowable privacy height selection changes based on the specified overall height.

All privacy heights allow a height adjustable desk to be lowered to the lowest position (22") while preserving pinch point gap.

To match screens

ordered on or before June 20, 2021, please consult the following information to determine proper privacy height.

- 24"H Screen, Privacy/Modesty Configuration – Privacy Height = 13 1/2"
- 24"H Screen, Privacy Configuration – Privacy Height = 16 1/2"
- 30"H Screen, Privacy Configuration – Privacy Height = 22 1/2"

Sarto privacy/modesty screens can be used with universal work surfaces and tables where surface supports and leg brackets are not in same location of the screen L-bracket attachment points.

- Example 1—Worksurfaces supported by a panel side bracket or cantilever can accept privacy/modesty screen placed 6" in from end with these brackets.
- Example 2—Tables with double elliptical post C-legs can accept screens 6" shorter than total table width but not same width.

Privacy/modesty screens can also be used with Elective Elements surfaces with some restrictions when combined with gate leg or the Elective Elements adjustable-height leg.

Privacy/modesty screens must never be wider than the surface to which they are attached.
Tip: It is recommended that CET SmartTools planning aid be used to ensure proper application of screen to worksurface or tables.

Surface Materials

Screen

- Fabric
- See *Surface Materials*, page 668.

Brackets

- 7360 Merle

Sarto Privacy Screens

Sarto privacy screens provide a light scale boundary and privacy element for height-adjustable desks and fixed workspaces. It can be used with Ology, Migration SE, Migration, Elective Elements, universal workspaces, and TS Series workspaces.
 ▶ Specifying, page 568

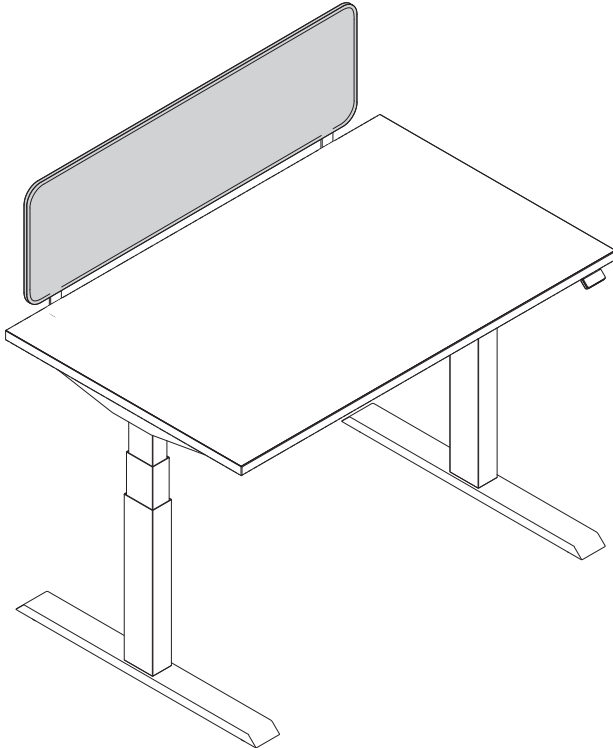

Product Details

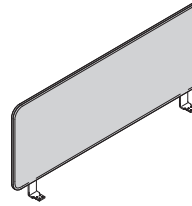

Sarto privacy screens are tackable. They are available in four modular heights, 13½"H, 19½"H, 23½"H, and 35½"H, and have widths ranging from 24"W to 96"W. Screens can also be specified parametrically.

The screen may be used on ¾"-1½" thick workspaces.

The width of the screen can be equal to or less than the width of the workspace to which it will attach. Some restrictions apply due to location of workspace legs and supports.

Tip: It is recommended that CET SmartTools planning aid be used to ensure proper application of screen to workspace or tables.

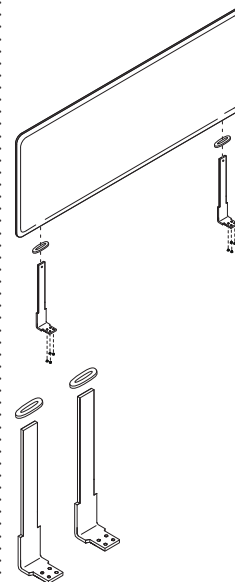

Brackets and hard stops are included with screens. Screens narrower than 60"W use two brackets, while screens 60"W and larger utilize three brackets. The third bracket is centered on the width of the screen.

Offset brackets are included with 29"W screens, to help maintain appropriate pinch points between the screen and adjacent objects. Side screen option is available for screens 36"W and narrower.

Sarto privacy screen slides onto brackets.

Alignment brackets are available to help eliminate gapping and misalignment between back and side screens. Alignment brackets are available as their own style (**PSCB**).

Weight of screens are calculated as follows:
 Screen: 0.0044 lb per inch²
 Bracket: 1.2 lb per bracket.

Surface Materials

Screen

- Fabric
- ▶ See *Surface Materials*, page 668.

Brackets and hard stops

- 7360 Merle

Actual Dimensions

Screen Height	12½"-34½"
Overall Height	13½"-35½"
Width	24"-96"

Tip: Overall height is measured from top of mounting surface to the top of the screen.

Divisio Side Screen

Divisio side screen is magnetic and provides a territorial boundary between users. The user-movable functionality allows users to decide when and where they need additional privacy. The screens may be used on any 3/4"- to 1 1/2"-thick worksurface.

► Specifying, page 571

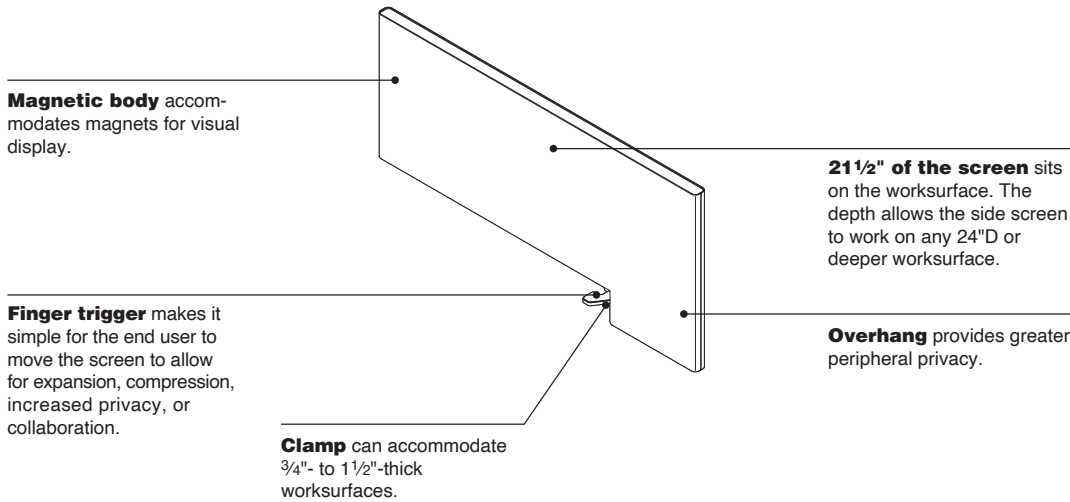

Product Details

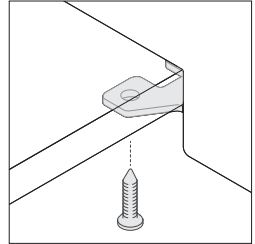

Divisio side screen can be made more permanent by adding two screws through the clamp. For 3/4" thick worksurfaces and FrameOne, a #10 x 3/4" countersunk screw is recommended. For worksurfaces over 3/4" thick, a #10 x 7/8" countersunk wood screw is recommended.

Actual Dimensions

Depth	29 1/2" (total), 21 1/2" (sits on worksurface)
Width	1 1/4"
Height	14 1/4" (total), 11 5/8" (above worksurface)



Understanding Universal Tables

Statement of Line	244
--------------------------	------------

Product Details

Universal Tables	248
Bases for Universal Tables	251
Legs for Universal Tables	252

Application Topics

Table and Base Combinations	254
Table and Leg Combinations	255
Table Leg Positions	256

Statement of Line

All table sizes and shapes are available in High-Pressure Laminate with 3 mm edge. Most sizes and shapes are also available in wood veneer with square edge. See Specifying pages for details.

Table dimensions shown apply to both wood veneer and High-Pressure Laminate versions of each table.

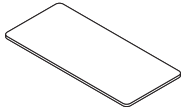

Understanding
 ▶ Page 248
 Specifying
 ▶ Page 580

Straight Tables

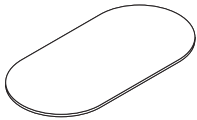
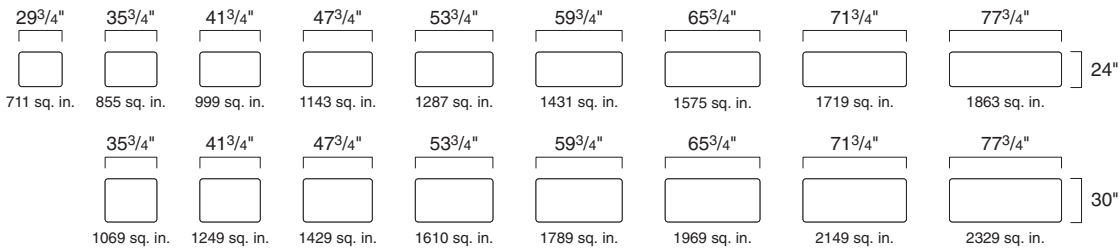

Understanding
 ▶ Page 248
 Specifying
 ▶ Page 582

Capsule Tables

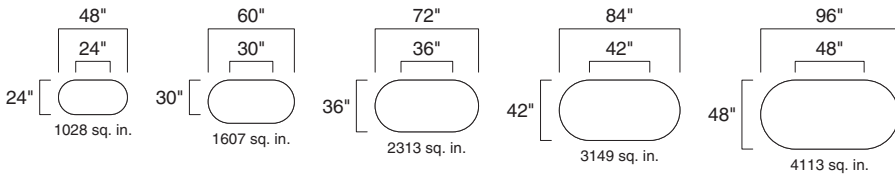

Tip: Wood veneer capsule tables are available in 72"W, 84"W, and 96"W only.



Understanding
 ▶ Page 248
 Specifying
 ▶ Page 583

Spanner Tables

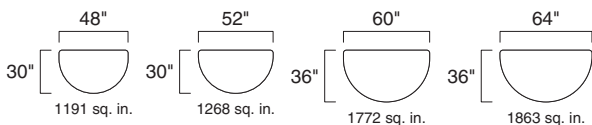



Understanding
▶ Page 248
Specifying
▶ Page 584

Peninsula Table

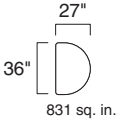

Understanding
▶ Page 248
Specifying
▶ Page 585



Understanding
▶ Page 248
Specifying
▶ Page 586

Tapered Peninsula Tables

Round Tables

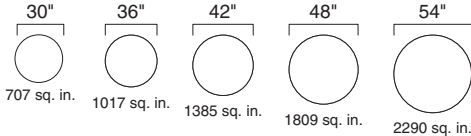
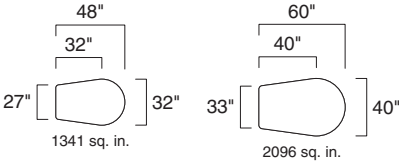

Understanding
▶ Page 248
Specifying
▶ Page 587

Square Tables

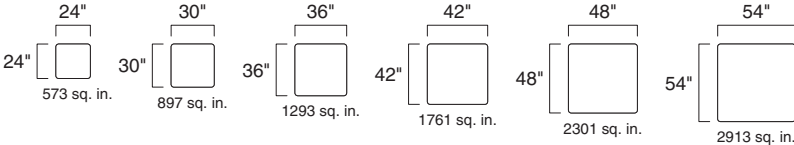

Tip: Wood veneer square tables are available in 30"W, 42"W, 48"W, and 54"W only.

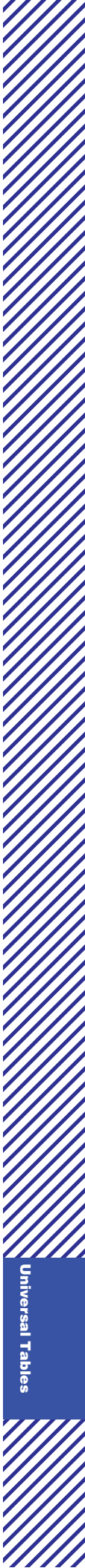

Statement of Line, continued

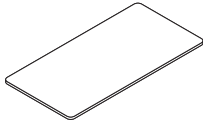

Understanding
 ▶ Page 248
 Specifying
 ▶ Page 588

Rectangle Tables

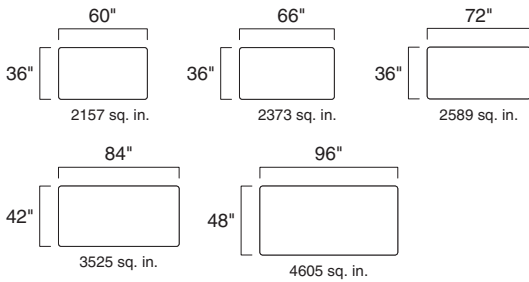

Understanding
 ▶ Page 248
 Specifying
 ▶ Page 589

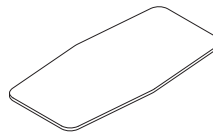

Understanding
 ▶ Page 248
 Specifying
 ▶ Page 590

Oval Tables

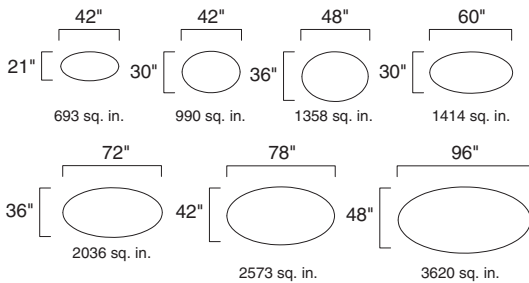

Tip: Oval tables are available in 3 mm edge High-Pressure Laminate only.

Hex Conference Tables

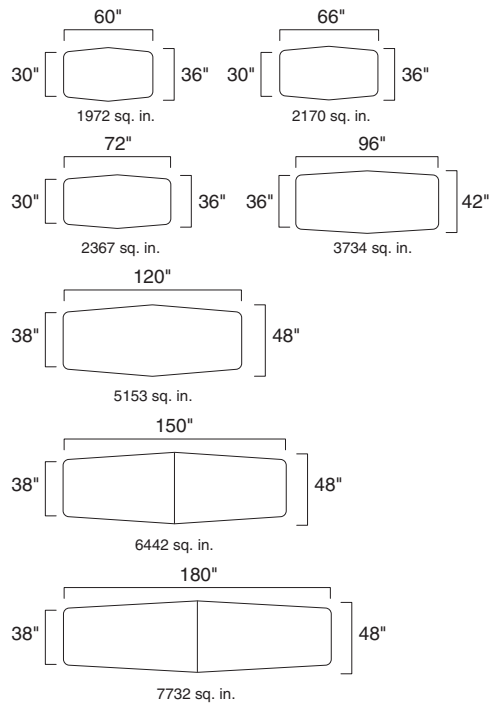

Tip: Hex conference tables are available in 3 mm edge High-Pressure Laminate only.

Bases for Universal Tables

Understanding
 ▶ Page 251
 Specifying
 ▶ Page 591

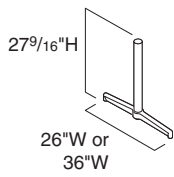

T-Base

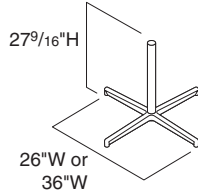

X-Base

Legs for Universal Tables

Understanding
 ▶ Page 252
 Specifying
 ▶ Page 592

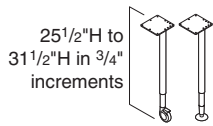

**Adjustable-Height
 Legs with Casters
 or Glides**

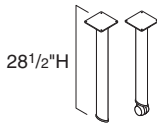

**Post Legs with
 Casters or Glides**

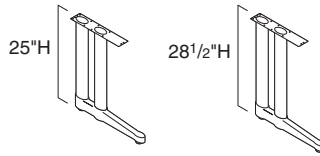

Double Post C-Legs

Tip: Height dimensions include the thickness of a table.

Universal Tables

Universal tables can be used in a variety of individual and team settings.
 ▶ Specifying tables, page 580

Table top has a wood core with a High-Pressure Laminate or wood veneer surface and is 1³/₁₆" thick.

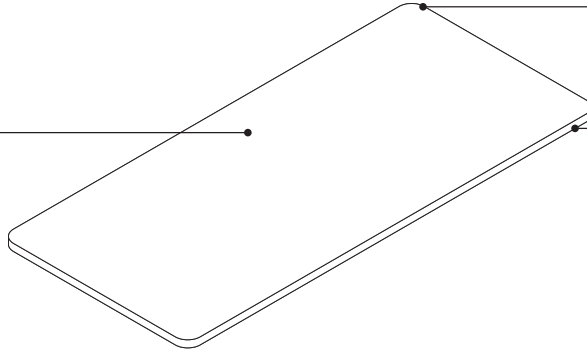

Radius corner eliminates sharp edges and is appropriate for freestanding, mobile furniture.

Edge profile is continuous around all edges of the table.

Product Details

High-Pressure Laminate Tables

Continuous edge profile is available in two shapes.

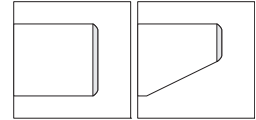

3 mm edge profile Knife edge profile

PVC-free, 3 mm edge profiles are a proprietary polyolefin blend for all solid colors and seven woodgrain finishes. See surface material listing in this book for specific PVC-free availability.

Knife edge with 3 mm user edge is available on straight and tapered systems worksurfaces and on round tables.

Edge profile finishes are specified separately from laminate color.

Wood Veneer Tables

Edges of worksurfaces are available in square (3 mm) profile.

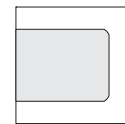

Square (3 mm) edge profile

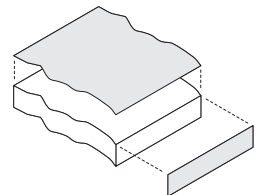

Square (3 mm) edge profile is achieved by adding wood veneer surfaces to table core. This technique can be applied to tables that are straight or curved.

Connections

Universal tables are supported by bases or legs, which are ordered separately and installed in the field.

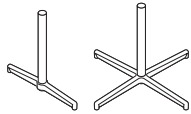

Use the Table and Base Combinations matrix to determine the type and number of bases you need to order for the tables you choose.

Tip: Not all sizes and shapes of tables can be supported by bases.

▶ Page 254

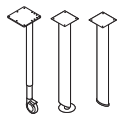

Use the Table and Legs Combinations matrix to determine the type and number of legs you need to order for the table you choose.

Tip: Not all sizes and shapes of tables can be supported by legs.

▶ Page 254

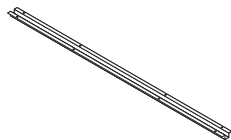

Reinforcing channels are available to support tables that are wider than 60"W and supported by legs. When installed, the channels add 1" below the table. Channels are available as an option on larger tables and are field installed. Select the reinforcing channel option if the table will be supported by legs. Channels are not required if the table is 96" or smaller and will be supported by T- or X-bases. Channels are required and are always included with tables 120" and larger.

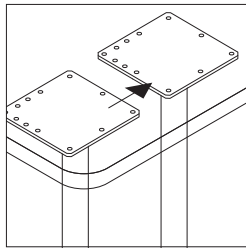

Underside of table has inset locations that support slip-fit and nesting applications.

▶ See *Table Leg Positions*, page 256.

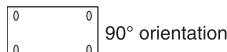

90° orientation

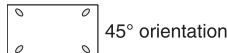

45° orientation

Legs installed in a 90° orientation allow for greater storage and kneespace below the table.

45° leg orientation is a preferred aesthetic for many customers.

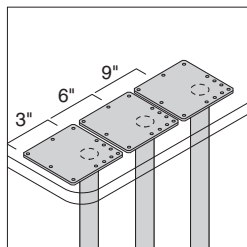

Legs may be installed inset from the edge of the table to accommodate slip-fit planning. Amount of available space (3", 6", or 9") is measured from the edge of the table to the edge of the leg. Amount of slip-fit varies by table shape and size.

▶ See *Table Leg Positions*, page 256.

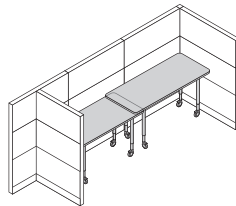

Slip-fit planning allows workstation footprint to expand or decrease, and is ideal for off-module applications.

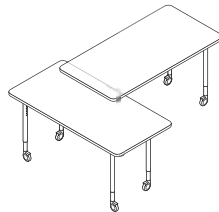
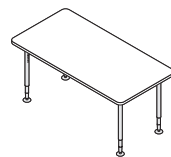
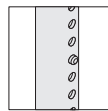
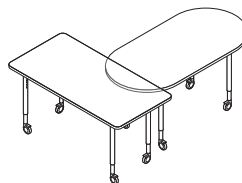

Table with 28½"H legs installed at 6" or 9" inset can slip over adjacent tables that are supported with 26"H legs.



Adjustable-height legs adjust 25½"H to 31½"H in ¾" increments. Legs can be used to support the table in a standard height or nesting application.



26"H legs allow tables to nest underneath an adjacent table with 28½"H legs or a panel-mounted worksurface.

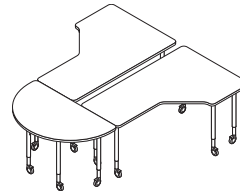

Spanner table enables conferencing at the end of two tables that are placed back-to-back.

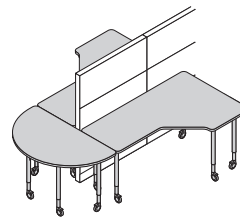

52"W or 64"W spanners should be used when tables are separated by a panel.

Surface Materials

High-Pressure Laminate Tables

- Laminate
- ▶ See *Surface Materials Reference Manual*.
- Open Line laminate (option)
- A program including non-Steelcase laminates which are suitable for use on Steelcase products.
- ▶ See *Surface Materials Reference Manual*.

- **3 mm profile**
- Plastic

Wood Veneer Tables

- Wood veneer (standard)
- Customiz stain (option)
- Full-fill finish (option)

Square (3 mm) edge profile

- Wood veneer to match table

Application Topics

Table Fit in Panel Environments:

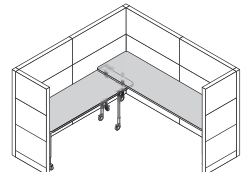
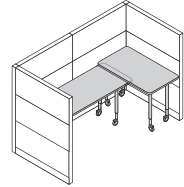

Dimensions on straight tables are ¼" less than nominal dimension. This allows for an easy fit of freestanding tables in panel-wrapped environments and allows tables to move in and out of the area with ease.

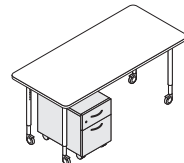

Mobile pedestals up to 24½"H will fit under 26"H tables without reinforcing channels.

Mobile pedestals up to 27"H will fit under 28½"H tables without reinforcing channels.

Tables with reinforcing channel will reduce the available space by 1".

Table and Base Combinations

▶ Page 254

Table and Leg Combinations

▶ Page 255

Table Leg Positions

▶ Page 256

Universal Tables, continued

Shipping

Palletizing streamlines unloading and staging of worksurfaces. Identical worksurfaces ordered on the same line item are packed on pallets containing 5-50 worksurfaces depending on worksurface size. Remaining worksurfaces are packed individually in cartons. If palletizing is not desired, order in quantities of four or less per line item. For maximum unload efficiency, utilize pallet handling equipment at job site whenever possible. Wood veneer worksurfaces cannot be palletized.

Hex conference tables 150"W or larger are shipped in two pieces. Tight-joint fasteners are supplied for proper assembly.

Bases for Universal Tables

Pedestal-base tables

fill a variety of needs for conference and work tables in general offices, institutions, and educational work spaces. Tables and bases are ordered separately.

► Specifying, page 591

Adjustable leveling glides allow tables to remain level when installed on uneven floors.

Column support includes a cylindrical steel column and a base with feet.

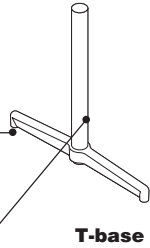

T-base

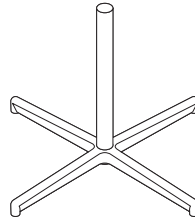

X-base

Product Details

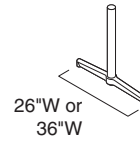

26"W or 36"W

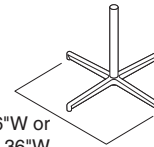

26"W or 36"W

Bases are available 26"W and 36"W and are 27⁹/₁₆"H.

Surface Materials

Column support

- Paint (standard)
- 8046 Polished Aluminum

Base

- Paint (standard)
- 8046 Polished Aluminum

Application Topics

Table and Base Combinations

► Page 254

Shipping

Bases are shipped knocked down (K.D.) and will require assembly.

Legs for Universal Tables

Legs attach to a table to make it freestanding.
 ▶ Specifying, page 592

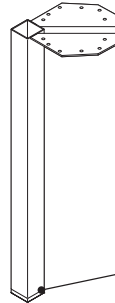

Post legs are available with non-locking casters or glides.

Alignment tab helps installers locate proper leg position under the table.

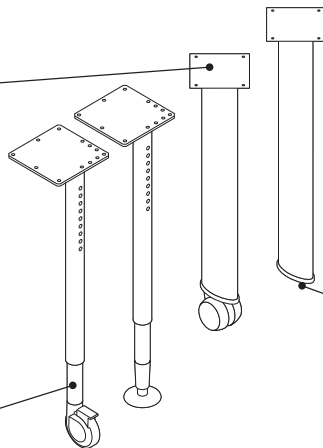

Leveling glides, included, allow table height to be adjusted on uneven floors.

Adjustable-height leg adjusts from 25 1/2"H to 31 1/2"H in 3/4" increments.

Actual Dimensions

	Adjustable-height leg	Post leg
Height* (standard)	25 1/2"-31 1/2"	28 1/2"
Glide range, for legs equipped with glides	3/4"	3/4"

*Height dimensions include the thickness of a table.

Product Details

Legs support tables at 28½"H overall, including table thickness.

Table legs are ordered separately and installed on site.

▶ See *Table and Leg Combinations*, page 255.

Table legs are non-handed to accommodate left- and right-hand applications.

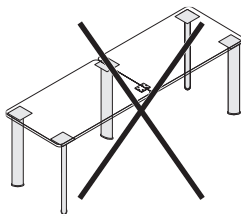
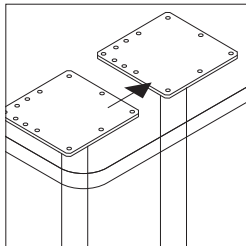

Table legs cannot be used in a shared application with two tables. Radius corners do not provide enough attachment space for leg plate. When a shared leg application is required, order Universal Systems Worksurfaces.



Single post legs can only be installed in a 45° orientation.

▶ See *Table Leg Positions*, page 256.



90° orientation



45° orientation

Legs installed in a 90° orientation allow for greater storage and kneespace below the worksurface.

45° leg orientation is a preferred aesthetic for many customers.

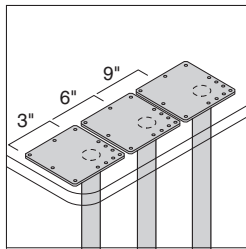

Legs may be installed inset from the edge of the worksurface to accommodate slip-fit planning. Amount of available space (3", 6", or 9") is measured from the edge of the worksurface to the edge of the leg.

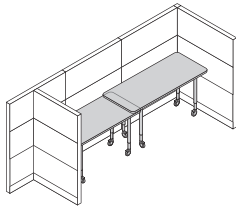

Slip-fit planning allows workstation footprint to expand or decrease, and is ideal for off-module applications.

Alignment tab corresponds to under worksurface alignment slots in tables. Alignment features ensure legs are installed in the proper 45° or 90° orientation and slip-fit position.

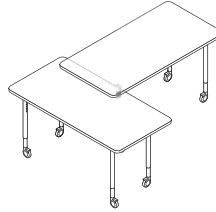
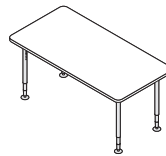
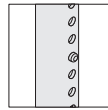
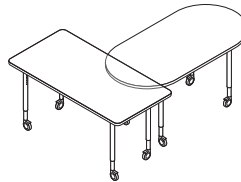

Table with 28½"H legs installed at 6" or 9" inset can slip over adjacent tables that are supported with 26"H legs.



Adjustable-height legs adjust 25½"H to 31½"H in ¾" increments. Legs can be used to support the table in a standard height or nesting application.



26"H legs allow tables to nest underneath an adjacent table with 28½"H legs or a panel-mounted worksurface.

Surface Materials

Adjustable-height legs, post, and post with caster

- Paint

Post leg caster

- Black plastic

Application Topics

























Table and Leg Combinations

▶ Page 255

Table Leg Positions

▶ Page 256

Table and Base Combinations

	26"W T-Base 	36"W T-Base 	26"W X-Base 	36"W X-Base 
Straight Tables				
24"D x 36"W			 ①	
30"D x 36"W–42"W				 ①
30"D x 48"W–78"W	 ②			
Capsule Tables				
24"D x 48"W			 ②	
30"D x 60"W 36"D x 72"W	 ②			
42"D x 84"W 48"D x 96"W		 ②		
Round Tables				
30" diameter 36" diameter			 ①	
42" diameter 48" diameter 54" diameter				 ①
Square Tables				
30"D x 30"W			 ①	
36"D x 36"W 42"D x 42"W				 ①
48"D x 48"W 54"D x 54"W		 ②		
Rectangle Tables				
36"D x 60"W 36"D x 66"W 36"D x 72"W	 ②			
42"D x 84"W 48"D x 96"W		 ②		
Oval Tables				
30"D x 42"W			 ①	
36"D x 48"W				 ①
30"D x 60"W 36"D x 72"W 42"D x 78"W	 ②			
48"D x 96"W		 ②		
Hex Conference Tables				
36"D x 60"W 36"D x 66"W 36"D x 72"W	 ②			
42"D x 96"W		 ②		
48"D x 120"W 48"D x 150"W 48"D x 180"W		 ③		

① = Number of bases to order.
Blank spaces in matrix designate table and base combinations that are not valid.

Table and Leg Combinations

Adjustable-Height Leg or Post Leg



Straight Tables	④
Round Tables	④
Square Tables	④
Rectangle Tables	④
Spanner Tables	④
Capsule Tables	④
Peninsula Tables	④
Tapered Peninsula Tables	④
Oval Tables, up to 36"D x 72"W	④

Tip: Oval tables 21"D x 42"W and 30"D x 42"W may only use legs with glides. Legs with casters may not be used on these table sizes.

Tip: Hex conference tables and oval tables 42"D x 78"W and larger, can only be supported with T-bases.

① = Number of legs to order.
Blank spaces in matrix designate table and leg combinations that are not valid.

Table Leg Positions

Table leg positions

allow for slip-fit and nesting capabilities. Both 45° and 90° angled leg positions are available on most tables. However, certain tables accommodate either 45° or 90° angled positions only. Leg positions on the underside of tables are shown at right.

Legs installed in positions 1, 2, or 3 will vary in their distance from the worksurface edge:

Position 1 is 3" from edge
Position 2 is 6" from edge
Position 3 is 9" from edge
Tip: Positions 2 and 3 are not available on every table.

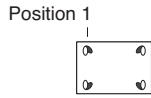

Straight Table
24"D x 30"W

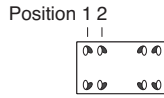

Straight Table
24"D x 36"W
30"D x 36"W
30"D x 42"W

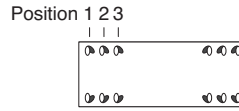

Straight Table
24"D x 48"W 30"D x 48"W
24"D x 54"W 30"D x 54"W
24"D x 60"W 30"D x 60"W
24"D x 66"W 30"D x 66"W
24"D x 72"W 30"D x 72"W
24"D x 78"W 30"D x 78"W

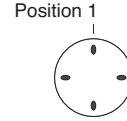

Round Table
30" Diameter
36" Diameter
42" Diameter
48" Diameter

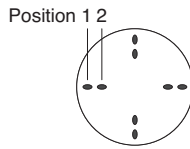

Round Table
54" Diameter

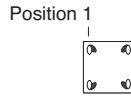

Square Table
24"D x 24"W
30"D x 30"W

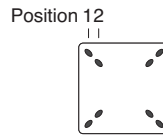

Square Table
36"D x 36"W
42"D x 42"W
48"D x 48"W
54"D x 54"W

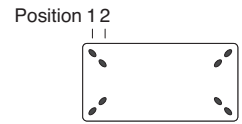

Rectangle Table

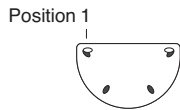

Spanner Table

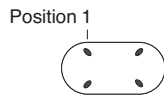

Capsule Table
24"D x 48"W
30"D x 60"W

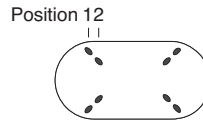

Capsule Table
36"D x 72"W
42"D x 84"W
48"D x 96"W

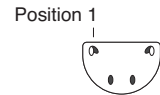

Peninsula Table

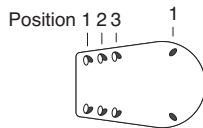

Tapered Peninsula Table

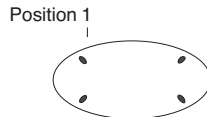

Oval Table
21"D x 42"W 30"D x 60"W
30"D x 42"W 36"D x 72"W
36"D x 48"W

Legend

- ⊕ = Both 45° and 90°
- ⊙ = Either 45° or 90°

Understanding Answer Monitor Mount Integration



Statement of Line

258



Product Details

Answer Monitor Mount

260

Statement of Line

media:scape Integration

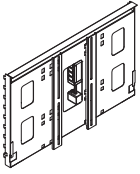

Understanding
▶ Page 260
Specifying
▶ Page 596

Answer Monitor Mount

Answer Monitor Mount

Answer monitor mount attaches to Answer panels. It provides a clean aesthetic and can be used to project information in various applications. It is not used in conjunction with media:scape.
▶ Specifying, page 596

Monitor attachment brackets are used to attach monitor display to monitor mount.

Power strip is included in the monitor mount assembly, providing four receptacles.

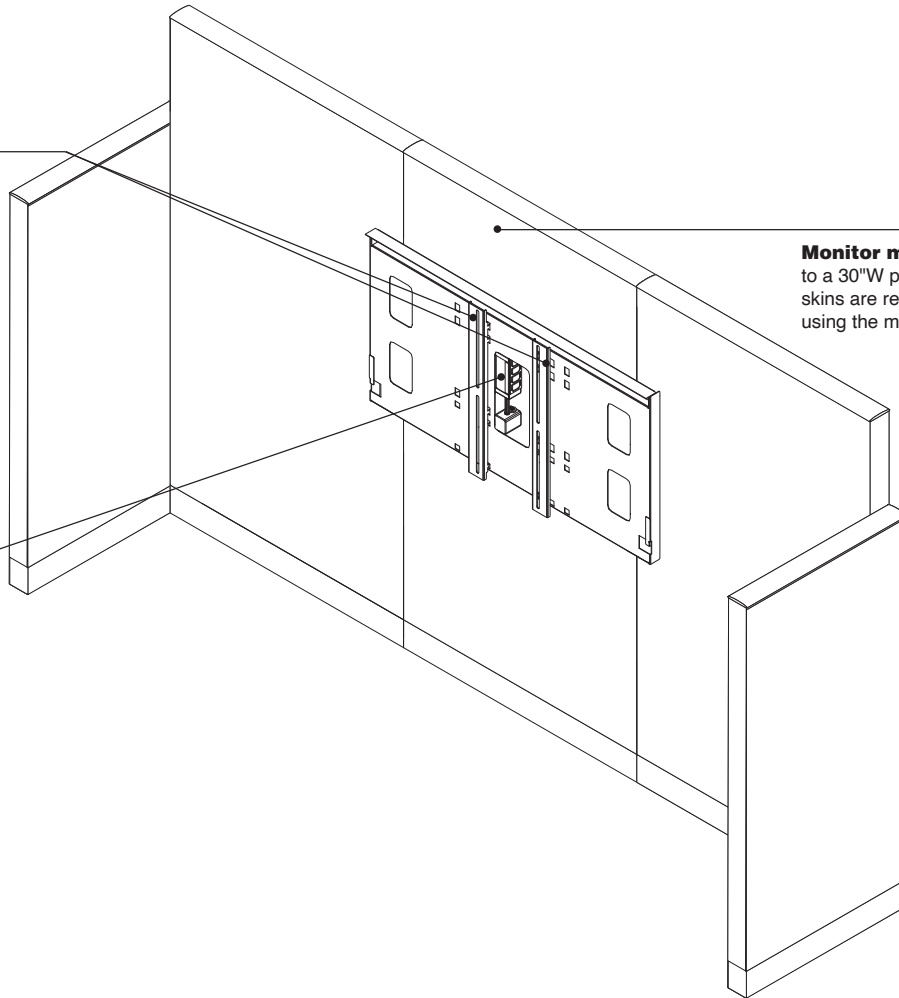

Monitor mount connects to a 30"W panel only. Fabric skins are required when using the monitor mount.

Product Details

The monitor mount will affix to a 30" wide panel only. When using the monitor mount, fabric skins must be located behind monitor mount.

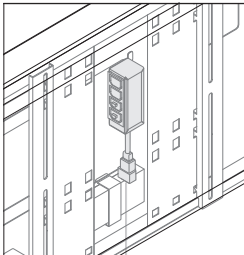

Power strip cord is routed in the interior of the panel and exits under the base trim. Plugging into the base is recommended. Monitor mount cord length is 10'.

Power strip included with monitor mount has IEC C13 receptacles.

Tip: If the monitor has a NEMA plug, a C14 to NEMA adapter will be required. C14 to NEMA adapters are commonly available. A C14 to NEMA adapter is also available as service part **11M0465SR**.

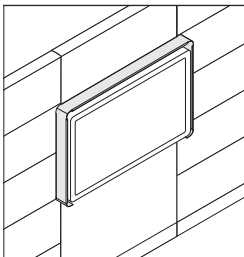

Answer monitor mount can accommodate 40" and 42" monitors or a maximum of 75 pounds.

Application Topics

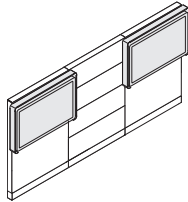

It is possible to place two monitors on an Answer panel run. Monitors will overhang adjacent panels.

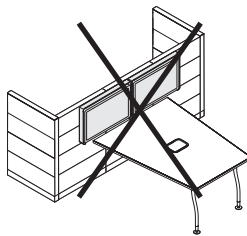

Single monitors cannot be placed directly adjacent to one another. It is recommended to place a 30" panel between the two monitors.

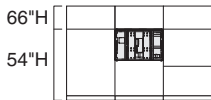

Monitor mount can be used on panels 54"H and taller. Maximum height that the monitor mount can be installed at is 66"H. Minimum height that the monitor can be installed at is 24"H.

A horizontal seam between two skins cannot fall directly behind the monitor mount.

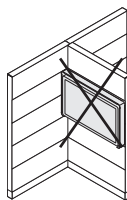

Monitor mount brackets must connect into in-line junctions. They cannot connect to L, T, or X junctions.

Stability Guidelines

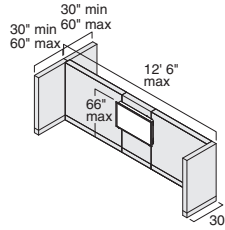

For runs over 8' and up to 12'6", must use at least a 30"W return panel when using monitor mount or media:scape integration. The monitor mount is not to exceed 66"H.

Surface Materials

Monitor mount
• 7237 Slate



Understanding Counterweights

Counterweights	264
Counterweight Requirements for Storage Products	265

Counterweights

Counterweight packages are required to ensure product stability and are ordered as an option or separately. Product specification pages indicate the correct counterweight package for each style number and any exceptions where counterweights are not required.
 ▶ See *Counterweight Requirements for Storage Products*, page 265.

Counterweight Packages for Lateral Files and Cabinets

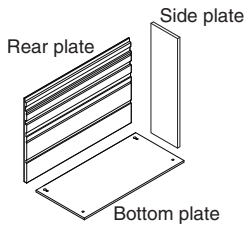

▶ Specifying, page 660

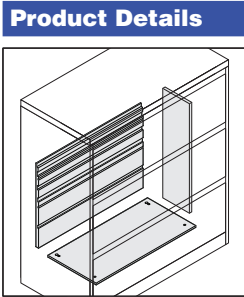

Surface Materials

Counterweight plates
 • Black only

Actual Dimensions

Depth 3¹/₈" or 2³/₈"
Width 25¹/₂"
Height 18"

Counterweight Package for Towers

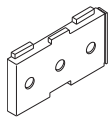

▶ Specifying, page 660

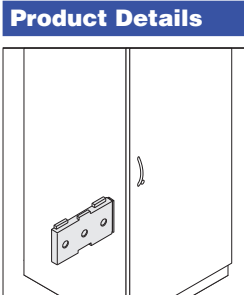

Surface Materials

Counterweight
 • Black only

Actual Dimensions

Depth 1¹/₄"
Width 12"
Height 1¹/₄"

Counterweight Packages for Bookcases

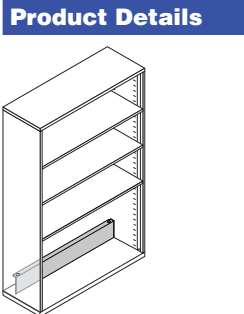
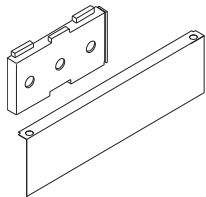

Counterweight packages attach to the inside of the bottom shelf. A cover is included to conceal the counterweight.

Surface Materials

Counterweight
 • Black
Cover
 • Paint

Actual Dimensions

Counterweight
 Depth 1¹/₄"
 Width 19", 25", 31", or 37"
 Height 1¹/₄"
Cover
 Depth 1³/₈"
 Width 23³/₄", 29³/₄", 35³/₄", 41³/₄"
 Height 1¹/₄"

Counterweight Requirements for Storage Products



WARNING

Follow these requirements to reduce the risk of storage products tipping and causing injury.

Requirements for Lateral Files, Towers, Cabinets, and Bookcases Applications

Specification Information						
• Dimensions		W	H	• Counterweight Package	• Style Number	
D						
Flush	Proud					
Steel	Steel/					
Front	Wood					
Three 12"H Drawers						
18"	18 ⁷ / ₈ "	30"	40"	Package 3	RLF18303	
18"	18 ⁷ / ₈ "	36"	40"	Package 3	RLF18363	
18"	18 ⁷ / ₈ "	42"	40"	Package 3	RLF18423	
23 ¹ / ₈ "	24"	30"	40"	Package 2	RLF24303	
23 ¹ / ₈ "	24"	36"	40"	Package 2	RLF24363	

Product specification pages indicate proper counterweight package for each style number.

Specification Information						
• Dimensions		W	H	• Counterweight Package	• Style Number	
D						
Flush	Proud					
Steel	Steel/					
Front	Wood					
	Front					
65¹/₂"H Tower with Door Hinged on Left, continued						
Partition with Coat Rod, Two Adjustable Shelves, One Fixed Shelf, and						
23 ¹ / ₈ "	24"	24"	65 ¹ / ₂ "	Not required	RFF24245LW	

If a counterweight is not required in any condition for a particular style number, the product specification page will indicate not required.

Counterweight Requirements for Storage Products, continued

Requirements for Freestanding Applications

Counterweights are required as shown in the product specification pages unless any of the following conditions are met:

1. Counterweights are not required for lateral files, towers, cabinets, and bookcases anchored to the floor.

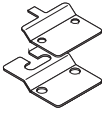

Floor anchor bracket (for TS Series Storage and Universal Storage with 3" base) secures lateral files, towers, cabinets, or bookcases to the floor for stability or to reduce the risk of hazards during earthquakes in seismic zones. Four bracket packages are required for each cabinet.

Note: Local seismic requirements vary. Compliance with local code requirements is the responsibility of the customer or their authorized agent. For a California Office of Statewide Health Planning and Development (OSHDP) approved anchor bracket, contact Steelcase Specials. Tip: Anchor bracket cannot be used with pedestals.



Floor anchor brackets for Universal with FrameOne foot secure lateral files and towers to the floor for stability or in seismic zones to reduce the risk of hazards during earthquakes.

Note: Local seismic requirements vary. Compliance with local code requirements is the responsibility of the customer or their authorized agent.

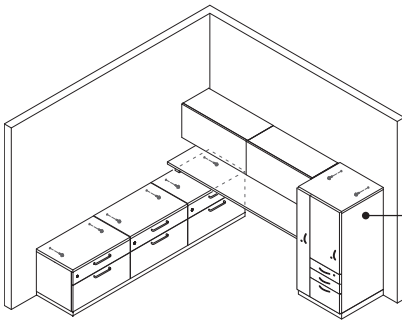

Wall Anchors

2. Counterweights are not required for lateral files, towers, cabinets, and bookcases anchored to the wall.

For wall anchoring of lateral files, towers, cabinets and bookcases, consult with the building's designated design professional (architect or engineer) and work with local codes authorities for approvals to ensure adequate support when product is fully loaded.

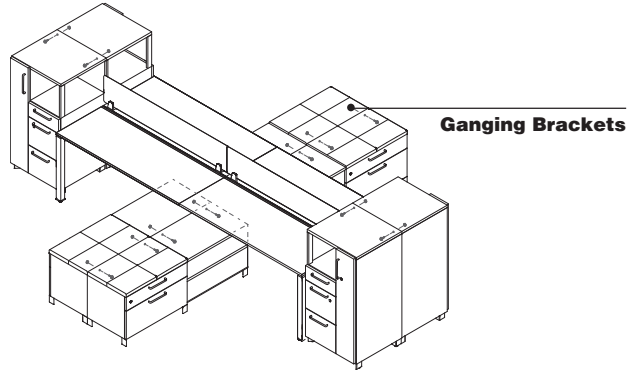

Ganging Brackets

3. Counterweights are not required for lateral files, towers, cabinets, and bookcases ganged back-to-back with ganging hardware.

TS Series towers which do not include ganging hardware, order 8425808SR from Service Parts.

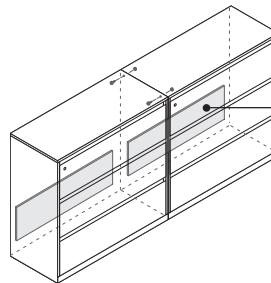

Counterweights

Units ganged side-by-side **require** counterweights.

Requirements for Panel Applications

Panel stability guidelines must be met prior to determining counterweight requirements.

► See *Panel Stability Guidelines* in the appropriate panel specification guide. (Storage may support panel stability)

Counterweights are required as shown in the product specification pages unless any of the following conditions are met:

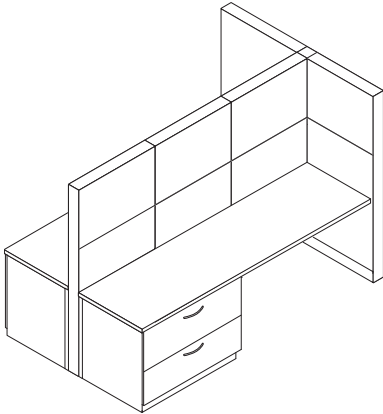

1. Counterweights are not required for Two Drawer lateral files installed right below a work surface attached to the panel system when the application is mirrored back-to-back (a two-pack minimum).

TS Series underworksurface lateral files are only intended for use under a panel-mounted work surface and cannot be used as freestanding.

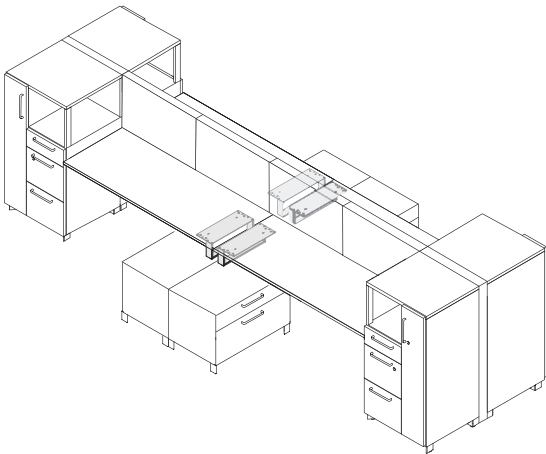

2. Counterweights are not required for One-High and 1.5-High lateral files and cabinets used with an intermediate support, when the application is mirrored back-to-back (a two-pack minimum).

Note: This includes storage either perpendicular or parallel to the panel.

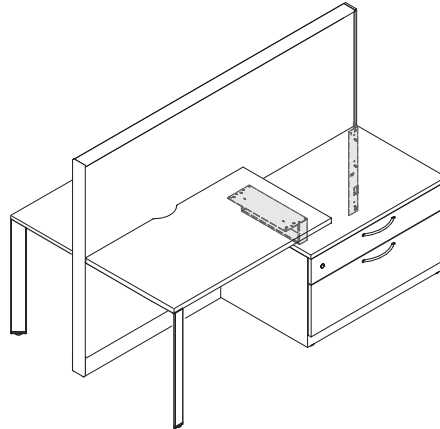

3. Counterweights are not required for One-High, 1.5-High, and Two Drawer lateral files and cabinets used with a storage-to-panel bracket to support the panel run if the application is mirrored back-to-back (a two-pack minimum) and the panel run is equal to or greater than 6'.

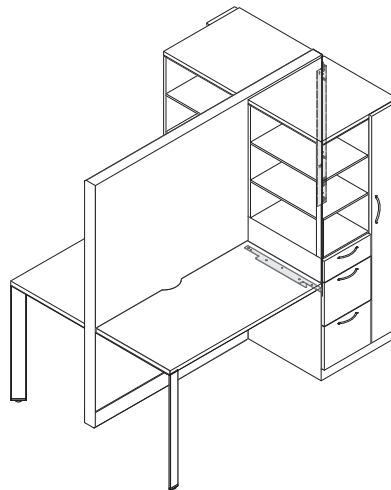

4. Counterweights are not required for towers used with a storage-to-panel connector to support the panel run, if the application is mirrored back-to-back (a two-pack minimum) and the panel is equal to or greater than 5'.

Counterweight Requirements for Storage Products, continued

Requirements for Answer Freestanding Desk Applications

Answer Freestanding Desk guidelines must be met prior to determining counterweight requirements.
▶ See *Answer Freestanding Desk Stability Guidelines* in the *Answer Freestanding Specification Guide*.

Counterweights are required as shown in the product specification pages unless any of the following conditions are met:

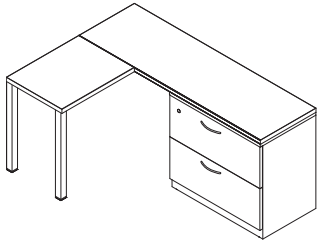

1. A counterweight is not required for a single Two Drawer lateral file attached to desks connected in an L-configuration.

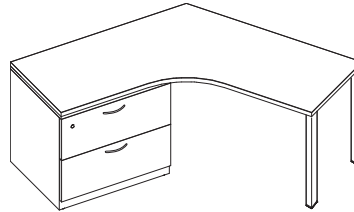

2. A counterweight is not required for a single Two Drawer lateral file attached to a desk made with corner, extended corner, or 120° corner worksurfaces.

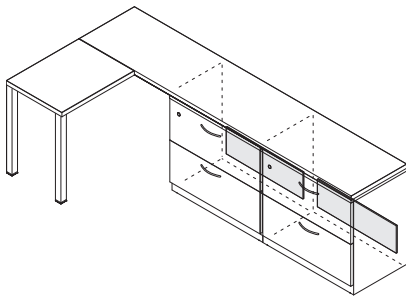

L-configurations with two or more lateral files **require** counterweights in each file.

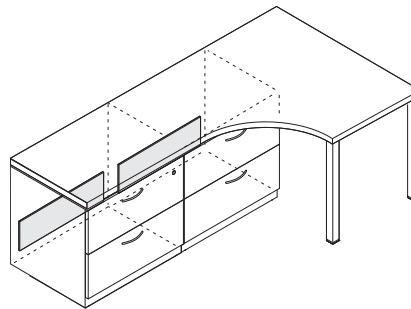

Configurations with two or more lateral files **require** counterweights in each file.

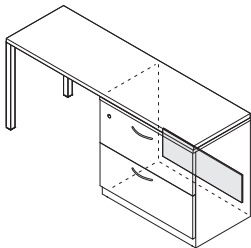

Counterweights are **required** for all lateral files in stand-alone desk or credenza applications.

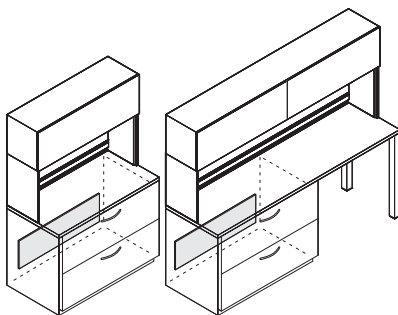

Hutch kit applications with lateral files always **require** counterweights in the lateral files.

Requirements for Pedestals in Freestanding Applications

Counterweights are required for all freestanding applications.

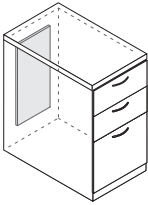

1. Universal fixed pedestals converted to freestanding pedestals require a counterweight.

Universal fixed to freestanding pedestal conversion kit includes 1/8"H steel top and counterweight package.

Fixed pedestals, converted to freestanding with a laminate or veneer top, require a counterweight.

TS Series fixed pedestals are only intended for use under a panel-mounted worksurface and cannot be converted to freestanding.

Laminate fixed pedestals can never be freestanding.

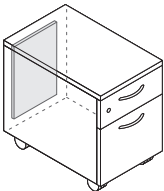

2. Mobile pedestals include counterweight as standard.

Requirements for Pedestals in Panel Applications

Panel stability guidelines must be met prior to determining counterweight requirements.

► See *Panel Stability Guidelines* in the appropriate panel specification guide.

Counterweights are required as shown in the product specification pages unless any of the following conditions are met:

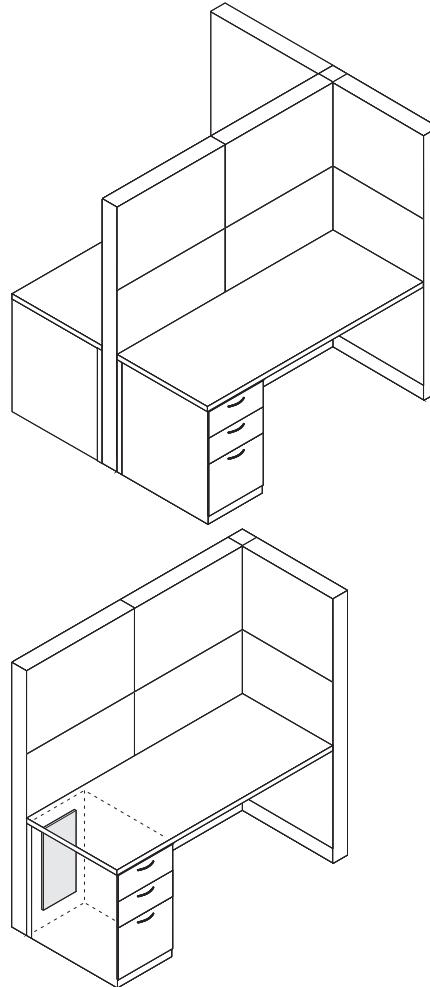

Counterweights are not required for fixed pedestals installed below a worksurface attached in a panel spine application. Single workstation applications **require** a counterweight in each pedestal.

Counterweight Requirements for Storage Products, continued

Requirements for Pedestals in Answer Freestanding Desk Applications

Answer Freestanding Desk guidelines must be met prior to determining counterweight requirements.
▶ See *Answer Freestanding Desk Stability Guidelines* in the *Answer Freestanding Specification Guide*.

Counterweights are required as shown in the product specification pages unless any of the following conditions are met:

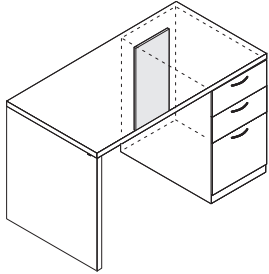

1. Single pedestal desks less than 48"W require a counterweight and an interlock. Single pedestal desks with 30"D pedestals require a counterweight and interlock.

Tip: Interlock is available as a service part for Universal pedestals, 1043575SR for box/box/file and file/file configurations.

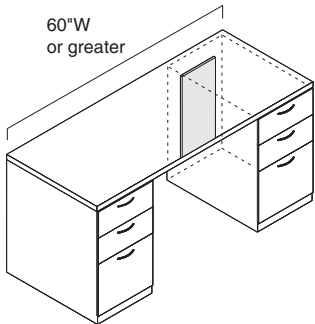

2. Double pedestal desks 60"W and wider only require one pedestal with counterweight.

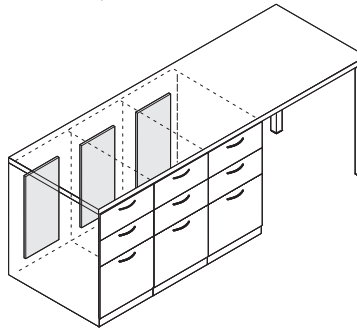
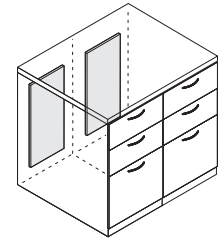
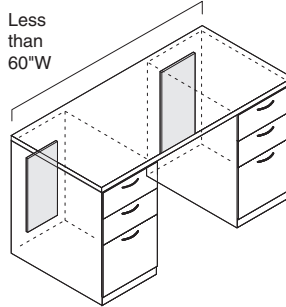

All other desk applications with multiple pedestals **require** a counterweight for each pedestal.

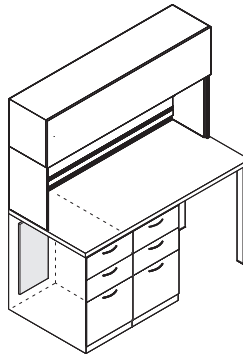
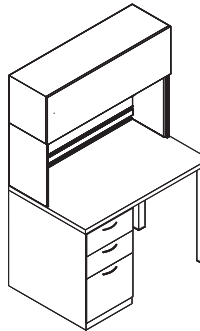

3. Counterweights are not required for a single fixed pedestal in desk with hutch kit applications. Any additional pedestals within the application **require** counterweights.

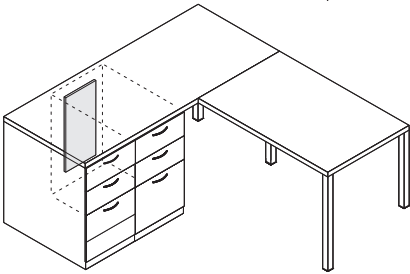
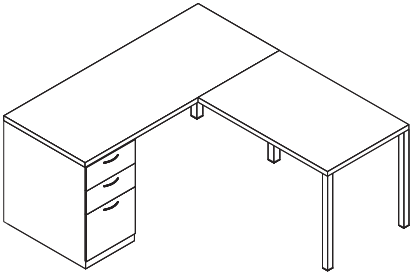
Requirements for Pedestals in Answer Freestanding Desk Applications, continued

4. A counterweight is not required for a single fixed pedestal attached to a desk attached to another worksurface in an L-configuration. Any additional pedestals within the application require counterweights.

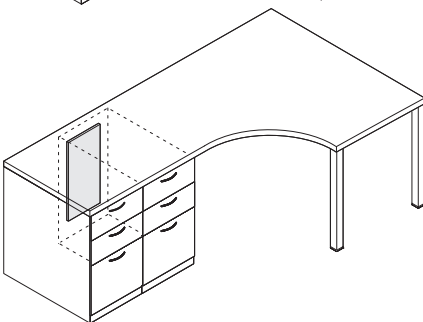
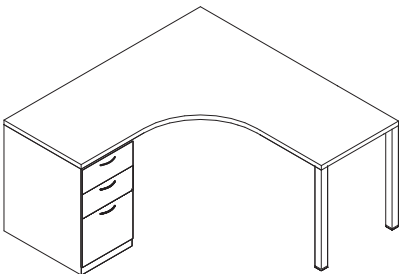

5. A counterweight is not required for a single fixed pedestal attached to desks made with corner, extended corner, or 120° corner worksurfaces. Any additional pedestals within the application require counterweights.

Understanding Universal Steel Storage Products

Statement of Line	274
--------------------------	------------

Universal Pedestals	278
Universal Sliding Door Bins	282
Universal Over the Case and In The Case Bins	286
Dimensions for Custom Field-Installed Picture Frame Door Inserts	289
Universal Shelves and Universal Personal Shelves	290
Dividers	292
Slim Shelves	293
Bracket Application Rules for Bins and Shelves	294
Application Rules for Overhead Storage on Answer and Kick Panels	296
Universal One-High, 1.5-High, and Two Drawer Lateral Files	298
Universal Towers	302
Connectors	305

Statement of Line

For the full Universal Storage offering, see *Storage Specification Guide*.

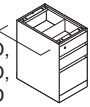

17¹/₂"D,
22⁵/₈"D,
or 28⁵/₈"D

Flush steel front

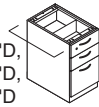

18³/₈"D,
23¹/₂"D,
or 29¹/₂"D

Proud steel, laminate,
or wood front

Understanding
▶ Page 278
Specifying
▶ Page 598



17¹/₂"D
or 22⁵/₈"D

Flush steel front

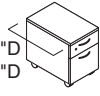

18³/₈"D
or 23¹/₂"D

Proud steel, laminate,
or wood front

Understanding
▶ Page 278
Specifying
▶ Page 602

Universal Fixed Pedestals

15"W	
25 ¹ / ₂ "H	●
27"H	●

Universal Mobile Pedestals

15"W	
21"H	●
27"H	●

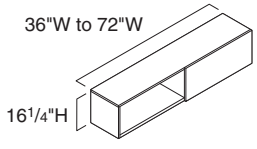

Understanding
▶ Page 282
Specifying
▶ Page 606

Universal Sliding Door Bins

For Use with Answer

	36"W	42"W	48"W	60"W	66"W	72"W
15 ³ / ₄ "D	●	●	●	●	●	●

24"W to 48"W

16¹/₄"H

Flat steel, laminate,
or wood front

60"W to 72"W

16¹/₄"H

Flat steel, laminate,
or wood front

Understanding
▶ Pages 286
Specifying
▶ Pages 608 and 610

Universal Over the Case and In the Case Bins with Flat, Laminate, and Wood Flat Fronts

For Use with Answer

	24"W	30"W	36"W	42"W	48"W	60"W	66"W	72"W
15 ³ / ₄ "D	●	●	●	●	●	●	●	●

For the full Universal Storage offering, see Storage Specification Guide.

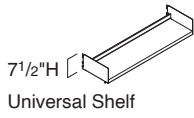

7 1/2"H
Universal Shelf

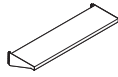

Universal Personal Shelf

Understanding
▶ Page 290
Specifying
▶ Page 613

Universal Shelves and Universal Personal Shelves

For Use with Answer

	24"W	30"W	36"W	42"W	48"W	60"W	72"W
Universal Personal Shelves 13 1/16"D	●	●	●	●	●		
Universal Shelves 14 3/4"D	●	●	●	●	●	●	●

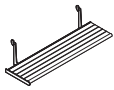

Slim Shelves

	24"W	30"W	36"W	42"W	48"W	60"W	72"W	96"W
6"D	●	●	●	●	●	●	●	●

Understanding
▶ Page 293
Specifying
▶ Page 619

Universal One-High

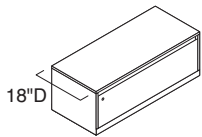

18"D
Flush steel front

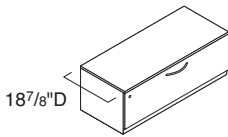

18 7/8"D
Proud steel, laminate, or wood front

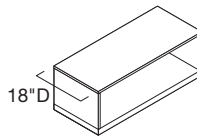

18"D
Flush steel open front

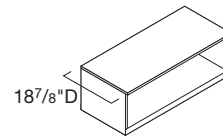

18 7/8"D
Proud steel open front

Universal 1.5-High

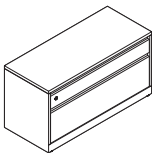

Flush steel front

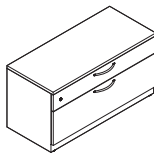

Proud steel, laminate, or wood front

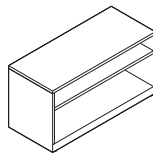

Flush steel open front

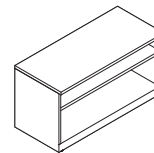

Proud steel open front

Understanding
▶ Page 298
Specifying
▶ Page 620

Universal One-High and 1.5-High Lateral Files

	30"W	36"W	42"W
One-High 16"H	●	●	●
1.5-High 22"H	●	●	●

Tip: 42"W lateral files are available 18"D and 18 7/8"D only.

Statement of Line, continued

For the full Universal Storage offering, see *Storage Specification Guide*.

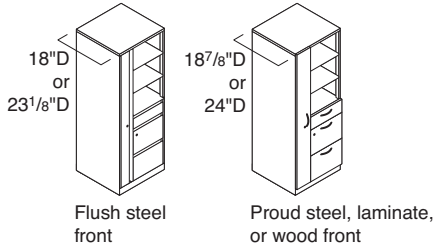

Understanding
 ▶ Page 302
 Specifying
 ▶ Page 628

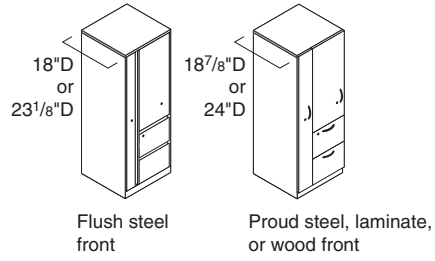

Understanding
 ▶ Page 302
 Specifying
 ▶ Page 632

Universal Open Side Towers

	24"W
47 1/2"H	●
52"H	●
65 1/2"H	●

Drawings show door hinged left.
 Units are also available with door hinged right.

Universal Dual Door Towers

	24"W
47 1/2"H	●
52"H	●
65 1/2"H	●

Drawings show door hinged left.
 Units are also available with door hinged right.

Universal Pedestals

27"H fixed pedestals

are floor-standing and can support worksurfaces at 28½"H.

- ▶ Specifying, page 598
- ▶ Specifying *Storage Accessories*, page 655

Top is open and accommodates attachment to a worksurface. Attachment hardware is included.

Lock is standard on pedestals and secures all drawers. Lock is located in the top drawer. Locks are standard factory-installed, keyed random.

- ▶ *Lock and Keying*, page 686

Leveling glides adjust to install pedestals on uneven floors. 25½"H pedestals have a 7⁄8" adjustable glide range, and 27"H pedestals have a 17⁄8" adjustable glide range.

Mobile pedestals fit under a worksurface and can be moved wherever storage is needed. They provide an auxiliary work-surface when you need more space to spread out your work.

- ▶ Specifying, page 602
- ▶ Specifying *Storage Accessories*, page 655

Finished back and sides are standard.

Four casters are hard composition and non-locking, with a full-rotation swivel mechanism. Casters are exposed at the base of box/file pedestals and concealed with the base of box/box/file and file/file pedestals.

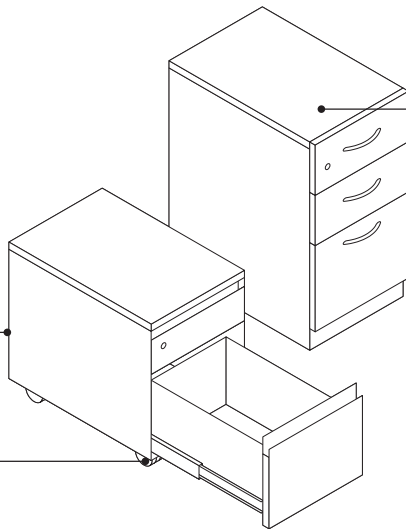
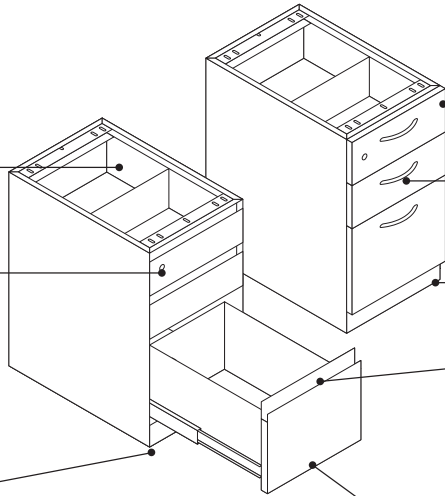

Drawer fronts are available in steel, laminate, or wood veneer. Mobile pedestals maintain drawer pull and drawer front alignment with other storage components that have a 3" base.

Pull on proud-front pedestal is available in a variety of shapes.

3"H base is integral to 27"H pedestal case.

Pull on flush-front pedestal is full width and integral. This pull is available on steel drawer fronts only. Full-width wood pull is available as an option. Wood pull, if selected, ships separately from pedestal and is field installed, attaching to the integral pull with double-sided tape.

Drawers open their full depth for total access to the contents. Box and file drawers are available.

Top on mobile pedestal is 1⁄8"H steel. Additional top options are available.

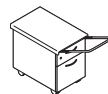

Mobile pedestal cushion top provides a temporary seat ideal for informal gatherings. Optional handle can be extended to easily transport mobile pedestal. Available factory- or field-installed.

- ▶ Specifying, page 627

Product Details

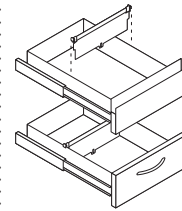

Box drawers are a welded steel construction and available with proud or flush fronts. One divider is included with each box drawer.

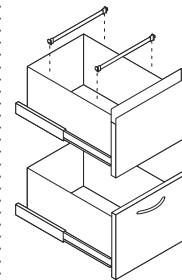

File drawers are a welded steel construction and available with proud or flush fronts. Drawer body sides are full height and accommodate front-to-back filing of hanging letter-size file folders.

Optional rails accommodate side-to-side filing of letter-, A4-, and legal-size hanging folders.
Exception: Legal-size file folders cannot be filed in 17½"D or 183⁄8"D pedestals.

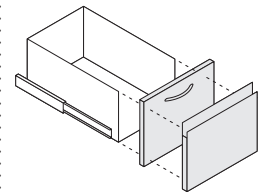

Drawer fronts can be removed and changed in the field to create a different aesthetic or to replace damaged drawer fronts.

Actual Dimensions

	Fixed	Box/File	Box/Box/File and File/File
Depth with flush steel front	17½", 225⁄8", and 285⁄8"	17½" and 225⁄8"	17½" and 225⁄8"
Depth with proud steel, laminate, or wood front	183⁄8", 23½", and 29½"	183⁄8" and 23½"	183⁄8" and 23½"
Width	15"	15"	15"
Height	25½" and 27"	N.A.	N.A.
Overall height with 1⁄8"H top	N.A.	21"	27"

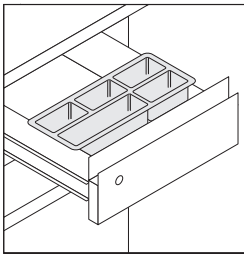

Pencil tray to hold small office supplies is included with each box/box/file pedestal.

Optional basic drawer interior allows box/box/file pedestals to be ordered without rails, box drawer dividers, or pencil trays.

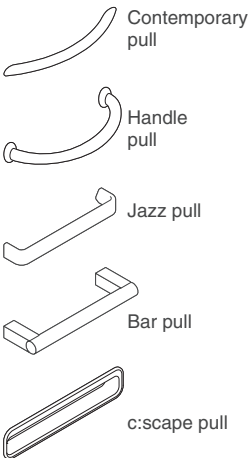

Proud-front pulls are available in the following styles—contemporary, handle, jazz, and bar. Each pull is 128 mm and available on steel or wood veneer drawers. c:scape pulls (200 mm) are available on steel drawers only.

Label holders are available through Service Parts. Label holder fits inside the integral pull of flush-front drawers and over the top edge of drawer front on proud-front drawers.

Safety interlock system allows only one drawer to be opened at a time for added stability.

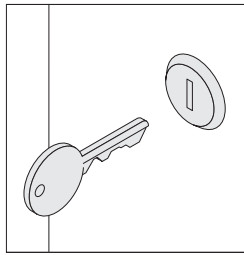

Locks are available factory- or field-installed. Factory-installed locks are standard and available keyed random only. Optional field-installed locks are available with consecutive, specific, and random keying options. Master-keyed locks are also available. Field-installed lock cylinders must be specified separately.

▶ *Lock and Keying*, page 686

Individual drawer locks are available on file/file pedestals for applications where you want to limit access to each drawer. Pedestals include a security shield above each drawer to prevent unauthorized access. Individual locking drawers are only available with field-installed lock cylinders. Consecutive, specific, and random keying options are available. Master-keyed locks are also available. Field-installed lock cylinders must be specified separately.

▶ *Lock and Keying*, page 686

Non-locking pedestal is available as an option.

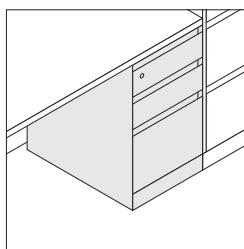

27" H fixed pedestals have base alignment with other Universal Storage components that have a 3" H base.

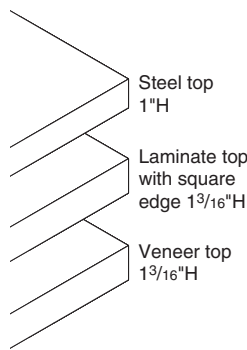

Steel, laminate, and wood veneer tops are available in place of standard 1/8" H steel tops, 1" H steel tops, 1 3/16" H laminate with square edge profile, and 1 3/16" H wood veneer with square edge profile.

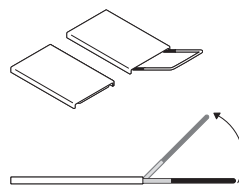

Handle of mobile pedestal cushion top is retractable. In the stowed position, handle is flush with mobile pedestal front. In the travel position, handle is completely extended and articulates upward for longer distance transport. Cushion top is also available without a handle.

Mobile pedestal cushion top for field-installation can be used with mobile pedestals **RPM2421CP**, **RPM2421CF**, and **RPM2421CW** only.

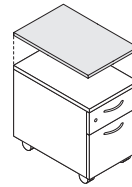

Basic cushion enhanced is ordered separately for use on Universal mobile pedestals with metal, laminate, or veneer top. Basic cushion enhanced is field-installed and attaches to the existing top with hook and loop fastener.

Basic cushion enhanced for field installation can be used with mobile pedestals **RPM1821CF**, **RPM1821CP**, **RPM1821CW**, **RPM2421CF**, **RPM2421CP**, and **RPM2421CW** only.

Counterweight packages are required to ensure product stability and are ordered as an option or separately. Product specification pages indicate the correct counterweight package for each style number and any exceptions where counterweights are not required.

Connections

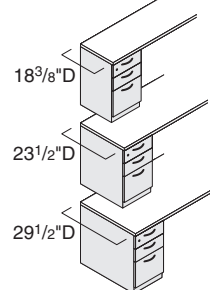

Fixed pedestals are intended to attach under a worksurface for security and support. Three pedestal depths are available to correspond with Universal Worksurface depths. Proud-front pedestals exactly match the depth of Universal Worksurfaces. Flush-front pedestals are 7/8" shorter.

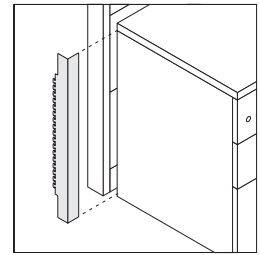

Filler conceals the gap that may exist between the face of a panel and the back of a 27" H pedestal. Fillers are also used to provide stability for pedestal and worksurface configurations that are not panel-wrapped.

Tip: Fillers for proud front pedestals conceal a 1/2" gap. Fillers for flush front pedestals conceal a 1 3/8" gap.

Freestanding applications that don't require attachment to a worksurface should be used with a conversion kit that includes a steel top, counterweight package, and components to convert the locking system to a safety interlock system.

▶ Page 601

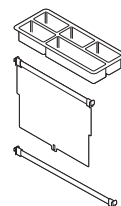

Field-installed accessories are available, including pencil trays, stationary trays, dividers, and rails.

▶ Page 655

Wiring & Cabling

Fixed pedestals do not accommodate cable-routing. Plan accordingly when installing pedestals underneath worksurfaces with grommets or other cable-routing accessories.

Universal Pedestals, continued

Surface Materials

Pedestal, steel drawer fronts, and integral pulls

- Paint

Contemporary, handle, jazz, and bar pulls

- 0835 Black
- 9201 Polished Chrome
- 9211 Nickel
- 9212 Silver

scape pull

- 4140 Arctic White Gloss
- 4144 Black Gloss
- 4799 Platinum Metallic

Wood veneer top and drawer fronts

- Wood veneer—
Open pore finishes
- Customiz stain (option)

Lock

- 9201 Polished Chrome
- 9250 Ember Chrome (option)

Drawer bodies, drawer suspensions, rails, dividers, and glides

- Black

Laminate top and drawer fronts

- Laminate
- Open Line laminate (option)

Square edge profile on laminate top

- Plastic

Cushion top

- Fabric
- Leather

Basic cushion enhanced

- Fabric

Tip: For both cushion top and basic cushion enhanced: fabric patterns with a linear design will always be applied from the front to back of the unit or the depth of the unit. Pattern matching will not be done on COM.

Application Topics

Storage Capacities and Dimensions

▶ See *Storage Specification Guide*

Counterweight Requirements for Storage Products

▶ Pages 265–272

Shipping

Fixed pedestals are normally shipped in heavy-duty, recyclable stretch wrap to reduce the amount of corrugated board needed.

Mobile pedestals are shipped in corrugated board to minimize damage during transport.

Universal Sliding Door Bins

For Use with Answer

Universal sliding door bins attach to panels with an on-module bracket and provide overhead storage in the work space. Door is available in steel or wood.

► Specifying, page 606

Safety catch locks overhead storage unit to frame to prevent accidental removal.

On-module attachment brackets are used to mount bins on panels of the same width as bins and are included with the bin as a standard component.

Steel, laminate, and wood front doors glide smoothly from one side of the case to the other.

Bin ships assembled.

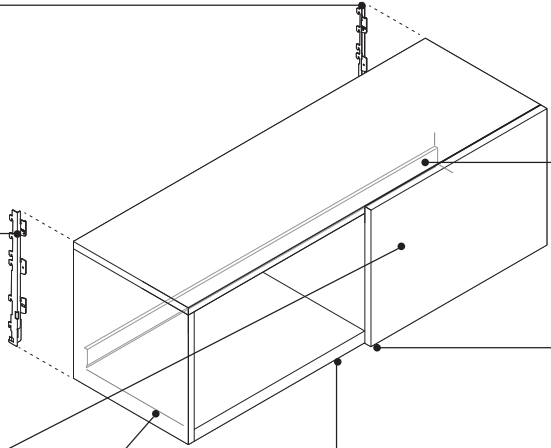

Metal backstop prevents notebooks and equipment from damaging panel surface.

Lock is standard on bins to secure the door. The door can be locked in the closed position on either the right- or left-hand side of the bin. Lock is located underneath the center of the shelf. Lock is standard factory-installed, keyed random. A no-lock option is available.

► *Lock and Keying*, page 686

Recess beneath unit can accommodate a shelf light.

► For lighting, see *Answer Freestanding Specification Guide*.

Product Details

On-module attachment brackets are independent of the storage bin and unique to the panel system they are used on. If the storage bin needs to be attached to a different panel in the future, additional on-module attachment brackets can be purchased through Service Parts.

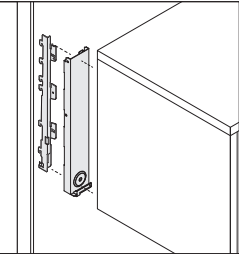

Vertical off-module brackets, optional, can be used to mount one or two sides of an overhead bin off-module on Answer, Kick, and Montage with vertical slot patterned panels. To mount an overhead bin with one side off-module, specify with one vertical off-module bracket. To mount an overhead bin with two sides off-module, specify with two vertical off-module brackets. Both of these brackets attach to the on-module bracket that comes standard with the overhead bin.

Vertical off-module brackets are used with bins up to 12" wider than the panel, allowing them to overhang the panel seam.

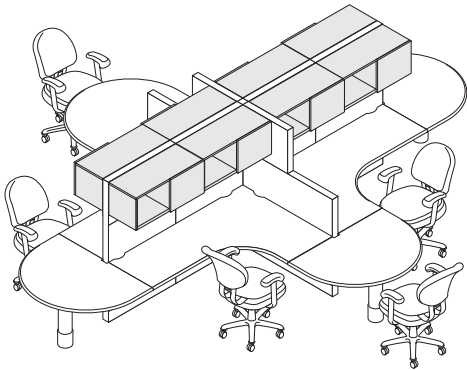

Actual Dimensions

Depth	15 ³ / ₄ "
Width	36", 42", 48", 60", 66", and 72"
Height	16 ¹ / ₄ "

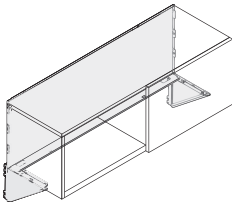

Upmount brackets, optional, are for use on Answer, Kick, and Montage. Brackets enable overhead storage to be used on lower panel heights. Bins using an upmount bracket must be installed on a panel of the same width.

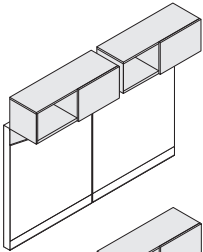

Two upmount bin brackets can be hung side-by-side in an in-line, T-, or X- application. Bin can be upmounted on slatwall skin as long as there is not another bin or another slatwall skin on the adjacent in-line panel.

Omit brackets option must be specified when bin is being used in hutch kit application, or when attaching bin to a horizontal wall attachment bracket. Order hutch kit separately.

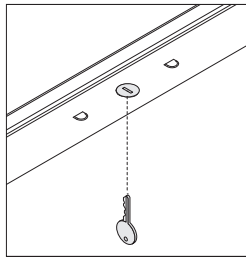

Lock in bin is concealed from view beneath the shelf. Locks are available factory- or field-installed. Factory-installed locks are standard and available keyed random only. Optional field-installed locks are available with consecutive, specific, and random keying options. Master-keyed locks are also available. Field-installed lock cylinders must be specified separately.

► *Lock and Keying*, page 686

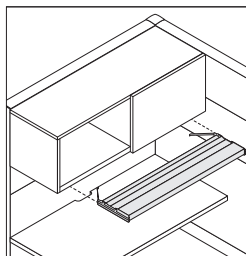

Shelf lights are available for use beneath bins. Lights recess into the bottom of the overhead storage unit.

► For lighting, see *Answer Freestanding Specification Guide*.

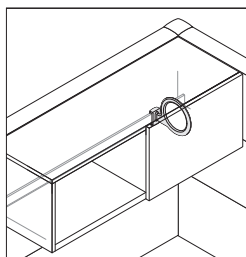

Dividers are available as an option for use on bins. Dividers ship in a package of four.

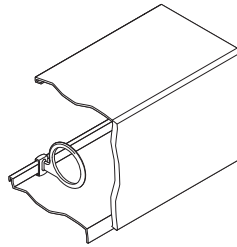

Back of storage bin is open to allow panel surface to show. Metal backstop prevents contents of bin from damaging panel surface.

Overhead storage bin height accepts standard and A4 binders.

When mounting on Answer or Kick panels, top of bin cannot be loaded.

Connections

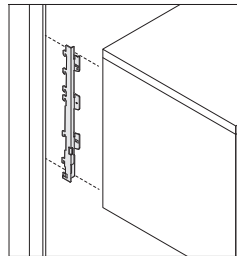

Steel support hooks on end supports insert into the slotted channel of a panel or wall channel and lock into place with a safety catch.

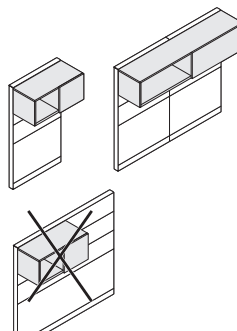

Width of overhead bin must match the width of the panel or panels that it is attached to when using an on-module bracket. Bin may span up to two frames.

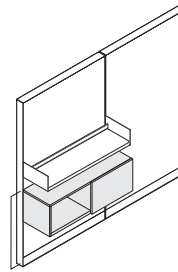

38"H

Universal sliding door bin may be mounted at 38"H or lower if another panel-mounted component prevents it from being seated upon.

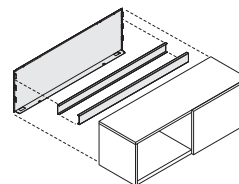

Horizontal wall attachment brackets are available to attach storage bins to wall of building. Specify as separate style number.
Tip: Select the omit brackets option when ordering the bin.

Wiring & Cabling

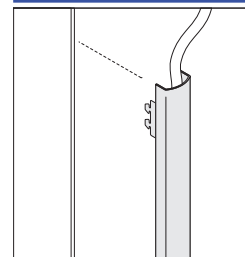

Vertical wire managers are available to conceal cords that are routed from light mounted beneath overhead storage.

► For lighting, see *Answer Freestanding Specification Guide*.

Surface Materials

Overhead bin

- Paint
- Wood door (optional)

Locks

- 9201 Polished Chrome
- 9250 Ember Chrome (optional)

On-module and vertical off-module attachment brackets

- Black paint only

Upmount brackets

- Paint

Dividers

- White plastic

Application Topics

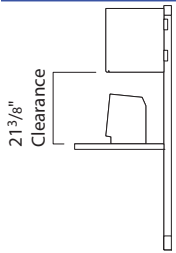

Clearance between Universal Systems Worksurfaces or Universal tables and bottom of overhead bins is 21³/₈" when storage unit is installed in the highest position on a 66"H panel and glides are adjusted all the way into the panel.

Storage Capacities and Dimensions

▶ See *Storage Specification Guide*

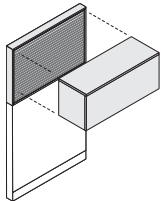

Overhead bins can be hung in front of slatwall skins.

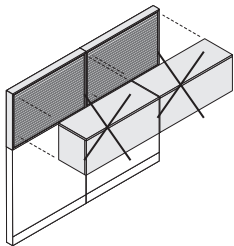

Two bins cannot be hung side by side if one or both bins are in front of a slatwall skin.

Bracket Application Rules

▶ Page 294

Stability Guidelines

▶ Page 140

Guidelines for Answer Panel-Hung Components

▶ Page 141

Guidelines for Stackable Components

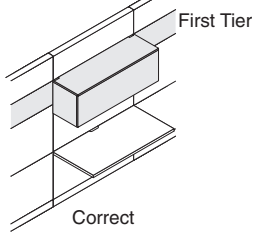

Correct

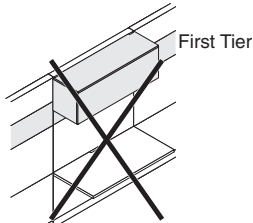

Incorrect

TS Series bins, Universal bins, and shelves can hang from the first stacked tier only.

Universal Over The Case and In The Case Bins

For Use with Answer

Universal over the case bins can be attached to panels with an on-module bracket and provide overhead storage in the work space.

► Specifying, page 608

Safety catch locks overhead storage unit to frame to prevent accidental removal.

On-module attachment brackets are used to mount bins on panels of the same width as bins and are included with the bin as a standard component.

Backstop prevents notebooks and equipment from damaging the surface of the panels or walls.

Bin is steel and ships assembled.

Universal in the case bins, attach to panels with an on-module bracket and provide overhead storage in the work space. Door is available in steel, laminate, or wood.

► Specifying, page 610

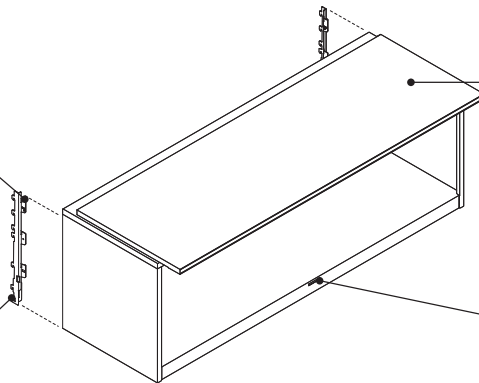

Flat-front lift-up doors open and close quietly. When up, the doors rest on top of the case to provide more storage space inside.

Locks are standard on bins to secure the door(s). Lock is located underneath the center of the shelf. Locks are standard factory-installed, keyed random. Two-door units are keyed alike. A no-lock option is available.

► Lock and Keying, page 686

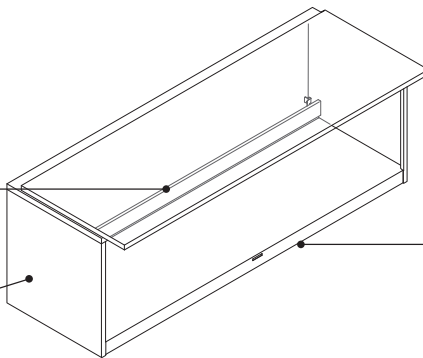

Recess beneath unit can accommodate a shelf light.

► For lighting, see *Answer Freestanding Specification Guide*.

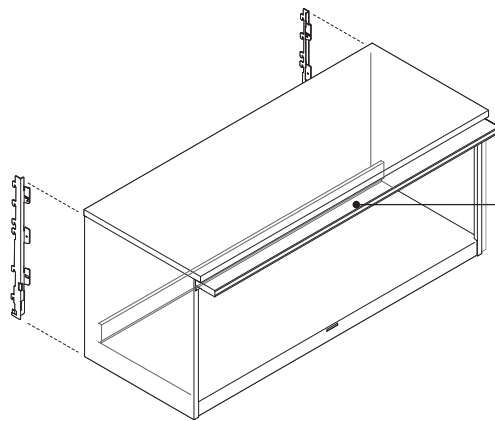

Flat-front lift-up doors (steel, laminate, or wood) recess into the overhead storage bin.

Product Details

On-module attachment brackets are independent of the storage bins and unique to the panel system they are used on. The following style number suffixes indicate the panels they attach to:

TAK = Answer and Kick
MON = Montage

If the storage bin needs to be attached to a different panel in the future, additional on-module attachment brackets can be purchased through Service Parts.

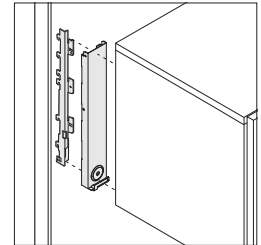

Vertical off-module brackets, optional, can be used to mount one or two sides of an overhead bin off-module on Answer, Kick, and Montage with vertical slot patterned panels. To mount an overhead bin with one side off-module, specify with one vertical off-module bracket. To mount an overhead bin with two sides off-module, specify with two vertical off-module brackets. Both of these brackets attach to the on-module bracket that comes standard with the overhead bin.

Vertical off-module brackets are used with bins up to 12" wider than the panel, allowing them to overhang the panel seam.

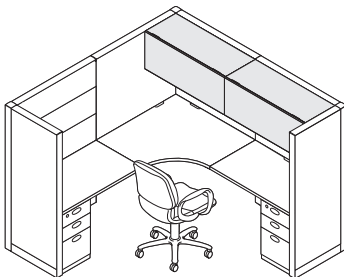

Actual Dimensions

Depth 15³/₄"

Width 24", 30", 36", 42", 48", 60", 66", and 72"

Height 16¹/₄"

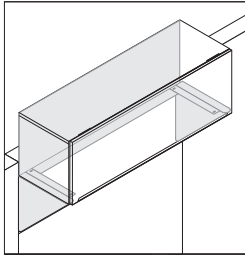

Picture frame door—omit insert, optional, is available on Universal over the case and in the case bins with flat steel fronts only. An omit insert option allows custom material to be field installed in the aluminum door frame.

The omit insert custom material must be ordered from a material vendor. If an omit insert option is specified and a door assist mechanism is also required, an assist mechanism must be specified as a separate option to the storage bin. The weight of a custom insert on a Universal over the case bin can not exceed 10½ pounds. An insert for a Universal over the case storage bin door with an assist mechanism must weigh within the range of 7¼ pounds to 10½ pounds or the assist mechanism will not function correctly. Custom materials being installed in a door insert must comply with local building codes. Consult with local authorities to determine compliance requirements. The use of safety glass is required if installing custom glass in a door insert. To install customer provided material in a picture frame door with the insert omitted, make sure the material is cut precisely to the sizes listed on the dimensions matrix. ▶ See *Dimensions for Custom Field-Installed Picture Frame Door Inserts*, page 289

Upmount brackets are optional for use on Answer, Kick, and Montage. Brackets attach the bin near the top of 54"H panel to enable overhead storage to be used on lower panel heights. Bins using an upmount bracket must be installed on a panel of the same width.

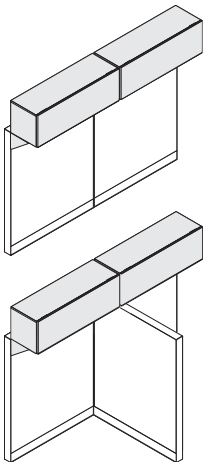

Two upmount bin brackets can be hung side by side in an in-line, T-, or X-application. Bin can be upmounted on slatwall skin as long as there is not another bin or another slatwall skin on the adjacent in-line panel.

Omit brackets option must be specified when bin is being used in hutch kit application, or when attaching bin to a horizontal wall attachment bracket. Order hutch kit separately.

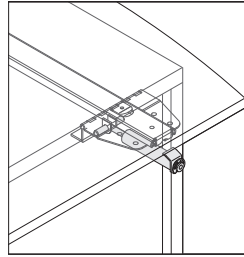

Door assist mechanism, optional, consist of a gas cylinder and spring that provides an assisted open and close of the door. When opening the door, the spring pulls the door to the fully recessed position. When closing the door, the assist mechanism will slowly close the door. Universal bins ship with two assist mechanisms per door when specified.

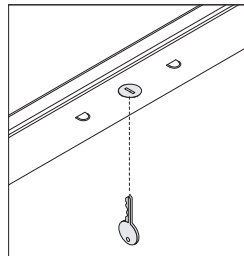

Lock in bin is concealed from view beneath the shelf. Locks are available factory-installed or field-installed. Factory-installed locks are standard and available keyed random only. Two-door units are keyed alike. Optional field-installed locks are available with consecutive, specific, and random keying options. Master-keyed locks are also available. Field-installed lock cylinders must be specified separately. ▶ *Lock and Keying*, page 686

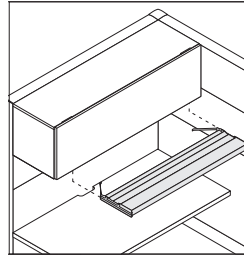

Shelf lights are available for use beneath bins. Lights recess into the bottom of overhead bins. ▶ For lighting, see *Answer Freestanding Specification Guide*.

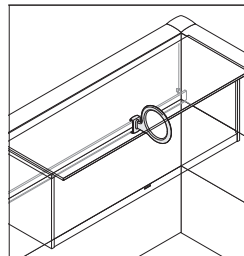

Divider is available as an option on overhead bins. Dividers ship in a package of four. ▶ Page 292

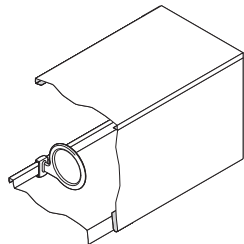

Back of storage bin is open to allow panel surface to show. Metal backstop prevents contents of bin from damaging panel surface.

Overhead storage bin height accepts standard and A4 binders.

When mounting on Answer or Kick panels, top of bin cannot be loaded.

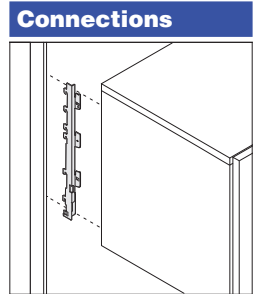

Steel support hooks on end supports insert into the slotted channel of a panel or wall channel and lock into place with a safety catch.

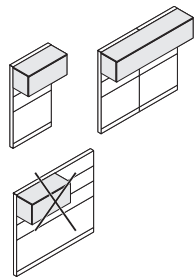

Width of overhead bin must match the width of the panel or panels that it is attached to when using an on-module bracket. Bin may span up to two frames.

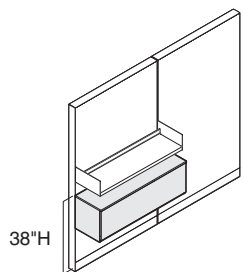

Universal over the case bin may be mounted at 38"H or lower if another panel-mounted component prevents it from being seated upon.

Universal Over The Case and In The Case Bins for Use with Answer, continued

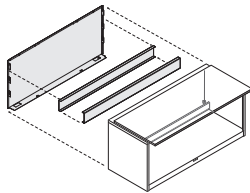

Horizontal wall attachment brackets are available to attach storage bins to wall of building. Specify as a separate style number.
Tip: Select the omit brackets option when ordering the bin.

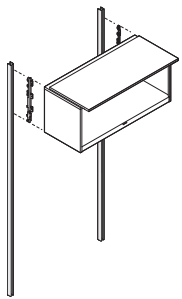

Wall channels are available to attach bins to concrete or block walls. Wall channels can be used to attach bins and tackboards to wood, dry wall, or plaster walls if the wall is reinforced.

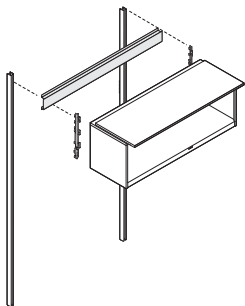

Wall channel horizontal brace is required with wall channels to support bins that are wider than 48".

Wiring & Cabling

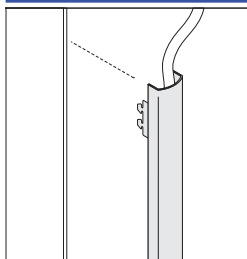

Vertical wire managers are available to conceal cords that are routed from light mounted beneath overhead storage.

► For lighting, see *Answer Freestanding Specification Guide*.

Surface Materials

Overhead bin

- Paint

Lock

- 9201 Polished Chrome
- 9250 Ember Chrome (optional)

On-module and vertical off-module attachment brackets

- Black paint only

Horizontal off-module attachment brackets for Montage

- Paint to match bin

Upmount brackets

- Paint

Dividers

- White plastic

Application Topics

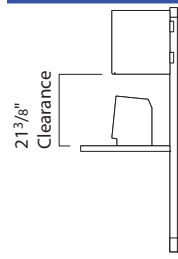

Clearance between worksurfaces and bottom of overhead bins is 21³/₈" when storage unit is installed in the highest position on a 66"H panel and glides are adjusted all the way into the panel.

Storage Capacities and Dimensions

► For interior dimensions, see *Storage Capacities and Dimensions* in the *Storage Specification Guide*.

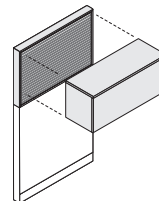

Overhead bins can be hung in front of slatwall skins.

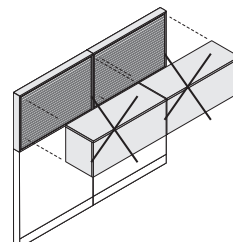

Two bins cannot be hung side by side if one or both bins are in front of a slatwall skin.

Bracket Application Rules

► Page 294

Stability Guidelines

► Page 140

Guidelines for Answer Panel-Hung Components

► Page 141

Guidelines for Stackable Components

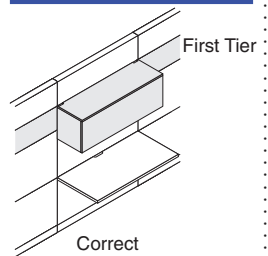

Correct

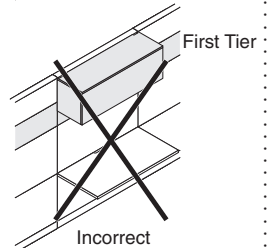

Incorrect

TS Series bins, Universal bins, and shelves can hang from the first stacked tier only.

Dimensions For Custom Field-Installed Picture Frame Door Inserts

Dimensions For Custom
Field-Installed Picture
Frame Door Inserts

For Universal Over the Case Bins

Bin Width	Door Width	Custom Picture Frame Door Inserts		
		Height +/-0.02"	Width +/-0.02"	Thickness +/-0.02"
24"	24"	15.933"	23.314"	0.138"
25"	25"	15.933"	24.314"	0.138"
30"	30"	15.933"	29.314"	0.138"
35"	35"	15.933"	34.314"	0.138"
36"	36"	15.933"	35.314"	0.138"
42"	42"	15.933"	41.314"	0.138"
45"	45"	15.933"	44.314"	0.138"
48"	48"	15.933"	47.314"	0.138"
60"	30" (per door)	15.933"	29.314"	0.138"
66"	33" (per door)	15.933"	32.314"	0.138"
70"	35" (per door)	15.933"	34.314"	0.138"
72"	36" (per door)	15.933"	35.314"	0.138"
75"	37½" (per door)	15.933"	36.314"	0.138"

Tip: A custom insert cannot be factory installed. Custom insert must be ordered from a material vendor and will not be handled like a Steelcase Customer's Own Material. In selecting materials for customer supplied inserts, consider material characteristics, such as effects from thermal changes, humidity changes, aging characteristics, and strength of material. Do not use materials that allow the overall size of the custom insert to deviate by amounts larger than the acceptable tolerances listed in the matrix.

For Universal In the Case Bins

Bin Width	Door Width	Custom Picture Frame Door Inserts		
		Height +/-0.02"	Width +/-0.02"	Thickness +/-0.02"
24"	24"	15.000"	23.164"	0.138"
25"	25"	15.000"	24.164"	0.138"
30"	30"	15.000"	29.164"	0.138"
35"	35"	15.000"	34.164"	0.138"
36"	36"	15.000"	35.164"	0.138"
42"	42"	15.000"	41.164"	0.138"
45"	45"	15.000"	44.164"	0.138"
48"	48"	15.000"	47.164"	0.138"
60"	30" (per door)	15.000"	29.164"	0.138"
66"	33" (per door)	15.000"	32.164"	0.138"
70"	35" (per door)	15.000"	34.164"	0.138"
72"	36" (per door)	15.000"	35.164"	0.138"
75"	37½" (per door)	15.000"	36.664"	0.138"

Tip: A custom insert cannot be factory installed. Custom insert must be ordered from a material vendor and will not be handled like a Steelcase Customer's Own Material. In selecting materials for customer supplied inserts, consider material characteristics, such as effects from thermal changes, humidity changes, aging characteristics, and strength of material. Do not use materials that allow the overall size of the custom insert to deviate by amounts larger than the acceptable tolerances listed in the matrix.

Universal Steel Storage

Universal Shelves and Universal Personal Shelves

For Use with Answer

Universal shelves—supported by Answer, Kick, and Montage—provide overhead storage in the work space.

► Specifying, page 613

Universal personal shelves provide a wall-supported surface that attaches to Answer and Kick

► Specifying, page 614

Metal backstop on Universal shelves

prevents notebooks and equipment from damaging panel surface. Universal personal shelves do not have a backstop.

On-module attachment hooks

are integral to the end supports and are used to mount shelves on panels of the same width as bins.

Safety catch locks shelf units to frame to prevent accidental removal.

Shelves are steel and ship ready to assemble.

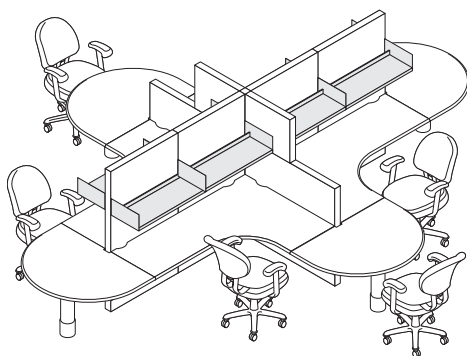

Actual Dimensions

	Universal shelves	Universal personal shelves
Depth	14 ³ / ₄ "	13 ¹ / ₁₆ "
Width	24", 30", 36", 42", 48", 60", and 72"	24", 30", 36", 42", and 48"
Height	7 ¹ / ₂ " (Kick and Answer)	1 ¹ / ₁₆ " (thickness of shelf)

Product Details

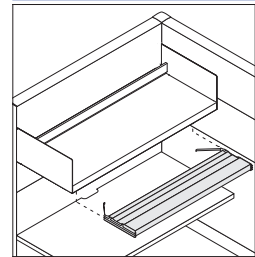

Shelf lights are available for use beneath shelves. Lights recess into the bottom of the overhead storage unit.

► For lighting, see *Answer Freestanding Specification Guide*.

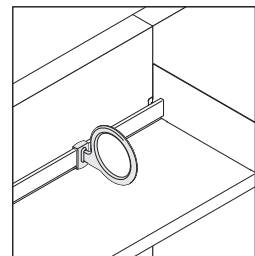

Dividers are available field installed for use on Universal shelves. Dividers ship in a package of four. Dividers cannot attach to Universal personal shelves.

A 1¹/₂" gap exists between the personal shelf and the panel to allow for cable routing.

The height dimension of the bracket (from top of personal shelf to the bottom of the bracket) is 6¹/₂" H.

Connections

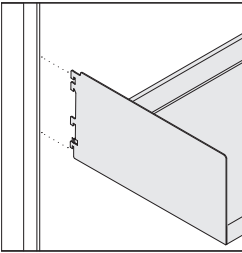

Steel support hooks on end supports insert into the slotted channel of a panel or wall channel and lock into place with a safety catch.

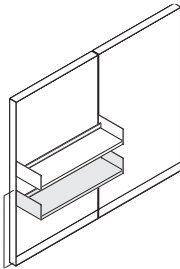

Universal shelf may be mounted at 38"H or lower if another panel-mounted component prevents it from being seated upon.

On-module attachment hooks cannot be attached to upmount brackets.

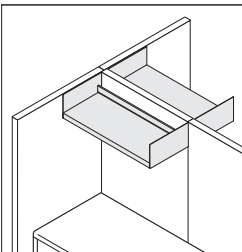

Width of shelf must match the width of the panel or panels that it is attached to with the on-module brackets. Shelves may span up to two frames.

Wiring & Cabling

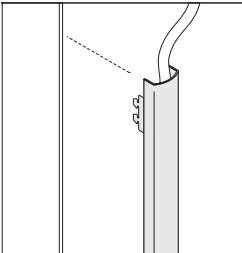

Vertical wire managers conceal cords and cables that are routed vertically outside of the panels.
▶ For lighting, see *Answer Freestanding Specification Guide*.

Surface Materials

Shelf
• Paint

Application Topics

Storage Capacities and Dimensions
▶ For interior dimensions, see *Storage Capacities and Dimensions* in the *Storage Specification Guide*.

Bracket Application Rules
▶ Page 294

Stability Guidelines
▶ Page 140

Guidelines for Stackable Components

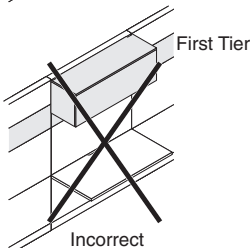
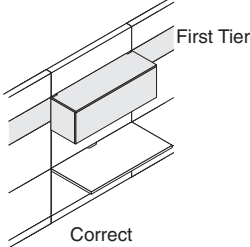

TS Series bins, Universal bins, and shelves can hang from the first stacked tier only.

Dividers

Dividers

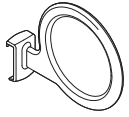

► Specifying, page 614

Product Details

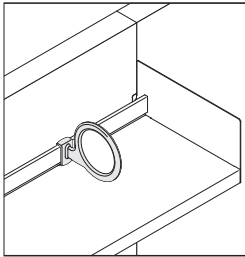

Divides space in panel-supported bins and Universal shelves. Dividers will not work in bins and shelves introduced prior to March 2007.

Divider can be used on hutch kit.

Specifying

A carton of four dividers is available as an option on overhead bins and Universal shelves.

Surface Materials

Divider
• White plastic only

Actual Dimensions

Depth	7½"
Width	¼" 1½" at the back
Height	6½"

Dividers for Overhead Storage Bins and Shelves Introduced prior to March 2007

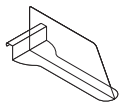

► Specifying, page 615

Product Details

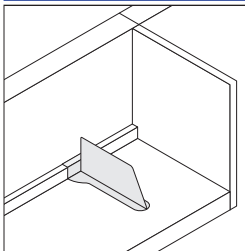

Divides space in bins and shelves.

Surface Materials

Divider
• Clear textured plastic only

Actual Dimensions

Depth	10¾"
Width	4" at the back ½" at the front
Height	4½"

Slim Shelves

Slim shelves provide a panel-supported surface that attaches to Answer, Kick, and Montage with panel-specific brackets.

► Specifying, page 619

Slim shelf is an extruded aluminum shelf that provides storage for small items.

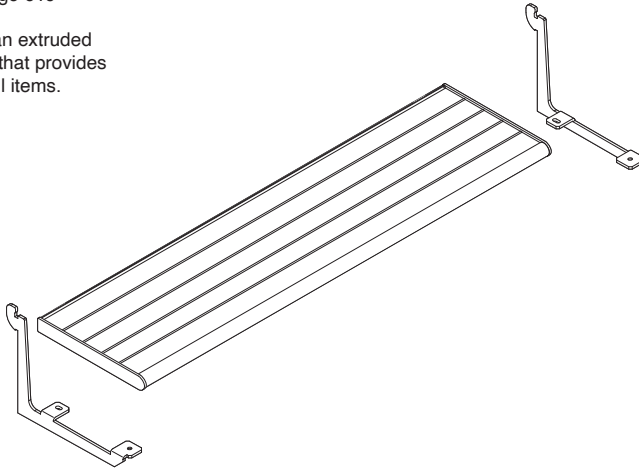

Product Details

Slim shelves attach to Answer, Kick, and Montage with panel-specific brackets.

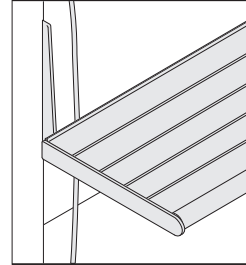

Gap at back of slim shelf allows routing of shelf light cord.

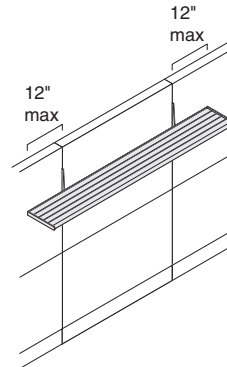

Slim shelves can be mounted off-module. No more than 12" overhang on either side of panel is recommended. Brackets attach on vertical seams of panel, while the shelf adjusts off-module on the brackets.

Two attachment brackets are included with shelves less than or equal to 48"W. Two attachment brackets and a mid-span support are included with shelves wider than 48"W.

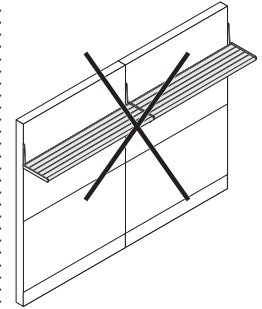

Answer will not support two shelves installed end to end.

Surface Materials

Slim shelves

- Paint

Attachment brackets

- Painted to match shelf

Actual Dimensions

Depth 6³/₈"

Width 24", 30", 36", 42", 48", 60", 72", 96"

Bracket Application Rules for Bins and Shelves

For TS Series Bins, Universal Sliding Door Bins, Universal Over the Case Bins, Universal In the Case Bins, and Universal Shelves

Bracket Application Matrix

Panels	TS Series Bins, Universal Bins, and Universal Shelves—On-Module	Universal Bins—Single Side Vertical Off-Module	Universal Bins—Two Sided Vertical Off-Module	Universal Bins—Horizontal Off-Module (for use with and Montage only)	Universal Bins—Upmount
Answer	•	•	•		•
Kick	•	•	•		•
Montage	•	•	•	•	•

On-Module Brackets and Hooks

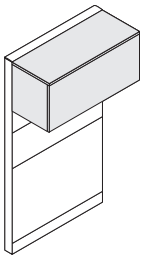

On-module brackets and hooks are used to mount overhead bins and Universal shelves to panels with vertical slot patterns. Answer, Kick, and Montage panels can support on-module attachment brackets.

Universal personal shelves can attach on-module to all panels except Montage.

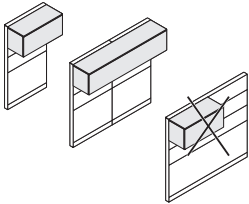

Width of overhead storage unit must match the width of the panel or panels that it is attached to. Storage bins or shelves may span up to two panels.

Additional support for stability may be required when shelves and overhead storage bins are attached to panels. Counterbalancing loads on the opposite sides of the panels increases stability. *Tip: See Stability Guidelines in each corresponding specification guide.*

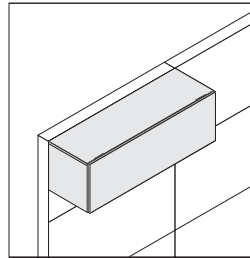

On-module attachment brackets install in panel seams.

On-module brackets can be used above and adjacent to slatwall on Answer and Montage Panels.

On-module brackets can be used with a panel stacker on Answer, Kick, and Montage panels. Follow standard panel stacker guidelines for each panel.

Off-module brackets are used with bins up to 12" larger than the panel, allowing them to overhang the panel seam.

Off-Module Brackets

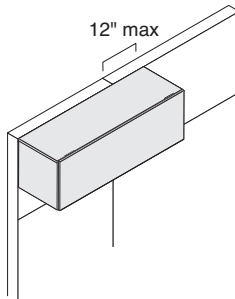

Vertical off-module brackets can be used above and adjacent to slatwall on Answer and Montage panels.

Vertical off-module brackets can be used with a panel stacker on Answer, Kick, and Montage panels. Follow standard panel stacker guidelines for each panel.

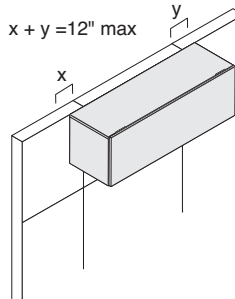

Vertical off-module brackets, optional, can be used to mount one or two sides of the overhead bin off-module on Answer, Kick, and Montage with vertical-slot-patterned panels. Both of these brackets attach to the on-module bracket that comes standard with the overhead bin. Vertical off-module brackets allow bins to be installed a maximum of 12" off-module. Vertical off-module brackets can be used with 30"W to 60"W Montage bins only.

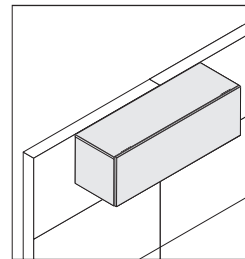

Horizontal off-module brackets, optional, accommodate off-module installations of overhead storage bins on panels with horizontal slot patterns. Enhanced off-module Montage frames can support horizontal off-module brackets. Horizontal off-module brackets can be used with 24"W to 48"W Montage bins only.

Horizontal off-module brackets can be used above and adjacent to slatwall on Montage panels.

Horizontal off-module brackets can be used with a panel stacker on Montage panels. Follow standard panel stacker guidelines for each panel.

Enhanced off-module Montage frames have horizontal slot patterns and must be specified for horizontal off-module Montage configurations.

Horizontal off-module brackets push bin out from panel 5/8" on enhanced off-module Montage panels.

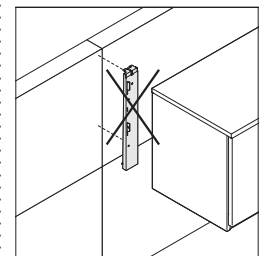

Horizontal off-module brackets cannot span a vertical or joint where two frames come together on enhanced off-module Montage panels. Shift the bin to avoid the joint.

Only two pairs of off-module brackets and associated storage can be mounted per frame.

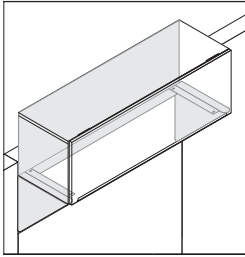

Omit Brackets

Omit brackets option must be specified when bin is used in hutch kit or when attaching bin to a horizontal wall attachment bracket. Order hutch kit separately. Hutch kit supports bin at 66" height.

Upmount brackets, optional, can be used with Universal sliding door, Universal over the case, and Universal in the case bins. Brackets attach bins near the top of 54"H panels. TS Series bins and Universal shelves cannot be attached to upmount brackets.

Upmount bin width must match the width of the panel or panels that it attaches to. Upmounted bins and shelves cannot be supported off-module.

Upmount brackets can be used with a panel stacker on Answer, Kick, and Montage panels. Follow standard panel stacker guidelines for each panel.

Application Rules for Overhead Storage on Answer and Kick Panels

Tip: For complete panel specific stability guidelines, see the corresponding panel specification guide.

Answer Panel

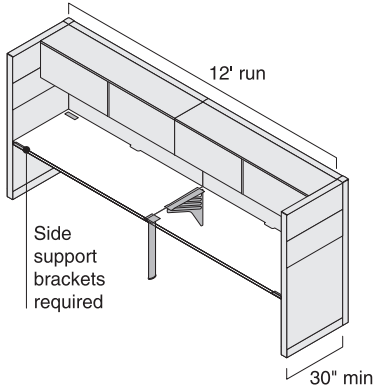

Guidelines for Universal Bins. Applies to universal sliding door bin or universal in the case bin on Answer and Kick panels.

The following application restrictions must be complied with when hanging universal overhead bins on Answer and Kick panels. Otherwise, standard Answer and Kick application guidelines apply.

- If bins or shelves are applied at an elevation higher than 66", a perpendicular panel of same height (or up to 24" lesser height) is required.
- The maximum panel run length when using a universal overhead bin on Answer or Kick panels is 12'.
- Top of bins and shelves are not designed to support the weight of a seated person. Bins and shelves may be mounted at 38"H or lower only if another panel-mounted component prevents it from being seated upon.
- When ganging binder bins, the use of a tie plate is required.

WARNING

Failure to comply to these guidelines may result in personal injury.

Kick Panel

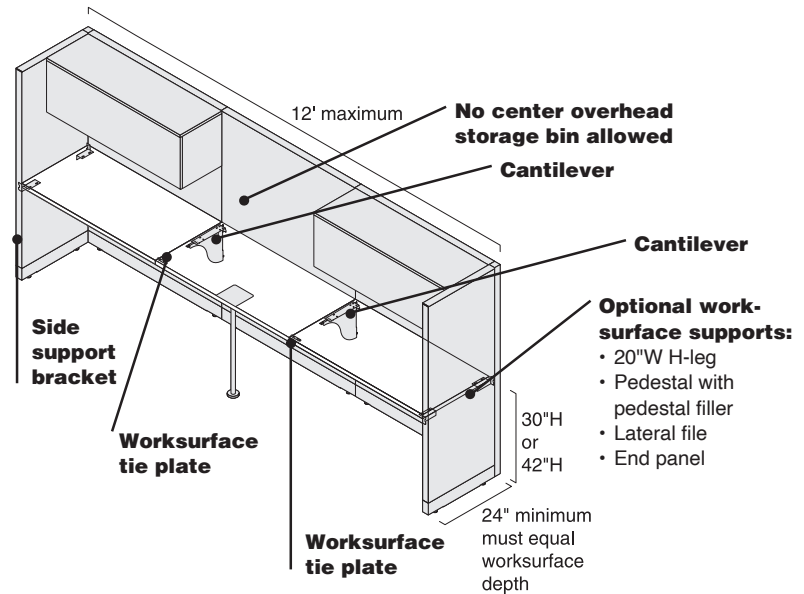
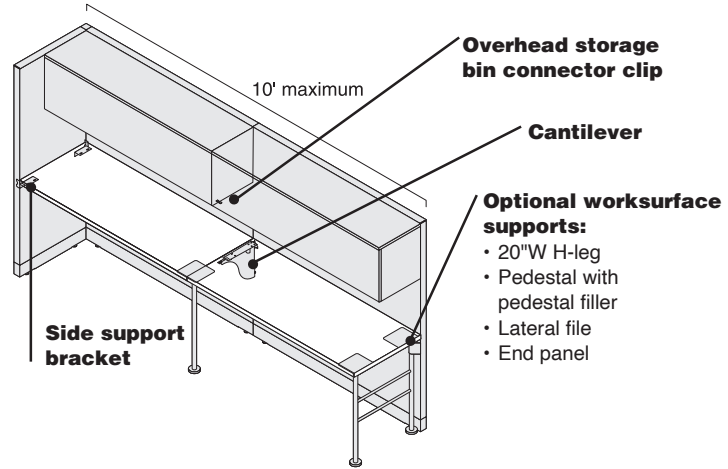

Universal One-High, 1.5-High, and Two Drawer Lateral Files

One-High and Two Drawer lateral files serve a dual purpose as high-density storage and as an inviting space for guests.
▶ Specifying, page 620

1.5-high lateral files provide multi-zone storage for binders, hanging folders, and piling surfaces at a height which allows for comfortable guest seating in collaborative environments.
▶ Specifying, page 620

Label holders are included with each drawer. Label holder fits inside the integral pull or can be affixed to the front of the drawer or door. Perforated labels are included and can be created using the template available on www.steelcase.com/label.

Finished back is standard.

Three base options are available: the universal 3" base, FrameOne foot, and c:scape glide. All three bases have the same overall height.

Lock is standard on lateral files and is located at top left corner of drawer. Locks are standard factory-installed, keyed random.
▶ Lock and Keying, page 686

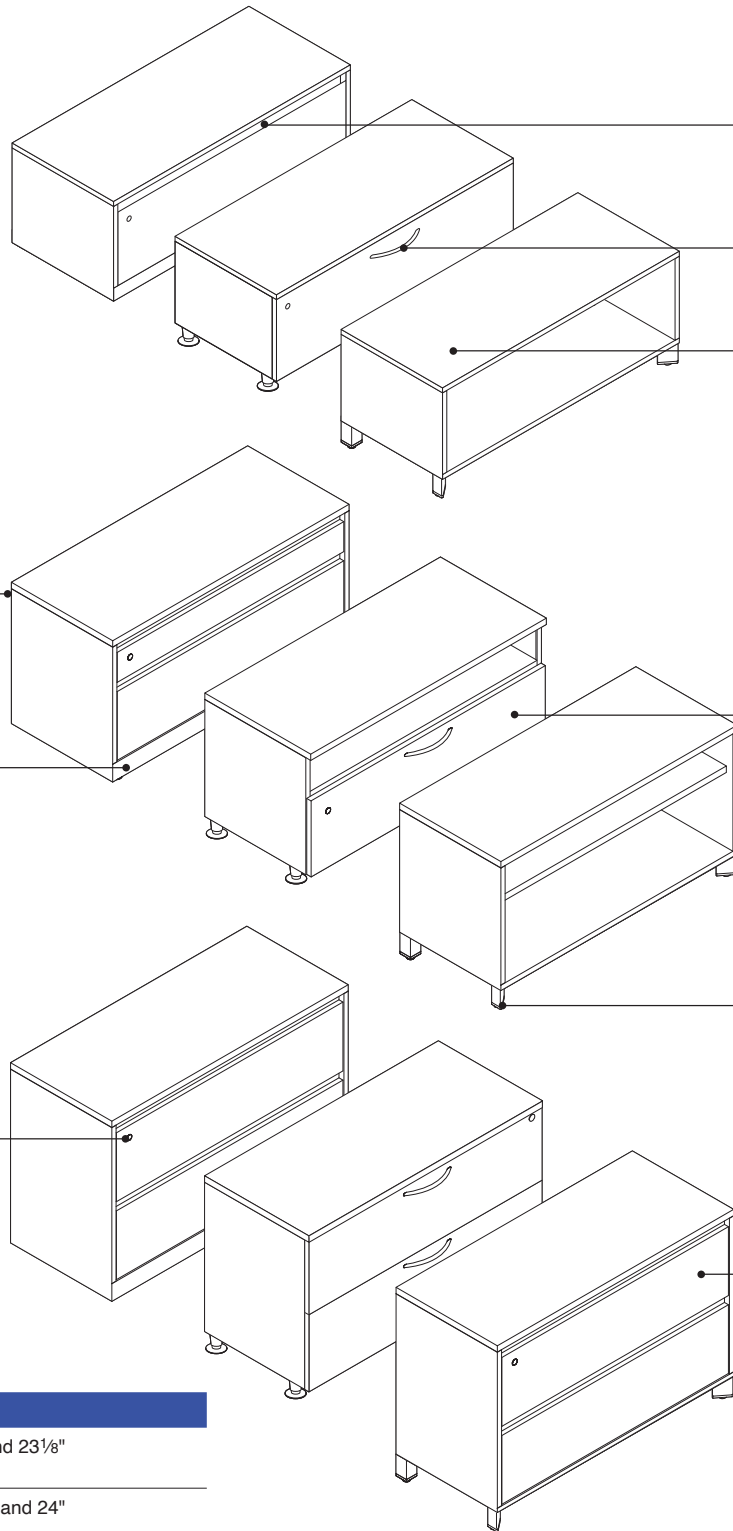

Pulls on flush-front lateral files are full width and integral.

Pulls on proud-front lateral files are available in a variety of shapes.

Top is standard 1"H steel on units with steel fronts and standard 1³/₁₆"H wood veneer on units with wood fronts. Other top options are available.

Drawer fronts are available in steel, laminate, or wood veneer.

Leveling glides adjust up to 3/4" for universal 3" base and up to 1" for c:scape glide and FrameOne foot base to install lateral file on uneven floors.

Drawers are standard 12"H and open full depth for total access to the contents.

Actual Dimensions

Depth with flush steel or open front 18" and 23¹/₈"

Depth with proud steel, laminate, or wood front 18⁷/₈" and 24"

Width 30", 36", and 42"

Height 16", 22", and 28"

Product Details

Base options



Universal 3" Base

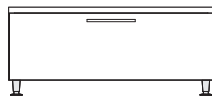

c:scape Glide Base

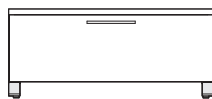

FrameOne Foot Base

Tip: All base options have same overall height.

Tip: Power infeed sits proud of the panel approximately 3" and will interfere with Universal storage with the Universal 3" base, FrameOne foot base, or c:scape glide.

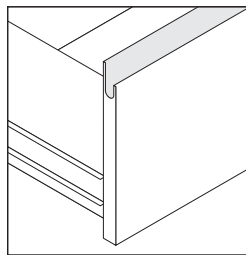

Flush-front pull is full width and integral with the drawer. Pull is available on steel drawers only.



Contemporary pull



Handle pull



Jazz pull

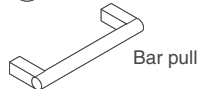

Bar pull



c:scape pull

Proud-front pulls are available in the following styles—contemporary, handle, jazz, and bar. Each pull is 192 mm and available on steel or wood veneer drawers. c:scape pulls (200 mm) are available on steel only.

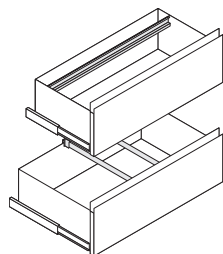

Drawer interiors include one hanging folder bar per drawer in each 18"D case and two rails per drawer in each 24"D case. Alternative interiors are available as options.

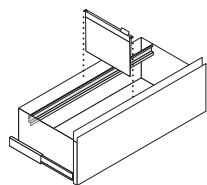

Hanging folder bar accommodates side-to-side filing of letter-, A4 international-, and legal-size hanging folders. Additional bars are available and must be specified separately. ▶ Page 656

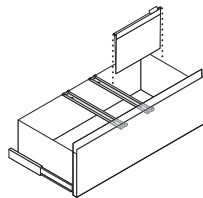

Rails accommodate front-to-back filing of letter-, A4 international-, and legal-size hanging folders. Rail packages accommodate two rows of letter-size files in 30"W and 36"W drawers and three rows of letter-size files in 42"W drawers. See *Storage Capacities* for additional details. Additional rails are available and must be specified separately.

▶ For interior dimensions, see *Storage Capacities and Dimensions* in the *Storage Specification Guide*.

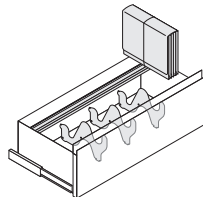

Dividers accommodate side-to-side filing of expandable folders and other objects. Divider packages include three dividers per drawer, 12"H file drawers also include one hanging folder bar per drawer. Additional dividers are available and must be specified separately. ▶ Page 657

Safety interlock system allows only one drawer to be opened at a time.

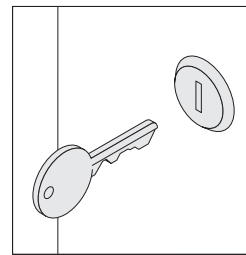

Locks are available factory- or field-installed. Factory-installed locks are standard and available keyed random only. Optional field-installed locks are available with consecutive, specific, and random keying options. Master-keyed locks are also available. Field-installed lock cylinders must be specified separately. ▶ *Lock and Keying*, page 686

Individual drawer locks are available as an option for an application that would limit access to each drawer. Lateral files include a security shield between drawers to prevent unauthorized access. Individual locking drawers are only available with field-installed locks. Consecutive, specific, and random keying are available. Field-installed lock cylinders must be specified separately. ▶ *Lock and Keying*, page 686

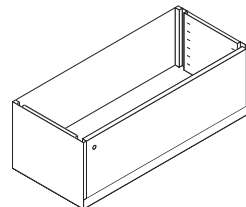

No-top lateral files are available for use with cushion top or beneath a common top shared among several lateral files. Hardware is included to attach case to worksurface. No-top option reduces height of file by 1".

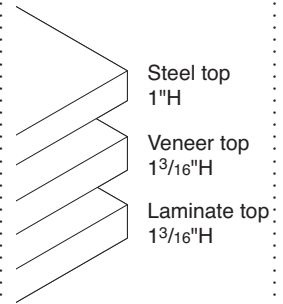

Steel top
1"H

Veneer top
1³/₁₆"H

Laminate top
1³/₁₆"H

Laminate and wood veneer tops with square-edge profiles are available in place of standard 1"H steel tops. Laminate and wood veneer tops are ³/₁₆" taller than steel tops and will add that dimension to the overall height of the lateral file.

Universal One-High, 1.5-High, and Two Drawer Lateral Files, continued

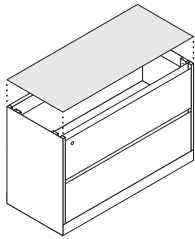

Security top is available as an option for installations where the file will be installed beneath a worksurface, but not physically attached. Thin steel top prevents unauthorized access to the contents of the cabinet. Security top is not structural and can be specified on 28"H files only. Security top reduces overall height of file to approximately 27"H.

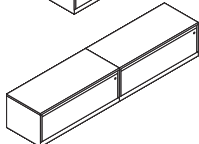
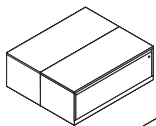

Ganging hardware is included to provide alignment by joining adjacent components side-by-side, back-to-back, or both.

Counterweight packages are required to ensure product stability and are ordered as an option or separately. Product specification pages indicate the correct counterweight package for each style number and any exceptions where counterweights are not required.

Connections

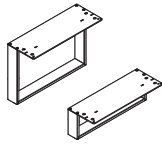

Intermediate support is used with Universal One-High or 1.5-High storage as a worksurface support allowing for nesting of low storage.

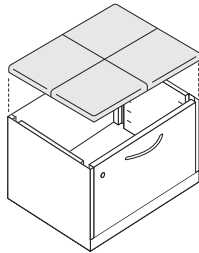

Cushion top is ordered separately for use on One-High, 1.5-High, and Two Drawer lateral files without top.

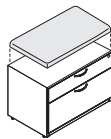

Basic cushion enhanced is ordered separately for use on Universal One-High, 1.5-High, and Two Drawer laterals with metal, laminate, or veneer top. Basic cushion enhanced is field-installed and attaches to the existing top with hook and loop fastener. *Tip: Basic cushion enhanced is available on Universal lateral files with a top only.*

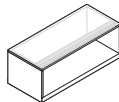

When applying the basic cushion enhanced on 30"W or 36"W Universal laterals with an open configuration, a support brace must also be specified.

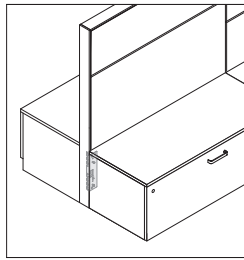

Floor anchor bracket (for TS Series Storage and Universal Storage with 3" base) secures lateral files, towers, cabinets, or bookcases to the floor for stability or to reduce the risk of hazards during earthquakes in seismic zones. Four bracket packages are required for each cabinet. *Note: Local seismic requirements vary.*

Compliance with local code requirements is the responsibility of the customer or their authorized agent.

For a California Office of Statewide Health Planning and Development (OSHPD) approved anchor bracket, contact Steelcase Specials. Tip: Anchor bracket cannot be used with pedestals.

▶ Page 661

Storage to panel bracket connects One-High, 1.5-High, 2-High, 3-High laterals and cabinets to panel to provide added stability to panels and eliminate the need for return panels.

▶ See page 649

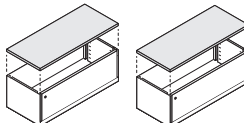

Wood veneer with square edge profile Laminate with square edge profile

Field-installed tops are available in two choices—wood veneer with square edge profile or laminate with square edge profile. Tops can be used on an individual lateral file, or larger tops can be used to connect files to make a credenza.

▶ Page 652

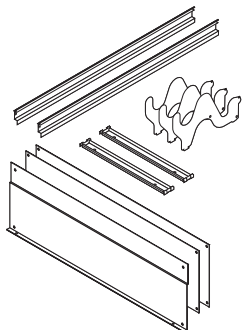

Field-installed accessories are available, including drawer accessories and counterweight packages.

▶ Page 655

Surface Materials

Lateral, including steel top, fixed shelf, and integral pulls

- Paint

Contemporary, handle, jazz, and bar pulls

- 0835 Black
- 9201 Polished Chrome
- 9211 Nickel
- 9212 Silver

cs:cape pull

- 4140 Arctic White Gloss
- 4144 Black Gloss
- 4799 Platinum Metallic

Wood veneer top, lift-up door, and drawer front

- Wood veneer—Open pore finishes
- Customiz stain (option)
- Full-fill finish (option) is available on field-installed wood veneer tops only. *Tip: Specify file with no top option.*

Laminate top, lift-up door, and drawer fronts

- Laminate
- Open Line laminate (option)

Lock

- 9201 Polished Chrome
- 9250 Ember Chrome (option)

Drawer bodies, hanging folder bars, rails, and dividers

- Black

Cushion top

- Fabric
- Leather

Basic cushion enhanced

- Fabric
- Tip: For both cushion top and basic cushion enhanced: fabric patterns with a linear design will always be applied from the front to back of the unit or the depth of the unit. Pattern matching will not be done on COM.*

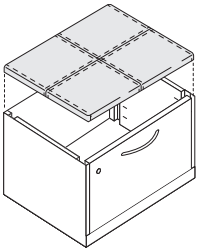

Cushion top will be manufactured in a four seam pattern in all standard solid color seating upholstery, leather, vinyls, COM leathers, and COM vinyls. These upholsteries are:

- Brisa
- Buzz2
- Cogent: Connect
- Dovetail by Designtex
- Era
- Elmosoft Leather
- Foundation
- Gaja
- Café Leather
- Leather
- Select Surfaces leather
- SoftNext
- Stand In
- Vinyl

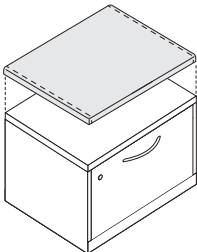

Cushion top will be manufactured in a two seam pattern for all approved standard patterned seating upholstery, leather, vinyl, COM leathers, and COM vinyls. All approved standard textured upholsteries will also be manufactured in a two seam pattern including leather, vinyl, COM leathers, and COM vinyls.

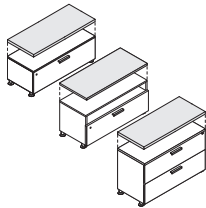

Basic cushion enhanced will be manufactured in a two seam pattern for all approved standard seating upholstery and Customer's Own Materials (COMs).
Note: Leathers and vinyls are not approved for basic cushion enhanced.

Application Topics

Storage Capacities and Dimensions

▶ See *Storage Specification Guide*

Counterweight Requirements for Storage Products

▶ Pages 265–272

Shipping

Lateral files are normally shipped in heavy-duty, recyclable stretch wrap to reduce the amount of corrugated board needed.

Counterweight packages ship separately from case and must be field-installed.

Universal Towers

Towers provide storage of a variety of work and personal items for an individual, including paper, binders, books, and coats.

► Specifying, page 628

Finished back is standard.

Interior of tower is available in a variety of configurations combining coat storage, fixed and adjustable shelves, and file drawers.

Pull on flush-front tower is integral and full height on doors and full width on drawers.

Locks are standard on door and drawers. Locks are standard factory-installed, keyed random. Door and drawer locks are keyed alike.

► *Lock and Keying*, page 686

Three base options are available: the universal 3" base, FrameOne foot, and c:scape glide. All three bases have the same overall height. All other universal towers are available with the universal 3" base only.

Drawers open their full depth for total access to the contents.

Leveling glides adjust up to 3/4" for universal 3" base and up to 1" for c:scape glide and FrameOne foot base to install tower on uneven floors.

Top is standard 1"H steel. Other top options are available.

Door is available in steel, laminate, or wood veneer. Hinges are European-style and allow doors to open to 110° for full access to the interior. Door is available hinged on left or right.

Locker space is 9" wide and standard with a coat rod.

Pull on proud-front tower is available in a variety of shapes.

Drawer fronts are available in steel, laminate, or wood veneer.

Product Details

Base options



Universal 3" Base



c:scape Glide Base



FrameOne Foot Base

All base options have same overall height. FrameOne foot base and c:scape glide base are only available on 18"D and 24"D openside towers.

Tip: Power infeed sits proud of the panel approximately 3" and will interfere with Universal storage with the Universal 3" base, FrameOne foot base, or c:scape glide.

Actual Dimensions

Depth with Flush Steel Front 18", 23 1/8", and 29 1/8"

Depth with Proud Steel, Laminate, or Wood Front 18 7/8", 24", and 30"

Width 24"

Height 47 1/2", 52", and 65 1/2"

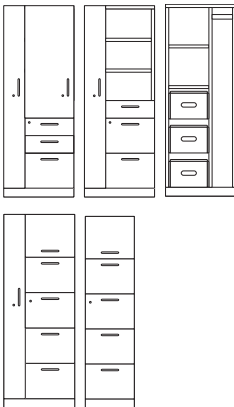

Interior of tower combines coat storage, box and file drawers, fixed and adjustable shelves.

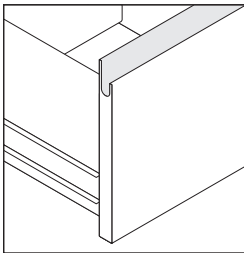

Flush-front pull is integral and full height on the door and full width on the drawers. Pull is available on steel doors and drawers only.

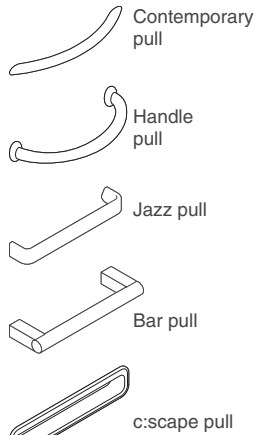

Proud-front pulls are available in the following styles—contemporary, handle, jazz, and bar. Door pull is 192 mm and drawer pulls are 128 mm. Proud-front pulls are available on steel, laminate, or wood veneer doors and drawers. c:scape pulls (200mm) are available on steel only.

Adjustable shelves on 52"H and 65½"H open side towers are recessed from the front and side of the tower. Shelves adjust in 2½" vertical increments. Opening on 47½"H tower is 13½"H and does not come with an adjustable shelf.

Post on open side towers supports adjustable shelves and is painted to match the case.

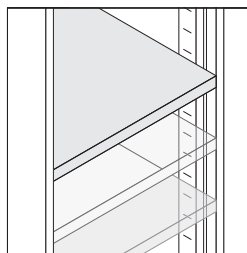

Adjustable shelves in dual door can be positioned in the interior of the tower in ¾" vertical increments using a reversible bracket. The first shelf above a file drawer is a fixed shelf.

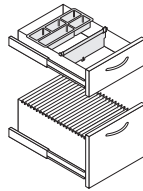

Drawer accessories include one divider and one pencil tray in each box drawer. File drawers can accommodate front-to-back filing of letter-size hanging folders without the use of additional accessories.

Safety interlock system allows only one drawer to be opened at a time.

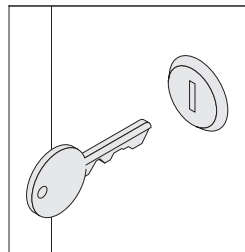

Locks are available factory- or field-installed. Factory-installed locks are standard and available keyed random only. Door and drawer locks are keyed alike. Optional field-installed locks are available with consecutive, specific, and random keying options. Master-keyed locks are also available. Field-installed lock cylinders must be specified separately.

► *Lock and Keying*, page 686

Drawer lock in open side tower is located in the top file drawer.

Drawer lock in dual door tower is located approximately 36" from the floor and also secures the lift-up door on 65½"H units.

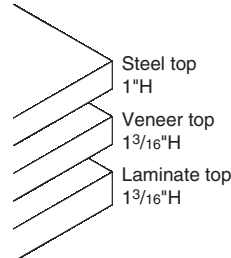

Laminate and wood veneer tops with square-edge profiles are available in place of standard 1"H steel tops. Laminate and wood veneer tops are ¾" taller than steel tops and will add that dimension to the overall height of the tower.

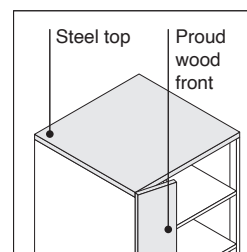

Top will default to steel on towers with proud wood fronts since the door overlaps and partially conceals the top. Wood top is available as an option.

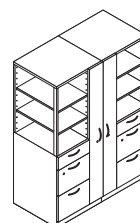

Ganging hardware is included to provide alignment by joining adjacent components side-by-side, back-to-back, or both.

Counterweight packages are required to ensure product stability and are ordered as an option or separately. Product specification pages indicate the correct counterweight package for each style number and any exceptions where counterweights are not required.

Connections

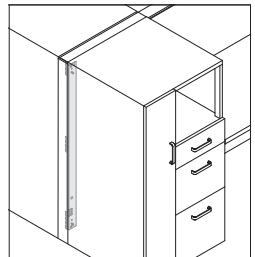

High strength to panel connector provides added stability to panels and eliminates the need for return panels.

► See page 649

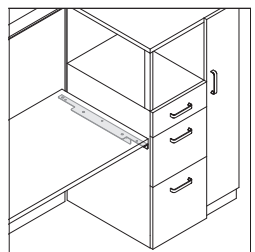

Worksurface to tower connector eliminates the need for other worksurface supports such as legs or end supports next to the tower.

► See page 648

Worksurface to tower alignment. Proud front towers align with 23½"D, 24"D, 29½"D, and 30"D worksurfaces. Flush front towers extend 7/8" beyond 24"D and 30"D worksurfaces, and 1/8" beyond 23½"D and 29½"D worksurfaces.

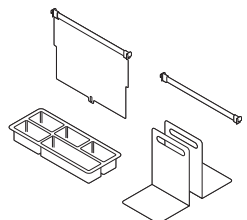

Field-installed accessories are available, including drawer accessories and shelf bookends.

► Page 655

Universal Towers, continued

Floor anchor bracket (for TS Series Storage and Universal Storage with 3" base) secures lateral files, towers, cabinets, or bookcases to the floor for stability or to reduce the risk of hazards during earthquakes in seismic zones. Four bracket packages are required for each cabinet. *Note: Local seismic requirements vary. Compliance with local code requirements is the responsibility of the customer or their authorized agent. For a California Office of Statewide Health Planning and Development (OSHPD) approved anchor bracket, contact Steelcase Specials.* *Tip: Anchor bracket cannot be used with pedestals.*

▶ Page 661

Surface Materials

Tower, including steel top, hinged door, integral pulls, drawer fronts, and adjustable shelves

- Paint

Post

- Paint to match tower (default)

Contemporary, handle, jazz, and bar pulls

- 0835 Black
- 9201 Polished Chrome
- 9211 Nickel
- 9212 Silver

c:scape pull

- 4140 Arctic White Gloss
- 4144 Black Gloss
- 4799 Platinum Metallic

Wood veneer top, hinged doors, and drawer fronts

- Wood veneer—
Open pore finishes
- Customiz stain (option)

Laminate top, hinged doors, and drawer fronts

- Laminate
- Open Line laminate (option)

Glass adjustable shelves

- Frosted tempered glass

Lock

- 9201 Polished Chrome
- 9250 Ember Chrome (option)

Drawer bodies, pencil tray, and box drawer divider

- Black

Coat rod

- Black with black supports

Application Topics

Storage Capacities and Dimensions

▶ See *Storage Specification Guide*

Counterweight Requirements for Storage Products

▶ Pages 265–272

Shipping

Towers are normally shipped in heavy-duty, recyclable stretch wrap to reduce the amount of corrugated board needed.

Counterweight packages ship separately from case and must be field installed.

Connectors

Worksurface-to-Tower Connectors

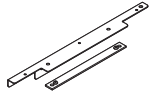

► Specifying page 648

Tip: Cannot be used with Currency storage.

Product Details

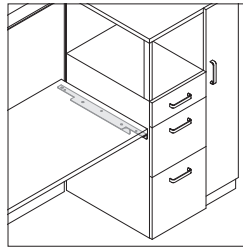

Connects worksurface to tower eliminating the need for other worksurface supports such as legs or end supports next to the tower.

► See *Application Rules for Panel Stability*, page 140.

Tip: When used with TS Series Tower Too in Answer applications, worksurface must be placed at 28½" height (floor to top of worksurface).

Tip: When using the work-surface-to-tower connector, the depth of the worksurface must match the depth of the tower.

Worksurface-to-tower connectors only support 24"D or 30"D (full depth and ½" cord drop) worksurfaces.

Surface Materials

Connector

- Paint

Actual Dimensions

Depth: 20", 26"

Storage-to-Panel Connectors

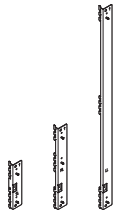

► Specifying page 649

Tip: For use with universal steel storage only.

Product Details

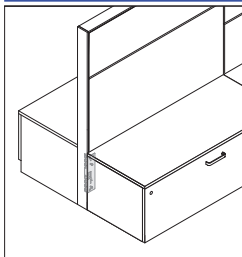

Low storage-to-panel connector connects One-High laterals and cabinets to panel to provide added stability to panels and eliminate the need for return panels.

Overhead storage or panels over 48"H can not be used in conjunction with low storage-to-panel connector.

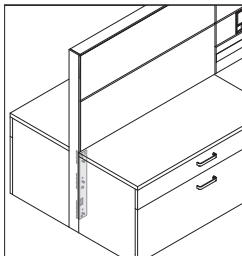

Medium storage-to-panel connector connects 1.5-High, 2-High, 3-High laterals and cabinets to panels to provide added stability to panels and eliminate the need for return panels.

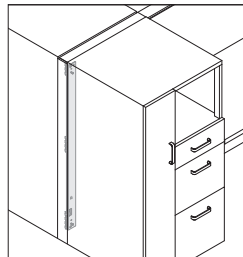

Tall storage-to-panel connector connects towers to panels to provide added stability to panels and eliminate the need for return panels. Tall storage-to-panel connector can be used with 48"H, 4-high, and 5-high towers.

Tall storage-to-panel connectors can only be used on 48"H or taller panels.

Note: Medium storage-to-panel connectors can be used on towers connected to panels shorter than 48"H, but must follow application guidelines for medium connectors.

Application Topics

Storage-to-panel connector can be positioned on the back or side of the cabinet. Connector must be located only on the ends of the back or side of the cabinet. It cannot be positioned anywhere else on the case side or back.

Storage-to-panel connectors can only be used with select storage products:
 –Universal lateral files and towers manufactured on or after November 2005
 –TS Series Tower Too manufactured on or after January 2009.

Surface Materials

Connector
 • Black paint only

Actual Dimensions

Height: 8¾", 16", 39⅝"

Understanding High-Density Storage Products



Statement of Line **308**



High-Density Storage **310**

High-Density Storage—Value Package **312**

Statement of Line

High-Density Storage Products

24" or 30"D

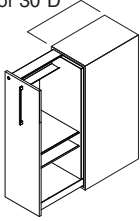

Understanding
▶ Page 310
Specifying
▶ Page 640

High-Density Storage

	12"W	15"W
42"H	●	●
48"H	●	●

24" or 30"D

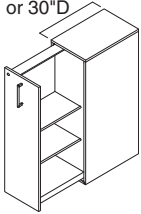

Understanding
▶ Page 312
Specifying
▶ Page 644

High-Density Storage—Value Package

	12"W	15"W
42"H	●	●
48"H	●	●

High-Density Storage

High-density storage is a personal storage product that provides ample organizational space with the added benefit of extendable privacy. Two configurations are available, shelf and bag drop. Resident workers are supported with room for their piles, files, and supplies to support their work flow in the high-density storage with shelf versions. Mobile workers have temporary storage and ease of access for all their belongings in the high-density storage with bag drop versions.

► Specifying, page 640

Front is available in laminate or veneer.

Contrasting front is available as an option.

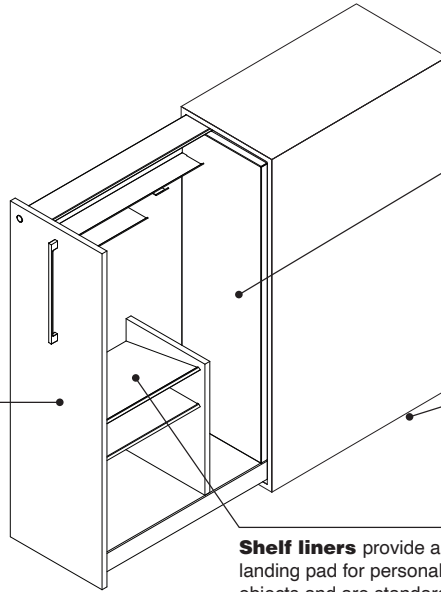

Coat closet, available as an option, is 7"W on 24"D units and 8"W on 30"D units and standard with two coat hooks.

Leveling glides adjust to install case on uneven floors and have a 1/2" adjustable range.

Shelf liners provide a soft landing pad for personal objects and are standard in the bag drop configuration.

Locks are standard on door. Locks are standard factory-installed, keyed random.
► *Lock and Keying*, page 686

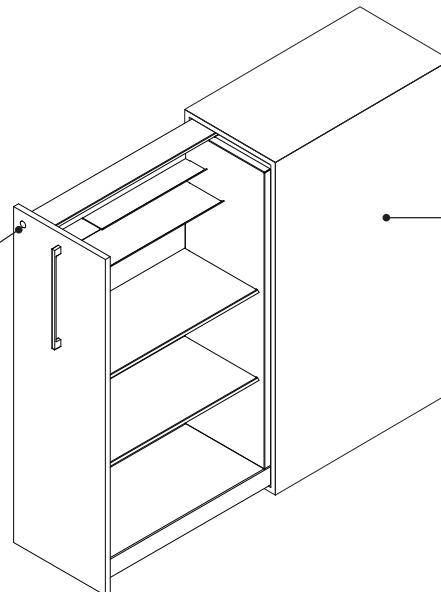

Case is available in laminate or veneer.

Product Details

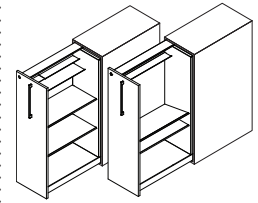

Two configurations are available on the 15"W version, the shelf configuration or the bag drop configuration. Only the shelf configuration is available on the 12"W version.

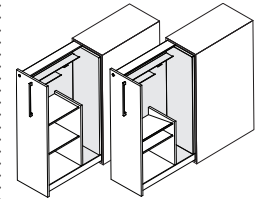

Coat closet is available as an option.

Left-hand configuration

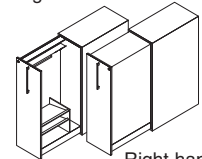

Right-hand configuration

Left-hand and right-hand configurations are available.

Mirrors are standard in all cases.

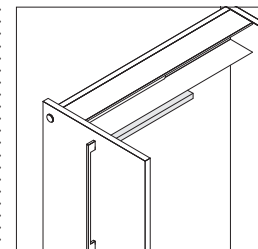

Light is available as an option on the bag drop configuration only.

Actual Dimensions

Depth 24" and 30"

Width 12" and 15"

Height 42" and 48"

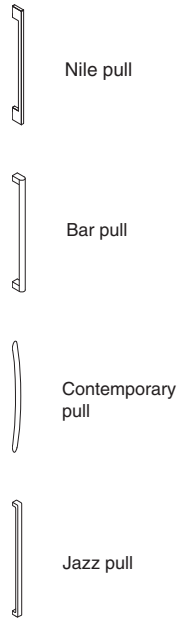

Nile pull

Bar pull

Contemporary pull

Jazz pull

Pull on high-density storage defaults with a Nile pull. Bar, contemporary, and jazz pull are available as an option.

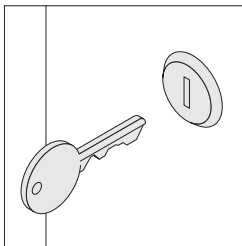

Locks are available factory- or field-installed. Factory-installed locks are standard and available keyed random only. Optional field-installed locks are available with consecutive, specific, and random keying options. Master-keyed locks are also available. Field-installed lock cylinders must be specified separately.

▶ *Lock and Keying*, page 686

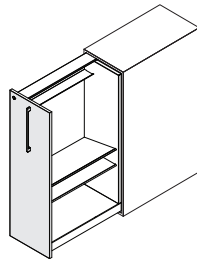

Contrasting fronts and horizontal grain direction are available options for laminate front/laminate case, veneer front/laminate case, or laminate front/veneer case.

Application Topics

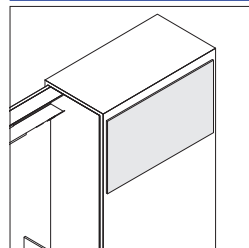

Magnetic boards, available as an option, are fabric-wrapped steel providing a place for visual display. The size of the magnetic board is determined by high-density case height and depth. Magnetic boards are field installed.
Tip: Magnetic board is not available on 12"W unit.

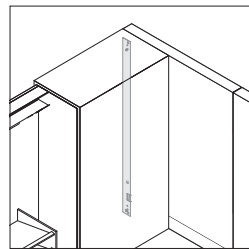

Panel connector bracket is available to connect to an Answer panel. Connector bracket provides added stability to panels and eliminates the need for return panels.

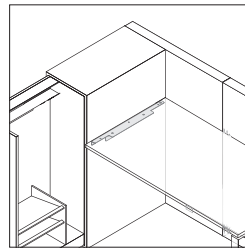

Worksurface support bracket can be used to mount a worksurface off one side of the high-density storage eliminating the need for other worksurface supports such as legs or end supports next to the case.

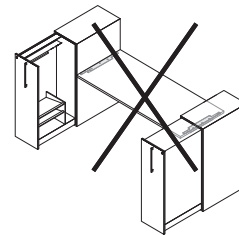

Worksurface support bracket can be used to support one side of a worksurface only.

Surface Materials

Case, including front

- Laminate
- Veneer

Case interior and worksurface support bracket

- Paint

Shelf

- 7360 Merle

Contemporary, jazz, and bar pulls

- 9201 Polished Chrome
- 9211 Nickel
- 9212 Silver

Nile pulls

- 0835 Black
- 4799 Platinum Metallic
- 7280 Smooth Bronze
- 9201 Polished Chrome
- 9211 Nickel

Magnetic board

- Cogent: Connect
- Billiard Multi-Use by DesignTex

Panel connector bracket

- 0835 Black

Lock

- 9201 Polished Chrome
- 9250 Ember Chrome (option)

Application Topics

Storage Capacities and Dimensions

▶ See *Storage Specification Guide*.

Counterweight Requirements for Storage Products

▶ See *Storage Specification Guide*.

Shipping

High-density storage is normally shipped in heavy-duty, recyclable stretch wrap to reduce the amount of corrugated board needed.

High-Density Storage—Value Package

The high-density storage value package is a simplified configuration of high-density storage that solves organizational needs at a lower pricepoint. It is available with a laminate case with steel interior and limited specification options.
 ▶ Specifying, page 644

Locks are standard on door. Locks are standard factory-installed, keyed random.
 ▶ *Lock and Keying*, page 686

Front is laminate.

Contrasting front is available as an option.

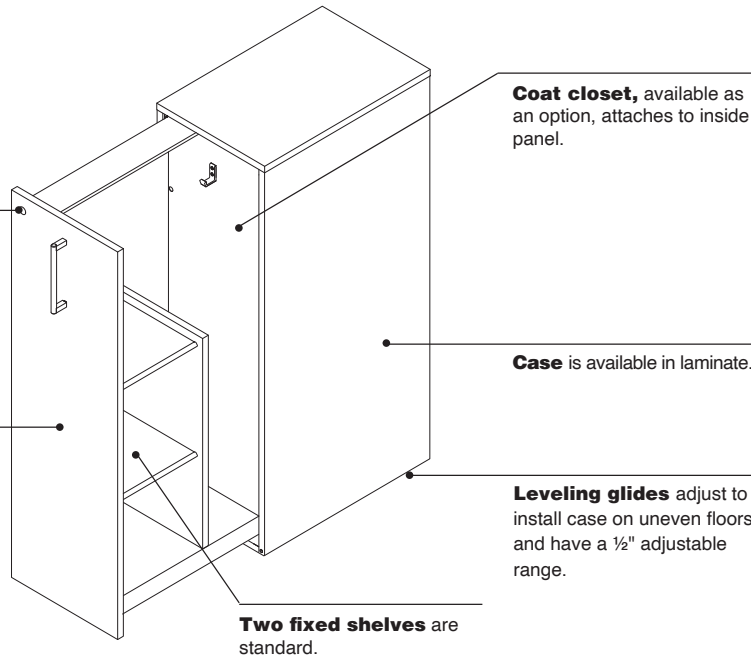

Product Details

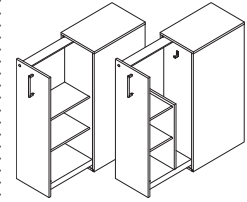

Coat closet is available as an option.
Tip: Coat hook is unique to the value package and will be visually different than in high-density storage.

Left-hand and right-hand configurations are available.

Value package does not include mirror, lock cover, or upper shelves found in high-density storage units.

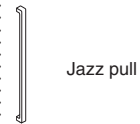
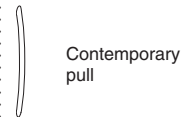
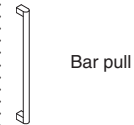
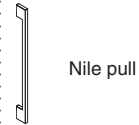

Pull on high-density storage defaults with a Nile pull. Bar, contemporary, and jazz pull are available as an option.

Actual Dimensions

Depth 24" and 30"

Width 12" and 15"

Height 42" and 48"

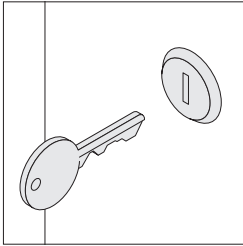

Locks are available factory- or field-installed. Factory-installed locks are standard and available keyed random only. Optional field-installed locks are available with consecutive, specific, and random keying options. Master-keyed locks are also available. Field-installed lock cylinders must be specified separately.

▶ *Lock and Keying*, page 686

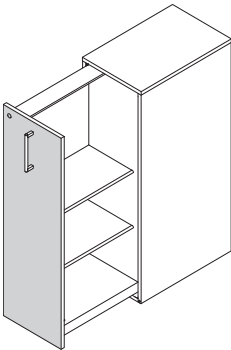

Contrasting fronts and horizontal grain direction are available options.

Application Topics

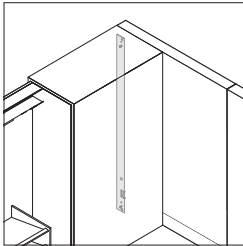

Panel connector bracket is available to connect to an Answer panel. Connector bracket provides added stability to panels and eliminates the need for return panels.

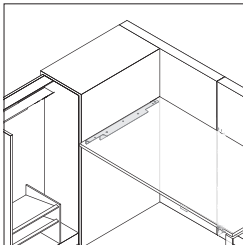

Worksurface support bracket can be used to mount a worksurface off one side of the high-density storage eliminating the need for other worksurface supports such as legs or end supports next to the case.

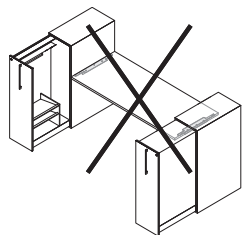

Worksurface support bracket can be used to support one side of a work surface only.

Surface Materials

Case, including front

- Laminate

Case interior and worksurface support bracket

- Paint

Shelf

- 7360 Merle

Contemporary, jazz, and bar pulls

- 0835 Black
- 9201 Polished Chrome
- 9211 Nickel
- 9212 Silver

Nile pulls

- 0835 Black
- 4799 Platinum Metallic
- 7280 Smooth Bronze
- 9201 Polished Chrome
- 9211 Nickel

Panel connector bracket

- 0835 Black

Lock

- 9201 Polished Chrome
- 9250 Ember Chrome (option)

Application Topics

Storage Capacities and Dimensions

▶ See *Storage Specification Guide*.

Counterweight Requirements for Storage Products

▶ See *Storage Specification Guide*.

Shipping

High-density storage is normally shipped in heavy-duty, recyclable stretch wrap to reduce the amount of corrugated board needed.



Understanding Duo Storage Products

Statement of Line **316**

Duo Tall Storage **318**
Stability Guidelines **320**

Statement of Line

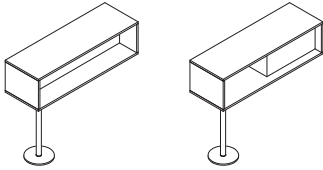

Understanding
▶ Page 318
Specifying
▶ Page 664

Duo Tall Storage

15"H

54"W ●

66"W ●

78"W ●

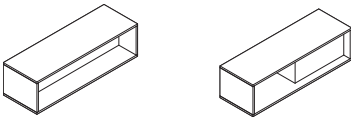

Understanding
▶ Page 318
Specifying
▶ Page 665

Duo Tall and Slim Storage (For Use with Answer Top Cap Mounted Storage)

Tall Individual

Tall Shared

54"W ●

●

66"W ●

●

Duo Tall Storage

Duo tall storage can be used to attach to Answer in-line, L,T, and end-of-run junctions.

Panel stabilizer

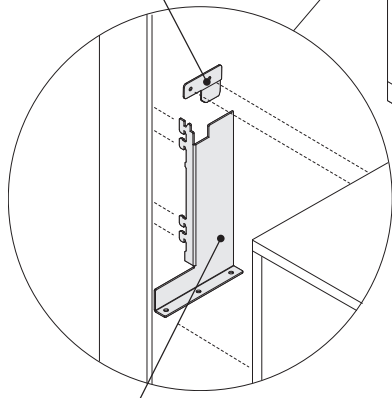

Panel bracket connects box into panel junction slots.

Duo tall storage can be used to attach to the top of Answer panels with thin trim. Attachment brackets and trims are sold separately.

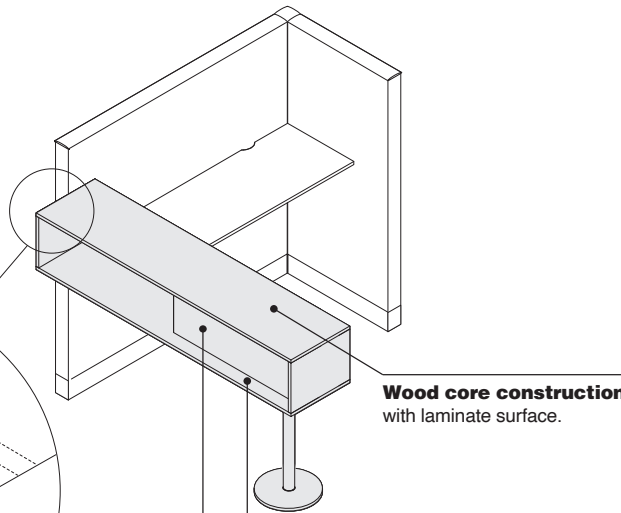
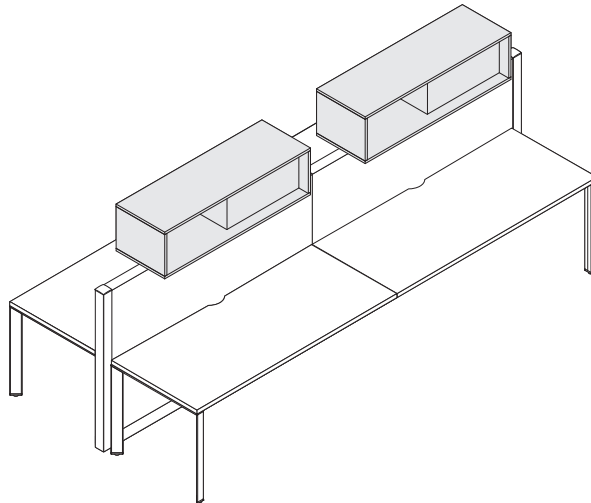

Wood core construction with laminate surface.

Ledge provides support for office supplies.

Magnets can be used to display items on painted steel divider cover.

Product Details

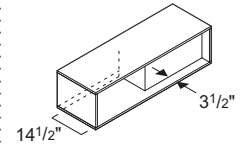
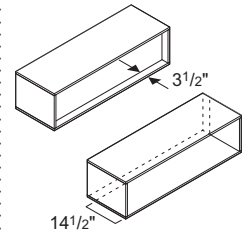

Two interior configurations of Tall Storage are available. Individual box has a ledge on one side and space for binder storage on the opposite side. Shared box is divided down the center with half ledge and half binder storage on each side.

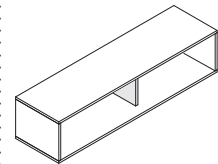

66"W and 78"W individual boxes have a center divider on the binder storage side for additional support.

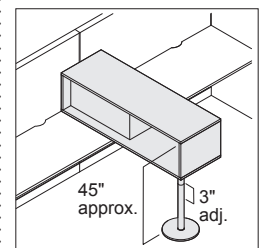

Column height at shortest level is 29⁷/₈"H. Column will then adjust upward 3" for leveling.

Height from floor to top of box is approximately 45".

Actual Dimensions

Tall Storage

Box exterior height	15"
Box exterior depth	18"
Box exterior width	54", 66", and 78"
Box interior height	13 ³ / ₈ "
Box interior depth	13 ⁵ / ₈ " (binder storage area)
Box interior depth (ledge)	3 ¹ / ₂ "
Box interior width	52 ³ / ₈ ", 64 ³ / ₈ ", and 76 ³ / ₈ "
Leg height	29 ⁷ / ₈ "

Connections

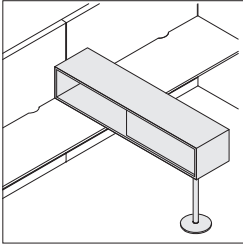

Attaches perpendicular (90°) to Answer panel at in-line, end-of-run, L or T junction. Works with 42"H or taller panels only. Attaches on-module only.

Panel-mounted work-surfaces are required when connecting Duo Tall Storage to Answer panels at an in-line, L, T, or end-of-run junction. Worksurface brackets are included to attach to Duo Tall Storage worksurfaces to improve stability.

In seismic zones 3 and 4, consult with local building code officials for specific code requirements applicable to your installation.

Duo Tall cannot be installed with case in front of slatwall skin.

When mounting Duo Tall Storage on top of an Answer panel, top cap mounting brackets and additional panel top caps will need to be specified separately.

▶ Page 372

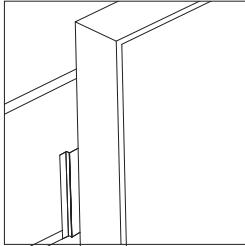
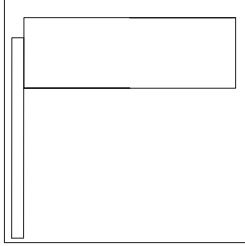

For right-handed Duo end-of-run configurations, the panel bracket will be visible.

Surface Materials

Box

- Laminate

Interior divider cover

- Paint

Brackets and leg

- 4799 Platinum paint

Stability Guidelines

Stability Guidelines for Answer and Duo Tall Storage

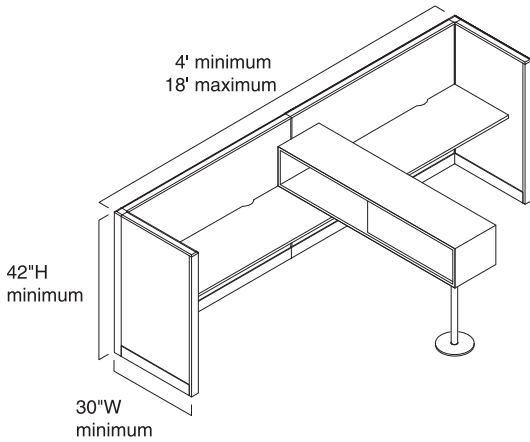

Duo Tall Storage cannot be mounted off-module.

A minimum 30"W Answer panel return at 90° or 36"W at 120° must be used with Duo Tall Storage.

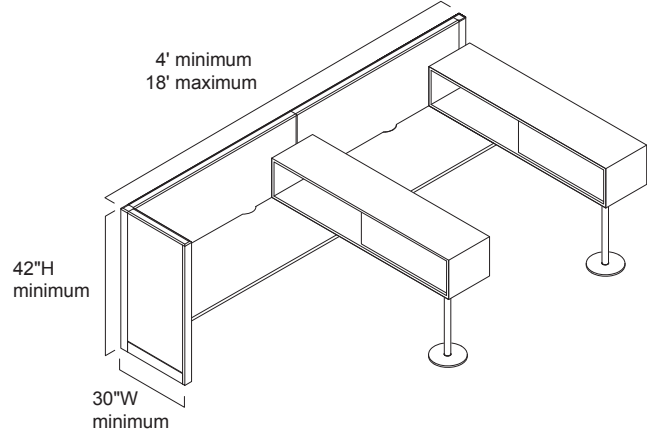

If Duo Tall Storage is mounted in an end-of-run application, a 30"W minimum panel return must be used on the other end of the run.

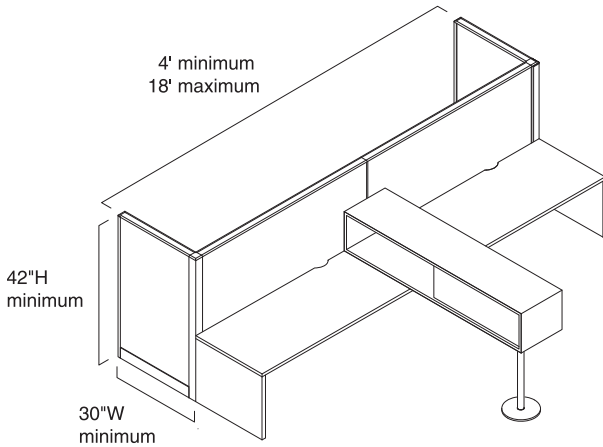

Duo Tall Storage cannot be mounted off-module.

A minimum 30"W Answer panel return at 90° or 120° must be used with Duo Tall Storage.

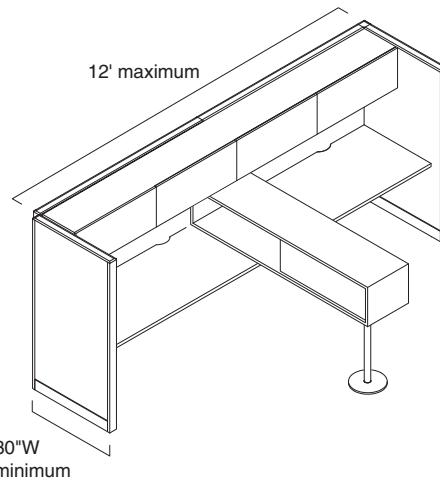

A 30"W minimum panel return is required when Duo Tall Storage is used on a panel that is supporting additional components.

Stability Guidelines for Duo Tall Storage-to-Answer Panel Application in Seismic Zones

- Follow traditional planning guidelines.
- Tall Storage leg base must be bolted to the floor per local building code.
- Worksurface brackets included must be installed.

Specifying Panels—Thin Trim

In-Line Base Panel Junctions—Thin Trim	322	Build Your Own Junction Components—Thin Trim	356
L and T Same Height Base Panel Junctions—Thin Trim	323	Base Horizontal Frame Packages—Thin Trim and Big Open Base Trim Package	360
X Same Height Base Panel Junctions—Thin Trim	324	Stacking Horizontal Frame Packages	362
End-of-Run Base Panel Junctions—Thin Trim	325	Spanning Top Caps—Thin Trim	363
V and Y Same Height Base Panel Junctions—Thin Trim	326	Frameless Glass Screens with Recessed Attachment—Thin Trim	364
In-Line Change-of-Height Junctions—Thin Trim	327	Recessed Frameless Glass Top Cap Connector—Thin Trim	367
L Change-of-Height Junctions—Thin Trim	328	Junction Grommets for Frameless Glass—Thin Trim	367
T Change-of-Height Junctions—Thin Trim	330	Frameless Glass Screens with Clip Attachment—Thin Trim	368
X Change-of-Height Junctions—Thin Trim	334	Universal and Sarto Screens with Answer Thin Trim Top Cap	370
V Change-of-Height Junctions—Thin Trim	338	Top Cap Mount Storage	372
Y Change-of-Height Junctions—Thin Trim	340	Panel Packages—Thin Trim	374
Wall-Start Junctions	342	Answer Boundary Screens	376
Brackets	343	Base Trims and Open Base Conversion Kits	399
Off-Module Panel Connectors	344		
Stacking In-Line Panel Junctions—Thin Trim	345		
Stacking End-of-Run Panel Junctions—Thin Trim	345		
Stacking Wall-Start Junctions	345		
Stacking L, T, X, V, and Y Panel Junctions—Thin Trim	346		
Utility Pole—L,T, and X—Thin Trim	347		
Utility Packages	348		
End-of-Run Vertical Trims—Thin Trim	350		
L and T Vertical Trims—Thin Trim	351		
V Vertical Trims—Thin Trim	352		
End-of-Run/In-Line Change-of-Height Trims—Thin Trim	353		
90° Corner Application Change-of-Height Trims—Thin Trim	354		
120° Corner Application Change-of-Height Trims—Thin Trim	355		

In-Line Base Panel Junctions—Thin Trim



Tip: In-line base panel junctions do not require junction cap and trim.

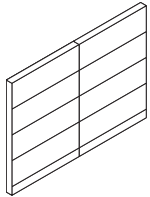

Standard Includes	Required to Specify
<ul style="list-style-type: none"> ▶ Need help? Product details, page 20 • Junction • Aligner 	<ul style="list-style-type: none"> Style number

Specification Information		
Corresponding Panel Height	Style Number	U.S. Price
30"	TS730TIPJ	\$110
36"	TS736TIPJ	\$110
42"	TS742TIPJ	\$110
48"	TS748TIPJ	\$110
54"	TS754TIPJ	\$110
66"	TS766TIPJ	\$110
78"	TS778TIPJ	\$155
:	:	:



For Canadian Pricing
 Multiply U.S. Price by the Canadian price factor.
 ▶ See page 1 for details.

L and T Same Height Base Panel Junctions—Thin Trim

L and T Same Height Base Panel Junctions—Thin Trim

Standard Includes		Required to Specify
<ul style="list-style-type: none"> ▶ Need help? Product details, page 20 	<ul style="list-style-type: none"> • Junction • Inside corner light seal(s) • Vertical trim and junction cap on L and T junction: paint price group 1 or wood group 1 • Aligner(s) 	<ul style="list-style-type: none"> 1 Style number 2 Paint or wood color number for trim and junction cap 3 Options, if selected (see below) ▶ See <i>Surface Materials</i>, page 668.

Options	U.S. Price	Required to Specify
Surface Materials Trim <ul style="list-style-type: none"> • Paint price group 1 • Paint price group 2 • Paint price group 3 	No cost +\$16 +\$34	Specify paint color number. Specify paint color number. Specify paint color number.
<ul style="list-style-type: none"> • Customiz stain on wood • Omit trim 	No cost Prices below	Specify with <i>Customiz stain</i> . Specify with <i>omit trim</i> .

Tip: Omit trim option is used when stacking on base panel junctions. Vertical trim should be specified separately to span the full height of the base panel junction plus the stacking junction.

Tip: Remember to specify necessary junction cap and aligners if the omit trim option is selected.

Specification Information

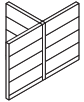
L Base Panel Junctions with Thin Trim			T Base Panel Junctions with Thin Trim			
						
Corresponding Panel Height	Style Number	U.S. Base Price	Option (Add \$ to Base Price)	Style Number	U.S. Base Price	Option (Add \$ to Base Price)
			Omit Trim			Omit Trim

Painted Trim

Height	Style	U.S. Price	Option	Style	U.S. Price	Option
30"	TS730TLPJ	\$242	-\$ 98	TS730TTPJ	\$242	-\$ 98
36"	TS736TLPJ	\$242	-\$ 98	TS736TTPJ	\$242	-\$ 98
42"	TS742TLPJ	\$242	-\$ 98	TS742TTPJ	\$242	-\$ 98
48"	TS748TLPJ	\$242	-\$ 98	TS748TTPJ	\$242	-\$ 98
54"	TS754TLPJ	\$242	-\$ 98	TS754TTPJ	\$242	-\$ 98
66"	TS766TLPJ	\$242	-\$ 98	TS766TTPJ	\$242	-\$ 98
78"	TS778TLPJ	\$338	-\$120	TS778TTPJ	\$338	-\$120

Wood Trim

Height	Style	U.S. Price	Option	Style	U.S. Price	Option
30"	TS730TLPJW	\$655	-\$461	TS730TTPJW	\$655	-\$461
36"	TS736TLPJW	\$655	-\$461	TS736TTPJW	\$655	-\$461
42"	TS742TLPJW	\$655	-\$461	TS742TTPJW	\$655	-\$461
48"	TS748TLPJW	\$655	-\$461	TS748TTPJW	\$655	-\$461
54"	TS754TLPJW	\$655	-\$461	TS754TTPJW	\$655	-\$461
66"	TS766TLPJW	\$671	-\$461	TS766TTPJW	\$671	-\$461
78"	TS778TLPJW	\$829	-\$550	TS778TTPJW	\$829	-\$550

 **For Canadian Pricing**
 Multiply U.S. Price by the Canadian price factor.
 ▶ See page 1 for details.

X Same Height Base Panel Junctions—Thin Trim

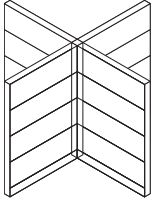

Tip: Omit trim option is used when stacking on base panel junctions.

Tip: Remember to specify necessary junction cap and aligners if the omit trim option is selected.

Standard Includes		Required to Specify
<ul style="list-style-type: none"> ▶ Need help? Product details, page 20 	<ul style="list-style-type: none"> • Junction • Inside corner light seals • Trim/junction cap: paint or wood group 1 • Aligners 	<ul style="list-style-type: none"> 1 Style number 2 Paint or wood color number for junction cap 3 Options, if selected (see below) ▶ See <i>Surface Materials</i>, page 668.

Options	U.S. Price	Required to Specify
Surface Materials <ul style="list-style-type: none"> • Paint price group 1 • Paint price group 2 • Paint price group 3 	<ul style="list-style-type: none"> No cost +\$16 +\$34 	<ul style="list-style-type: none"> Specify paint color number. Specify paint color number. Specify paint color number.
<ul style="list-style-type: none"> • Customiz stain on wood • Omit trim 	<ul style="list-style-type: none"> No cost Prices below 	<ul style="list-style-type: none"> Specify with <i>Customiz stain</i>. Specify with <i>omit trim</i>.

Specification Information			
Corresponding Panel Height	Style Number	U.S. Base Price	Option (Add \$ to Base Price) Omit Trim

Painted Trim

30"	TS730TXPJ	\$242	-\$ 17
36"	TS736TXPJ	\$242	-\$ 17
42"	TS742TXPJ	\$242	-\$ 17
48"	TS748TXPJ	\$242	-\$ 17
54"	TS754TXPJ	\$242	-\$ 17
66"	TS766TXPJ	\$242	-\$ 17
78"	TS778TXPJ	\$338	-\$ 17

Wood Trim

30"	TS730TXPJW	\$339	-\$108
36"	TS736TXPJW	\$339	-\$108
42"	TS742TXPJW	\$339	-\$108
48"	TS748TXPJW	\$339	-\$108
54"	TS754TXPJW	\$339	-\$108
66"	TS766TXPJW	\$339	-\$108
78"	TS778TXPJW	\$437	-\$108



For Canadian Pricing
 Multiply U.S. Price by the Canadian price factor.
 ▶ See page 1 for details.

End-of-Run Base Panel Junctions—Thin Trim



Tip: End-of-run trim adds 1/2" to footprint.

Tip: Omit trim option is used when stacking on base panel junctions. Vertical trim should be specified separately to span the full height of the base panel junction plus the stacking junction.

Standard Includes	Required to Specify
<ul style="list-style-type: none"> ▶ Need help? Product details, page 20 • Junction • Trim on end-of-run junction: paint price group 1 or wood group 1 • Aligner 	<ul style="list-style-type: none"> 1 Style number 2 Paint or wood color number for trim 3 Options, if selected (see below) ▶ See <i>Surface Materials</i>, page 668.

Surface Materials	Options	U.S. Price	Required to Specify
	Trim <ul style="list-style-type: none"> • Paint price group 1 • Paint price group 2 • Paint price group 3 	No cost +\$16 +\$34	Specify paint color number. Specify paint color number.
	<ul style="list-style-type: none"> • Customiz stain on wood • Omit trim 	No cost Prices below	Specify with <i>Customiz stain</i> . Specify with <i>omit trim</i> .

Specification Information			
• Corresponding Panel Height	• Style Number	• U.S. Base Price	• Option (Add \$ to Base Price) • Omit Trim
•	•	•	•
•	•	•	•
•	•	•	•

Painted Trim

30"	TS730TEPJ	\$155	-\$ 82
36"	TS736TEPJ	\$155	-\$ 82
42"	TS742TEPJ	\$155	-\$ 82
48"	TS748TEPJ	\$155	-\$ 82
54"	TS754TEPJ	\$155	-\$ 82
66"	TS766TEPJ	\$155	-\$ 82
78"	TS778TEPJ	\$219	-\$106
•	•	•	•

Wood Trim

30"	TS730TEPJW	\$479	-\$355
36"	TS736TEPJW	\$479	-\$355
42"	TS742TEPJW	\$479	-\$355
48"	TS748TEPJW	\$479	-\$355
54"	TS754TEPJW	\$479	-\$355
66"	TS766TEPJW	\$479	-\$355
78"	TS778TEPJW	\$628	-\$445
•	•	•	•

For Canadian Pricing
 Multiply U.S. Price by the Canadian price factor.
 ▶ See page 1 for details.

V and Y Same Height Base Panel Junctions—Thin Trim



Standard Includes	Required to Specify
<ul style="list-style-type: none"> Need help? Product details, page 20 Junction Vertical trim and junction cap on V junction: paint price group 1 or wood group 1 Trim/junction cap on Y junction: paint price group 1 or wood group 1 Aligner(s) 	<ol style="list-style-type: none"> Style number Paint or wood color number for trim and junction cap Options, if selected (see below) <ul style="list-style-type: none"> ▶ See <i>Surface Materials</i>, page 668.

Options	U.S. Price	Required to Specify
Surface Materials Trim <ul style="list-style-type: none"> Paint price group 1 Paint price group 2 Paint price group 3 	No cost +\$16 +\$34	Specify paint color number. Specify paint color number. Specify paint color number.
<ul style="list-style-type: none"> Customiz stain on wood Omit trim 	No cost Prices below	Specify with <i>Customiz stain</i> . Specify with <i>omit trim</i> .

Tip: Omit trim option is used when stacking on base panel junctions. Vertical trim should be specified separately to span the full height of the base panel junction plus the stacking junction.

Tip: Remember to specify necessary junction cap and aligners if the omit trim option is selected.

Specification Information

V Base Panel Junctions with Thin Trim				Y Base Panel Junctions with Thin Trim		
						
Corresponding Panel Height	Style Number	U.S. Base Price	Option (Add \$ to Base Price) Omit Trim	Style Number	U.S. Base Price	Option (Add \$ to Base Price) Omit Trim

Painted Trim

30"	TS730TVPJ	\$ 367	-\$119	TS730TYPJ	\$367	-\$ 17
36"	TS736TVPJ	\$ 367	-\$119	TS736TYPJ	\$367	-\$ 17
42"	TS742TVPJ	\$ 367	-\$119	TS742TYPJ	\$367	-\$ 17
48"	TS748TVPJ	\$ 367	-\$119	TS748TYPJ	\$367	-\$ 17
54"	TS754TVPJ	\$ 367	-\$119	TS754TYPJ	\$367	-\$ 17
66"	TS766TVPJ	\$ 367	-\$119	TS766TYPJ	\$367	-\$ 17
78"	TS778TVPJ	\$ 507	-\$141	TS778TYPJ	\$507	-\$ 17

Wood Trim

30"	TS730TVPJW	\$ 796	-\$501	TS730TYPJW	\$469	-\$108
36"	TS736TVPJW	\$ 796	-\$501	TS736TYPJW	\$469	-\$108
42"	TS742TVPJW	\$ 796	-\$501	TS742TYPJW	\$469	-\$108
48"	TS748TVPJW	\$ 796	-\$501	TS748TYPJW	\$469	-\$108
54"	TS754TVPJW	\$ 796	-\$501	TS754TYPJW	\$469	-\$108
66"	TS766TVPJW	\$ 821	-\$501	TS766TYPJW	\$469	-\$108
78"	TS778TVPJW	\$1021	-\$594	TS778TYPJW	\$608	-\$108



For Canadian Pricing
 Multiply U.S. Price by the Canadian price factor.
 ▶ See page 1 for details.

In-Line Change-of-Height Junctions—Thin Trim

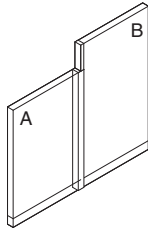

Tip: Junction includes:

- In-line base junction
- End-of-run stacking junction
- Stacking fork
- End-of-run change-of-height trim
- Aligner

Tip: Remember to specify a stacking horizontal frame package with this application, unless there is a window in the top position of the taller panel.

Tip: Omit trim option omits change-of-height trim. This option is used when stacking on base panel junctions. Change-of-height trims should be specified separately to span the full height of the base panel junction plus the stacking junction.

Standard Includes		Required to Specify
▶ Need help? Product details, page 24	<ul style="list-style-type: none"> • Junction • Change-of-height trim: paint price group 1 or wood group 1 • Aligner 	1 Style number 2 Paint or wood color number for trim ▶ See <i>Surface Materials</i> , page 668.

Options	U.S. Price	Required to Specify
Surface Materials		
Trim		
• Paint price group 1	No cost	Specify paint color number.
• Paint price group 2	+\$16	Specify paint color number.
• Paint price group 3	+\$34	Specify paint color number.
• Customiz stain on wood	No cost	Specify with <i>Customiz stain</i> .
• Omit trim	Prices below	Specify with <i>omit trim</i> .

Specification Information						
Corresponding Panel Height	Style Number	U.S. Base Price	Option (Add \$ to Base Price)	Style Number	U.S. Base Price	Option (Add \$ to Base Price)
A B			Omit Trim			Omit Trim

Painted Trim				Wood Trim			
30"	36"	TS73QTCIJ	\$281 -\$78	TS73QTCIJW	\$554	-\$280	
30"	42"	TS734TCIJ	\$281 -\$78	TS734TCIJW	\$554	-\$280	
30"	48"	TS738TCIJ	\$286 -\$78	TS738TCIJW	\$560	-\$280	
30"	54"	TS735TCIJ	\$292 -\$78	TS735TCIJW	\$567	-\$280	
30"	66"	TS736TCIJ	\$315 -\$82	TS736TCIJW	\$585	-\$284	
36"	42"	TS7Q4TCIJ	\$281 -\$78	TS7Q4TCIJW	\$554	-\$280	
36"	48"	TS7Q8TCIJ	\$286 -\$78	TS7Q8TCIJW	\$560	-\$280	
36"	54"	TS7Q5TCIJ	\$292 -\$78	TS7Q5TCIJW	\$567	-\$280	
36"	66"	TS7Q6TCIJ	\$315 -\$82	TS7Q6TCIJW	\$585	-\$284	
42"	48"	TS748TCIJ	\$281 -\$78	TS748TCIJW	\$554	-\$280	
42"	54"	TS745TCIJ	\$281 -\$78	TS745TCIJW	\$554	-\$280	
42"	66"	TS746TCIJ	\$292 -\$78	TS746TCIJW	\$567	-\$280	
42"	78"	TS747TCIJ	\$362 -\$82	TS747TCIJW	\$629	-\$284	
48"	66"	TS786TCIJ	\$286 -\$78	TS786TCIJW	\$560	-\$280	
48"	54"	TS785TCIJ	\$286 -\$78	TS785TCIJW	\$560	-\$280	
54"	66"	TS756TCIJ	\$281 -\$78	TS756TCIJW	\$554	-\$280	
54"	78"	TS757TCIJ	\$337 -\$78	TS757TCIJW	\$610	-\$280	
54"	90"	TS759TCIJ	\$416 -\$78	TS759TCIJW	\$687	-\$280	
66"	78"	TS767TCIJ	\$324 -\$78	TS767TCIJW	\$597	-\$280	
66"	90"	TS769TCIJ	\$403 -\$78	TS769TCIJW	\$675	-\$280	
78"	90"	TS779TCIJ	\$397 -\$78	TS779TCIJW	\$667	-\$280	

 **For Canadian Pricing**
 Multiply U.S. Price by the Canadian price factor.
 ▶ See page 1 for details.

L Change-of-Height Junctions—Thin Trim

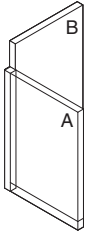

Tip: Junction includes:

- L change-of-height junction
- Inside corner light seal
- L vertical trim
- End-of-run change-of-height trim
- Change-of-height junction cap
- Aligners

Tip: Omit trim option omits all vertical and change-of-height trim. This option is used when stacking on base junctions.

Vertical and change-of-height trim should be specified separately to span the full height of the base junction plus the stacking junction.

Tip: Remember to specify necessary junction cap and aligners if the omit trim option is selected.

Tip: Change-of-height junction ships right-handed. For a left-handed junction a post will need to be moved during installation.

Standard Includes		Required to Specify
▶ Need help? Product details, page 24	<ul style="list-style-type: none"> • Junction • Inside corner light seal • Change-of-height trim and junction cap: paint price group 1 or wood group 1 • Aligner 	<ol style="list-style-type: none"> 1 Style number 2 Paint or wood color number for trim and junction cap 3 Options, if selected (see below) <p>▶ See <i>Surface Materials</i>, page 668.</p>

Surface Materials	Options	U.S. Price	Required to Specify
	Trim		
	<ul style="list-style-type: none"> • Paint price group 1 • Paint price group 2 • Paint price group 3 	No cost +\$16 +\$34	Specify paint color number. Specify paint color number. Specify paint color number.
	<ul style="list-style-type: none"> • Customiz stain on wood • Omit trim 	No cost Prices below	Specify with <i>Customiz stain</i> . Specify with <i>omit trim</i> .

Specification Information						
Corresponding Panel Height	Style Number	U.S. Base Price	Option (Add \$ to Base Price)	Style Number	U.S. Base Price	Option (Add \$ to Base Price)
A B			Omit Trim			Omit Trim

Painted Trim				Wood Trim			
30"	36"	TS73QTCLJ	\$331	-\$177	TS73QTCLJW	\$ 985	-\$741
30"	42"	TS734TCLJ	\$331	-\$177	TS734TCLJW	\$ 985	-\$741
30"	48"	TS738TCLJ	\$331	-\$177	TS738TCLJW	\$ 985	-\$741
30"	54"	TS735TCLJ	\$341	-\$177	TS735TCLJW	\$ 997	-\$741
30"	66"	TS736TCLJ	\$366	-\$180	TS736TCLJW	\$1026	-\$746
36"	42"	TS7Q4TCLJ	\$331	-\$177	TS7Q4TCLJW	\$ 985	-\$741
36"	48"	TS7Q8TCLJ	\$331	-\$177	TS7Q8TCLJW	\$ 985	-\$741
36"	54"	TS7Q5TCLJ	\$341	-\$177	TS7Q5TCLJW	\$ 997	-\$741
36"	66"	TS7Q6TCLJ	\$366	-\$177	TS7Q6TCLJW	\$1026	-\$746
42"	48"	TS748TCLJ	\$331	-\$177	TS748TCLJW	\$ 985	-\$741
42"	54"	TS745TCLJ	\$331	-\$177	TS745TCLJW	\$ 985	-\$741
42"	66"	TS746TCLJ	\$341	-\$177	TS746TCLJW	\$ 997	-\$741
42"	78"	TS747TCLJ	\$460	-\$180	TS747TCLJW	\$1109	-\$746
48"	54"	TS785TCLJ	\$341	-\$177	TS785TCLJW	\$ 997	-\$741
48"	66"	TS786TCLJ	\$341	-\$177	TS786TCLJW	\$ 997	-\$741
48"	78"	TS787TCLJ	\$455	-\$180	TS787TCLJW	\$1109	-\$746
54"	66"	TS756TCLJ	\$341	-\$177	TS756TCLJW	\$ 997	-\$741
54"	78"	TS757TCLJ	\$455	-\$177	TS757TCLJW	\$1109	-\$741
66"	78"	TS767TCLJ	\$455	-\$177	TS767TCLJW	\$1109	-\$741



For Canadian Pricing

Multiply U.S. Price by the Canadian price factor.

▶ See page 1 for details.

T Change-of-Height Junctions—Thin Trim

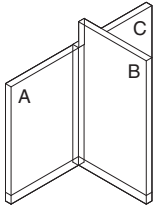

- Tip: Junction includes:**
- T change-of-height junction
 - Inside corner light seal(s)
 - T vertical trim
 - End-of-run change-of-height trim
 - Change-of-height junction cap
 - Aligners

Tip: Omit trim option omits all vertical and change-of-height trim. This option is used when stacking on base junctions. Vertical and change-of-height trim should be specified separately to span the full height of the base junction plus the stacking junction.

Tip: Remember to specify necessary junction cap and aligners if the omit trim option is selected.

Standard Includes		Required to Specify
▶ Need help? Product details, page 24	<ul style="list-style-type: none"> • Junction • Inside corner light seals • Change-of-height trim and junction cap: paint price group 1 or wood group 1 • Aligners 	1 Style number 2 Paint or wood color number for trim 3 Options, if selected (see below) ▶ See <i>Surface Materials</i> , page 668.

Surface Materials	Options	U.S. Price	Required to Specify
	Trim		
	<ul style="list-style-type: none"> • Paint price group 1 • Paint price group 2 • Paint price group 3 	No cost +\$16 +\$34	Specify paint color number. Specify paint color number. Specify paint color number.
	<ul style="list-style-type: none"> • Customiz stain on wood • Omit trim 	No cost Prices below and at right	Specify with <i>Customiz stain</i> . Specify with <i>omit trim</i> .

Specification Information						
Corresponding Panel Height	Style Number	U.S. Base Price	Option (Add \$ to Base Price)	Style Number	U.S. Base Price	Option (Add \$ to Base Price)
A B C						
			Omit Trim			Omit Trim

			Painted Trim			Wood Trim		
30"	36"	30"	TS73Q3TCTJ	\$399	-\$177	TS73Q3TCTJW	\$1090	-\$741
30"	42"	30"	TS7343TCTJ	\$399	-\$177	TS7343TCTJW	\$1090	-\$741
30"	48"	30"	TS7383TCTJ	\$399	-\$177	TS7383TCTJW	\$1090	-\$741
30"	54"	30"	TS7353TCTJ	\$431	-\$177	TS7353TCTJW	\$1103	-\$741
30"	66"	30"	TS7363TCTJ	\$476	-\$180	TS7363TCTJW	\$1115	-\$746
36"	42"	36"	TS7Q4QTCTJ	\$399	-\$177	TS7Q4QTCTJW	\$1090	-\$741
36"	48"	36"	TS7Q8QTCTJ	\$399	-\$177	TS7Q8QTCTJW	\$1090	-\$741
36"	54"	36"	TS7Q5QTCTJ	\$431	-\$177	TS7Q5QTCTJW	\$1103	-\$741
36"	66"	36"	TS7Q6QTCTJ	\$476	-\$180	TS7Q6QTCTJW	\$1115	-\$746
42"	48"	42"	TS7484TCTJ	\$431	-\$177	TS7484TCTJW	\$1103	-\$741
42"	54"	42"	TS7454TCTJ	\$431	-\$177	TS7454TCTJW	\$1103	-\$741
42"	66"	42"	TS7464TCTJ	\$476	-\$177	TS7464TCTJW	\$1115	-\$741
42"	78"	42"	TS7474TCTJ	\$570	-\$180	TS7474TCTJW	\$1203	-\$746
48"	54"	48"	TS7858TCTJ	\$476	-\$177	TS7858TCTJW	\$1115	-\$741
48"	66"	48"	TS7868TCTJ	\$476	-\$177	TS7868TCTJW	\$1115	-\$741
48"	78"	48"	TS7878TCTJ	\$570	-\$180	TS7878TCTJW	\$1203	-\$746
54"	66"	54"	TS7565TCTJ	\$476	-\$177	TS7565TCTJW	\$1115	-\$741
54"	78"	54"	TS7575TCTJ	\$570	-\$177	TS7575TCTJW	\$1203	-\$741
66"	78"	66"	TS7676TCTJ	\$570	-\$177	TS7676TCTJW	\$1203	-\$741

▶ **Specification Information, continued on next page**



For Canadian Pricing
 Multiply U.S. Price by the Canadian price factor.
 ▶ See page 1 for details.

► Specification Information, continued from previous page

Specification Information								
Corresponding Panel Height			Style Number	U.S. Base Price	Option (Add \$ to Base Price)	Style Number	U.S. Base Price	Option (Add \$ to Base Price)
A	B	C			Omit Trim			Omit Trim

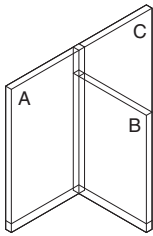

- Tip: Junction includes:
- T change-of-height junction
 - Inside corner light seals
 - T vertical trim
 - T change-of-height trim
 - 90° junction cap
 - Aligners

Painted Trim					Wood Trim			
36"	30"	36"	TS7Q3QTCTJ	\$399	-\$177	TS7Q3QTCTJW	\$1090	-\$741
42"	30"	42"	TS7434TCTJ	\$399	-\$177	TS7434TCTJW	\$1090	-\$741
48"	30"	48"	TS7838TCTJ	\$399	-\$177	TS7838TCTJW	\$1090	-\$741
48"	42"	48"	TS7848TCTJ	\$431	-\$177	TS7848TCTJW	\$1103	-\$741
54"	30"	54"	TS7535TCTJ	\$431	-\$177	TS7535TCTJW	\$1103	-\$741
66"	30"	66"	TS7636TCTJ	\$476	-\$180	TS7636TCTJW	\$1115	-\$746
42"	36"	42"	TS74Q4TCTJ	\$399	-\$177	TS74Q4TCTJW	\$1090	-\$741
48"	36"	48"	TS78Q8TCTJ	\$399	-\$177	TS78Q8TCTJW	\$1090	-\$741
54"	36"	54"	TS75Q5TCTJ	\$431	-\$177	TS75Q5TCTJW	\$1103	-\$741
66"	36"	66"	TS76Q6TCTJ	\$476	-\$180	TS76Q6TCTJW	\$1115	-\$746
54"	42"	54"	TS7545TCTJ	\$431	-\$177	TS7545TCTJW	\$1103	-\$741
54"	48"	54"	TS7585TCTJ	\$476	-\$177	TS7585TCTJW	\$1115	-\$741
66"	42"	66"	TS7646TCTJ	\$476	-\$177	TS7646TCTJW	\$1115	-\$741
78"	42"	78"	TS7747TCTJ	\$570	-\$180	TS7747TCTJW	\$1203	-\$746
66"	48"	66"	TS7686TCTJ	\$476	-\$177	TS7686TCTJW	\$1115	-\$741
78"	48"	78"	TS7787TCTJ	\$570	-\$180	TS7787TCTJW	\$1203	-\$746
66"	54"	66"	TS7656TCTJ	\$476	-\$177	TS7656TCTJW	\$1115	-\$741
78"	54"	78"	TS7757TCTJ	\$570	-\$177	TS7757TCTJW	\$1203	-\$741
78"	66"	78"	TS7767TCTJ	\$570	-\$177	TS7767TCTJW	\$1203	-\$741

► Specification Information, continued on next page



For Canadian Pricing
Multiply U.S. Price by the Canadian price factor.
► See page 1 for details.

T Change-of-Height Junctions—Thin Trim, continued

► Specification Information, continued from previous page

Specification Information								
Corresponding Panel Height			Style Number	U.S. Base Price	Option (Add \$ to Base Price)	Style Number	U.S. Base Price	Option (Add \$ to Base Price)
A	B	C						

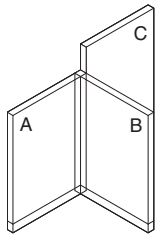

- Tip: Junction includes:
- T change-of-height junction
 - Inside corner light seals
 - T vertical trim
 - End-of-run change-of-height trim
 - Change-of-height junction cap
 - Aligners

Tip: When A and C are different heights, the junction is shipped right-handed. For a left-handed junction a post will need to be moved during installation.

			Painted Trim			Wood Trim		
30"	30"	36"	TS733QTCTJ	\$399	-\$177	TS733QTCTJW	\$1090	-\$741
30"	30"	42"	TS7334TCTJ	\$399	-\$177	TS7334TCTJW	\$1090	-\$741
30"	30"	48"	TS7338TCTJ	\$399	-\$177	TS7338TCTJW	\$1090	-\$741
30"	30"	54"	TS7335TCTJ	\$431	-\$177	TS7335TCTJW	\$1103	-\$741
30"	30"	66"	TS7336TCTJ	\$476	-\$180	TS7336TCTJW	\$1115	-\$746
36"	36"	42"	TS7QQ4TCTJ	\$399	-\$177	TS7QQ4TCTJW	\$1090	-\$741
36"	36"	48"	TS7QQ8TCTJ	\$399	-\$177	TS7QQ8TCTJW	\$1090	-\$741
36"	36"	54"	TS7QQ5TCTJ	\$431	-\$177	TS7QQ5TCTJW	\$1103	-\$741
36"	36"	66"	TS7QQ6TCTJ	\$476	-\$180	TS7QQ6TCTJW	\$1115	-\$746
42"	42"	48"	TS7448TCTJ	\$431	-\$177	TS7448TCTJW	\$1103	-\$741
42"	42"	54"	TS7445TCTJ	\$431	-\$177	TS7445TCTJW	\$1103	-\$741
42"	42"	66"	TS7446TCTJ	\$476	-\$177	TS7446TCTJW	\$1115	-\$741
42"	42"	78"	TS7447TCTJ	\$570	-\$180	TS7447TCTJW	\$1203	-\$746
48"	48"	54"	TS7885TCTJ	\$476	-\$177	TS7885TCTJW	\$1115	-\$741
48"	48"	66"	TS7886TCTJ	\$476	-\$177	TS7886TCTJW	\$1115	-\$741
48"	48"	78"	TS7887TCTJ	\$570	-\$180	TS7887TCTJW	\$1203	-\$746
54"	54"	66"	TS7556TCTJ	\$476	-\$177	TS7556TCTJW	\$1115	-\$741
54"	54"	78"	TS7557TCTJ	\$570	-\$177	TS7557TCTJW	\$1203	-\$741
66"	66"	78"	TS7667TCTJ	\$570	-\$177	TS7667TCTJW	\$1203	-\$741

► Specification Information, continued on next page



For Canadian Pricing
 Multiply U.S. Price by the Canadian price factor.
 ► See page 1 for details.

► Specification Information, continued from previous page

Specification Information								
Corresponding Panel Height			Style Number	U.S. Base Price	Option (Add \$ to Base Price)	Style Number	U.S. Base Price	Option (Add \$ to Base Price)
A	B	C			Omit Trim			Omit Trim

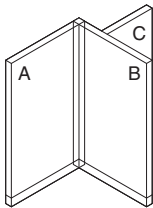

Tip: Junction includes:

- T change-of-height junction
- Inside corner light seals
- T vertical trim
- L change-of-height trim
- 90° junction cap
- Aligners

Tip: When A and C are different heights, the junction is shipped right-handed. For a left-handed junction a post will need to be moved during installation.

			Painted Trim			Wood Trim		
36"	36"	30"	TS7QQ3TCTJ	\$399	-\$177	TS7QQ3TCTJW	\$1090	-\$741
42"	42"	30"	TS7443TCTJ	\$399	-\$177	TS7443TCTJW	\$1090	-\$741
42"	42"	36"	TS744QTCTJ	\$399	-\$177	TS744QTCTJW	\$1090	-\$741
48"	48"	36"	TS788QTCTJ	\$399	-\$177	TS788QTCTJW	\$1090	-\$741
54"	54"	36"	TS755QTCTJ	\$431	-\$177	TS755QTCTJW	\$1103	-\$741
66"	66"	36"	TS766QTCTJ	\$476	-\$180	TS766QTCTJW	\$1115	-\$746
48"	48"	30"	TS7883TCTJ	\$399	-\$177	TS7883TCTJW	\$1090	-\$741
48"	48"	42"	TS7884TCTJ	\$431	-\$177	TS7884TCTJW	\$1103	-\$741
54"	54"	30"	TS7553TCTJ	\$431	-\$177	TS7553TCTJW	\$1103	-\$741
66"	66"	30"	TS7663TCTJ	\$476	-\$180	TS7663TCTJW	\$1115	-\$746
54"	54"	42"	TS7554TCTJ	\$431	-\$177	TS7554TCTJW	\$1103	-\$741
54"	54"	48"	TS7558TCTJ	\$476	-\$177	TS7558TCTJW	\$1115	-\$741
66"	66"	42"	TS7664TCTJ	\$476	-\$177	TS7664TCTJW	\$1115	-\$741
78"	78"	42"	TS7774TCTJ	\$570	-\$180	TS7774TCTJW	\$1203	-\$746
66"	66"	48"	TS7668TCTJ	\$476	-\$177	TS7668TCTJW	\$1115	-\$741
78"	78"	48"	TS7778TCTJ	\$570	-\$180	TS7778TCTJW	\$1203	-\$746
66"	66"	54"	TS7665TCTJ	\$476	-\$177	TS7665TCTJW	\$1115	-\$741
78"	78"	54"	TS7775TCTJ	\$570	-\$177	TS7775TCTJW	\$1203	-\$741
78"	78"	66"	TS7776TCTJ	\$570	-\$177	TS7776TCTJW	\$1203	-\$741

 **For Canadian Pricing**
Multiply U.S. Price by the Canadian price factor.
► See page 1 for details.

X Change-of-Height Junctions—Thin Trim

Standard Includes		Required to Specify
<ul style="list-style-type: none"> ▶ Need help? Product details, page 24 	<ul style="list-style-type: none"> • Junction • Inside corner light seals • Trim/junction cap: paint price group 1 or wood group 1 • Aligners 	<ol style="list-style-type: none"> 1 Style number 2 Paint or wood color number for junction cap 3 Options, if selected (see below) <ul style="list-style-type: none"> ▶ See <i>Surface Materials</i>, page 668.

Options	U.S. Price	Required to Specify
Surface Materials Trim <ul style="list-style-type: none"> • Paint price group 1 • Paint price group 2 • Paint price group 3 	No cost +\$16 +\$34	Specify paint color number. Specify paint color number. Specify paint color number.
<ul style="list-style-type: none"> • Customiz stain on wood • Omit trim 	No cost Prices below and at right	Specify with <i>Customiz stain</i> . Specify with <i>omit trim</i> .

Tip: Omit trim option omits all change-of-height trim. This option is used when stacking on base junctions. Change-of-height trim should be specified separately to span the full height of the base junction plus stacking junction.

Tip: Remember to specify necessary junction cap and aligners if the omit trim option is selected.

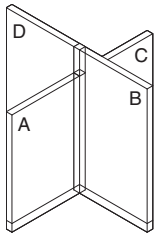

Tip: Junction includes:

- X change-of-height junction
- Two T change-of-height trims
- 90° junction cap
- Aligners

Specification Information									
Corresponding Panel Height				Style Number	U.S. Base Price	Option (Add \$ to Base Price)	Style Number	U.S. Base Price	Option (Add \$ to Base Price)
A	B	C	D						
						Omit Trim			Omit Trim

				Painted Trim			Wood Trim		
30"	36"	30"	36"	TS73Q3QTCXJ	\$420	-\$172	TS73Q3QTCXJW	\$ 996	-\$670
30"	42"	30"	42"	TS73434TCXJ	\$420	-\$172	TS73434TCXJW	\$ 996	-\$670
30"	48"	30"	48"	TS73838TCXJ	\$420	-\$172	TS73838TCXJW	\$ 996	-\$670
30"	54"	30"	54"	TS73535TCXJ	\$448	-\$172	TS73535TCXJW	\$1027	-\$670
30"	66"	30"	66"	TS73636TCXJ	\$492	-\$180	TS73636TCXJW	\$1074	-\$678
36"	42"	36"	42"	TS7Q4Q4TCXJ	\$420	-\$172	TS7Q4Q4TCXJW	\$ 996	-\$670
36"	48"	36"	48"	TS7Q8Q8TCXJ	\$420	-\$172	TS7Q8Q8TCXJW	\$ 996	-\$670
36"	54"	36"	54"	TS7Q5Q5TCXJ	\$448	-\$172	TS7Q5Q5TCXJW	\$1027	-\$670
36"	66"	36"	66"	TS7Q6Q6TCXJ	\$492	-\$180	TS7Q6Q6TCXJW	\$1074	-\$678
42"	48"	42"	48"	TS74848TCXJ	\$448	-\$172	TS74848TCXJW	\$1027	-\$670
42"	54"	42"	54"	TS74545TCXJ	\$448	-\$172	TS74545TCXJW	\$1027	-\$670
42"	66"	42"	66"	TS74646TCXJ	\$492	-\$172	TS74646TCXJW	\$1074	-\$670
42"	78"	42"	78"	TS74747TCXJ	\$570	-\$180	TS74747TCXJW	\$1147	-\$678
48"	54"	48"	54"	TS78585TCXJ	\$492	-\$172	TS78585TCXJW	\$1074	-\$670
48"	66"	48"	66"	TS78686TCXJ	\$492	-\$172	TS78686TCXJW	\$1074	-\$670
48"	78"	48"	78"	TS78787TCXJ	\$570	-\$180	TS78787TCXJW	\$1147	-\$678
54"	66"	54"	66"	TS75656TCXJ	\$492	-\$172	TS75656TCXJW	\$1074	-\$670
54"	78"	54"	78"	TS75757TCXJ	\$570	-\$172	TS75757TCXJW	\$1147	-\$670
66"	78"	66"	78"	TS76767TCXJ	\$570	-\$172	TS76767TCXJW	\$1147	-\$670

▶ Specification Information, continued on next page

 **For Canadian Pricing**
 Multiply U.S. Price by the Canadian price factor.
 ▶ See page 1 for details.

► Specification Information, continued from previous page

Specification Information									
Corresponding Panel Height				Style Number	U.S. Base Price	Option (Add \$ to Base Price)	Style Number	U.S. Base Price	Option (Add \$ to Base Price)
A	B	C	D			Omit Trim			Omit Trim

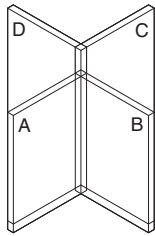

- Tip: Junction includes:
- X change-of-height junction
 - Inside corner light seals
 - L change-of-height trim
 - 90° junction cap
 - Aligners

Painted Trim						Wood Trim			
30"	30"	36"	36"	TS733QQTCXJ	\$420	-\$94	TS733QQTCXJW	\$761	-\$388
30"	30"	42"	42"	TS73344TCXJ	\$420	-\$94	TS73344TCXJW	\$761	-\$388
30"	30"	48"	48"	TS73388TCXJ	\$420	-\$94	TS73388TCXJW	\$761	-\$388
30"	30"	54"	54"	TS73355TCXJ	\$448	-\$94	TS73355TCXJW	\$789	-\$388
30"	30"	66"	66"	TS73366TCXJ	\$492	-\$98	TS73366TCXJW	\$832	-\$392
36"	36"	42"	42"	TS7QQ44TCXJ	\$420	-\$94	TS7QQ44TCXJW	\$761	-\$388
36"	36"	48"	48"	TS7QQ88TCXJ	\$420	-\$94	TS7QQ88TCXJW	\$761	-\$388
36"	36"	54"	54"	TS7QQ55TCXJ	\$448	-\$94	TS7QQ55TCXJW	\$789	-\$388
36"	36"	66"	66"	TS7QQ66TCXJ	\$492	-\$98	TS7QQ66TCXJW	\$832	-\$392
42"	42"	48"	48"	TS74488TCXJ	\$448	-\$94	TS74488TCXJW	\$789	-\$388
42"	42"	54"	54"	TS74455TCXJ	\$448	-\$94	TS74455TCXJW	\$789	-\$388
42"	42"	66"	66"	TS74466TCXJ	\$492	-\$94	TS74466TCXJW	\$832	-\$388
42"	42"	78"	78"	TS74477TCXJ	\$570	-\$98	TS74477TCXJW	\$909	-\$392
48"	48"	54"	54"	TS78855TCXJ	\$492	-\$94	TS78855TCXJW	\$832	-\$388
48"	48"	66"	66"	TS78866TCXJ	\$492	-\$94	TS78866TCXJW	\$832	-\$388
48"	48"	78"	78"	TS78877TCXJ	\$570	-\$98	TS78877TCXJW	\$909	-\$392
54"	54"	66"	66"	TS75566TCXJ	\$492	-\$94	TS75566TCXJW	\$832	-\$388
54"	54"	78"	78"	TS75577TCXJ	\$570	-\$94	TS75577TCXJW	\$909	-\$388
66"	66"	78"	78"	TS76677TCXJ	\$570	-\$94	TS76677TCXJW	\$909	-\$388

► Specification Information, continued on next page

 **For Canadian Pricing**
Multiply U.S. Price by the Canadian price factor.
► See page 1 for details.

X Change-of-Height Junctions—Thin Trim, continued

► Specification Information, continued from previous page

Specification Information									
Corresponding Panel Height				Style Number	U.S. Base Price	Option (Add \$ to Base Price)	Style Number	U.S. Base Price	Option (Add \$ to Base Price)
A	B	C	D			Omit Trim			Omit Trim

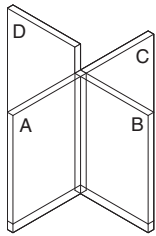

- Tip: Junction includes:
- X change-of-height junction
 - Inside corner light seals
 - End-of-run change-of-height trim
 - Change-of-height junction cap
 - Aligners

Painted Trim					Wood Trim				
30"	30"	30"	36"	TS7333QTCXJ	\$420	-\$94	TS7333QTCXJW	\$761	-\$388
30"	30"	30"	42"	TS73334TCXJ	\$420	-\$94	TS73334TCXJW	\$761	-\$388
30"	30"	30"	48"	TS73338TCXJ	\$420	-\$94	TS73338TCXJW	\$761	-\$388
30"	30"	30"	54"	TS73335TCXJ	\$448	-\$94	TS73335TCXJW	\$789	-\$388
30"	30"	30"	66"	TS73336TCXJ	\$492	-\$98	TS73336TCXJW	\$832	-\$392
36"	36"	36"	42"	TS7QQQ4TCXJ	\$420	-\$94	TS7QQQ4TCXJW	\$761	-\$388
36"	36"	36"	48"	TS7QQQ8TCXJ	\$420	-\$94	TS7QQQ8TCXJW	\$761	-\$388
36"	36"	36"	54"	TS7QQQ5TCXJ	\$448	-\$94	TS7QQQ5TCXJW	\$789	-\$388
36"	36"	36"	66"	TS7QQQ6TCXJ	\$492	-\$98	TS7QQQ6TCXJW	\$832	-\$392
42"	42"	42"	48"	TS74448TCXJ	\$448	-\$94	TS74448TCXJW	\$789	-\$388
42"	42"	42"	54"	TS74445TCXJ	\$448	-\$94	TS74445TCXJW	\$789	-\$388
42"	42"	42"	66"	TS74446TCXJ	\$492	-\$94	TS74446TCXJW	\$832	-\$388
42"	42"	42"	78"	TS74447TCXJ	\$570	-\$98	TS74447TCXJW	\$909	-\$392
48"	48"	48"	54"	TS78885TCXJ	\$492	-\$94	TS78885TCXJW	\$832	-\$388
48"	48"	48"	66"	TS78886TCXJ	\$492	-\$94	TS78886TCXJW	\$832	-\$388
48"	48"	48"	78"	TS78887TCXJ	\$570	-\$98	TS78887TCXJW	\$909	-\$392
54"	54"	54"	66"	TS75556TCXJ	\$492	-\$94	TS75556TCXJW	\$832	-\$388
54"	54"	54"	78"	TS75557TCXJ	\$570	-\$94	TS75557TCXJW	\$909	-\$388
66"	66"	66"	78"	TS76667TCXJ	\$570	-\$94	TS76667TCXJW	\$909	-\$388

► Specification Information, continued on next page



For Canadian Pricing
 Multiply U.S. Price by the Canadian price factor.
 ► See page 1 for details.

► Specification Information, continued from previous page

Specification Information									
Corresponding Panel Height				Style Number	U.S. Base Price	Option (Add \$ to Base Price)	Style Number	U.S. Base Price	Option (Add \$ to Base Price)
A	B	C	D			Omit Trim			Omit Trim

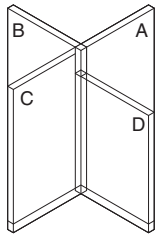

- Tip: Junction includes:
- X change-of-height junction
 - Inside corner light seals
 - T change-of-height trim
 - 90° junction cap
 - Aligners

				Painted Trim			Wood Trim		
36"	36"	36"	30"	TS7QQQ3TCXJ	\$420	-\$94	TS7QQQ3TCXJW	\$761	-\$388
42"	42"	42"	30"	TS74443TCXJ	\$420	-\$94	TS74443TCXJW	\$761	-\$388
42"	42"	42"	36"	TS7444QTCXJ	\$420	-\$94	TS7444QTCXJW	\$761	-\$388
48"	48"	48"	36"	TS7888QTCXJ	\$420	-\$94	TS7888QTCXJW	\$761	-\$388
54"	54"	54"	36"	TS7555QTCXJ	\$448	-\$94	TS7555QTCXJW	\$789	-\$388
66"	66"	66"	36"	TS7666QTCXJ	\$492	-\$98	TS7666QTCXJW	\$832	-\$392
48"	48"	48"	30"	TS78883TCXJ	\$420	-\$94	TS78883TCXJW	\$761	-\$388
48"	48"	48"	42"	TS78884TCXJ	\$448	-\$94	TS78884TCXJW	\$789	-\$388
54"	54"	54"	30"	TS75553TCXJ	\$448	-\$94	TS75553TCXJW	\$789	-\$388
54"	54"	54"	42"	TS75554TCXJ	\$448	-\$94	TS75554TCXJW	\$789	-\$388
54"	54"	54"	48"	TS75558TCXJ	\$492	-\$94	TS75558TCXJW	\$832	-\$388
66"	66"	66"	30"	TS76663TCXJ	\$492	-\$98	TS76663TCXJW	\$832	-\$392
66"	66"	66"	42"	TS76664TCXJ	\$492	-\$94	TS76664TCXJW	\$832	-\$388
66"	66"	66"	48"	TS76668TCXJ	\$492	-\$94	TS76668TCXJW	\$832	-\$388
66"	66"	66"	54"	TS76665TCXJ	\$492	-\$94	TS76665TCXJW	\$832	-\$388
78"	78"	78"	42"	TS77774TCXJ	\$570	-\$98	TS77774TCXJW	\$909	-\$392
78"	78"	78"	48"	TS77778TCXJ	\$570	-\$98	TS77778TCXJW	\$909	-\$392
78"	78"	78"	54"	TS77775TCXJ	\$570	-\$94	TS77775TCXJW	\$909	-\$388
78"	78"	78"	66"	TS77776TCXJ	\$570	-\$94	TS77776TCXJW	\$909	-\$388

 **For Canadian Pricing**
Multiply U.S. Price by the Canadian price factor.
► See page 1 for details.

V Change-of-Height Junctions—Thin Trim

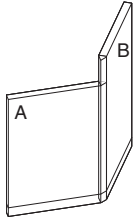

- Tip: Junction includes:**
- V change-of-height junction
 - V vertical trim
 - 120° change-of-height trim
 - 120° junction cap
 - Aligner

Tip: Omit trim option omits all vertical and change-of-height trim. This option is used when stacking on base junctions. Vertical and change-of-height trim should be specified separately to span the full height of the base junction plus stacking junction.

Tip: Remember to specify necessary junction caps and aligners if the omit trim option is selected.

Tip: Change-of-height junction ships right-handed. For a left-handed junction, a post will need to be moved during installation.

Standard Includes	Required to Specify
<ul style="list-style-type: none"> ▶ Need help? Product details, page 24 • Junction • Change-of-height trim and junction cap: paint price group 1 or wood group 1 • Aligners 	<ul style="list-style-type: none"> 1 Style number 2 Paint or wood color number for trim 3 Options, if selected (see below) ▶ See <i>Surface Materials</i>, page 668.

Surface Materials	Options	U.S. Price	Required to Specify
	Trim		
	<ul style="list-style-type: none"> • Paint price group 1 • Paint price group 2 • Paint price group 3 	<ul style="list-style-type: none"> No cost +\$16 +\$34 	<ul style="list-style-type: none"> Specify paint color number. Specify paint color number. Specify paint color number.
	<ul style="list-style-type: none"> • Customiz stain on wood • Omit trim 	<ul style="list-style-type: none"> No cost Prices below 	<ul style="list-style-type: none"> Specify with <i>Customiz stain</i>. Specify with <i>omit trim</i>.

Specification Information						
Corresponding Panel Height	Style Number	U.S. Base Price	Option (Add \$ to Base Price)	Style Number	U.S. Base Price	Option (Add \$ to Base Price)
A	B		Omit Trim			Omit Trim

Painted Trim				Wood Trim			
30"	36"	TS73QTCVJ	\$352	-\$196	TS73QTCVJW	\$1014	-\$783
30"	42"	TS734TCVJ	\$352	-\$196	TS734TCVJW	\$1014	-\$783
30"	48"	TS738TCVJ	\$352	-\$196	TS738TCVJW	\$1014	-\$783
30"	54"	TS735TCVJ	\$366	-\$196	TS735TCVJW	\$1026	-\$783
30"	66"	TS736TCVJ	\$392	-\$201	TS736TCVJW	\$1097	-\$789
36"	42"	TS7Q4TCVJ	\$352	-\$196	TS7Q4TCVJW	\$1014	-\$783
36"	48"	TS7Q8TCVJ	\$352	-\$196	TS7Q8TCVJW	\$1014	-\$783
36"	54"	TS7Q5TCVJ	\$366	-\$196	TS7Q5TCVJW	\$1026	-\$783
36"	66"	TS7Q6TCVJ	\$392	-\$201	TS7Q6TCVJW	\$1097	-\$789
42"	48"	TS748TCVJ	\$352	-\$196	TS748TCVJW	\$1014	-\$783
42"	54"	TS745TCVJ	\$352	-\$196	TS745TCVJW	\$1014	-\$783
42"	66"	TS746TCVJ	\$366	-\$196	TS746TCVJW	\$1026	-\$783
42"	78"	TS747TCVJ	\$477	-\$201	TS747TCVJW	\$1133	-\$789
48"	54"	TS785TCVJ	\$366	-\$196	TS785TCVJW	\$1026	-\$783
48"	66"	TS786TCVJ	\$366	-\$196	TS786TCVJW	\$1026	-\$783
48"	78"	TS787TCVJ	\$477	-\$201	TS787TCVJW	\$1133	-\$789
54"	66"	TS756TCVJ	\$366	-\$196	TS756TCVJW	\$1026	-\$783
54"	78"	TS757TCVJ	\$477	-\$196	TS757TCVJW	\$1133	-\$783
66"	78"	TS767TCVJ	\$477	-\$196	TS767TCVJW	\$1133	-\$783



For Canadian Pricing
 Multiply U.S. Price by the Canadian price factor.
 ▶ See page 1 for details.

Y Change-of-Height Junctions—Thin Trim

Standard Includes		Required to Specify
▶ Need help? Product details, page 24	<ul style="list-style-type: none"> • Junction • Change-of-height trim and junction cap: paint price group 1 or wood group 1 • Aligners 	1 Style number 2 Paint or wood color number for trim 3 Options, if selected (see below) ▶ See <i>Surface Materials</i> , page 668.

Options	U.S. Price	Required to Specify
Surface Materials Trim <ul style="list-style-type: none"> • Paint price group 1 • Paint price group 2 • Paint price group 3 	No cost +\$16 +\$34	Specify paint color number. Specify paint color number. Specify paint color number.
<ul style="list-style-type: none"> • Customiz stain on wood • Omit trim 	No cost Prices below	Specify <i>with Customiz stain</i> . Specify <i>with omit trim</i> .

Tip: Omit trim option omits all change-of-height trim. This option is used when stacking on base junctions. Change-of-height trim should be specified separately to span the full height of the base junction plus stacking junction.

Tip: Remember to specify necessary junction caps and aligners if the omit trim option is selected.

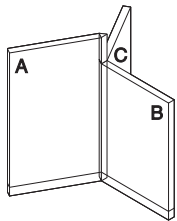

Tip: Junction includes:

- Y change-of-height junction
- 120° change-of-height trim
- 120° junction cap

Specification Information						
Corresponding Panel Height	Style Number	U.S. Base Price	Option (Add \$ to Base Price)	Style Number	U.S. Base Price	Option (Add \$ to Base Price)
A B C			Omit Trim			Omit Trim

			Painted Trim			Wood Trim		
36"	30"	30"	TS7Q33TCYJ	\$446	-\$94	TS7Q33TCYJW	\$787	-\$388
42"	30"	30"	TS7433TCYJ	\$446	-\$94	TS7433TCYJW	\$787	-\$388
42"	36"	36"	TS74QQTCYJ	\$446	-\$94	TS74QQTCYJW	\$787	-\$388
48"	36"	36"	TS78QQTCYJ	\$446	-\$94	TS78QQTCYJW	\$787	-\$388
54"	36"	36"	TS75QQTCYJ	\$473	-\$94	TS75QQTCYJW	\$813	-\$388
66"	36"	36"	TS76QQTCYJ	\$518	-\$98	TS76QQTCYJW	\$859	-\$392
48"	30"	30"	TS7833TCYJ	\$446	-\$94	TS7833TCYJW	\$787	-\$388
48"	42"	42"	TS7844TCYJ	\$473	-\$94	TS7844TCYJW	\$813	-\$388
54"	30"	30"	TS7533TCYJ	\$473	-\$94	TS7533TCYJW	\$813	-\$388
54"	48"	48"	TS7588TCYJ	\$518	-\$94	TS7588TCYJW	\$859	-\$388
66"	30"	30"	TS7633TCYJ	\$518	-\$98	TS7633TCYJW	\$859	-\$392
54"	42"	42"	TS7544TCYJ	\$473	-\$94	TS7544TCYJW	\$813	-\$388
66"	42"	42"	TS7644TCYJ	\$518	-\$94	TS7644TCYJW	\$859	-\$388
78"	42"	42"	TS7744TCYJ	\$554	-\$98	TS7744TCYJW	\$892	-\$388
66"	48"	48"	TS7688TCYJ	\$518	-\$94	TS7688TCYJW	\$859	-\$388
78"	48"	48"	TS7788TCYJ	\$595	-\$98	TS7788TCYJW	\$935	-\$392
66"	54"	54"	TS7655TCYJ	\$518	-\$94	TS7655TCYJW	\$859	-\$388
78"	54"	54"	TS7755TCYJ	\$595	-\$94	TS7755TCYJW	\$935	-\$388
78"	66"	66"	TS7766TCYJ	\$595	-\$94	TS7766TCYJW	\$935	-\$388

▶ **Specification Information, continued on next page**

 **For Canadian Pricing**
 Multiply U.S. Price by the Canadian price factor.
 ▶ See page 1 for details.

► Specification Information, continued from previous page

Specification Information										
Corresponding Panel Height			Style Number	U.S. Base Price	Option (Add \$ to Base Price)	Style Number	U.S. Base Price	Option (Add \$ to Base Price)		
A	B	C			Omit Trim			Omit Trim		
Painted Trim					Wood Trim					
30"	36"	36"	TS73QQTCYJ	\$446	-\$94	TS73QQTCYJW	\$787	-\$388		
30"	42"	42"	TS7344TCYJ	\$446	-\$94	TS7344TCYJW	\$787	-\$388		
30"	48"	48"	TS7388TCYJ	\$446	-\$94	TS7388TCYJW	\$787	-\$388		
30"	54"	54"	TS7355TCYJ	\$473	-\$94	TS7355TCYJW	\$813	-\$388		
30"	66"	66"	TS7366TCYJ	\$518	-\$98	TS7366TCYJW	\$859	-\$392		
36"	42"	42"	TS7Q44TCYJ	\$446	-\$94	TS7Q44TCYJW	\$787	-\$388		
36"	48"	48"	TS7Q88TCYJ	\$446	-\$94	TS7Q88TCYJW	\$787	-\$388		
36"	54"	54"	TS7Q55TCYJ	\$473	-\$94	TS7Q55TCYJW	\$813	-\$388		
36"	66"	66"	TS7Q66TCYJ	\$518	-\$98	TS7Q66TCYJW	\$859	-\$392		
42"	48"	48"	TS7488TCYJ	\$473	-\$94	TS7488TCYJW	\$813	-\$388		
42"	54"	54"	TS7455TCYJ	\$473	-\$94	TS7455TCYJW	\$813	-\$388		
42"	66"	66"	TS7466TCYJ	\$518	-\$94	TS7466TCYJW	\$859	-\$388		
42"	78"	78"	TS7477TCYJ	\$554	-\$98	TS7477TCYJW	\$892	-\$388		
48"	54"	54"	TS7855TCYJ	\$518	-\$94	TS7855TCYJW	\$859	-\$388		
48"	66"	66"	TS7866TCYJ	\$518	-\$94	TS7866TCYJW	\$859	-\$388		
48"	78"	78"	TS7877TCYJ	\$595	-\$98	TS7877TCYJW	\$935	-\$392		
54"	66"	66"	TS7566TCYJ	\$518	-\$94	TS7566TCYJW	\$859	-\$388		
54"	78"	78"	TS7577TCYJ	\$595	-\$94	TS7577TCYJW	\$935	-\$388		
66"	78"	78"	TS7677TCYJ	\$595	-\$94	TS7677TCYJW	\$935	-\$388		

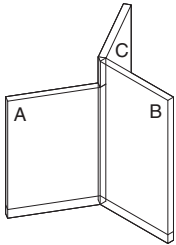

Tip: Junction includes:

- Y change-of-height junction
- V change-of-height trim
- 120° junction cap
- Aligner



For Canadian Pricing
Multiply U.S. Price by the Canadian price factor.
► See page 1 for details.

Wall-Start Junctions



Tip: When using in an off-module application, off-module panel connector must be ordered separately.
 ▶ Page 98

Standard Includes	Required to Specify
▶ Need help? Product details, page 30	• Junction Style number

Specification Information		
Height	Style Number	U.S. Price
30"	TS730WPJ	\$323
36"	TS736WPJ	\$323
42"	TS742WPJ	\$323
48"	TS748WPJ	\$323
54"	TS754WPJ	\$323
66"	TS766WPJ	\$323
78"	TS778WPJ	\$449



For Canadian Pricing
 Multiply U.S. Price by the Canadian price factor.
 ▶ See page 1 for details.

Brackets

Floor Anchor Bracket

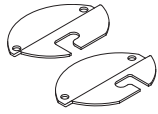

Tip: Floor anchor bolts are not included.

Standard Includes	Required to Specify
<ul style="list-style-type: none"> ▶ Need help? Product details, page 21 • Two-piece floor anchor bracket: black paint only 	Style number

Specification Information	
• Style Number	• U.S. Price
CBRKTS	\$63

Junction Stabilizer Brackets

Tip: Junction stabilizer bracket blocks power routing in the base and just above the base areas. Lay-in cable routing in the base is also blocked by the bracket.

Standard Includes	Required to Specify
<ul style="list-style-type: none"> ▶ Need help? Product details, page 21 • Bracket: black paint only 	Style number

Specification Information		
• Height	• Style Number	• U.S. Price
10½"	TS7SBNJ	\$113

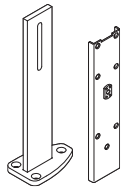

Tip: Junctions manufactured on or after October 10, 2011 will only work with TS7SBNJ junction stabilizer bracket.

10½"	TS7SB	\$113
------	--------------	-------

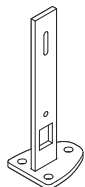

Tip: Junctions manufactured before October 10, 2011 will only work with TS7SB junction stabilizer bracket.



For Canadian Pricing
 Multiply U.S. Price by the Canadian price factor.
 ▶ See page 1 for details.

Off-Module Panel Connectors

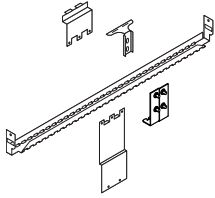

Tip: Must be used with wall-start junctions, ordered separately.

▶ Page 345

Tip: Off-module panel connector works with thin, square, and oval style trims. Top cap filler included in package is only used with oval style trims. Thin and square style trims do not require a top cap filler.

Tip: Wall-start junctions manufactured before October 2002 will not work with off-module panel connectors.

Tip: When using with wall-start junction manufactured before October 10, 2011, the bottom bracket must be replaced with part number T500938MP from Service Parts.

Standard Includes		Required to Specify
▶ Need help? Product details, page 98	<ul style="list-style-type: none"> • Top and bottom bracket • Bottom channel • Top cap filler (oval style): plastic 	<ul style="list-style-type: none"> 1 Style number 2 Plastic color number for filler <p>▶ See <i>Surface Materials</i>, page 668.</p>

Specification Information		
Width	Style Number	U.S. Price
24"	TS724BKT	\$409
30"	TS730BKT	\$409
36"	TS736BKT	\$409
42"	TS742BKT	\$409
48"	TS748BKT	\$409
60"	TS760BKT	\$409
72"	TS772BKT	\$409



For Canadian Pricing

Multiply U.S. Price by the Canadian price factor.

▶ See page 1 for details.

Stacking Junctions

Stacking In-Line Panel Junctions—Thin Trim



Tip: Stacking in-line junctions do not require junction cap and trim.

Standard Includes	Required to Specify
-------------------	---------------------

- | | |
|-----------------------------------------------------------------------------------------|-----------------------------------------------------------------------------------------|
| <ul style="list-style-type: none"> ▶ Need help? Product details, page 32 | <ul style="list-style-type: none"> • Junction • Fork connectors |
|-----------------------------------------------------------------------------------------|-----------------------------------------------------------------------------------------|

Style number

Specification Information		
Height	Style Number	U.S. Price

6"	TS76IPJS	\$178
12"	TS712IPJS	\$178
18"	TS718IPJS	\$178
24"	TS724IPJS	\$178
⋮	⋮	⋮

Stacking End-of-Run Panel Junctions—Thin Trim



Tip: Stacking end-of-run junctions do not include trim. Trim is specified separately to span entire height of base junction plus stacking junction.

Tip: 36" stacker is only used in build your own change-of-height applications. It should never be used as an end-of-run stacking junction.

Standard Includes	Required to Specify
-------------------	---------------------

- | | |
|-----------------------------------------------------------------------------------------|----------------------------------------------------------------------------------------|
| <ul style="list-style-type: none"> ▶ Need help? Product details, page 32 | <ul style="list-style-type: none"> • Junction • Fork connector |
|-----------------------------------------------------------------------------------------|----------------------------------------------------------------------------------------|

Style number

Specification Information		
Height	Style Number	U.S. Price

6"	TS76TEPJS	\$242
12"	TS712TEPJS	\$242
18"	TS718TEPJS	\$242
24"	TS724TEPJS	\$242
36"	TS736TEPJS	\$242
⋮	⋮	⋮

Stacking Wall-Start Junctions



For Canadian Pricing
 Multiply U.S. Price by the Canadian price factor.
 ▶ See page 1 for details.

Standard Includes	Required to Specify
-------------------	---------------------

- | | |
|-----------------------------------------------------------------------------------------|----------------------------------------------------------------------------------------|
| <ul style="list-style-type: none"> ▶ Need help? Product details, page 32 | <ul style="list-style-type: none"> • Junction • Fork connector |
|-----------------------------------------------------------------------------------------|----------------------------------------------------------------------------------------|

Style number

Specification Information		
Height	Style Number	U.S. Price

6"	TS76WPJS	\$486
12"	TS712WPJS	\$486
18"	TS718WPJS	\$486
24"	TS724WPJS	\$486
⋮	⋮	⋮

Stacking L, T, X, V, and Y Panel Junctions—Thin Trim

Tip: Stacking corner junctions do not include trim. Trim is specified separately to span entire height of base junction plus stacking junction.

Tip: Junction cap is not included and must be specified separately.



Standard Includes	Required to Specify
-------------------	---------------------

- | | |
|--------------------------------------------------------------------------------------------------|-----------------------------------------------------------------------------------------|
| <ul style="list-style-type: none"> ▶ Need help? Product details, page 32 | <ul style="list-style-type: none"> • Junction • Fork connectors |
|--------------------------------------------------------------------------------------------------|-----------------------------------------------------------------------------------------|

Style number

Specification Information		
Height	Style Number	U.S. Price

L Panel Junctions

6"	TS76TLPJS	\$450
12"	TS712TLPJS	\$450
18"	TS718TLPJS	\$450
24"	TS724TLPJS	\$450
·	·	·

T Panel Junctions

6"	TS76TTPJS	\$450
12"	TS712TTPJS	\$450
18"	TS718TTPJS	\$450
24"	TS724TTPJS	\$450
·	·	·

X Panel Junctions

6"	TS76XPJS	\$461
12"	TS712XPJS	\$461
18"	TS718XPJS	\$486
24"	TS724XPJS	\$484
·	·	·

V Panel Junctions

6"	TS76TVPJS	\$569
12"	TS712TVPJS	\$569
18"	TS718TVPJS	\$569
24"	TS724TVPJS	\$569
·	·	·

Y Panel Junctions

6"	TS76YPJS	\$610
12"	TS712YPJS	\$610
18"	TS718YPJS	\$610
24"	TS724YPJS	\$626
·	·	·



For Canadian Pricing
 Multiply U.S. Price by the Canadian price factor.
 ▶ See page 1 for details.

Utility Pole – L, T, and X—Thin Trim



Tip: Works with L, T, or X base junctions of any height and T or X change-of-height junctions as long as at least two panels are at the tallest height.

Tip: For end-of-run utility pole application, the square trim junction utility pole may be used.

Note: this will add 3" of dimension to the application.
 ▶ Page 418

Tip: Cannot be used with L change-of-height junctions.

Tip: Can only be used with junctions manufactured on or after October 10, 2011.

Tip: Does not include junction. Junction is ordered separately.

Tip: Order multipurpose power infeed separately.
 ▶ Page 492

Standard Includes		Required to Specify
▶ Need help? Product details, page 170	<ul style="list-style-type: none"> Utility pole: paint price group 1 Ceiling trim plate: white paint only Mounting brackets 	1 Style number 2 Paint color number for utility pole 3 Options, if selected (see below) ▶ See <i>Surface Materials</i> , page 668.

Options	U.S. Price	Required to Specify
Surface Materials	<ul style="list-style-type: none"> Paint price group 1 Paint price group 2 Paint price group 3 	No cost +\$16 +\$34 Specify paint color number. Specify paint color number. Specify paint color number.

Specification Information		
Configuration	Style Number	U.S. Base Price
L, T, or X junctions	TS7TJUP	\$270

 **For Canadian Pricing**
 Multiply U.S. Price by the Canadian price factor.
 ▶ See page 1 for details.

Utility Packages

Ceiling-Access Lay-In Utility Packages—Thin Trim

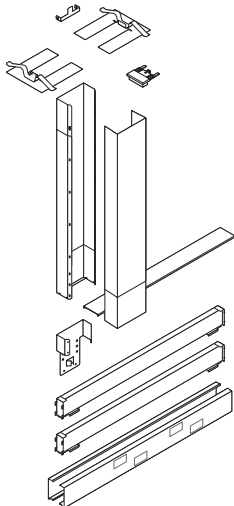

Tip: Order multipurpose power infeed separately.
▶ Page 492

Standard Includes	Required to Specify
-------------------	---------------------

- | | | |
|------------------------------------------------------------------------------------------|-------------------------------------------------------------------------------------------------------------------------------------------------------------------------------------------------------------------------------------------------------------------------------------------------------------------|-------------------------------------------------------------------------------------------------------------------------------------------------------------------------------------------------------------------------------------------------------------------|
| <ul style="list-style-type: none"> ▶ Need help? Product details, page 166 | <ul style="list-style-type: none"> • Utility carrier and cover, one top cap, and two standard base trims: paint price group 1 • Two lay-in horizontal connecting bars: black paint only • Ceiling attachment hardware • Junction cap for end-of-run applications: paint | <ul style="list-style-type: none"> 1 Style number 2 Paint color number for utility carrier and cover, top cap, base trim, and junction cap 3 Options, if selected (see below) ▶ See <i>Surface Materials</i>, page 668. |
|------------------------------------------------------------------------------------------|-------------------------------------------------------------------------------------------------------------------------------------------------------------------------------------------------------------------------------------------------------------------------------------------------------------------|-------------------------------------------------------------------------------------------------------------------------------------------------------------------------------------------------------------------------------------------------------------------|

Options	U.S. Price	Required to Specify
---------	------------	---------------------

Surface Materials	<ul style="list-style-type: none"> • Paint price group 1 No cost • Paint price group 2 +\$ 16 • Paint price group 3 +\$ 34 	<ul style="list-style-type: none"> Specify paint color number. Specify paint color number. Specify paint color number.
Top cap		
<ul style="list-style-type: none"> • Wood group 1 +\$277 • Customiz stain on wood No cost 		<ul style="list-style-type: none"> Specify <i>with wood top cap</i> and select wood color number. Specify <i>with Customiz stain</i>.
Change-of-Height Top Cap	<ul style="list-style-type: none"> • Change-of-height at one end of top cap, slim +\$ 7 • Change-of-height at one end of top cap, cable management +\$ 7 	<ul style="list-style-type: none"> Specify <i>with change-of-height, one end slim</i>. Specify <i>with change-of-height, one end cable management</i>.
Base Cable Tray	<ul style="list-style-type: none"> • Base cable tray +\$ 5 	<ul style="list-style-type: none"> Specify <i>with base cable tray</i>.

Specification Information		
Width	Style Number	U.S. Base Price

30"	TS730TSUC	\$1231
36"	TS736TSUC	\$1300
42"	TS742TSUC	\$1419
48"	TS748TSUC	\$1548
:	:	:



For Canadian Pricing
Multiply U.S. Price by the Canadian price factor.
▶ See page 1 for details.

Floor-Access Lay-In Utility Packages—Thin Trim

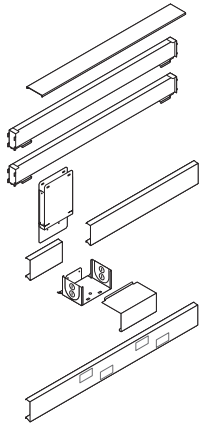

Tip: 30"W lay-in utility package with floor-access is only available with change-of-height top cap at one end.

Tip: Order multipurpose power infeed separately.
▶ Page 492

Standard Includes	Required to Specify
<ul style="list-style-type: none"> ▶ Need help? Product details, page 168 • One top cap, one standard base trim, one modified base trim, and one base utility box: paint price group 1 • Two lay-in horizontal connecting bars: black paint only 	<ul style="list-style-type: none"> 1 Style number 2 Paint color number for top cap, base trim, and base utility box 3 Options, if selected (see below) ▶ See <i>Surface Materials</i>, page 668.

Options	U.S. Price	Required to Specify
Surface Materials <ul style="list-style-type: none"> • Paint price group 1 • Paint price group 2 • Paint price group 3 	<ul style="list-style-type: none"> No cost +\$ 16 +\$ 34 	<ul style="list-style-type: none"> Specify paint color number. Specify paint color number. Specify paint color number.
Top cap <ul style="list-style-type: none"> • Wood group 1 • Customiz stain on wood 	<ul style="list-style-type: none"> +\$277 No cost 	<ul style="list-style-type: none"> Specify with <i>wood top cap</i> and select wood color number. Specify with <i>Customiz stain</i>.

Change-of-Height Top Cap	U.S. Price	Required to Specify
<ul style="list-style-type: none"> • Change-of-height at one end of top cap, slim • Change-of-height at one end of top cap, cable management • Change-of-height at both ends of top cap on 36" - 48"W packages, slim • Change-of-height at both ends of top cap on 36" - 48"W packages, cable management • Change-of-height at both ends of top cap on 36" - 48"W packages, 1 end slim and one end cable management 	<ul style="list-style-type: none"> +\$ 7 +\$ 7 +\$ 7 +\$ 7 +\$ 7 	<ul style="list-style-type: none"> Specify with <i>change-of-height, one end slim</i>. Specify with <i>change-of-height, one end cable management</i>. Specify with <i>change-of-height, both ends slim</i>. Specify with <i>change-of-height, both ends cable management</i>. Specify with <i>change-of-height, one end slim, one end cable management</i>.

Specification Information		
Width	Style Number	U.S. Base Price
30"	TS730TSUF	\$750
36"	TS736TSUF	\$796
42"	TS742TSUF	\$861
48"	TS748TSUF	\$943
:	:	:

 **For Canadian Pricing**
Multiply U.S. Price by the Canadian price factor.
▶ See page 1 for details.

End-of-Run Vertical Trims—Thin Trim



Tip: When ordering vertical trim for a stacking application remember to specify it to span the full height of the base junction plus the stacking junction.

Tip: Thin vertical trim cannot be mixed with square and oval trim on an application. Thin trim must be used on the entire application.

Standard Includes	Required to Specify
<ul style="list-style-type: none"> ▶ Need help? Product details, page 37 • Trim: paint price group 1 or wood group 1 • Aligner 	<ul style="list-style-type: none"> 1 Style number 2 Paint or wood color number for trim 3 Options, if selected (see below) ▶ See <i>Surface Materials</i>, page 668.

Options	U.S. Price	Required to Specify
Surface Materials <ul style="list-style-type: none"> • Paint price group 1 • Paint price group 2 • Paint price group 3 	No cost	Specify paint color number.
	+\$16	Specify paint color number.
	+\$34	Specify paint color number.
<ul style="list-style-type: none"> • Customiz stain on wood 	No cost	Specify with <i>Customiz stain</i> .

Specification Information

Corresponding Panel Height	Style Number	U.S. Base Price	Style Number	U.S. Base Price
Painted Trim		Wood Trim		
30"	TS730TEVT	\$ 97	TS730TEVTW	\$412
36"	TS736TEVT	\$ 97	TS736TEVTW	\$412
42"	TS742TEVT	\$ 97	TS742TEVTW	\$412
48"	TS748TEVT	\$ 97	TS748TEVTW	\$412
54"	TS754TEVT	\$ 97	TS754TEVTW	\$412
60"	TS760TEVT	\$ 97	TS760TEVTW	\$412
66"	TS766TEVT	\$ 97	TS766TEVTW	\$412
72"	TS772TEVT	\$121	TS772TEVTW	\$518
78"	TS778TEVT	\$121	TS778TEVTW	\$518
84"	TS784TEVT	\$132	TS784TEVTW	\$584
90"	TS790TEVT	\$132	TS790TEVTW	\$584
:	:	:	:	:



For Canadian Pricing
 Multiply U.S. Price by the Canadian price factor.
 ▶ See page 1 for details.

L and T Vertical Trims—Thin Trim

Tip: When ordering vertical trim for a stacking application remember to specify it to span the full height of the base junction plus the stacking junction.

Tip: Thin vertical trim cannot be mixed with square or oval trim on an application. Thin trim must be used on the entire application.

Standard Includes	Required to Specify
-------------------	---------------------

- | | | |
|---------------------------------------------|---------------------------------------------|---------------------------------------------------------------------------------------------------------------------------------------------|
| ▶ Need help?
Product details,
page 37 | • Trim: paint price group 1 or wood group 1 | 1 Style number
2 Paint or wood color number for trim
3 Options, if selected (see below)
▶ See <i>Surface Materials</i> , page 668. |
|---------------------------------------------|---------------------------------------------|---------------------------------------------------------------------------------------------------------------------------------------------|

Options	U.S. Price	Required to Specify
---------	------------	---------------------

Surface Materials	• Paint price group 1	No cost	Specify paint color number. Specify paint color number. Specify paint color number.
	• Paint price group 2	+\$16	
	• Paint price group 3	+\$34	
	• Customiz stain on wood	No cost	Specify <i>with Customiz stain</i> .

Specification Information				
Corresponding Panel Height	Style Number	U.S. Base Price	Style Number	U.S. Base Price

	Painted L Vertical Trim		Wood L Vertical Trim	
30"	TS730TLVT	\$ 97	TS730TLVTW	\$412
36"	TS736TLVT	\$ 97	TS736TLVTW	\$412
42"	TS742TLVT	\$ 97	TS742TLVTW	\$412
48"	TS748TLVT	\$ 97	TS748TLVTW	\$412
54"	TS754TLVT	\$ 97	TS754TLVTW	\$412
60"	TS760TLVT	\$ 97	TS760TLVTW	\$412
66"	TS766TLVT	\$ 97	TS766TLVTW	\$412
72"	TS772TLVT	\$121	TS772TLVTW	\$518
78"	TS778TLVT	\$121	TS778TLVTW	\$518
84"	TS784TLVT	\$132	TS784TLVTW	\$584
90"	TS790TLVT	\$132	TS790TLVTW	\$584

	Painted T Vertical Trim		Wood T Vertical Trim	
30"	TS730TTVT	\$ 97	TS730TTVTW	\$412
36"	TS736TTVT	\$ 97	TS736TTVTW	\$412
42"	TS742TTVT	\$ 97	TS742TTVTW	\$412
48"	TS748TTVT	\$ 97	TS748TTVTW	\$412
54"	TS754TTVT	\$ 97	TS754TTVTW	\$412
60"	TS760TTVT	\$ 97	TS760TTVTW	\$412
66"	TS766TTVT	\$ 97	TS766TTVTW	\$412
72"	TS772TTVT	\$121	TS772TTVTW	\$518
78"	TS778TTVT	\$121	TS778TTVTW	\$518
84"	TS784TTVT	\$132	TS784TTVTW	\$584
90"	TS790TTVT	\$132	TS790TTVTW	\$584

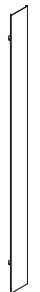

For Canadian Pricing
Multiply U.S. Price by the Canadian price factor.
▶ See page 1 for details.

V Vertical Trims—Thin Trim



Tip: When ordering vertical trim for a stacking application remember to specify it to span the full height of the base junction plus the stacking junction.

Tip: Thin vertical trim cannot be mixed with square and oval trim on an application. Thin trim must be used on the entire application.

Standard Includes	Required to Specify
<ul style="list-style-type: none"> ▶ Need help? Product details, page 38 • Trim: paint price group 1 or wood group 1 	<ul style="list-style-type: none"> 1 Style number 2 Paint or wood color number for trim 3 Options, if selected (see below) ▶ See <i>Surface Materials</i>, page 668.

Options	U.S. Price	Required to Specify
Surface Materials <ul style="list-style-type: none"> • Paint price group 1 • Paint price group 2 • Paint price group 3 	No cost	Specify paint color number.
	+\$16	Specify paint color number.
	+\$34	Specify paint color number.
<ul style="list-style-type: none"> • Customiz stain on wood 	No cost	Specify <i>with Customiz stain</i> .

Specification Information

Corresponding Panel Height	Style Number	U.S. Base Price	Style Number	U.S. Base Price
Painted Trim		Wood Trim		
30"	TS730TVVT	\$120	TS730TVVTW	\$460
36"	TS736TVVT	\$120	TS736TVVTW	\$460
42"	TS742TVVT	\$120	TS742TVVTW	\$460
48"	TS748TVVT	\$120	TS748TVVTW	\$460
54"	TS754TVVT	\$120	TS754TVVTW	\$460
60"	TS760TVVT	\$120	TS760TVVTW	\$460
66"	TS766TVVT	\$120	TS766TVVTW	\$460
72"	TS772TVVT	\$146	TS772TVVTW	\$567
78"	TS778TVVT	\$146	TS778TVVTW	\$567
84"	TS784TVVT	\$155	TS784TVVTW	\$630
90"	TS790TVVT	\$155	TS790TVVTW	\$630
:	:	:	:	:



For Canadian Pricing
 Multiply U.S. Price by the Canadian price factor.
 ▶ See page 1 for details.

End-of-Run/In-Line Change-of-Height Trims—Thin Trim

End-of-Run/In-Line
Change-of-Height
Trims—Thin Trim



Tip: Thin change-of-height trim cannot be used with square or oval top trim.

Standard Includes		Required to Specify
<ul style="list-style-type: none"> ▶ Need help? Product details, page 38 	<ul style="list-style-type: none"> • Trim: paint price group 1 or wood group 1 • Aligner 	<ul style="list-style-type: none"> 1 Style number 2 Paint or wood color number for trim 3 Options, if selected (see below) ▶ See <i>Surface Materials</i>, page 668.

Options	U.S. Price	Required to Specify
Surface Materials	<ul style="list-style-type: none"> • Paint price group 1: No cost • Paint price group 2: +\$16 • Paint price group 3: +\$34 	<ul style="list-style-type: none"> Specify paint color number. Specify paint color number. Specify paint color number.
<ul style="list-style-type: none"> • Customiz stain on wood 	No cost	Specify <i>with Customiz stain</i> .

Specification Information

Corresponding Panel Height	Style Number	U.S. Base Price
:	:	:

Painted Trim

6"	TS76TICHT	\$ 90
12"	TS712TICHT	\$ 90
18"	TS718TICHT	\$ 90
24"	TS724TICHT	\$ 90
30"	TS730TICHT	\$ 97
36"	TS736TICHT	\$ 97
:	:	:

Wood Trim

6"	TS76TICHTW	\$327
12"	TS712TICHTW	\$327
18"	TS718TICHTW	\$327
24"	TS724TICHTW	\$327
30"	TS730TICHTW	\$332
36"	TS736TICHTW	\$332
:	:	:



For Canadian Pricing
Multiply U.S. Price by the Canadian price factor.
▶ See page 1 for details.

90° Corner Application Change-of-Height Trims—Thin Trim

Tip: Thin change-of-height trim cannot be used with square or oval top trim.

Standard Includes	Required to Specify
<ul style="list-style-type: none"> ▶ Need help? Product details, pages 38–39 • Trim: paint price group 1 or wood group 1 	<ul style="list-style-type: none"> 1 Style number 2 Paint or wood color number for trim 3 Options, if selected (see below) ▶ See <i>Surface Materials</i>, page 668.

Options	U.S. Price	Required to Specify
Surface Materials <ul style="list-style-type: none"> • Paint price group 1 • Paint price group 2 • Paint price group 3 	No cost +\$16 +\$34	Specify paint color number. Specify paint color number. Specify paint color number.
<ul style="list-style-type: none"> • Customiz stain on wood 	No cost	Specify with <i>Customiz stain</i> .

Specification Information

Corresponding Panel Height	Style Number	U.S. Base Price	Style Number	U.S. Base Price
Painted Trim		Wood Trim		
L Corner Change-of-Height Trim				
6"	TS76TCLCHT	\$90	TS76TCLCHTW	\$327
12"	TS712TCLCHT	\$90	TS712TCLCHTW	\$327
18"	TS718TCLCHT	\$90	TS718TCLCHTW	\$327
24"	TS724TCLCHT	\$90	TS724TCLCHTW	\$327
30"	TS730TCLCHT	\$97	TS730TCLCHTW	\$332
36"	TS736TCLCHT	\$97	TS736TCLCHTW	\$332
T Corner Change-of-Height Trim				
6"	TS76TCTCHT	\$90	TS76TCTCHTW	\$327
12"	TS712TCTCHT	\$90	TS712TCTCHTW	\$327
18"	TS718TCTCHT	\$90	TS718TCTCHTW	\$327
24"	TS724TCTCHT	\$90	TS724TCTCHTW	\$327
30"	TS730TCTCHT	\$97	TS730TCTCHTW	\$332
36"	TS736TCTCHT	\$97	TS736TCTCHTW	\$332



For Canadian Pricing
 Multiply U.S. Price by the Canadian price factor.
 ▶ See page 1 for details.

120° Corner Application Change-of-Height Trims—Thin Trim

120° Corner Application
Change-of-Height Trims—
Thin Trim

Tip: Thin change-of-height trim cannot be used with square or oval top trim.

Standard Includes	Required to Specify
<ul style="list-style-type: none"> ▶ Need help? Product details, page 39 • Trim: paint price group 1 or wood group 1 	<ul style="list-style-type: none"> 1 Style number 2 Paint or wood color number for trim 3 Options, if selected (see below) ▶ See <i>Surface Materials</i>, page 668.

Options	U.S. Price	Required to Specify
Surface Materials <ul style="list-style-type: none"> • Paint price group 1 • Paint price group 2 • Paint price group 3 	No cost	Specify paint color number.
	+\$16	Specify paint color number.
<ul style="list-style-type: none"> • Customiz stain on wood 	+\$34	Specify paint color number.
	No cost	Specify <i>with Customiz stain</i> .

Specification Information

Corresponding Panel Height	Style Number	U.S. Base Price	Style Number	U.S. Base Price
----------------------------	--------------	-----------------	--------------	-----------------

Painted Trim	Wood Trim
--------------	-----------

120° Corner Change-of-Height Trim

6"	TS76T120CHT	\$90	TS76T120CHTW	\$327
12"	TS712T120CHT	\$90	TS712T120CHTW	\$327
18"	TS718T120CHT	\$90	TS718T120CHTW	\$327
24"	TS724T120CHT	\$90	TS724T120CHTW	\$327
30"	TS730T120CHT	\$97	TS730T120CHTW	\$332
36"	TS736T120CHT	\$97	TS736T120CHTW	\$332

V Corner Change-of-Height Trim

6"	TS76TVCHT	\$90	TS76TVCHTW	\$327
12"	TS712TVCHT	\$90	TS712TVCHTW	\$327
18"	TS718TVCHT	\$90	TS718TVCHTW	\$327
24"	TS724TVCHT	\$90	TS724TVCHTW	\$327
30"	TS730TVCHT	\$97	TS730TVCHTW	\$332
36"	TS736TVCHT	\$97	TS736TVCHTW	\$332



For Canadian Pricing
Multiply U.S. Price by the Canadian price factor.
▶ See page 1 for details.

Build Your Own Junction Components—Thin Trim

Junction Posts



Tip: Junction post can be used at an end-of-run configuration or to change a junction application between an L, T, X, V, or Y.

Tip: Junction block to post fasteners are included with junction blocks. For additional fasteners order part number T521882MP (quantity 50).

Standard Includes	Required to Specify
<ul style="list-style-type: none"> Need help? Product details, page 35 Junction post 	Style number

Specification Information		
Height	Style Number	U.S. Price
30"	TS730JP	\$ 73
36"	TS736JP	\$ 73
42"	TS742JP	\$ 73
48"	TS748JP	\$ 73
54"	TS754JP	\$ 73
66"	TS766JP	\$ 73
78"	TS778JP	\$102

Gripper Glide Caps



Tip: Gripper glide caps only work on glides of junctions that were manufactured on or after October 10, 2011.

Standard Includes	Required to Specify
<ul style="list-style-type: none"> Package of 10 gripper glide caps: soft black plastic only 	Style number

Specification Information	
Style Number	U.S. Price
TS7GGC10	\$63



For Canadian Pricing
 Multiply U.S. Price by the Canadian price factor.
 ▶ See page 1 for details.

Junction Blocks

Tip: When determining the number of junction blocks needed in a same-height corner, start with your lowest panel height. If the lowest height is 48" or less, start with 2 blocks. If the lowest height is 54" to 78" start with 3 blocks.

Tip: When determining the number of blocks needed in a change-of-height corner, please see page 41, How to Build Your Own Change-of-Height Applications.



Standard Includes	Required to Specify
<ul style="list-style-type: none"> ▶ Need help? Product details, page 35 • Junction blocks • Fasteners 	Style number

Specification Information

Application	Package Quantity	Style Number	U.S. Price
90°	3	TS790JB3	\$ 48
90°	4	TS790JB4	\$ 63
90°	5	TS790JB5	\$ 81
120°	3	TS7120JB3	\$ 73
120°	4	TS7120JB4	\$ 97
120°	5	TS7120JB5	\$120

Inside Corner Light Seals



Standard Includes	Required to Specify
<ul style="list-style-type: none"> ▶ Need help? Product details, page 35 • Inside corner light seal, package of four: black plastic 	Style number

Specification Information

Height	Style Number	U.S. Price
54"	TS754ICLS	\$31
66"	TS766ICLS	\$31
78"	TS778ICLS	\$31

Tip: Inside corner light seals can be field cut for use on shorter panels.



For Canadian Pricing

Multiply U.S. Price by the Canadian price factor.

▶ See page 1 for details.

Build Your Own Junction Components—Thin Trim, continued

Junction Caps

Tip: Aligners are specified separately.

Tip: 90° corner and 90° change-of-height corner junction cap include no aligners. All are specified separately.

Tip: 120° corner junction cap includes one integral aligner. Additional aligners are specified separately.

Standard Includes	Required to Specify
<ul style="list-style-type: none"> ▶ Need help? Product details, page 36 • Junction cap: paint or wood group 1 	<ul style="list-style-type: none"> 1 Style number 2 Paint or wood color number for junction cap 3 Options, if selected (see below) ▶ See <i>Surface Materials</i>, page 668.

Options	U.S. Price	Required to Specify
Surface Materials <ul style="list-style-type: none"> • Paint price group 1 • Paint price group 2 • Paint price group 3 	<ul style="list-style-type: none"> No cost No cost No cost 	<ul style="list-style-type: none"> Specify paint color number. Specify paint color number. Specify paint color number.
<ul style="list-style-type: none"> • Customiz stain on wood 	<ul style="list-style-type: none"> No cost 	<ul style="list-style-type: none"> Specify with <i>Customiz stain</i>.

Specification Information				
Corresponding Panel Application	Style Number	U.S. Price	Style Number	U.S. Price

	Painted Junction Cap		Wood Junction Cap	
90° corner	TS790JC	\$17	TS790JCW	\$124
120° corner	TS7120JC	\$17	TS7120JCW	\$124
90° change-of-height corner	TS790COHJC	\$17	TS790COHJCW	\$124
:	:	:	:	:

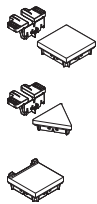

For Canadian Pricing
 Multiply U.S. Price by the Canadian price factor.
 ▶ See page 1 for details.

Junction Cap and Trim Aligners

Standard Includes	Required to Specify
<ul style="list-style-type: none"> Need help? Product details, page 36 Junction cap aligner or vertical trim aligner 	Style number

Specification Information			
Description	Package Quantity	Style Number	U.S. Price

Junction Cap Aligner

Corner aligner	10	TS7CJCA10	\$111
----------------	----	------------------	-------

Vertical Trim Aligners

L to T aligner	4	TS7LTA4	\$ 31
----------------	---	----------------	-------

120° to V aligner	4	TS7120VA4	\$ 31
-------------------	---	------------------	-------



 **For Canadian Pricing**
Multiply U.S. Price by the Canadian price factor.
▶ See page 1 for details.

Base Horizontal Frame Packages— Thin Trim and Big Open Base Trim Package

For Panel Buildups

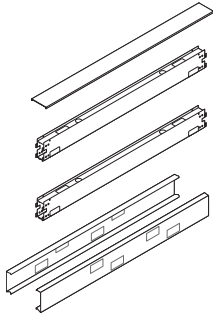

Tip: You must order vertical junctions separately to complete your frame.

▶ See page 322.

Tip: Specify omit top cap when adding a frameless glass screen to a panel or when ordering spanning top caps.

Tip: Change-of-height top caps are only required in an in-line change-of-height application.

Tip: Remember to omit base trim(s) when using skins to the floor.

Tip: Omit base trim and separately specify hardware base trims when accessing hardware power in the base.

Tip: When open base trim or big open base option is selected, both base trims are omitted.

Tip: Base cable tray cannot be used if open base or big open base is selected, or if omit base trim is selected for one or both sides of panel.

Tip: Remember to order skins to complete the panel.

▶ See page 436.



For Canadian Pricing

Multiply U.S. Price by the Canadian price factor.

▶ See page 1 for details.

Standard Includes	Required to Specify
<ul style="list-style-type: none"> ▶ Need help? Product details, page 58 • Standard length top cap: color default determined by base trim paint color • Base trim with no knockouts (on 18"W): paint price group 1 • Base trim with knockouts (24"W to 72"W): paint price group 1 • Two horizontal connecting bars: black paint only 	<ul style="list-style-type: none"> 1 Style number 2 Paint or wood color number for trim 3 Options, if selected (see below) ▶ See <i>Surface Materials</i>, page 668.

Options	U.S. Price	Required to Specify
Surface Materials <ul style="list-style-type: none"> • Paint price group 1 • Paint price group 2 • Paint price group 3 	<ul style="list-style-type: none"> No cost +\$16 +\$34 	<ul style="list-style-type: none"> Specify paint color number. Specify paint color number. Specify paint color number.
Top cap <ul style="list-style-type: none"> • Omit top cap • Wood • Customiz stain on wood 	<ul style="list-style-type: none"> No cost Prices at right No cost 	<ul style="list-style-type: none"> Specify <i>omit top cap</i>. Specify <i>with wood top cap</i> and select wood color number. Specify <i>with Customiz stain</i>.
Change-of-Height Top Cap <ul style="list-style-type: none"> • Change-of-height at one end of top cap • Change-of-height at both ends of top cap on 36"W and wider packages 	<ul style="list-style-type: none"> +\$ 7 +\$ 7 	<ul style="list-style-type: none"> Specify <i>with change-of-height, one end</i>. Specify <i>with change-of-height, both ends</i>.
Base Trim <ul style="list-style-type: none"> • Knockouts one side, plain one side (24"W to 72"W only) • Plain both sides (24"W to 72"W only) • Omit one side, knockouts one side, 24"W to 36"W • Omit one side, knockouts one side, 42"W to 48"W • Omit one side, knockouts one side, 60"W to 72"W • Omit one side, plain one side, 18"W to 36"W • Omit one side, plain one side, 42"W to 48"W • Omit one side, plain one side, 60"W to 72"W • Omit both sides, 18"W to 36"W • Omit both sides, 42"W to 48"W • Omit both sides, 60"W to 72"W 	<ul style="list-style-type: none"> No cost No cost -\$ 3 -\$ 4 -\$ 5 -\$ 3 -\$ 4 -\$ 5 -\$ 6 -\$ 8 -\$10 	<ul style="list-style-type: none"> Specify <i>with knockouts one side, plain one side</i>. Specify <i>with plain both sides</i>. Specify <i>with omit one side, knockouts one side</i>. Specify <i>with omit one side, knockouts one side</i>. Specify <i>with omit one side, knockouts one side</i>. Specify <i>with omit one side, plain one side</i>. Specify <i>with omit one side, plain one side</i>. Specify <i>with omit one side, plain one side</i>. Specify <i>with omit both sides</i>. Specify <i>with omit both sides</i>. Specify <i>with omit both sides</i>.
Open Base Trim <ul style="list-style-type: none"> • Open base 	<ul style="list-style-type: none"> No cost 	<ul style="list-style-type: none"> Specify <i>with open base</i>.
Big Open Base <ul style="list-style-type: none"> • Big open base 	<ul style="list-style-type: none"> +\$98 	<ul style="list-style-type: none"> Specify <i>with big open base</i>.
Cable Tray <ul style="list-style-type: none"> • Cable tray 	<ul style="list-style-type: none"> No cost 	<ul style="list-style-type: none"> Specify <i>with cable tray</i>.
Base Cable Tray <ul style="list-style-type: none"> • Base cable tray 	<ul style="list-style-type: none"> +\$ 5 	<ul style="list-style-type: none"> Specify <i>with base cable tray</i>.

Base Horizontal Frame Packages—Thin Trim and Big Open Base Trim Package

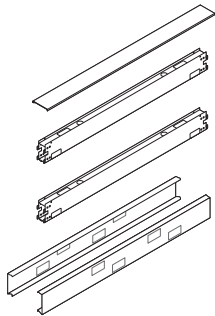

Specification Information

Width	Style Number	U.S. Base Price	Option (Add \$ to Base Price)
18"	TS718THF	\$113	+\$277
24"	TS724THF	\$120	+\$277
30"	TS730THF	\$129	+\$277
36"	TS736THF	\$136	+\$277
42"	TS742THF	\$157	+\$277
48"	TS748THF	\$165	+\$277
60"	TS760THF	\$209	+\$365
72"	TS772THF	\$288	+\$365

Big Open Base Trim Package

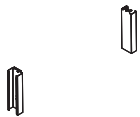

Standard Includes **Required to Specify**

- | | | |
|-----------------------------------------------------------------------------------------|---------------------------------------------------------------------------------------------------|--------------------------------------------------------------------------------------------------------------------------------------------------------------------------------------------------------|
| <ul style="list-style-type: none"> ▶ Need help? Product details, page 58 | <ul style="list-style-type: none"> • Two inside vertical trim: paint price group 1 | <ul style="list-style-type: none"> 1 Style number 2 Paint color number for trim 3 Options, if selected (see below) ▶ See <i>Surface Materials</i>, page 668. |
|-----------------------------------------------------------------------------------------|---------------------------------------------------------------------------------------------------|--------------------------------------------------------------------------------------------------------------------------------------------------------------------------------------------------------|

Options **U.S. Price** **Required to Specify**

Options	U.S. Price	Required to Specify
Surface Materials	<ul style="list-style-type: none"> • Paint price group 1: No cost • Paint price group 2: +\$16 • Paint price group 3: +\$34 	<ul style="list-style-type: none"> Specify paint color number. Specify paint color number. Specify paint color number.

Specification Information

Style Number	U.S. Base Price
TSBBOBTRM	\$106

 **For Canadian Pricing**
 Multiply U.S. Price by the Canadian price factor.
 ▶ See page 1 for details.

Stacking Horizontal Frame Packages

For Panel Buildups

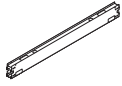

Tip: You must order vertical stacking junctions separately to complete your frame.

▶ Page 402

Tip: Top cap is not included. Use the top cap from the base panel you are stacking on.

Tip: If stacking a window kit, stacking horizontal frame package is not needed.

Tip: Remember to order skins to complete the panel.

▶ Page 436

Standard Includes	Required to Specify
-------------------	---------------------

- | | |
|---------------------------------------------|-----------------------------------------------------------------------|
| ▶ Need help?
Product details,
page 62 | • One horizontal connecting bar: black paint only

Style number |
|---------------------------------------------|-----------------------------------------------------------------------|

Specification Information

Width	Style Number	U.S. Price
18"	TS718HFS	\$26
24"	TS724HFS	\$31
30"	TS730HFS	\$32
36"	TS736HFS	\$34
42"	TS742HFS	\$37
48"	TS748HFS	\$44
60"	TS760HFS	\$51
72"	TS772HFS	\$75
:	:	:



For Canadian Pricing

Multiply U.S. Price by the Canadian price factor.

▶ See page 1 for details.

Spanning Top Caps—Thin Trim

For Panel Buildups

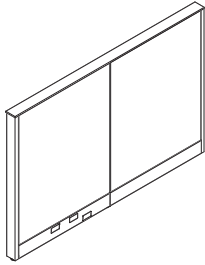

Tip: In-line spanning top cap lightseals should be specified for each in-line joint top cap it is spanning across.
▶ See page 477.

Standard Includes		Required to Specify
▶ Need help? Product details, page 59	• Top cap: paint or wood group 1	1 Style number 2 Paint or wood color number for top cap 3 Options, if selected (see below) ▶ See <i>Surface Materials</i> , page 668.

Options	U.S. Price	Required to Specify
Surface Materials • Customiz stain on wood	No cost	Specify with <i>Customiz stain</i> .
Change-of-Height Top Cap • Change-of-height at one end of top cap • Change-of-height at both ends of top cap	+\$7 +\$7	Specify with <i>change-of-height, one end</i> . Specify with <i>change-of-height, both ends</i> .

Specification Information				
Width	Style Number	U.S. Base Price	Style Number	U.S. Base Price
	Painted Top Cap		Wood Top Cap	
36"	TS736TTC	\$ 28	TS736TTCW	\$305
42"	TS742TTC	\$ 34	TS742TTCW	\$311
48"	TS748TTC	\$ 44	TS748TTCW	\$321
54"	TS754TTC	\$ 49	TS754TTCW	\$414
60"	TS760TTC	\$ 50	TS760TTCW	\$415
66"	TS766TTC	\$ 56	TS766TTCW	\$421
72"	TS772TTC	\$ 58	TS772TTCW	\$423
78"	TS778TTC	\$ 73	TS778TTCW	\$438
84"	TS784TTC	\$ 85	TS784TTCW	\$450
90"	TS790TTC	\$ 97	TS790TTCW	\$462
96"	TS796TTC	\$109	TS796TTCW	\$474
:	:	:	:	:

 **For Canadian Pricing**
Multiply U.S. Price by the Canadian price factor.
▶ See page 1 for details.

Frameless Glass Screens with Recessed Attachment—Thin Trim

Tip: These screens are only to be used on panels with thin trims.

Tip: Remember to specify in-line spanning top cap lightseals if frameless glass screen is spanning two or more panels.
▶ See page 477.

Tip: Wall start application should be specified when using a wall start junction to attach to a wall or to be used in an off-module condition.

Tip: For widths of 72" or smaller, if spanning glass of two or more junctions, additional junction grommets will be needed. Two grommets per spanned junction should be ordered. Order service part package 89050001MP for a package of 20 grommets.

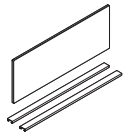

Standard Includes		Required to Specify
▶ Need help? Product details, page 64	<ul style="list-style-type: none"> • Glass screen: 6500 Clear Glass • Two supports for 24"–66" wide • Three supports for 72"–96" wide • Two top caps—thin trim: paint 	1 Style number 2 Paint color number for top caps 3 Options, if selected (see below) ▶ See <i>Surface Materials</i> , page 668.

Options	U.S. Price	Required to Specify	
Surface Materials	Top cap		
<ul style="list-style-type: none"> • Paint price group 1 • Paint price group 2 • Paint price group 3 	No cost +\$16 +\$34	Specify paint color number. Specify paint color number. Specify paint color number.	
<ul style="list-style-type: none"> • Wood group 1 	Prices below and at right	Specify with <i>wood top cap</i> and select wood color number.	
<ul style="list-style-type: none"> • Customiz stain on wood 	No cost	Specify with <i>Customiz stain</i> .	
Change-of-Height Top Cap	<ul style="list-style-type: none"> • Change-of-height at one end of top cap 	+\$ 7	Specify with <i>change-of-height, one end</i> .
Wall Start Application	<ul style="list-style-type: none"> • Wall start application 	No cost	Specify with <i>wall start application</i> .
Glass Screen	<ul style="list-style-type: none"> • Omit glass screen • Frosted glass 	Prices below and at right Prices below and at right	Specify with <i>omit screen</i> . Specify with <i>6530 Frosted Laminated Glass</i> .

Specification Information			
Width	Style Number	U.S. Base Price	Options (Add \$ to Base Price)
.....	Wood : Omit : Frosted Top Cap : Glass : Glass

6"H Recessed Frameless Glass

24"	TS7624TFGR	\$ 499	+\$277	-\$ 89	+\$ 46
30"	TS7630TFGR	\$ 528	+\$277	-\$102	+\$ 62
36"	TS7636TFGR	\$ 560	+\$277	-\$106	+\$107
42"	TS7642TFGR	\$ 586	+\$277	-\$109	+\$162
48"	TS7648TFGR	\$ 613	+\$277	-\$116	+\$178
54"	TS7654TFGR	\$ 654	+\$365	-\$120	+\$203
60"	TS7660TFGR	\$ 700	+\$365	-\$126	+\$230
66"	TS7666TFGR	\$ 735	+\$365	-\$132	+\$250
72"	TS7672TFGR	\$ 768	+\$365	-\$136	+\$270
78"	TS7678TFGR	\$ 850	+\$365	-\$146	+\$281
84"	TS7684TFGR	\$ 933	+\$365	-\$153	+\$287
90"	TS7690TFGR	\$1015	+\$365	-\$162	+\$312
96"	TS7696TFGR	\$1093	+\$365	-\$172	+\$324

▶ Specification Information, continued on next page



For Canadian Pricing
 Multiply U.S. Price by the Canadian price factor.
 ▶ See page 1 for details.

► Specification Information, continued from previous page

Specification Information					
Width	Style Number	U.S. Base Price	Options (Add \$ to Base Price)		
			Wood Top Cap	Omit Glass	Frosted Glass

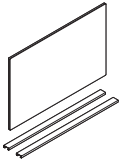

12"H Recessed Frameless Glass

24"	TS71224TFGR	\$ 622	+\$277	-\$112	+\$ 86
30"	TS71230TFGR	\$ 667	+\$277	-\$126	+\$113
36"	TS71236TFGR	\$ 718	+\$277	-\$135	+\$173
42"	TS71242TFGR	\$ 767	+\$277	-\$141	+\$255
48"	TS71248TFGR	\$ 810	+\$277	-\$154	+\$284
54"	TS71254TFGR	\$ 872	+\$365	-\$160	+\$324
60"	TS71260TFGR	\$ 935	+\$365	-\$168	+\$365
66"	TS71266TFGR	\$ 989	+\$365	-\$177	+\$402
72"	TS71272TFGR	\$1044	+\$365	-\$182	+\$438
78"	TS71278TFGR	\$1161	+\$365	-\$198	+\$462
84"	TS71284TFGR	\$1276	+\$365	-\$210	+\$476
90"	TS71290TFGR	\$1394	+\$365	-\$225	+\$526
96"	TS71296TFGR	\$1513	+\$365	-\$239	+\$552

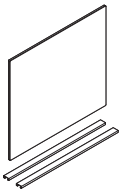

18"H Recessed Frameless Glass

24"	TS71824TFGR	\$ 687	+\$277	-\$124	+\$132
30"	TS71830TFGR	\$ 759	+\$277	-\$143	+\$168
36"	TS71836TFGR	\$ 826	+\$277	-\$154	+\$246
42"	TS71842TFGR	\$ 898	+\$277	-\$163	+\$350
48"	TS71848TFGR	\$ 959	+\$277	-\$182	+\$391
54"	TS71854TFGR	\$1047	+\$365	-\$194	+\$441
60"	TS71860TFGR	\$1135	+\$365	-\$208	+\$494
66"	TS71866TFGR	\$1213	+\$365	-\$216	+\$542
72"	TS71872TFGR	\$1291	+\$365	-\$227	+\$585
78"	TS71878TFGR	\$1445	+\$365	-\$247	+\$615
84"	TS71884TFGR	\$1600	+\$365	-\$264	+\$641
90"	TS71890TFGR	\$1758	+\$365	-\$281	+\$705
96"	TS71896TFGR	\$1916	+\$365	-\$304	+\$739

► Specification Information, continued on next page



For Canadian Pricing
Multiply U.S. Price by the
Canadian price factor.
► See page 1 for details.

Frameless Glass Screens with Recessed Attachment—Thin Trim, continued

► Specification Information, continued from previous page

Specification Information					
Width	Style Number	U.S. Base Price	Options (Add \$ to Base Price)		
			Wood	Omit	Frosted
			Top Cap	Glass	Glass

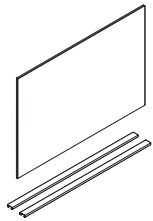

24"H Recessed Frameless Glass

Width	Style Number	U.S. Base Price	Wood Top Cap	Omit Glass	Frosted Glass
24"	TS72424TFGR	\$ 782	+\$277	-\$172	+\$171
30"	TS72430TFGR	\$ 872	+\$277	-\$209	+\$215
36"	TS72436TFGR	\$ 959	+\$277	-\$231	+\$315
42"	TS72442TFGR	\$1052	+\$277	-\$262	+\$400
48"	TS72448TFGR	\$1130	+\$277	-\$296	+\$469
54"	TS72454TFGR	\$1244	+\$365	-\$335	+\$536
60"	TS72460TFGR	\$1357	+\$365	-\$368	+\$603
66"	TS72466TFGR	\$1453	+\$365	-\$397	+\$668
72"	TS72472TFGR	\$1598	+\$365	-\$427	+\$728
78"	TS72478TFGR	\$1695	+\$365	-\$456	+\$768
84"	TS72484TFGR	\$1891	+\$365	-\$519	+\$804
90"	TS72490TFGR	\$2091	+\$365	-\$585	+\$868
96"	TS72496TFGR	\$2285	+\$365	-\$633	+\$907



For Canadian Pricing

Multiply U.S. Price by the Canadian price factor.

► See page 1 for details.

Recessed Frameless Glass Top Cap Connector and Junction Grommets for Frameless Glass—Thin Trim

Recessed Frameless Glass
Top Cap Connector and
Junction Grommets for
Frameless Glass—Thin Trim

Recessed Frameless Glass Top Connector—Thin Trim



Tip: Recessed frameless glass top cap connector needs to be ordered in the following situations:

- when using a wall start junction and putting frameless glass with recessed attachment on the panel directly adjacent to the wall
- when using frameless glass with recessed attachment on an off-module fin panel
- when recessed frameless glass is adjacent to a corner junction and the recessed frameless glass top caps are located at a lower height than the junction cap
- when recessed frameless glass is coming into an in-line change-of-height condition and the recessed frameless glass top caps are located on the lower panel height
- when recessed, frameless glass is adjacent to a utility pole
- when frameless glass or top cap mounted storage is used on a panel that is adjacent to a boundary screen

Standard Includes	Required to Specify
<ul style="list-style-type: none"> ▶ Need help? Product details, page 65 • One recessed frameless glass top cap connector 	Style number

Specification Information	
Style Number	U.S. Price

TS7TFGRC	\$25
----------	------

Junction Grommets for Frameless Glass—Thin Trim

Standard Includes	Required to Specify
<ul style="list-style-type: none"> • Two standard junction grommets 	Style number

Specification Information	
Style Number	U.S. Price

TS7FGJG	\$5
---------	-----



For Canadian Pricing
Multiply U.S. Price by the Canadian price factor.
▶ See page 1 for details.

Frameless Glass Screens with Clip Attachment—Thin Trim

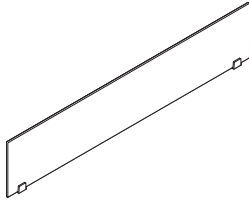

Tip: These screens are only to be used on panels with thin trims.

Tip: Remember to specify in-line spanning top cap lightseals if frameless glass screen is spanning two or more panels.

▶ See page 477.

Standard Includes	Required to Specify
<ul style="list-style-type: none"> ▶ Need help? Product details, page 68 • Glass screen: 6500 Clear Glass • Two brackets, 24"W to 84"W: paint • Three brackets, 90"W to 96"W: paint • Two supports • Thin profile top cap with holes: paint 	<ul style="list-style-type: none"> 1 Style number 2 Paint color number for brackets 3 Paint color number for top cap 4 Options, if selected (see below) ▶ See <i>Surface Materials</i>, page 668.

Options	U.S. Price	Required to Specify
Surface Materials Top cap <ul style="list-style-type: none"> • Paint price group 1 • Paint price group 2 • Paint price group 3 	<ul style="list-style-type: none"> No cost +\$16 +\$34 	<ul style="list-style-type: none"> Specify paint color number. Specify paint color number. Specify paint color number.
<ul style="list-style-type: none"> • Wood group 1 	Prices below	Specify with <i>wood top cap</i> and select wood color number.
<ul style="list-style-type: none"> • Customiz stain on wood 	No cost	Specify with <i>Customiz stain</i> .
Change-of-Height Top Cap <ul style="list-style-type: none"> • Change-of-height at one end of top cap 	+\$ 7	Specify with <i>change-of-height, one end</i> .
Glass Screen <ul style="list-style-type: none"> • Omit glass screen • Frosted glass 	<ul style="list-style-type: none"> Prices below Prices below 	<ul style="list-style-type: none"> Specify with <i>omit screen</i>. Specify with <i>6530 Frosted Tempered Glass</i>.

Specification Information					
Width	Style Number	U.S. Base Price	Options (Add \$ to Base Price)		
			Wood Top Cap	Omit Glass	Frosted Glass
24"	TS71224TFG	\$ 622	+\$277	-\$112	+\$ 86
30"	TS71230TFG	\$ 667	+\$277	-\$126	+\$113
36"	TS71236TFG	\$ 718	+\$277	-\$135	+\$173
42"	TS71242TFG	\$ 767	+\$277	-\$141	+\$255
48"	TS71248TFG	\$ 810	+\$277	-\$154	+\$284
60"	TS71260TFG	\$ 935	+\$365	-\$168	+\$365
72"	TS71272TFG	\$1044	+\$365	-\$182	+\$438
78"	TS71278TFG	\$1161	+\$365	-\$198	+\$462
84"	TS71284TFG	\$1276	+\$365	-\$210	+\$476
90"	TS71290TFG	\$1394	+\$365	-\$225	+\$526
96"	TS71296TFG	\$1513	+\$365	-\$239	+\$552



For Canadian Pricing

Multiply U.S. Price by the Canadian price factor.

▶ See page 1 for details.

Universal and Sarto Screens with Answer Thin Trim Top Cap

For Panel Buildups

Tip: In-line spanning top cap lightseals should be specified for each in-line joint top cap it is spanning across.
▶ See page 372.

Tip: Spanning top caps can also be used on individual panels.

Standard Includes	Required to Specify
<ul style="list-style-type: none"> ▶ Need help? Product details, page 70 • Top cap: paint price group 1 • Screen: fabric price group 1 • Edge on Universal screen: PET 	<ol style="list-style-type: none"> 1 Style number 2 Paint color number for top cap 3 Fabric color number for screen 4 Edge color: <ul style="list-style-type: none"> P630 Medium Heather Grey PET P631 Dark Heather Grey PET 5 Options, if selected (see below) ▶ See <i>Surface Materials</i> , page 668.

Options	U.S. Price	Required to Specify
Surface Materials		
Top cap		
• Paint price group 1	No cost	Specify paint color number.
• Paint price group 2	+\$ 16	Specify paint color number.
• Paint price group 3	+\$ 34	Specify paint color number.
Screen		
• Fabric price group 1	No cost	Specify fabric color number.
• Fabric price group 2	+\$ 49	Specify fabric color number.
• Fabric price group 3	+\$132	Specify fabric color number.
• Fabric price group 4	+\$165	Specify fabric color number.
• Fabric price group 5	+\$202	Specify fabric color number.
• Fabric price group 6	+\$237	Specify fabric color number.
• Fabric price group 7	+\$274	Specify fabric color number.
• Fabric price group 8	+\$307	Specify fabric color number.
• Fabric price group 9	+\$343	Specify fabric color number.
• Fabric price group 10	+\$378	Specify fabric color number.
• Customer's Own Material (COM)	+\$ 23	Specify fabric color number.
		▶ See <i>Surface Materials Reference Manual</i> .

Specification Information					
• Dimensions		• Style	• U.S.	• Style	• U.S.
W	H	Number	Base Price	Number	Base Price

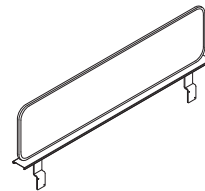
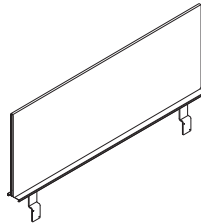

Universal Screens with Answer Thin Trim Top Cap				Sarto Screens with Answer Thin Trim Top Cap	
24"	13½"	TS71324TUSC	\$ 647	TS71324TSSC	\$483
30"	13½"	TS71330TUSC	\$ 692	TS71330TSSC	\$519
36"	13½"	TS71336TUSC	\$ 743	TS71336TSSC	\$556
42"	13½"	TS71342TUSC	\$ 797	TS71342TSSC	\$596
48"	13½"	TS71348TUSC	\$ 847	TS71348TSSC	\$633
54"	13½"	TS71354TUSC	\$ 897	TS71354TSSC	\$673
60"	13½"	TS71360TUSC	\$ 944	TS71360TSSC	\$709
66"	13½"	TS71366TUSC	\$ 995	TS71366TSSC	\$744
72"	13½"	TS71372TUSC	\$1046	TS71372TSSC	\$786

▶ **Specification Information, continued on next page**



For Canadian Pricing
Multiply U.S. Price by the Canadian price factor.
▶ See page 1 for details.

► Specification Information, continued from previous page

Dimensions		Style Number	U.S. Base Price	Style Number	U.S. Base Price
W	H				

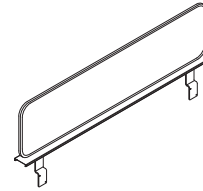
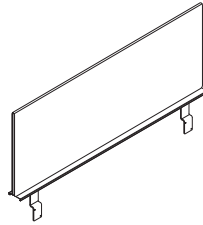

Universal Screens with Answer Thin Trim Top Cap

Sarto Screens with Answer Thin Trim Top Cap

78"	13½"	TS71378TUSC	\$1099	TS71378TSSC	\$ 827
84"	13½"	TS71384TUSC	\$1156	TS71384TSSC	\$ 873
90"	13½"	TS71390TUSC	\$1211	TS71390TSSC	\$ 950
96"	13½"	TS71396TUSC	\$1268	TS71396TSSC	\$ 964
24"	19½"	TS71924TUSC	\$ 737	TS71924TSSC	\$ 549
30"	19½"	TS71930TUSC	\$ 812	TS71930TSSC	\$ 605
36"	19½"	TS71936TUSC	\$ 884	TS71936TSSC	\$ 658
42"	19½"	TS71942TUSC	\$ 962	TS71942TSSC	\$ 717
48"	19½"	TS71948TUSC	\$1042	TS71948TSSC	\$ 776
54"	19½"	TS71954TUSC	\$1116	TS71954TSSC	\$ 832
60"	19½"	TS71960TUSC	\$1189	TS71960TSSC	\$ 887
66"	19½"	TS71966TUSC	\$1264	TS71966TSSC	\$ 943
72"	19½"	TS71972TUSC	\$1341	TS71972TSSC	\$ 998
78"	19½"	TS71978TUSC	\$1419	TS71978TSSC	\$1065
84"	19½"	TS71984TUSC	\$1501	TS71984TSSC	\$1128
90"	19½"	TS71990TUSC	\$1582	TS71990TSSC	\$1234
96"	19½"	TS71996TUSC	\$1660	TS71996TSSC	\$1256



For Canadian Pricing
 Multiply U.S. Price by the Canadian price factor.
 ► See page 1 for details.

Top Cap Mount Storage—Brackets

Tip: Top cap mounted storage can only be used with thin trim panels.

Tip: Brackets will be visible on the bottom of the storage unit. They can be painted to match the panel trim or storage unit.

Standard Includes	Required to Specify
-------------------	---------------------

- | | | |
|------------------------------------------|--------------------------------------------------------------------------------------------------------------------------------------------------------------------------------------------------------------------------------------------------------------------------------------------------------------------------------------------------------------------------------------------------------------------|-------------------------------------------------------------------------------------------------------------------------------------------------------------|
| ▶ Need help?
Product details, page 74 | <ul style="list-style-type: none"> Two support brackets for centered mounted applications, if selected: paint price group 1 Two support brackets for aisleway applications, for use with 30"W to 48" storage units, if selected: paint price group 1 Three support brackets for aisle way applications, for use with 54"W to 72"W storage units, if selected: paint price group 1 | <ul style="list-style-type: none"> 1 Style number 2 Paint color number for bracket <p>▶ See <i>Surface Materials</i>, page 668.</p> |
|------------------------------------------|--------------------------------------------------------------------------------------------------------------------------------------------------------------------------------------------------------------------------------------------------------------------------------------------------------------------------------------------------------------------------------------------------------------------|-------------------------------------------------------------------------------------------------------------------------------------------------------------|

Surface Materials	Options	U.S. Price	Required to Specify
	<ul style="list-style-type: none"> Paint price group 1 Paint price group 2 Paint price group 3 	No cost +\$16 +\$34	Specify paint color number. Specify paint color number. Specify paint color number.

Specification Information

Style Number	U.S. Base Price



Tip: Center mounted applications can accept storage units up to 25"D.

Center Mounted Applications

TS7CMB2	\$474



Tip: Aisleway applications can accept storage units up to 17"D.

Aisleway Applications

For Use with 30"W to 48"W Storage Units

TS7CMBA2	\$474
-----------------	-------

For Use with 54"W to 72"W Storage Units

TS7CMBA3	\$656
-----------------	-------

Tip: Top caps and storage to complete the solution are specified separately.



For Canadian Pricing
 Multiply U.S. Price by the Canadian price factor.
 ▶ See page 1 for details.

Top Cap Mounted Storage—Top Caps and Aligner Packages

Top Cap Mounted Storage
– Top Caps and Aligner Packages

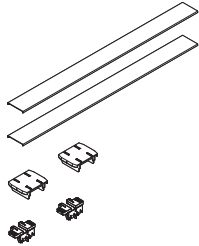

Tip: Top caps should be specified to match the width of the storage unit that is being top cap mounted. They do not necessarily match the width of the panel.

Tip: When top cap mounted storage units are on module with the panel, standard top caps from the horizontal frame package can be omitted. If the top cap mounted storage is being mounted off-module, standard top caps should NOT be omitted from the horizontal frame package.

Tip: Mounting brackets and storage to complete the solution are specified separately.

Standard Includes		Required to Specify
▶ Need help? Product details, page 74	<ul style="list-style-type: none"> • Two top caps – thin trim: paint or wood group 1 • Aligner package: <ul style="list-style-type: none"> – Two end-of-run aligners – Two in-line aligners – One recessed-to-recessed aligner 	1 Style number 2 Paint or wood color number for top cap 3 Options, if selected (see below) ▶ See <i>Surface Materials</i> , page 668.

Surface Materials	Options	U.S. Price	Required to Specify
	Top cap <ul style="list-style-type: none"> • Paint price group 1 • Paint price group 2 • Paint price group 3 	No cost +\$16 +\$34	Specify paint color number. Specify paint color number. Specify paint color number.

Specification Information		
Width	Style Number	U.S. Base Price
...

Top Cap and Aligner Packages—Painted

30"	TS730TTCR	\$ 75
36"	TS736TTCR	\$ 82
42"	TS742TTCR	\$ 85
48"	TS748TTCR	\$ 87
54"	TS754TTCR	\$ 88
60"	TS760TTCR	\$ 90
66"	TS766TTCR	\$ 94
72"	TS772TTCR	\$105
...

Top Cap and Aligner Packages—Wood

30"	TS730TTCWR	\$352
36"	TS736TTCWR	\$359
42"	TS742TTCWR	\$362
48"	TS748TTCWR	\$364
54"	TS754TTCWR	\$365
60"	TS760TTCWR	\$367
66"	TS766TTCWR	\$371
72"	TS772TTCWR	\$382
...

 **For Canadian Pricing**
Multiply U.S. Price by the Canadian price factor.
▶ See page 1 for details.

Panel Packages—Thin Trim

For Panel Buildups

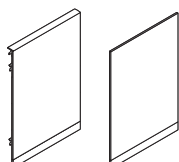

Side 1 Side 2

Tip: You must order junctions separately to connect adjacent panels.

▶ See page 322.

Tip: Remember to order receptacles and faceplates.

▶ See page 484.

Tip: For further information about fabric direction, see page 674.

Tip: 72"W panels accommodate fabric in the horizontal application only.

Tip: Specify omit top cap when adding a frameless glass screen to a panel or when ordering spanning top caps.

Tip: Change-of-height top cap option should be specified only when using an in-line change-of-height application.

Tip: When open base trim option is selected, both base trims are omitted.

Tip: Base cable tray cannot be used if open base trim is selected.

Tip: 18"W panels can accommodate pass-through power only.



For Canadian Pricing

Multiply U.S. Price by the Canadian price factor.

▶ See page 1 for details.

Standard Includes

▶ Need help?
Product details,
page 78



- Tackable acoustical skins on both sides of panel, fabric direction with horizontal application, if selected: fabric price group 1
- Performance tackable acoustical skins on both sides of panel, fabric direction with horizontal application, if selected: fabric price group 1
- Standard length top cap: color default determined by trim paint color
- Base trim with no knockouts (18"W): painted steel
- Base trim with knockouts (24"W to 72"W): painted steel
- Two horizontal connecting bars

Required to Specify

- 1 Style number
 - 2 Fabric color number for side 1
 - 3 Fabric color number for side 2
 - 4 Paint color number for trim
 - 5 Options, if selected (see below)
- ▶ See *Surface Materials*, page 668.

	Options	U.S. Price	Required to Specify
Surface Materials	Skin surface		
	• Fabric price group A each side	–\$ 5	Specify fabric color number.
	• Fabric price group 1 each side	No cost	Specify fabric color number.
	• Fabric price group 2 each side	+\$ 39	Specify fabric color number.
	• Fabric price group 3 each side	+\$ 72	Specify fabric color number.
	• Fabric price group 4 each side	+\$112	Specify fabric color number.
	• Fabric price group 5 each side	+\$174	Specify fabric color number.
	• Fabric price group 6 each side	+\$240	Specify fabric color number.
	• Fabric price group 7 each side	+\$304	Specify fabric color number.
	• Fabric price group COM each side	+\$ 23	Specify fabric color number.
		Fabric direction on 18"W to 60"W panels	
	• Vertical application, side 1	No cost	Specify with vertical application.
	• Vertical application, side 2	No cost	Specify with vertical application.
	Trim		
	• Paint price group 1	No cost	Specify paint color number.
	• Paint price group 2	+\$ 16	Specify paint color number.
	• Paint price group 3	+\$ 34	Specify paint color number.
	Top cap		
	• Omit top cap	No cost	Specify omit top cap.
	• Wood group 1 (18"W to 48"W)	+\$277	Specify with wood top cap and select wood color number.
	• Wood group 1 (60"W to 72"W)	+\$365	Specify with wood top cap and select wood color number.
	• Customiz stain on wood	No cost	Specify with Customiz stain.
	Change-of-Height Top Cap		
	• Change-of-height at one end of top cap	+\$ 7	Specify with change-of-height, one end.
	• Change-of-height at both ends of top cap	+\$ 7	Specify with change-of-height, both ends.
	Base Trim		
	• Knockouts one side, plain one side (24"W to 72"W only)	No cost	Specify with knockouts one side, plain one side.
	• Plain both sides (24"W to 72"W only)	No cost	Specify with plain both sides.
	• Open base	No cost	Specify with omit open base.
	Cable Tray		
	• Cable tray	No cost	Specify with cable tray.
	Base Cable Tray		
	• Base cable tray	+\$ 5	Specify with base cable tray.
	Power with 3+1, 2+2, or Three Separate Neutrals (3SN) Wiring Schematics		
	• One pass-through power harness 18"W to 48"W	+\$242	Specify with one pass-through harness and indicate wiring schematic type (3+1, 2+2, or 3SN).
	• One pass-through power harness 60"W to 72"W	+\$270	Specify with one pass-through harness and indicate wiring schematic type (3+1, 2+2, or 3SN).
	• One powerkit 24"W to 48"	+\$300	Specify with one powerkit and indicate wiring schematic type (3+1, 2+2, or 3SN).
	• One powerkit 60"W or 72"	+\$452	Specify with one powerkit and indicate wiring schematic type (3+1, 2+2, or 3SN).

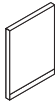
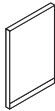
Specification Information

42"H			48"H			54"H			66"H		
											
Width	Style Number	U.S. Base Price	Style Number	U.S. Base Price	Style Number	U.S. Base Price	Style Number	U.S. Base Price			

Full Skin Tackable Acoustical Panel Packages

18"	TS74218TTF	\$ 568	TS74818TTF	\$ 580	TS75418TTF	\$ 597	TS76618TTF	\$ 701
24"	TS74224TTF	\$ 615	TS74824TTF	\$ 622	TS75424TTF	\$ 631	TS76624TTF	\$ 740
30"	TS74230TTF	\$ 654	TS74830TTF	\$ 661	TS75430TTF	\$ 677	TS76630TTF	\$ 782
36"	TS74236TTF	\$ 701	TS74836TTF	\$ 716	TS75436TTF	\$ 731	TS76636TTF	\$ 826
42"	TS74242TTF	\$ 777	TS74842TTF	\$ 785	TS75442TTF	\$ 800	TS76642TTF	\$ 900
48"	TS74248TTF	\$ 884	TS74848TTF	\$ 895	TS75448TTF	\$ 915	TS76648TTF	\$1015
60"	TS74260TTF	\$1043	TS74860TTF	\$1053	TS75460TTF	\$1075	TS76660TTF	\$1164
72"	TS74272TTF	\$1206	TS74872TTF	\$1218	TS75472TTF	\$1244	TS76672TTF	\$1328

Full Skin Performance Tackable Acoustical Panel Packages

18"	TS74218TPF	\$ 625	TS74818TPF	\$ 637	TS75418TPF	\$ 649	TS76618TPF	\$ 765
24"	TS74224TPF	\$ 668	TS74824TPF	\$ 682	TS75424TPF	\$ 701	TS76624TPF	\$ 801
30"	TS74230TPF	\$ 718	TS74830TPF	\$ 731	TS75430TPF	\$ 749	TS76630TPF	\$ 850
36"	TS74236TPF	\$ 767	TS74836TPF	\$ 782	TS75436TPF	\$ 794	TS76636TPF	\$ 897
42"	TS74242TPF	\$ 838	TS74842TPF	\$ 855	TS75442TPF	\$ 869	TS76642TPF	\$ 985
48"	TS74248TPF	\$ 964	TS74848TPF	\$ 982	TS75448TPF	\$1007	TS76648TPF	\$1116
60"	TS74260TPF	\$1129	TS74860TPF	\$1147	TS75460TPF	\$1174	TS76660TPF	\$1272
72"	TS74272TPF	\$1311	TS74872TPF	\$1328	TS75472TPF	\$1343	TS76672TPF	\$1448

Panels—Thin Trim



For Canadian Pricing
 Multiply U.S. Price by the Canadian price factor.
 ▶ See page 1 for details.

Answer Boundary Screens

Straight, Single-Connect For Use with Thin Trim Panels

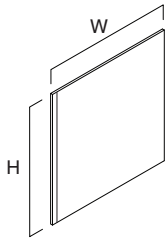

Tip: Additional hardware upcharge is applied only when single-connect straight split style number is specified.

Tip: When specifying a boundary screen equal to or taller than an Answer panel, order a same height end-of-run junction for height of Answer panel with the omit trim option.

Tip: When attaching boundary screen to Answer panel with stacking segment, order a boundary screen, end-of-run junction, omit trim, add a change-of-height trim, and stacking junction.

Tip: When specifying a boundary screen shorter than Answer panel, order a same height end-of-run junction for height of Answer panel with the omit trim option, and order a change-of-height trim.

Tip: When specifying the paint finish for the bracket cover, select a finish that compliments the selected laminate or veneer finish.

For laminate price group 2 and 3 pricing, please refer to the electronic catalog or SmartTools.

Tip: When specifying a split boundary screen, two screen widths will need to be specified.

Tip: Full-fill finish codes can be used to simplify specification of veneer boundary screens being used in settings with full-fill veneer products. The screen will not have the final fill coat applied, but the finish color will be consistent with the full-fill products.

Standard Includes		Required to Specify
<ul style="list-style-type: none"> ▶ Need help? Product details, page 80 • Screen: High-Pressure Laminate price group 1 or wood group 1 veneer • Edge on laminate screen, if selected: plastic • Height: 30"H–54"H • Width: <ul style="list-style-type: none"> – Single-sided: 27"W–75"W – Spanning : 51"W–75"W – Split left and right: 25½"W–73½"W • Connecting panel cover: paint price group 1 • 1½" adjustable glides • Attachment hardware 	<ol style="list-style-type: none"> 1 Style number 2 Screen size type (see below under Required Selections) 3 Screen height(s) 4 Height of connecting panel (see below under Required Selections) 5 Screen width(s) 6 Handedness: on single-sided screens, if selected (see below under Required Selections) 7 High-Pressure Laminate or wood veneer color for screen 8 Plastic color number for edge on laminate screen, if selected 9 Grain direction 10 Paint color number for connecting panel cover 11 Options, if selected (see below) 	
▶ See <i>Surface Materials</i> , page 668.		

Required Component	U.S. Price
Additional Hardware	
• Single-connect straight split	+\$ 29

Required Selections	U.S. Price	Required to Specify
Screen Size Type		
• Modular	No cost	Specify with modular.
• Parametric	No cost	Specify with parametric.
Height of Connecting Panel		
• 30"H	No cost	Specify with 30"H.
• 36"H	No cost	Specify with 36"H.
• 42"H	No cost	Specify with 42"H.
• 48"H	No cost	Specify with 48"H.
• 54"H	No cost	Specify with 54"H.
• 60"H	No cost	Specify with 60"H.
• 66"H	No cost	Specify with 66"H.
• 72"H	No cost	Specify with 72"H.
• 78"H	No cost	Specify with 78"H.
• 84"H	No cost	Specify with 84"H.
• 90"H	No cost	Specify with 90"H.
Handedness (Single-Sided Screens Only)		
• Right handed	No cost	Specify with single-sided right.
• Left handed	No cost	Specify with single-sided left.

Options	U.S. Price	Required to Specify
Surface Materials		
Screen		
• Laminate price group 2	See information at left	Specify laminate color number.
• Laminate price group 3	See information at left	Specify laminate color number.
• Open Line laminate	+\$201	▶ See <i>Surface Materials Reference Manual</i> .
	plus cost of laminate	
• Composite veneer group 1	Prices at right	Specify composite veneer color number.
• Composite veneer group 2	+\$201	Specify composite veneer color number.
• Wood group 2	+\$201	Specify wood color number.
• Wood group 3	+\$713	Specify wood color number.
• Customiz stain	No cost	Specify with <i>Customiz stain</i> .
• Full-fill finish on wood group 1	No cost	Specify full-fill finish number.
Connecting panel cover		
• Paint price group 2	+\$ 16	Specify paint color number.
• Paint price group 3	+\$ 34	Specify paint color number.

▶ Options, continued on next page

► Options, continued from previous page

Options	U.S. Price	Required to Specify
Surface Materials, continued	Laminate wood grain direction	
	• No direction	No cost Specify with <i>no direction</i> .
	• Horizontal	No cost Specify with <i>horizontal grain direction</i> .
	• Vertical	No cost Specify with <i>vertical grain direction</i> .
	Wood veneer grain direction	
	• No direction	No cost Specify with <i>no direction</i> .
	• Horizontal	No cost Specify with <i>horizontal grain direction</i> .
	• Vertical	No cost Specify with <i>vertical grain direction</i> .

Specification Information

Style Number	Dimensions H	Screen Type	U.S. Base Prices								
			Modular Width	27"W	33"W	39"W	45"W	51"W	57"W	63"W	69" W
		Parametric Width	27"W – 32 ¹⁵ / ₁₆ "W	33"W – 38 ¹⁵ / ₁₆ "W	39"W – 44 ¹⁵ / ₁₆ "W	45"W – 50 ¹⁵ / ₁₆ "W	51"W – 56 ¹⁵ / ₁₆ "W	57"W – 62 ¹⁵ / ₁₆ "W	63"W – 68 ¹⁵ / ₁₆ "W	69"W – 74 ¹⁵ / ₁₆ "W	75"W

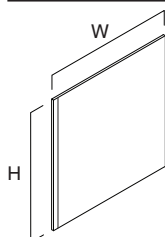

Straight Single-Connect Boundary Screen—Single-Sided

High-Pressure Laminate

TS7SCSSD	Height	27"W	33"W	39"W	45"W	51"W	57"W	63"W	69" W	75"W
	30"H	\$ 734	\$ 875	\$1020	\$1162	\$1307	\$1450	\$1595	\$1737	\$1881
	36"H	\$ 746	\$ 906	\$1065	\$1221	\$1379	\$1537	\$1696	\$1852	\$2010
	42"H	\$ 762	\$ 934	\$1105	\$1276	\$1450	\$1622	\$1793	\$1967	\$2141
	48"H	\$ 776	\$ 962	\$1150	\$1335	\$1522	\$1709	\$1896	\$2081	\$2270
	54"H	\$ 791	\$ 991	\$1191	\$1393	\$1595	\$1793	\$1996	\$2199	\$2398

Composite Veneer

TS7SCSSD	Height	27"W	33"W	39"W	45"W	51"W	57"W	63"W	69" W	75"W
	30"H	\$ 992	\$1249	\$1509	\$1765	\$2025	\$2283	\$2543	\$2802	\$3060
	36"H	\$1077	\$1358	\$1639	\$1919	\$2197	\$2477	\$2761	\$3037	\$3317
	42"H	\$1163	\$1465	\$1766	\$2067	\$2368	\$2669	\$2972	\$3274	\$3578
	48"H	\$1250	\$1572	\$1896	\$2218	\$2542	\$2865	\$3189	\$3510	\$3835
	54"H	\$1338	\$1680	\$2024	\$2370	\$2717	\$3057	\$3404	\$3749	\$4094

Wood Veneer

TS7SCSSD	Height	27"W	33"W	39"W	45"W	51"W	57"W	63"W	69" W	75"W
	30"H	\$ 992	\$1249	\$1509	\$1765	\$2025	\$2283	\$2543	\$2802	\$3060
	36"H	\$1077	\$1358	\$1639	\$1919	\$2197	\$2477	\$2761	\$3037	\$3317
	42"H	\$1163	\$1465	\$1766	\$2067	\$2368	\$2669	\$2972	\$3274	\$3578
	48"H	\$1250	\$1572	\$1896	\$2218	\$2542	\$2865	\$3189	\$3510	\$3835
	54"H	\$1338	\$1680	\$2024	\$2370	\$2717	\$3057	\$3404	\$3749	\$4094

► Specification Information, continued on next page

Answer Boundary Screens Straight, Single-Connect For Use with Thin Trim Panels, continued

► Specification Information, continued from previous page

Specification Information

Style Number	Dimensions H	Screen Type	U.S. Base Prices								
			Modular Width	27"W	33"W	39"W	45"W	51"W	57"W	63"W	69"W
		Parametric Width	27"W – 32 ¹⁵ / ₁₆ "W	33"W – 38 ¹⁵ / ₁₆ "W	39"W – 44 ¹⁵ / ₁₆ "W	45"W – 50 ¹⁵ / ₁₆ "W	51"W – 56 ¹⁵ / ₁₆ "W	57"W – 62 ¹⁵ / ₁₆ "W	63"W – 68 ¹⁵ / ₁₆ "W	69"W – 74 ¹⁵ / ₁₆ "W	75"W

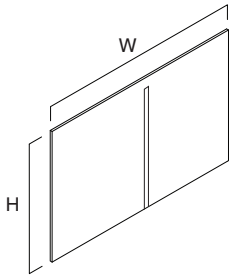

Straight Single-Connect Boundary Screen—Spanning

High-Pressure Laminate

Style Number	Dimensions H	27"W	33"W	39"W	45"W	51"W	57"W	63"W	69"W	75"W
TS7SCSPN	30"H	N.A.	N.A.	N.A.	N.A.	\$1307	\$1450	\$1595	\$1737	\$1881
	36"H	N.A.	N.A.	N.A.	N.A.	\$1379	\$1537	\$1696	\$1852	\$2010
	42"H	N.A.	N.A.	N.A.	N.A.	\$1450	\$1622	\$1793	\$1967	\$2141
	48"H	N.A.	N.A.	N.A.	N.A.	\$1522	\$1709	\$1896	\$2081	\$2270
	54"H	N.A.	N.A.	N.A.	N.A.	\$1595	\$1793	\$1996	\$2199	\$2398

Composite Veneer

Style Number	Dimensions H	27"W	33"W	39"W	45"W	51"W	57"W	63"W	69"W	75"W
TS7SCSPN	30"H	N.A.	N.A.	N.A.	N.A.	\$2025	\$2283	\$2543	\$2802	\$3060
	36"H	N.A.	N.A.	N.A.	N.A.	\$2197	\$2477	\$2761	\$3037	\$3317
	42"H	N.A.	N.A.	N.A.	N.A.	\$2368	\$2669	\$2972	\$3274	\$3578
	48"H	N.A.	N.A.	N.A.	N.A.	\$2542	\$2865	\$3189	\$3510	\$3835
	54"H	N.A.	N.A.	N.A.	N.A.	\$2717	\$3057	\$3404	\$3749	\$4094

Wood Veneer

Style Number	Dimensions H	27"W	33"W	39"W	45"W	51"W	57"W	63"W	69"W	75"W
TS7SCSPN	30"H	N.A.	N.A.	N.A.	N.A.	\$2025	\$2283	\$2543	\$2802	\$3060
	36"H	N.A.	N.A.	N.A.	N.A.	\$2197	\$2477	\$2761	\$3037	\$3317
	42"H	N.A.	N.A.	N.A.	N.A.	\$2368	\$2669	\$2972	\$3274	\$3578
	48"H	N.A.	N.A.	N.A.	N.A.	\$2542	\$2865	\$3189	\$3510	\$3835
	54"H	N.A.	N.A.	N.A.	N.A.	\$2717	\$3057	\$3404	\$3749	\$4094

► Specification Information, continued on next page



For Canadian Pricing

Multiply U.S. Price by the Canadian price factor.

► See page 1 for details.

► Specification Information, continued from previous page

Specification Information											
Style Number	Dimensions H	Screen Type	U.S. Base Prices								
			Modular Width	25½"W	31½"W	37½"W	43½"W	49½"W	55½"W	61½"W	67½"W
Parametric Width	25½"W – 31½"W – 37½"W – 43½"W – 49½"W – 55½"W – 61½"W – 67½"W – 73½"W	31⅞"W	37⅞"W	43⅞"W	49⅞"W	55⅞"W	61⅞"W	67⅞"W	73⅞"W		

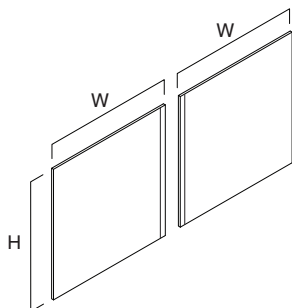

Straight Single-Connect Boundary Screens—Split

High-Pressure Laminate

Style Number	Dimensions H	25½"W	31½"W	37½"W	43½"W	49½"W	55½"W	61½"W	67½"W	73½"W
TS7SCSPT	30"H	\$ 734	\$ 875	\$1020	\$1162	\$1307	\$1450	\$1595	\$1737	\$1881
	36"H	\$ 746	\$ 906	\$1065	\$1221	\$1379	\$1537	\$1696	\$1852	\$2010
	42"H	\$ 762	\$ 934	\$1105	\$1276	\$1450	\$1622	\$1793	\$1967	\$2141
	48"H	\$ 776	\$ 962	\$1150	\$1335	\$1522	\$1709	\$1896	\$2081	\$2270
	54"H	\$ 791	\$ 991	\$1191	\$1393	\$1595	\$1793	\$1996	\$2199	\$2398

Composite Veneer

Style Number	Dimensions H	25½"W	31½"W	37½"W	43½"W	49½"W	55½"W	61½"W	67½"W	73½"W
TS7SCSPT	30"H	\$ 992	\$1249	\$1509	\$1765	\$2025	\$2283	\$2543	\$2802	\$3060
	36"H	\$1077	\$1358	\$1639	\$1919	\$2197	\$2477	\$2761	\$3037	\$3317
	42"H	\$1163	\$1465	\$1766	\$2067	\$2368	\$2669	\$2972	\$3274	\$3578
	48"H	\$1250	\$1572	\$1896	\$2218	\$2542	\$2865	\$3189	\$3510	\$3835
	54"H	\$1338	\$1680	\$2024	\$2370	\$2717	\$3057	\$3404	\$3749	\$4094

Wood Veneer

Style Number	Dimensions H	25½"W	31½"W	37½"W	43½"W	49½"W	55½"W	61½"W	67½"W	73½"W
TS7SCSPT	30"H	\$ 992	\$1249	\$1509	\$1765	\$2025	\$2283	\$2543	\$2802	\$3060
	36"H	\$1077	\$1358	\$1639	\$1919	\$2197	\$2477	\$2761	\$3037	\$3317
	42"H	\$1163	\$1465	\$1766	\$2067	\$2368	\$2669	\$2972	\$3274	\$3578
	48"H	\$1250	\$1572	\$1896	\$2218	\$2542	\$2865	\$3189	\$3510	\$3835
	54"H	\$1338	\$1680	\$2024	\$2370	\$2717	\$3057	\$3404	\$3749	\$4094

Tip: When specifying a split boundary screen, two screen widths need to be specified. The final price will include the price of both individual screen segments.

 **For Canadian Pricing**
 Multiply U.S. Price by the Canadian price factor.
 ► See page 1 for details.

Answer Boundary Screens

Straight, Dual-Connect For Use with Thin Trim Panels

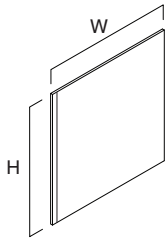

Tip: Additional hardware upcharge is applied only when single-connect straight split style number is specified.

Tip: When specifying a boundary screen equal to or taller than an Answer panel, order a same height end-of-run junction for height of Answer panel with the omit trim option.

Tip: When attaching boundary screen to Answer panel with stacking segment, order a boundary screen, end-of-run junction, omit trim, add a change-of-height trim, and stacking junction.

Tip: When specifying a boundary screen shorter than Answer panel, order a same height end-of-run junction for height of Answer panel with the omit trim option, and order a change-of-height trim.

Tip: When specifying the paint finish for the bracket cover, select a finish that complements the selected laminate or veneer finish.

For laminate price group 2 and 3 pricing, please refer to the electronic catalog or SmartTools.

Tip: When specifying a split boundary screen, two screen widths will need to be specified.

Tip: Full-fill finish codes can be used to simplify specification of veneer boundary screens being used in settings with full-fill veneer products. The screen will not have the final fill coat applied, but the finish color will be consistent with the full-fill products.

Standard Includes		Required to Specify
▶ Need help? Product details, page 80	<ul style="list-style-type: none"> Screen: High-Pressure Laminate price group 1 or wood group 1 veneer Edge on laminate screen: plastic, if selected Height: 30"H–54"H Width: <ul style="list-style-type: none"> – Single-sided: 27"W–75"W – Spanning : 51"W–75"W – Split left and right: 25½"W–73½"W Connecting panel cover: paint price group 1 1½" adjustable glides Attachment hardware 	<ol style="list-style-type: none"> Style number Screen size type (see below under Required Selections) Screen height(s) Height of connecting panel (see below under Required Selections) Screen width(s) Handedness: on single-sided screens, if selected (see below under Required Selections) High-Pressure Laminate or wood veneer color for screen Plastic color number for edge on laminate screen, if selected Grain direction Paint color number for connecting panel cover Options, if selected (see below) <p>▶ See <i>Surface Materials</i>, page 668.</p>

Required Component	U.S. Price
--------------------	------------

Additional Hardware	<ul style="list-style-type: none"> Dual-connect straight split +\$ 29
----------------------------	--------------------------------------------------------------------------------------

Required Selections	U.S. Price	Required to Specify
---------------------	------------	---------------------

Screen Size Type	<ul style="list-style-type: none"> Modular No cost Parametric No cost 	Specify with modular. Specify with parametric.
Height of Connecting Panel	<ul style="list-style-type: none"> 30"H No cost 36"H No cost 42"H No cost 48"H No cost 54"H No cost 60"H No cost 66"H No cost 72"H No cost 78"H No cost 84"H No cost 90"H No cost 	Specify with 30"H. Specify with 36"H. Specify with 42"H. Specify with 48"H. Specify with 54"H. Specify with 60"H. Specify with 66"H. Specify with 72"H. Specify with 78"H. Specify with 84"H. Specify with 90"H.
Handedness (Single-Sided Screens Only)	<ul style="list-style-type: none"> Right handed No cost Left handed No cost 	Specify with single-sided right. Specify with single-sided left.

Options	U.S. Price	Required to Specify
---------	------------	---------------------

Surface Materials	<p>Screen</p> <ul style="list-style-type: none"> Laminate price group 2 See information at left Laminate price group 3 See information at left Open Line laminate +\$201 <p>plus cost of laminate</p> <ul style="list-style-type: none"> Composite veneer group 1 Prices at right Composite veneer group 2 +\$201 Wood group 2 +\$201 Wood group 3 +\$713 Customiz stain No cost Full-fill finish on wood group 1 No cost 	<p>Specify laminate color number. Specify laminate color number. ▶ See <i>Surface Materials Reference Manual</i>.</p> <p>Specify composite veneer color number. Specify composite veneer color number. Specify wood color number. Specify wood color number. Specify with Customiz stain. Specify full-fill finish number.</p>
	<p>Connecting panel cover</p> <ul style="list-style-type: none"> Paint price group 2 +\$ 16 Paint price group 3 +\$ 34 	Specify paint color number. Specify paint color number.
	<p>Laminate wood grain direction</p> <ul style="list-style-type: none"> No direction No cost Horizontal No cost Vertical No cost 	Specify with no direction. Specify with horizontal grain direction. Specify with vertical grain direction.

▶ Options, continued on next page

► Options, continued from previous page

Options	U.S. Price	Required to Specify
Surface Materials, continued		
Wood veneer grain direction		
• No direction	No cost	Specify with <i>no direction</i> .
• Horizontal	No cost	Specify with <i>horizontal grain direction</i> .
• Vertical	No cost	Specify with <i>vertical grain direction</i> .

Specification Information

Style Number	Dimensions H	Screen Type	U.S. Base Prices								
			Modular Width	27"W	33"W	39"W	45"W	51"W	57"W	63"W	69" W
		Parametric Width	27"W – 32 ¹ / ₁₆ "W	33"W – 38 ¹ / ₁₆ "W	39"W – 44 ¹ / ₁₆ "W	45"W – 50 ¹ / ₁₆ "W	51"W – 56 ¹ / ₁₆ "W	57"W – 62 ¹ / ₁₆ "W	63"W – 68 ¹ / ₁₆ "W	69"W – 74 ¹ / ₁₆ "W	75"W

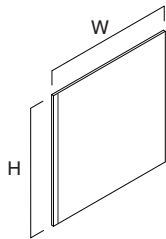

Straight Dual-Connect Boundary Screen—Single-Sided

High-Pressure Laminate

TS7DCSSD	30"H	\$ 431	\$ 518	\$ 603	\$ 689	\$ 776	\$ 861	\$ 948	\$1036	\$1122
	36"H	\$ 446	\$ 538	\$ 631	\$ 726	\$ 818	\$ 912	\$1007	\$1099	\$1191
	42"H	\$ 460	\$ 560	\$ 661	\$ 762	\$ 861	\$ 962	\$1065	\$1162	\$1264
	48"H	\$ 474	\$ 582	\$ 689	\$ 797	\$ 906	\$1014	\$1122	\$1227	\$1335
	54"H	\$ 489	\$ 603	\$ 718	\$ 833	\$ 948	\$1065	\$1179	\$1293	\$1408

Composite Veneer

TS7DCSSD	30"H	\$ 790	\$1007	\$1221	\$1435	\$1651	\$1868	\$2082	\$2300	\$2515
	36"H	\$ 906	\$1134	\$1365	\$1596	\$1825	\$2055	\$2283	\$2513	\$2741
	42"H	\$1020	\$1264	\$1508	\$1753	\$1995	\$2238	\$2487	\$2727	\$2973
	48"H	\$1135	\$1394	\$1651	\$1909	\$2170	\$2428	\$2687	\$2943	\$3202
	54"H	\$1251	\$1521	\$1795	\$2069	\$2341	\$2615	\$2888	\$3160	\$3432

Wood Veneer

TS7DCSSD	30"H	\$ 790	\$1007	\$1221	\$1435	\$1651	\$1868	\$2082	\$2300	\$2515
	36"H	\$ 906	\$1134	\$1365	\$1596	\$1825	\$2055	\$2283	\$2513	\$2741
	42"H	\$1020	\$1264	\$1508	\$1753	\$1995	\$2238	\$2487	\$2727	\$2973
	48"H	\$1135	\$1394	\$1651	\$1909	\$2170	\$2428	\$2687	\$2943	\$3202
	54"H	\$1251	\$1521	\$1795	\$2069	\$2341	\$2615	\$2888	\$3160	\$3432

► Specification Information, continued on next page



For Canadian Pricing

Multiply U.S. Price by the Canadian price factor.

► See page 1 for details.

Answer Boundary Screens Straight, Dual-Connect For Use with Thin Trim Panels, continued

► Specification Information, continued from previous page

Specification Information											
Style Number	Dimensions H	Screen Type	U.S. Base Prices								
			Modular Width	27"W	33"W	39"W	45"W	51"W	57"W	63"W	69"W
		Parametric Width	27"W – 32 ¹⁵ / ₁₆ "W	33"W – 38 ¹⁵ / ₁₆ "W	39"W – 44 ¹⁵ / ₁₆ "W	45"W – 50 ¹⁵ / ₁₆ "W	51"W – 56 ¹⁵ / ₁₆ "W	57"W – 62 ¹⁵ / ₁₆ "W	63"W – 68 ¹⁵ / ₁₆ "W	69"W – 74 ¹⁵ / ₁₆ "W	75"W

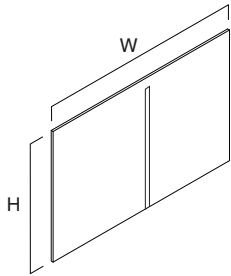

Straight Dual-Connect Boundary Screen—Spanning

High-Pressure Laminate

Style Number	Dimensions H	27"W	33"W	39"W	45"W	51"W	57"W	63"W	69"W	75"W
TS7DCSPN	30"H	N.A.	N.A.	N.A.	N.A.	\$ 776	\$ 861	\$ 948	\$1036	\$1122
	36"H	N.A.	N.A.	N.A.	N.A.	\$ 818	\$ 912	\$1007	\$1099	\$1191
	42"H	N.A.	N.A.	N.A.	N.A.	\$ 861	\$ 962	\$1065	\$1162	\$1264
	48"H	N.A.	N.A.	N.A.	N.A.	\$ 906	\$1014	\$1122	\$1227	\$1335
	54"H	N.A.	N.A.	N.A.	N.A.	\$ 948	\$1065	\$1179	\$1293	\$1408

Composite Veneer

Style Number	Dimensions H	27"W	33"W	39"W	45"W	51"W	57"W	63"W	69"W	75"W
TS7DCSPN	30"H	N.A.	N.A.	N.A.	N.A.	\$1651	\$1868	\$2082	\$2300	\$2515
	36"H	N.A.	N.A.	N.A.	N.A.	\$1825	\$2055	\$2283	\$2513	\$2741
	42"H	N.A.	N.A.	N.A.	N.A.	\$1995	\$2238	\$2487	\$2727	\$2973
	48"H	N.A.	N.A.	N.A.	N.A.	\$2170	\$2428	\$2687	\$2943	\$3202
	54"H	N.A.	N.A.	N.A.	N.A.	\$2341	\$2615	\$2888	\$3160	\$3432

Wood Veneer

Style Number	Dimensions H	27"W	33"W	39"W	45"W	51"W	57"W	63"W	69"W	75"W
TS7DCSPN	30"H	N.A.	N.A.	N.A.	N.A.	\$1651	\$1868	\$2082	\$2300	\$2515
	36"H	N.A.	N.A.	N.A.	N.A.	\$1825	\$2055	\$2283	\$2513	\$2741
	42"H	N.A.	N.A.	N.A.	N.A.	\$1995	\$2238	\$2487	\$2727	\$2973
	48"H	N.A.	N.A.	N.A.	N.A.	\$2170	\$2428	\$2687	\$2943	\$3202
	54"H	N.A.	N.A.	N.A.	N.A.	\$2341	\$2615	\$2888	\$3160	\$3432

Tip: When specifying a boundary screen shorter than Answer panel, order a boundary screen, end-of-run junction for height of Answer panel, omit trim, and add a change-of-height trim.

► Specification Information, continued on next page



For Canadian Pricing

Multiply U.S. Price by the Canadian price factor.

► See page 1 for details.

► Specification Information, continued from previous page

Specification Information											
Style Number	Dimensions H	Screen Type	U.S. Base Prices								
			Modular Width	25½"W	31½"W	37½"W	43½"W	49½"W	55½"W	61½"W	67½"W
Parametric Width	25½"W – 31⅞"W	31½"W – 37⅞"W	37½"W – 43⅞"W	43½"W – 49⅞"W	49½"W – 55⅞"W	55½"W – 61⅞"W	61½"W – 67⅞"W	67½"W – 73⅞"W	73½"W		

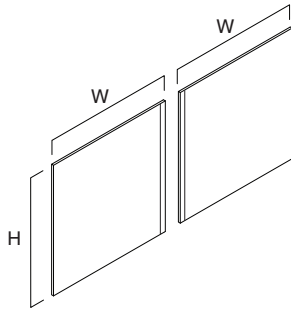

Straight Dual-Connect Boundary Screens—Split

High-Pressure Laminate

Style Number	Dimensions H	25½"W	31½"W	37½"W	43½"W	49½"W	55½"W	61½"W	67½"W	73½"W
TS7DCSPT	30"H	\$ 431	\$ 518	\$ 603	\$ 689	\$ 776	\$ 861	\$ 948	\$1036	\$1122
	36"H	\$ 446	\$ 538	\$ 631	\$ 726	\$ 818	\$ 912	\$1007	\$1099	\$1191
	42"H	\$ 460	\$ 560	\$ 661	\$ 762	\$ 861	\$ 962	\$1065	\$1162	\$1264
	48"H	\$ 474	\$ 582	\$ 689	\$ 797	\$ 906	\$1014	\$1122	\$1227	\$1335
	54"H	\$ 489	\$ 603	\$ 718	\$ 833	\$ 948	\$1065	\$1179	\$1293	\$1408

Composite Veneer

Style Number	Dimensions H	25½"W	31½"W	37½"W	43½"W	49½"W	55½"W	61½"W	67½"W	73½"W
TS7DCSPT	30"H	\$ 790	\$1007	\$1221	\$1435	\$1651	\$1868	\$2082	\$2300	\$2515
	36"H	\$ 906	\$1134	\$1365	\$1596	\$1825	\$2055	\$2283	\$2513	\$2741
	42"H	\$1020	\$1264	\$1508	\$1753	\$1995	\$2238	\$2487	\$2727	\$2973
	48"H	\$1135	\$1394	\$1651	\$1909	\$2170	\$2428	\$2687	\$2943	\$3202
	54"H	\$1251	\$1521	\$1795	\$2069	\$2341	\$2615	\$2888	\$3160	\$3432

Wood Veneer

Style Number	Dimensions H	25½"W	31½"W	37½"W	43½"W	49½"W	55½"W	61½"W	67½"W	73½"W
TS7DCSPT	30"H	\$ 790	\$1007	\$1221	\$1435	\$1651	\$1868	\$2082	\$2300	\$2515
	36"H	\$ 906	\$1134	\$1365	\$1596	\$1825	\$2055	\$2283	\$2513	\$2741
	42"H	\$1020	\$1264	\$1508	\$1753	\$1995	\$2238	\$2487	\$2727	\$2973
	48"H	\$1135	\$1394	\$1651	\$1909	\$2170	\$2428	\$2687	\$2943	\$3202
	54"H	\$1251	\$1521	\$1795	\$2069	\$2341	\$2615	\$2888	\$3160	\$3432

Tip: When specifying a split boundary screen, two screen widths need to be specified. The final price will include the price of both individual screen segments.

 **For Canadian Pricing**
 Multiply U.S. Price by the Canadian price factor.
 ► See page 1 for details.

Answer Boundary Screens

L Return, Single-Connect For Use with Thin Trim Panels

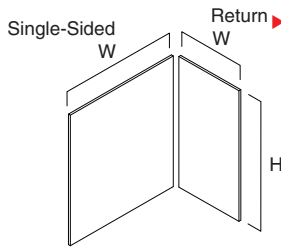

Tip: Additional hardware upcharges are applied only when single-connect single-sided L return, or single-connect split L style numbers are specified.

Tip: When specifying a boundary screen equal to or taller than an Answer panel, order a same height end-of-run junction for height of Answer panel with the omit trim option.

Tip: When attaching boundary screen to Answer panel with stacking segment, order a boundary screen, end-of-run junction, omit trim, add a change-of-height trim, and stacking junction.

Tip: When specifying a boundary screen shorter than Answer panel, order a same height end-of-run junction for height of Answer panel with the omit trim option, and order a change-of-height trim.

Tip: When specifying the paint finish for the bracket cover, select a finish that compliments the selected laminate or veneer finish.

For laminate price group 2 and 3 pricing, please refer to the electronic catalog or SmartTools.

Tip: When specifying a split L return boundary screen, four screen widths will need to be specified.

Tip: Full-fill finish codes can be used to simplify specification of veneer boundary screens being used in settings with full-fill veneer products. The screen will not have the final fill coat applied, but the finish color will be consistent with the full-fill products.

Standard Includes	Required to Specify
-------------------	---------------------

<p>▶ Need help? Product details, page 80</p> <ul style="list-style-type: none"> • Primary and return screen: High-Pressure Laminate price group 1 or wood group 1 veneer • Edge on laminate screen: plastic, if selected • Height: 30"H–54"H • Width: <ul style="list-style-type: none"> – Single-sided: 27"W–75"W – Split left and right: 25½"W–73½"W • Connecting panel cover: paint price group 1 • 1½" adjustable glides • Attachment hardware 	<ol style="list-style-type: none"> 1 Style number 2 Screen size type (see below under Required Selections) 3 Screen height(s) 4 Height of connecting panel (see below under Required Selections) 5 Screen width(s) 6 Handedness: on single-sided screens, if selected (see below under Required Selections) 7 High-Pressure Laminate or wood veneer color for screen 8 Plastic color number for edge on laminate screen, if selected 9 Grain direction 10 Paint color number for connecting panel cover 11 Options, if selected (see below) <p>▶ See <i>Surface Materials</i>, page 668.</p>
------------------------------------------------------------------------------------------------------------------------------------------------------------------------------------------------------------------------------------------------------------------------------------------------------------------------------------------------------------------------------------------------------------------------------------------------------------------------------------------------------------------------------------------------------------------------------	-------------------------------------------------------------------------------------------------------------------------------------------------------------------------------------------------------------------------------------------------------------------------------------------------------------------------------------------------------------------------------------------------------------------------------------------------------------------------------------------------------------------------------------------------------------------------------------------------------------------------------------------------------------------------------------------------------

Required Component	U.S. Price
--------------------	------------

Additional Hardware	<ul style="list-style-type: none"> • Single-connect single-sided L return +\$ 58 • Single-connect split L return +\$ 86
----------------------------	-------------------------------------------------------------------------------------------------------------------------------------------------

Required Selections	U.S. Price	Required to Specify
---------------------	------------	---------------------

Screen Size Type	<ul style="list-style-type: none"> • Modular No cost • Parametric No cost 	Specify with <i>modular</i> . Specify with <i>parametric</i> .
Height of Connecting Panel	<ul style="list-style-type: none"> • 30"H No cost • 36"H No cost • 42"H No cost • 48"H No cost • 54"H No cost • 60"H No cost • 66"H No cost • 72"H No cost • 78"H No cost • 84"H No cost • 90"H No cost 	Specify with <i>30"H</i> . Specify with <i>36"H</i> . Specify with <i>42"H</i> . Specify with <i>48"H</i> . Specify with <i>54"H</i> . Specify with <i>60"H</i> . Specify with <i>66"H</i> . Specify with <i>72"H</i> . Specify with <i>78"H</i> . Specify with <i>84"H</i> . Specify with <i>90"H</i> .
Handedness (Single-Sided Screens Only)	<ul style="list-style-type: none"> • Right handed No cost • Left handed No cost 	Specify with <i>single-sided right</i> . Specify with <i>single-sided left</i> .

Options	U.S. Price	Required to Specify
---------	------------	---------------------

Surface Materials	<p>Screen</p> <ul style="list-style-type: none"> • Laminate price group 2 See information at left • Laminate price group 3 See information at left • Open Line laminate +\$201 <p>plus cost of laminate</p> <ul style="list-style-type: none"> • Composite veneer group 1 Prices at right • Composite veneer group 2 +\$201 • Wood group 2 +\$201 • Wood group 3 +\$713 • Customiz stain No cost • Full-fill finish on wood group 1 No cost 	<p>Specify laminate color number. Specify laminate color number. ▶ See <i>Surface Materials Reference Manual</i>.</p> <p>Specify composite veneer color number. Specify composite veneer color number. Specify wood color number. Specify wood color number. Specify with <i>Customiz stain</i>. Specify full-fill finish number.</p>
--------------------------	-------------------------------------------------------------------------------------------------------------------------------------------------------------------------------------------------------------------------------------------------------------------------------------------------------------------------------------------------------------------------------------------------------------------------------------------------------------------------------------------------------------------------------------------------	-------------------------------------------------------------------------------------------------------------------------------------------------------------------------------------------------------------------------------------------------------------------------------------------------------------------------------------------------------------------

Connecting panel cover	<ul style="list-style-type: none"> • Paint price group 2 +\$ 16 • Paint price group 3 +\$ 34 	Specify paint color number. Specify paint color number.
-------------------------------	----------------------------------------------------------------------------------------------------------------------	------------------------------------------------------------

Laminate wood grain direction	<ul style="list-style-type: none"> • No direction No cost • Horizontal No cost • Vertical No cost 	Specify with <i>no direction</i> . Specify with <i>horizontal grain direction</i> . Specify with <i>vertical grain direction</i> .
--------------------------------------	------------------------------------------------------------------------------------------------------------------------------------	------------------------------------------------------------------------------------------------------------------------------------------

▶ Options, continued on next page

► Options, continued from previous page

Options	U.S. Price	Required to Specify
Surface Materials, continued		
Wood veneer grain direction		
• No direction	No cost	Specify with <i>no direction</i> .
• Horizontal	No cost	Specify with <i>horizontal grain direction</i> .
• Vertical	No cost	Specify with <i>vertical grain direction</i> .

Specification Information

Style Number	Dimensions H	Screen Type	U.S. Base Prices								
			Modular Width	27"W	33"W	39"W	45"W	51"W	57"W	63"W	69" W
		Parametric Width	27"W – 32 ¹ / ₁₆ "W	33"W – 38 ¹ / ₁₆ "W	39"W – 44 ¹ / ₁₆ "W	45"W – 50 ¹ / ₁₆ "W	51"W – 56 ¹ / ₁₆ "W	57"W – 62 ¹ / ₁₆ "W	63"W – 68 ¹ / ₁₆ "W	69"W – 74 ¹ / ₁₆ "W	75"W

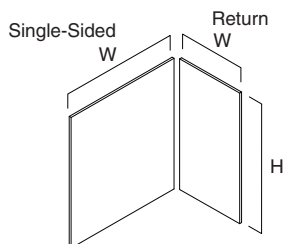

L Return Single-Connect Boundary Screens—Single-Sided

High-Pressure Laminate — Primary Screen

TS7SCLSSD	30"H	\$734	\$875	\$1020	\$1162	\$1307	\$1450	\$1595	\$1737	\$1881
	36"H	\$746	\$906	\$1065	\$1221	\$1379	\$1537	\$1696	\$1852	\$2010
	42"H	\$762	\$934	\$1105	\$1276	\$1450	\$1622	\$1793	\$1967	\$2141
	48"H	\$776	\$962	\$1150	\$1335	\$1522	\$1709	\$1896	\$2081	\$2270
	54"H	\$791	\$991	\$1191	\$1393	\$1595	\$1793	\$1996	\$2199	\$2398

Style Number	Dimensions H	Screen Type	U.S. Base Prices		
			Modular Width	18"W	24"W
		Parametric Width	18"W – 23 ¹ / ₁₆ "W	24"W – 29 ¹ / ₁₆ "W	30"W

High-Pressure Laminate — Return Screen

TS7SCLSSD	30"H	+\$661	+\$734	+\$875
	36"H	+\$668	+\$746	+\$906
	42"H	+\$676	+\$762	+\$934
	48"H	+\$682	+\$776	+\$962
	54"H	+\$689	+\$791	+\$991

Tip: When specifying an L return boundary screen, primary and return screen widths need to be specified. The final price will include the price of both individual screen segments.

► Specification Information, continued on next page



For Canadian Pricing

Multiply U.S. Price by the Canadian price factor.

► See page 1 for details.

Answer Boundary Screens L Return, Single-Connect For Use with Thin Trim Panels, continued

► Specification Information, continued from previous page

Specification Information											
Style Number	Dimensions H	Screen Type	U.S. Base Prices								
			Modular Width	27"W	33"W	39"W	45"W	51"W	57"W	63"W	69"W
		Parametric Width	27"W – 32 ¹⁵ / ₁₆ "W	33"W – 38 ¹⁵ / ₁₆ "W	39"W – 44 ¹⁵ / ₁₆ "W	45"W – 50 ¹⁵ / ₁₆ "W	51"W – 56 ¹⁵ / ₁₆ "W	57"W – 62 ¹⁵ / ₁₆ "W	63"W – 68 ¹⁵ / ₁₆ "W	69"W – 74 ¹⁵ / ₁₆ "W	75"W

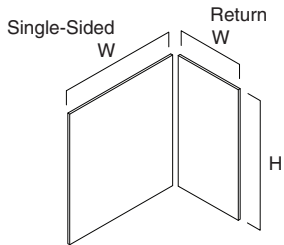

L Return Single-Connect Boundary Screens—Single Sided

Composite Veneer — Primary Screen

Style Number	Dimensions H	Screen Type	U.S. Base Prices								
		Modular Width	18"W	24"W	30"W						
		Parametric Width	18"W – 23 ¹⁵ / ₁₆ "W	24"W – 29 ¹⁵ / ₁₆ "W	30"W						
TS7SCLSSD	30"H		\$ 992	\$1249	\$1509	\$1765	\$2025	\$2283	\$2543	\$2802	\$3060
	36"H		\$1077	\$1358	\$1639	\$1919	\$2197	\$2477	\$2761	\$3037	\$3317
	42"H		\$1163	\$1465	\$1766	\$2067	\$2368	\$2669	\$2972	\$3274	\$3578
	48"H		\$1250	\$1572	\$1896	\$2218	\$2542	\$2865	\$3189	\$3510	\$3835
	54"H		\$1338	\$1680	\$2024	\$2370	\$2717	\$3057	\$3404	\$3749	\$4094

Style Number	Dimensions H	Screen Type	U.S. Base Prices		
			Modular Width	Parametric Width	30"W
		Modular Width	18"W	24"W	30"W
		Parametric Width	18"W – 23 ¹⁵ / ₁₆ "W	24"W – 29 ¹⁵ / ₁₆ "W	30"W

Composite Veneer — Return Screen

Style Number	Dimensions H	Screen Type	U.S. Base Prices		
TS7SCLSSD	30"H		+\$ 863	+\$ 992	+\$1249
	36"H		+\$ 939	+\$1077	+\$1358
	42"H		+\$1014	+\$1163	+\$1465
	48"H		+\$1090	+\$1250	+\$1572
	54"H		+\$1163	+\$1338	+\$1680

Tip: When specifying an L return boundary screen, primary and return screen widths need to be specified. The final price will include the price of both individual screen segments.

► Specification Information, continued on next page



For Canadian Pricing

Multiply U.S. Price by the Canadian price factor.

► See page 1 for details.

► Specification Information, continued from previous page

Specification Information											
Style Number	Dimensions H	Screen Type	U.S. Base Prices								
			Modular Width	27"W	33"W	39"W	45"W	51"W	57"W	63"W	69"W
		Parametric Width	27"W – 32 ¹⁵ / ₁₆ "W	33"W – 38 ¹⁵ / ₁₆ "W	39"W – 44 ¹⁵ / ₁₆ "W	45"W – 50 ¹⁵ / ₁₆ "W	51"W – 56 ¹⁵ / ₁₆ "W	57"W – 62 ¹⁵ / ₁₆ "W	63"W – 68 ¹⁵ / ₁₆ "W	69"W – 74 ¹⁵ / ₁₆ "W	75"W

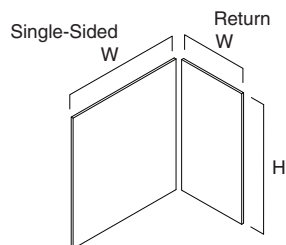

L Return Single-Connect Boundary Screens—Single Sided

Wood Veneer — Primary Screen

TS7SCLSSD	30"H	\$ 992	\$1249	\$1509	\$1765	\$2025	\$2283	\$2543	\$2802	\$3060
	36"H	\$1077	\$1358	\$1639	\$1919	\$2197	\$2477	\$2761	\$3037	\$3317
	42"H	\$1163	\$1465	\$1766	\$2067	\$2368	\$2669	\$2972	\$3274	\$3578
	48"H	\$1250	\$1572	\$1896	\$2218	\$2542	\$2865	\$3189	\$3510	\$3835
	54"H	\$1338	\$1680	\$2024	\$2370	\$2717	\$3057	\$3404	\$3749	\$4094

Style Number	Dimensions H	Screen Type	U.S. Base Prices		
			Modular Width	18"W	24"W
		Parametric Width	18"W – 23 ¹⁵ / ₁₆ "W	24"W – 29 ¹⁵ / ₁₆ "W	30"W

Wood Veneer — Return Screen

TS7SCLSSD	30"H	+\$ 863	+\$ 992	+\$1249
	36"H	+\$ 939	+\$1077	+\$1358
	42"H	+\$1014	+\$1163	+\$1465
	48"H	+\$1090	+\$1250	+\$1572
	54"H	+\$1163	+\$1338	+\$1680

Tip: When specifying an L return boundary screen, primary and return screen widths need to be specified. The final price will include the price of both individual screen segments.

► Specification Information, continued on next page

 **For Canadian Pricing**
 Multiply U.S. Price by the Canadian price factor.
 ► See page 1 for details.

Answer Boundary Screens L Return, Single-Connect For Use with Thin Trim Panels, continued

► Specification Information, continued from previous page

Specification Information											
Style Number	Dimensions H	Screen Type	U.S. Base Prices								
			Modular Width	25½"W	31½"W	37½"W	43½"W	49½"W	55½"W	61½"W	67½"W
		Parametric Width	25½"W – 31⅞"W	31½"W – 37⅞"W	37½"W – 43⅞"W	43½"W – 49⅞"W	49½"W – 55⅞"W	55½"W – 61⅞"W	61½"W – 67⅞"W	67½"W – 73⅞"W	73½"W

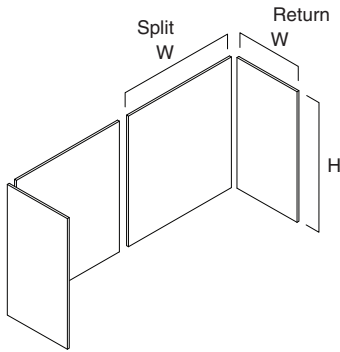

L Return Single-Connect Boundary Screens—Split

High-Pressure Laminate — Primary Screen

TS7SCLSPT	30"H	\$734	\$875	\$1020	\$1162	\$1307	\$1450	\$1595	\$1737	\$1881
	36"H	\$746	\$906	\$1065	\$1221	\$1379	\$1537	\$1696	\$1852	\$2010
	42"H	\$762	\$934	\$1105	\$1276	\$1450	\$1622	\$1793	\$1967	\$2141
	48"H	\$776	\$962	\$1150	\$1335	\$1522	\$1709	\$1896	\$2081	\$2270
	54"H	\$791	\$991	\$1191	\$1393	\$1595	\$1793	\$1996	\$2199	\$2398

Style Number	Dimensions H	Screen Type	U.S. Base Prices		
			Modular Width	18"W	24"W
		Parametric Width	18"W – 23⅞"W	24"W – 29⅞"W	30"W

High-Pressure Laminate — Return Screen

TS7SCLSPT	30"H	+\$661	+\$734	+\$875
	36"H	+\$668	+\$746	+\$906
	42"H	+\$676	+\$762	+\$934
	48"H	+\$682	+\$776	+\$962
	54"H	+\$689	+\$791	+\$991

Tip: When specifying a split L return boundary screen, primary and return screen widths (four total) need to be specified. The final price will include the price of all four individual screen segments.

► Specification Information, continued on next page



For Canadian Pricing

Multiply U.S. Price by the Canadian price factor.

► See page 1 for details.

► Specification Information, continued from previous page

Specification Information											
Style Number	Dimensions H	Screen Type	U.S. Base Prices								
			Modular Width	25½"W	31½"W	37½"W	43½"W	49½"W	55½"W	61½"W	67½"W
		Parametric Width	25½"W – 31½"W	31½"W – 37½"W	37½"W – 43½"W	43½"W – 49½"W	49½"W – 55½"W	55½"W – 61½"W	61½"W – 67½"W	67½"W – 73½"W	73½"W

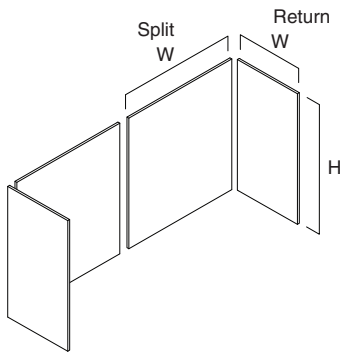

L Return Single-Connect Boundary Screens—Split

Composite Veneer — Primary Screen

TS7SCLSPT	30"H	\$ 992	\$1249	\$1509	\$1765	\$2025	\$2283	\$2543	\$2802	\$3060
	36"H	\$1077	\$1358	\$1639	\$1919	\$2197	\$2477	\$2761	\$3037	\$3317
	42"H	\$1163	\$1465	\$1766	\$2067	\$2368	\$2669	\$2972	\$3274	\$3578
	48"H	\$1250	\$1572	\$1896	\$2218	\$2542	\$2865	\$3189	\$3510	\$3835
	54"H	\$1338	\$1680	\$2024	\$2370	\$2717	\$3057	\$3404	\$3749	\$4094

Style Number	Dimensions H	Screen Type	U.S. Base Prices		
			Modular Width	18"W	24"W
		Parametric Width	18"W – 23½"W	24"W – 29½"W	30"W

Composite Veneer — Return Screen

TS7SCLSPT	30"H	+\$ 863	+\$ 992	+\$1249
	36"H	+\$ 939	+\$1077	+\$1358
	42"H	+\$1014	+\$1163	+\$1465
	48"H	+\$1090	+\$1250	+\$1572
	54"H	+\$1163	+\$1338	+\$1680

► Specification Information, continued on next page

 **For Canadian Pricing**
 Multiply U.S. Price by the Canadian price factor.
 ► See page 1 for details.

Answer Boundary Screens L Return, Single-Connect For Use with Thin Trim Panels, continued

► Specification Information, continued from previous page

Specification Information										
• Style Number	• Dimensions H	• Screen Type	• U.S. Base Prices							
			• Modular Width	25½"W	31½"W	37½"W	43½"W	49½"W	55½"W	61½"W
		• Parametric Width	25½"W – 31½" 16"W	31½"W – 37" 16"W	37½"W – 43" 16"W	43½"W – 49" 16"W	49½"W – 55" 16"W	55½"W – 61" 16"W	61½"W – 67" 16"W	67½"W – 73" 16"W

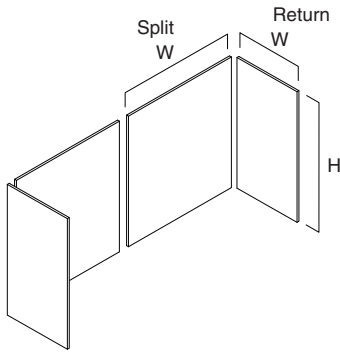

L Return Single-Connect Boundary Screens—Split

Wood Veneer — Primary Screen

TS7SCLSPT	30"H	\$ 992	\$1249	\$1509	\$1765	\$2025	\$2283	\$2543	\$2802	\$3060
	36"H	\$1077	\$1358	\$1639	\$1919	\$2197	\$2477	\$2761	\$3037	\$3317
	42"H	\$1163	\$1465	\$1766	\$2067	\$2368	\$2669	\$2972	\$3274	\$3578
	48"H	\$1250	\$1572	\$1896	\$2218	\$2542	\$2865	\$3189	\$3510	\$3835
	54"H	\$1338	\$1680	\$2024	\$2370	\$2717	\$3057	\$3404	\$3749	\$4094

• Style Number	• Dimensions H	• Screen Type	• U.S. Base Prices		
			• Modular Width	18"W	24"W
		• Parametric Width	18"W – 23½" 16"W	24"W – 29½" 16"W	30"W

Wood Veneer — Return Screen

TS7SCLSPT	30"H	+\$ 863	+\$ 992	+\$1249
	36"H	+\$ 939	+\$1077	+\$1358
	42"H	+\$1014	+\$1163	+\$1465
	48"H	+\$1090	+\$1250	+\$1572
	54"H	+\$1163	+\$1338	+\$1680

Tip: When specifying a split L return boundary screen, primary and return screen widths (four total) need to be specified. The final price will include the price of all four individual screen segments.



For Canadian Pricing

Multiply U.S. Price by the Canadian price factor.

► See page 1 for details.

Answer Boundary Screens

L Return, Dual-Connect For Use with Thin Trim Panels

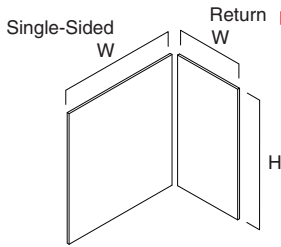

Tip: Additional hardware upcharges are applied only when dual-connect single-sided L return, or dual-connect split L return style numbers are specified.

Tip: When specifying a boundary screen equal to or taller than an Answer panel, order a same height end-of-run junction for height of Answer panel with the omit trim option.

Tip: When attaching boundary screen to Answer panel with stacking segment, order a boundary screen, end-of-run junction, omit trim, add a change-of-height trim, and stacking junction.

Tip: When specifying a boundary screen shorter than Answer panel, order a same height end-of-run junction for height of Answer panel with the omit trim option, and order a change-of-height trim.

Tip: When specifying the paint finish for the bracket cover, select a finish that compliments the selected laminate or veneer finish.

For laminate price group 2 and 3 pricing, please refer to the electronic catalog or SmartTools.

Tip: When specifying a split L return boundary screen, four screen widths will need to be specified.

Tip: Full-fill finish codes can be used to simplify specification of veneer boundary screens being used in settings with full-fill veneer products. The screen will not have the final fill coat applied, but the finish color will be consistent with the full-fill products.

Standard Includes		Required to Specify
<ul style="list-style-type: none"> ▶ Need help? Product details, page 80 • Primary and return screen: High-Pressure Laminate price group 1 or wood group 1 veneer • Edge on laminate screen: plastic, if selected • Height: 30"H–54"H • Width: <ul style="list-style-type: none"> – Single-sided: 27"W–75"W – Split left and right: 25½"W–73½"W • Connecting panel cover: paint price group 1 • 1½" adjustable glides • Attachment hardware 	<ol style="list-style-type: none"> 1 Style number 2 Screen size type (see below under Required Selections) 3 Screen height(s) 4 Height of connecting screen (see below under Required Selections) 5 Screen width(s) 6 Handedness: on single-sided screens, if selected (see below under Required Selections) 7 High-Pressure Laminate or wood veneer color for screen 8 Plastic color number for edge on laminate screen, if selected 9 Grain direction 10 Paint color number for connecting panel cover 11 Options, if selected (see below) 	
▶ See <i>Surface Materials</i> , page 668.		

Required Component	U.S. Price
Additional Hardware	
• Dual-connect single-sided L return	+\$ 58
• Dual-connect split L return	+\$ 86

Required Selections	U.S. Price	Required to Specify
Screen Size Type	<ul style="list-style-type: none"> • Modular No cost • Parametric No cost 	Specify with <i>modular</i> . Specify with <i>parametric</i> .
Height of Connecting Panel	<ul style="list-style-type: none"> • 30"H No cost • 36"H No cost • 42"H No cost • 48"H No cost • 54"H No cost • 60"H No cost • 66"H No cost • 72"H No cost • 78"H No cost • 84"H No cost • 90"H No cost 	Specify with <i>30"H</i> . Specify with <i>36"H</i> . Specify with <i>42"H</i> . Specify with <i>48"H</i> . Specify with <i>54"H</i> . Specify with <i>60"H</i> . Specify with <i>66"H</i> . Specify with <i>72"H</i> . Specify with <i>78"H</i> . Specify with <i>84"H</i> . Specify with <i>90"H</i> .
Handedness (Single-Sided Screens Only)	<ul style="list-style-type: none"> • Right handed No cost • Left handed No cost 	Specify with <i>single-sided right</i> . Specify with <i>single-sided left</i> .

Options	U.S. Price	Required to Specify
Surface Materials		
Screen		
• Laminate price group 2	See information at left	Specify laminate color number.
• Laminate price group 3	See information at left	Specify laminate color number.
• Open Line laminate	+\$201 plus cost of laminate	▶ See <i>Surface Materials Reference Manual</i> .
• Composite veneer group 1	Prices at right	Specify composite veneer color number.
• Composite veneer group 2	+\$201	Specify composite veneer color number.
• Wood group 2	+\$201	Specify wood color number.
• Wood group 3	+\$713	Specify wood color number.
• Customiz stain	No cost	Specify with <i>Customiz stain</i> .
• Full-fill finish on wood group 1	No cost	Specify full-fill finish number.
Connecting panel cover		
• Paint price group 2	+\$ 16	Specify paint color number.
• Paint price group 3	+\$ 34	Specify paint color number.
Laminate wood grain direction		
• No direction	No cost	Specify with <i>no direction</i> .
• Horizontal	No cost	Specify with <i>horizontal grain direction</i> .
• Vertical	No cost	Specify with <i>vertical grain direction</i> .

▶ Options, continued on next page

► Options, continued from previous page

Options	U.S. Price	Required to Specify
Surface Materials, continued		
Wood veneer grain direction		
• No direction	No cost	Specify with <i>no direction</i> .
• Horizontal	No cost	Specify with <i>horizontal grain direction</i> .
• Vertical	No cost	Specify with <i>vertical grain direction</i> .

Specification Information

Style Number	Dimensions H	Screen Type	U.S. Base Prices										
			Modular Width	Parametric Width	27"W	33"W	39"W	45"W	51"W	57"W	63"W	69" W	75"W
		Modular Width	27"W	33"W	39"W	45"W	51"W	57"W	63"W	69"W	75"W		
		Parametric Width	27"W – 32 ¹⁵ / ₁₆ "W	33"W – 38 ¹⁵ / ₁₆ "W	39"W – 44 ¹⁵ / ₁₆ "W	45"W – 50 ¹⁵ / ₁₆ "W	51"W – 56 ¹⁵ / ₁₆ "W	57"W – 62 ¹⁵ / ₁₆ "W	63"W – 68 ¹⁵ / ₁₆ "W	69"W – 74 ¹⁵ / ₁₆ "W	75"W		

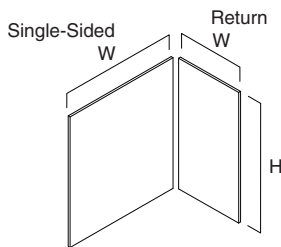

L Return Dual-Connect Boundary Screens—Single-Sided

High-Pressure Laminate — Primary Screen

Style Number	Dimensions H	U.S. Base Prices
TS7DCLSSD	30"H	\$431 \$518 \$603 \$689 \$776 \$ 861 \$ 948 \$1036 \$1122
	36"H	\$446 \$538 \$631 \$726 \$818 \$ 912 \$1007 \$1099 \$1191
	42"H	\$460 \$560 \$661 \$762 \$861 \$ 962 \$1065 \$1162 \$1264
	48"H	\$474 \$582 \$689 \$797 \$906 \$1014 \$1122 \$1227 \$1335
	54"H	\$489 \$603 \$718 \$833 \$948 \$1065 \$1179 \$1293 \$1408

Style Number	Dimensions H	Screen Type	U.S. Base Prices					
			Modular Width	Parametric Width	18"W	24"W	30"W	
		Modular Width	18"W	24"W	30"W			
		Parametric Width	18"W – 23 ¹⁵ / ₁₆ "W	24"W – 29 ¹⁵ / ₁₆ "W	30"W			

High-Pressure Laminate — Return Screen

Style Number	Dimensions H	U.S. Base Prices
TS7DCLSSD	30"H	+\$346 +\$431 +\$518
	36"H	+\$351 +\$446 +\$538
	42"H	+\$359 +\$460 +\$560
	48"H	+\$365 +\$474 +\$582
	54"H	+\$374 +\$489 +\$603

Tip: When specifying an L return boundary screen, primary and return screen widths need to be specified. The final price will include the price of both individual screen segments.

► Specification Information, continued on next page



For Canadian Pricing

Multiply U.S. Price by the Canadian price factor.

► See page 1 for details.

Answer Boundary Screens L Return, Dual-Connect For Use with Thin Trim Panels, continued

► Specification Information, continued from previous page

Specification Information											
Style Number	Dimensions H	Screen Type	U.S. Base Prices								
			Modular Width	27"W	33"W	39"W	45"W	51"W	57"W	63"W	69" W
		Parametric Width	27"W – 32 ¹⁵ / ₁₆ "W	33"W – 38 ¹⁵ / ₁₆ "W	39"W – 44 ¹⁵ / ₁₆ "W	45"W – 50 ¹⁵ / ₁₆ "W	51"W – 56 ¹⁵ / ₁₆ "W	57"W – 62 ¹⁵ / ₁₆ "W	63"W – 68 ¹⁵ / ₁₆ "W	69"W – 74 ¹⁵ / ₁₆ "W	75"W

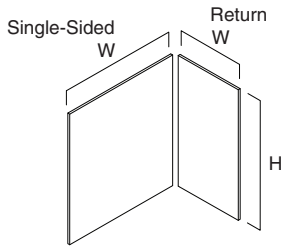

L Return Dual-Connect Boundary Screens—Single-Sided

Composite Veneer — Primary Screen

Style Number	Dimensions H	U.S. Base Prices
TS7DCLSSD	30"H	\$ 790 \$ 1007 \$ 1221 \$ 1435 \$ 1651 \$ 1868 \$ 2082 \$ 2300 \$ 2515
	36"H	\$ 906 \$ 1134 \$ 1365 \$ 1596 \$ 1825 \$ 2055 \$ 2283 \$ 2513 \$ 2741
	42"H	\$ 1020 \$ 1264 \$ 1508 \$ 1753 \$ 1995 \$ 2238 \$ 2487 \$ 2727 \$ 2973
	48"H	\$ 1135 \$ 1394 \$ 1651 \$ 1909 \$ 2170 \$ 2428 \$ 2687 \$ 2943 \$ 3202
	54"H	\$ 1251 \$ 1521 \$ 1795 \$ 2069 \$ 2341 \$ 2615 \$ 2888 \$ 3160 \$ 3432

Style Number	Dimensions H	Screen Type	U.S. Base Prices		
			Modular Width	18"W	24"W
		Parametric Width	18"W – 23 ¹⁵ / ₁₆ "W	24"W – 29 ¹⁵ / ₁₆ "W	30"W

Composite Veneer — Return Screen

Style Number	Dimensions H	U.S. Base Prices
TS7DCLSSD	30"H	+\$ 639 +\$ 790 +\$ 1007
	36"H	+\$ 791 +\$ 906 +\$ 1134
	42"H	+\$ 897 +\$ 1020 +\$ 1264
	48"H	+\$ 1004 +\$ 1135 +\$ 1394
	54"H	+\$ 1113 +\$ 1251 +\$ 1521

Tip: When specifying an L return boundary screen, primary and return screen widths need to be specified. The final price will include the price of both individual screen segments.

► Specification Information, continued on next page



For Canadian Pricing

Multiply U.S. Price by the Canadian price factor.

► See page 1 for details.

► Specification Information, continued from previous page

Specification Information											
Style Number	Dimensions H	Screen Type	U.S. Base Prices								
			Modular Width	27"W	33"W	39"W	45"W	51"W	57"W	63"W	69" W
		Parametric Width	27"W – 32 ¹⁵ / ₁₆ "W	33"W – 38 ¹⁵ / ₁₆ "W	39"W – 44 ¹⁵ / ₁₆ "W	45"W – 50 ¹⁵ / ₁₆ "W	51"W – 56 ¹⁵ / ₁₆ "W	57"W – 62 ¹⁵ / ₁₆ "W	63"W – 68 ¹⁵ / ₁₆ "W	69"W – 74 ¹⁵ / ₁₆ "W	75"W

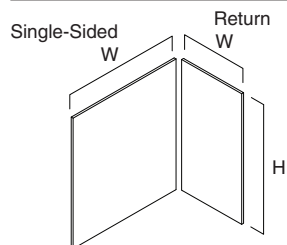

L Return Dual-Connect Boundary Screens—Single-Sided

Wood Veneer — Primary Screen

TS7DCLSSD	30"H	\$ 790	\$1007	\$1221	\$1435	\$1651	\$1868	\$2082	\$2300	\$2515
	36"H	\$ 906	\$1134	\$1365	\$1596	\$1825	\$2055	\$2283	\$2513	\$2741
	42"H	\$1020	\$1264	\$1508	\$1753	\$1995	\$2238	\$2487	\$2727	\$2973
	48"H	\$1135	\$1394	\$1651	\$1909	\$2170	\$2428	\$2687	\$2943	\$3202
	54"H	\$1251	\$1521	\$1795	\$2069	\$2341	\$2615	\$2888	\$3160	\$3432

Style Number	Dimensions H	Screen Type	U.S. Base Prices		
			Modular Width	18"W	24"W
		Parametric Width	18"W – 23 ¹⁵ / ₁₆ "W	24"W – 29 ¹⁵ / ₁₆ "W	30"W

Wood Veneer — Return Screen

TS7DCLSSD	30"H	+\$ 639	+\$ 790	+\$1007
	36"H	+\$ 791	+\$ 906	+\$1134
	42"H	+\$ 897	+\$1020	+\$1264
	48"H	+\$1004	+\$1135	+\$1394
	54"H	+\$1113	+\$1251	+\$1521

Tip: When specifying an L return boundary screen, primary and return screen widths need to be specified. The final price will include the price of both individual screen segments.

► Specification Information, continued on next page

 **For Canadian Pricing**
 Multiply U.S. Price by the Canadian price factor.
 ► See page 1 for details.

Answer Boundary Screens L Return, Dual-Connect For Use with Thin Trim Panels, continued

► Specification Information, continued from previous page

Specification Information											
Style Number	Dimensions H	Screen Type	U.S. Base Prices								
			Modular Width	25½"W	31½"W	37½"W	43½"W	49½"W	55½"W	61½"W	67½"W
		Parametric Width	25½"W – 31⅞"W	31½"W – 37⅞"W	37½"W – 43⅞"W	43½"W – 49⅞"W	49½"W – 55⅞"W	55½"W – 61⅞"W	61½"W – 67⅞"W	67½"W – 73⅞"W	73½"W

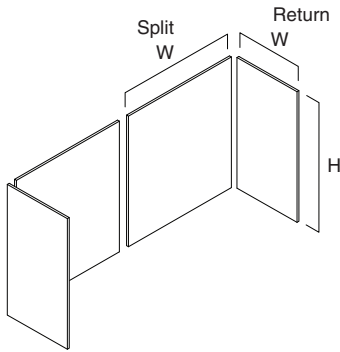

L Return Dual-Connect Boundary Screens—Split

High-Pressure Laminate — Primary Screen

TS7DCLSPT	30"H	\$431	\$518	\$603	\$689	\$776	\$ 861	\$ 948	\$1036	\$1122
	36"H	\$446	\$538	\$631	\$726	\$818	\$ 912	\$1007	\$1099	\$1191
	42"H	\$460	\$560	\$661	\$762	\$861	\$ 962	\$1065	\$1162	\$1264
	48"H	\$474	\$582	\$689	\$797	\$906	\$1014	\$1122	\$1227	\$1335
	54"H	\$489	\$603	\$718	\$833	\$948	\$1065	\$1179	\$1293	\$1408

Style Number	Dimensions H	Screen Type	U.S. Base Prices		
			Modular Width	18"W	24"W
		Parametric Width	18"W – 23⅞"W	24"W – 29⅞"W	30"W

High-Pressure Laminate — Return Screen

TS7DCLSPT	30"H	+\$346	+\$431	+\$518
	36"H	+\$351	+\$446	+\$538
	42"H	+\$359	+\$460	+\$560
	48"H	+\$365	+\$474	+\$582
	54"H	+\$374	+\$489	+\$603

Tip: When specifying a split L return boundary screen, primary and return screen widths (four total) need to be specified. The final price will include the price of all four individual screen segments.

► Specification Information, continued on next page

► Specification Information, continued from previous page

Specification Information											
Style Number	Dimensions H	Screen Type	U.S. Base Prices								
			Modular Width	25½"W	31½"W	37½"W	43½"W	49½"W	55½"W	61½"W	67½"W
		Parametric Width	25½"W – 31½"W	31½"W – 37½"W	37½"W – 43½"W	43½"W – 49½"W	49½"W – 55½"W	55½"W – 61½"W	61½"W – 67½"W	67½"W – 73½"W	73½"W
			31½"W	37½"W	43½"W	49½"W	55½"W	61½"W	67½"W	73½"W	

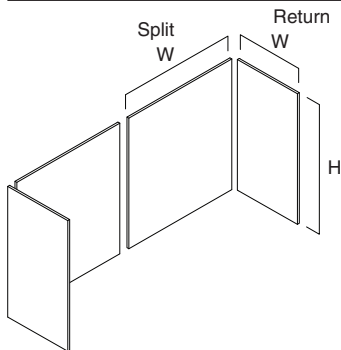

L Return Dual-Connect Boundary Screens — Split

Composite Veneer — Primary Screen

Style Number	Dimensions H	U.S. Base Prices
TS7DCLSPT	30"H	\$ 790 \$ 1007 \$ 1221 \$ 1435 \$ 1651 \$ 1868 \$ 2082 \$ 2300 \$ 2515
	36"H	\$ 906 \$ 1134 \$ 1365 \$ 1596 \$ 1825 \$ 2055 \$ 2283 \$ 2513 \$ 2741
	42"H	\$ 1020 \$ 1264 \$ 1508 \$ 1753 \$ 1995 \$ 2238 \$ 2487 \$ 2727 \$ 2973
	48"H	\$ 1135 \$ 1394 \$ 1651 \$ 1909 \$ 2170 \$ 2428 \$ 2687 \$ 2943 \$ 3202
	54"H	\$ 1251 \$ 1521 \$ 1795 \$ 2069 \$ 2341 \$ 2615 \$ 2888 \$ 3160 \$ 3432

Style Number	Dimensions H	Screen Type	U.S. Base Prices		
			Modular Width	18"W	24"W
		Parametric Width	18"W – 23½"W	24"W – 29½"W	30"W
			23½"W	29½"W	

Composite Veneer — Return Screen

Style Number	Dimensions H	U.S. Base Prices
TS7DCLSPT	30"H	+\$ 639 +\$ 790 +\$ 1007
	36"H	+\$ 791 +\$ 906 +\$ 1134
	42"H	+\$ 897 +\$ 1020 +\$ 1264
	48"H	+\$ 1004 +\$ 1135 +\$ 1394
	54"H	+\$ 1113 +\$ 1251 +\$ 1521

Tip: When specifying a split L return boundary screen, primary and return screen widths (four total) need to be specified. The final price will include the price of all four individual screen segments.

► Specification Information, continued on next page

 **For Canadian Pricing**
 Multiply U.S. Price by the Canadian price factor.
 ► See page 1 for details.

Answer Boundary Screens L Return, Dual-Connect For Use with Thin Trim Panels, continued

► Specification Information, continued from previous page

Specification Information											
Style Number	Dimensions H	Screen Type	U.S. Base Prices								
			Modular Width	25½"W	31½"W	37½"W	43½"W	49½"W	55½"W	61½"W	67½"W
		Parametric Width	25½"W – 31 7/16"W	31½"W – 37 7/16"W	37½"W – 43 7/16"W	43½"W – 49 7/16"W	49½"W – 55 7/16"W	55½"W – 61 7/16"W	61½"W – 67 7/16"W	67½"W – 73 7/16"W	73½"W

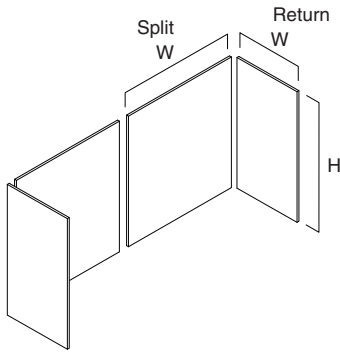

L Return Dual-Connect Boundary Screens — Split

Wood Veneer — Primary Screen

TS7DCLSPT	30"H	\$ 790	\$1007	\$1221	\$1435	\$1651	\$1868	\$2082	\$2300	\$2515
	36"H	\$ 906	\$1134	\$1365	\$1596	\$1825	\$2055	\$2283	\$2513	\$2741
	42"H	\$1020	\$1264	\$1508	\$1753	\$1995	\$2238	\$2487	\$2727	\$2973
	48"H	\$1135	\$1394	\$1651	\$1909	\$2170	\$2428	\$2687	\$2943	\$3202
	54"H	\$1251	\$1521	\$1795	\$2069	\$2341	\$2615	\$2888	\$3160	\$3432

Style Number	Dimensions H	Screen Type	U.S. Base Prices		
			Modular Width	18"W	24"W
		Parametric Width	18"W – 23 15/16"W	24"W – 29 15/16"W	30"W

Wood Veneer — Return Screen

TS7DCLSPT	30"H	+\$ 639	+\$ 790	+\$1007
	36"H	+\$ 791	+\$ 906	+\$1134
	42"H	+\$ 897	+\$1020	+\$1264
	48"H	+\$1004	+\$1135	+\$1394
	54"H	+\$1113	+\$1251	+\$1521

Tip: When specifying a split L return boundary screen, primary and return screen widths (four total) need to be specified. The final price will include the price of all four individual screen segments.



For Canadian Pricing

Multiply U.S. Price by the Canadian price factor.

► See page 1 for details.

Base Trims and Open Base Conversion Kits

Base Trims

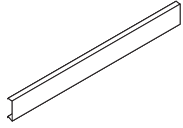

Tip: 18"W base trim is only available in plain (no knockouts).

Standard Includes		Required to Specify
<ul style="list-style-type: none"> ▶ Need help? Product details, page 59 • Base trim with knockouts: paint 	<ul style="list-style-type: none"> 1 Style number 2 Paint color number for trim 3 Options, if selected (see below) ▶ See <i>Surface Materials</i>, page 668. 	

Options	U.S. Price	Required to Specify
Base Trim <ul style="list-style-type: none"> • Plain (24"W to 72"W only) 	No cost	Specify with no knockouts.

Specification Information		
Width	Style Number	U.S. Price
18"	TS718BT	\$28
24"	TS724BT	\$29
30"	TS730BT	\$32
36"	TS736BT	\$34
42"	TS742BT	\$35
48"	TS748BT	\$36
60"	TS760BT	\$44
72"	TS772BT	\$47
:	:	:

Open Base Conversion Kits

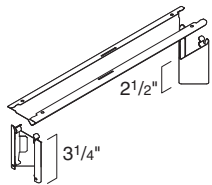

Tip: Open base trim can only be used on junctions manufactured on or after October 10, 2011.

Standard Includes		Required to Specify
<ul style="list-style-type: none"> ▶ Need help? Product details, page 59 • Trim: paint 	<ul style="list-style-type: none"> 1 Style number 2 Paint color number for trim ▶ See <i>Surface Materials</i>, page 668. 	

Specification Information		
Width	Style Number	U.S. Price
18"	TS718OBK	\$52
24"	TS724OBK	\$57
30"	TS730OBK	\$60
36"	TS736OBK	\$63
42"	TS742OBK	\$66
48"	TS748OBK	\$72
60"	TS760OBK	\$76
72"	TS772OBK	\$83
:	:	:



For Canadian Pricing
 Multiply U.S. Price by the Canadian price factor.
 ▶ See page 1 for details.



Specifying Panels—Square and Oval Trim

In-Line Base Panel Junctions—Square Trim	402
In-Line Base Panel Junctions—Oval Trim	403
L, T, and X Base Panel Junctions—Square Trim	404
L, T, and X Base Panel Junctions—Oval Trim	405
End-of-Run Base Panel Junctions—Square Trim	406
End-of-Run Base Panel Junctions—Oval Trim	407
V and Y Base Panel Junctions—Square Trim	408
V and Y Base Panel Junctions—Oval Trim	409
Wall-Start Junctions	410
Brackets	411
Off-Module Panel Connectors	412
Stacking In-Line Panel Junctions—Square and Oval Trims	413
Stacking L, T, and X Panel Junctions— Square and Oval Trims	414
Stacking End-of-Run Panel Junctions— Square and Oval Trims	415
Stacking V and Y Panel Junctions—Square and Oval Trims	416
Stacking Wall-Start Junctions	417
Junctions with Utility Pole—Square Trim	418
Junctions with Utility Pole—Oval Trim	419
Utility Packages	420
Standard Change-of-Height Trims—Square Trim	424
Standard Change-of-Height Trims—Oval Trim	425
Stacking Change-of-Height Trims—Square and Oval Trims	426
Base Horizontal Frame Packages—Square Trim	428
Base Horizontal Frame Packages—Oval Trim	430
Stacking Horizontal Frame Packages	431
Spanning Top Caps—Square Trim	432
Frameless Glass Screens—Square Trim	433

In-Line Base Panel Junctions—Square Trim



Tip: In-line base panel junctions do not require junction cap and trim.

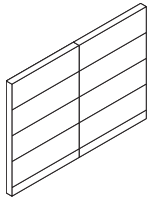

Standard Includes		Required to Specify
▶ Need help? Product details, page 92	<ul style="list-style-type: none"> • Junction • Aligner 	Style number

Specification Information		
Corresponding Panel Height	Style Number	U.S. Price
30"	TS730SIPJ	\$132
42"	TS742SIPJ	\$132
48"	TS748SIPJ	\$132
54"	TS754SIPJ	\$132
66"	TS766SIPJ	\$132
78"	TS778SIPJ	\$189
:	:	:



For Canadian Pricing
Multiply U.S. Price by the Canadian price factor.
▶ See page 1 for details.

In-Line Base Panel Junctions—Oval Trim



Tip: In-line base panel junctions do not require junction cap and trim.

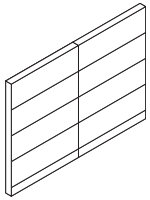

Standard Includes	Required to Specify
-------------------	---------------------

- | | | |
|-----------------------------------------------------------------------------------------|---------------------------------------------------------------------------------|----------------------------------------------------------------|
| <ul style="list-style-type: none"> ▶ Need help? Product details, page 92 | <ul style="list-style-type: none"> • Junction • Aligner | <ul style="list-style-type: none"> Style number |
|-----------------------------------------------------------------------------------------|---------------------------------------------------------------------------------|----------------------------------------------------------------|

Specification Information		
---------------------------	--	--

Corresponding Panel Height	Style Number	U.S. Price
30"	TS730IPJ	\$132
42"	TS742IPJ	\$132
48"	TS748IPJ	\$132
54"	TS754IPJ	\$132
66"	TS766IPJ	\$132
78"	TS778IPJ	\$189
⋮	⋮	⋮

 **For Canadian Pricing**
 Multiply U.S. Price by the Canadian price factor.
 ▶ See page 1 for details.

L, T, and X Base Panel Junctions—Square Trim

Standard Includes	Required to Specify
<ul style="list-style-type: none"> ▶ Need help? Product details, page 92 • Junction • Trim on L and T junction: paint price group 1 • Junction cap on L, T, and X junction: paint price group 1 • Aligners 	<ul style="list-style-type: none"> 1 Style number 2 Paint color number for trim 3 Paint color number for junction cap 4 Options, if selected (see below) ▶ See <i>Surface Materials</i>, page 668.

Tip: Painted trim is standard, and fabric trim is optional, on all base panel junctions.

Tip: 78"H fabric-covered junctions allow fabric in the vertical application only.

Tip: For further information about fabric direction, ▶ see page 674.

Options	U.S. Price	Required to Specify
Surface Materials Trim <ul style="list-style-type: none"> • Paint price group 1 • Paint price group 2 • Paint price group 3 	<ul style="list-style-type: none"> No cost +\$ 16 +\$ 34 	<ul style="list-style-type: none"> Specify paint color number. Specify paint color number. Specify paint color number.
Trim on L and T junctions <ul style="list-style-type: none"> • Fabric price group 1, 2, 3, 4, 5, or COM • Fabric direction <ul style="list-style-type: none"> –Horizontal application (standard) –Vertical application 	<ul style="list-style-type: none"> +\$124 No cost No cost 	<ul style="list-style-type: none"> Specify fabric color number for trim. Specify with horizontal application. Specify with vertical application.

Specification Information

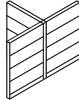
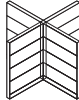
L Base Panel Junctions with Square Trim			T Base Panel Junctions with Square Trim			X Base Panel Junctions with Square Trim		
								
•Corresponding Panel Height	•Style Number	•U.S. Base Price	•Style Number	•U.S. Base Price	•Style Number	•U.S. Base Price		

Painted Junction Cap

Panel Height	Style Number	U.S. Base Price	Style Number	U.S. Base Price	Style Number	U.S. Base Price
30"	TS730SLPJ	\$288	TS730STPJ	\$288	TS730XPJ	\$288
42"	TS742SLPJ	\$288	TS742STPJ	\$288	TS742XPJ	\$288
48"	TS748SLPJ	\$288	TS748STPJ	\$288	TS748XPJ	\$288
54"	TS754SLPJ	\$288	TS754STPJ	\$288	TS754XPJ	\$288
66"	TS766SLPJ	\$288	TS766STPJ	\$288	TS766XPJ	\$288
78"	TS778SLPJ	\$412	TS778STPJ	\$412	TS778XPJ	\$412



For Canadian Pricing
 Multiply U.S. Price by the Canadian price factor.
 ▶ See page 1 for details.

L, T, and X Base Panel Junctions—Oval Trim

Standard Includes	Required to Specify
<ul style="list-style-type: none"> ▶ Need help? Product details, page 92 • Junction • Trim on L and T junction: paint price group 1 • Junction cap on L, T, and X junction: plastic price group 1 • Aligners 	<ol style="list-style-type: none"> 1 Style number 2 Paint color number for trim 3 Plastic color number for junction cap 4 Options, if selected (see below) <p>▶ See <i>Surface Materials</i>, page 668.</p>

Tip: Painted trim is standard, and fabric trim is optional, on all base panel junctions.

Tip: 78"H fabric-covered junctions allow fabric in the vertical application only.

Tip: For further information about fabric direction, ▶ see page 674.

Options	U.S. Price	Required to Specify
Surface Materials <ul style="list-style-type: none"> • Paint price group 1 • Paint price group 2 • Paint price group 3 	<ul style="list-style-type: none"> No cost +\$ 16 +\$ 34 	<ul style="list-style-type: none"> Specify paint color number. Specify paint color number. Specify paint color number.
Trim on L and T junctions <ul style="list-style-type: none"> • Fabric price group 1, 2, 3, 4, 5, or COM • Fabric direction <ul style="list-style-type: none"> –Horizontal application (standard) –Vertical application 	<ul style="list-style-type: none"> +\$124 No cost No cost 	<ul style="list-style-type: none"> Specify fabric color number for trim. Specify with <i>horizontal application</i>. Specify with <i>vertical application</i>.

Specification Information

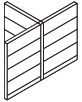
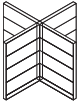
L Base Panel Junctions with Oval Trim			T Base Panel Junctions with Oval Trim			X Base Panel Junctions with Oval Trim		
								
•Corresponding Panel Height	•Style Number	•U.S. Base Price	•Style Number	•U.S. Base Price	•Style Number	•U.S. Base Price		

Plastic Junction Cap						
Height	L Style Number	L U.S. Price	T Style Number	T U.S. Price	X Style Number	X U.S. Price
30"	TS730LPJ	\$343	TS730TPJ	\$343	TS730XPJ	\$343
42"	TS742LPJ	\$343	TS742TPJ	\$343	TS742XPJ	\$343
48"	TS748LPJ	\$343	TS748TPJ	\$343	TS748XPJ	\$343
54"	TS754LPJ	\$343	TS754TPJ	\$343	TS754XPJ	\$343
66"	TS766LPJ	\$343	TS766TPJ	\$343	TS766XPJ	\$343
78"	TS778LPJ	\$479	TS778TPJ	\$479	TS778XPJ	\$479

 **For Canadian Pricing**
 Multiply U.S. Price by the Canadian price factor.
 ▶ See page 1 for details.

End-of-Run Base Panel Junctions—Square Trim



Tip: End-of-run trim adds 1" to footprint.

Tip: Painted trim is standard, and fabric trim is optional, on all base panel junctions.

Tip: 78"H fabric-covered junctions allow fabric in the vertical application only.

Tip: For further information about fabric direction, see page 674.

Standard Includes	Required to Specify
<ul style="list-style-type: none"> ▶ Need help? Product details, page 92 • Junction • Trim on end-of-run junction: paint price group 1 • Junction cap on end-of-run junction: paint price group 1 	<ul style="list-style-type: none"> 1 Style number 2 Paint color number for trim 3 Paint color number for junction cap 4 Options, if selected (see below) ▶ See <i>Surface Materials</i>, page 668.

Options	U.S. Price	Required to Specify
Surface Materials Trim <ul style="list-style-type: none"> • Paint price group 1 • Paint price group 2 • Paint price group 3 	No cost +\$ 16 +\$ 34	Specify paint color number. Specify paint color number. Specify paint color number.
<ul style="list-style-type: none"> • Fabric price group 1, 2, 3, 4, 5, or COM • Fabric direction <ul style="list-style-type: none"> –Horizontal application (standard) –Vertical application 	+\$124 No cost No cost	Specify fabric color number for trim. Specify <i>with horizontal application</i> . Specify <i>with vertical application</i> .

Specification Information		
Corresponding Panel Height	Style Number	U.S. Base Price

Painted Junction Cap		
30"	TS730SEPJ	\$189
42"	TS742SEPJ	\$189
48"	TS748SEPJ	\$189
54"	TS754SEPJ	\$189
66"	TS766SEPJ	\$189
78"	TS778SEPJ	\$268



For Canadian Pricing
 Multiply U.S. Price by the Canadian price factor.
 ▶ See page 1 for details.

End-of-Run Base Panel Junctions—Oval Trim



Tip: End-of-run trim adds 1" to footprint.

Tip: Painted trim is standard, and fabric trim is optional, on all base panel junctions.

Tip: 78"H fabric-covered junctions allow fabric in the vertical application only.

Tip: For further information about fabric direction, see page 674.

Standard Includes	Required to Specify
<ul style="list-style-type: none"> ▶ Need help? Product details, page 92 • Junction • Trim on end-of-run junction: paint price group 1 • Junction cap on end-of-run junction: plastic price group 1 	<ul style="list-style-type: none"> 1 Style number 2 Paint color number for trim 3 Plastic color number for junction cap 4 Options, if selected (see below) ▶ See <i>Surface Materials</i>, page 668.

Options	U.S. Price	Required to Specify
Surface Materials <ul style="list-style-type: none"> • Trim • Paint price group 1 • Paint price group 2 • Paint price group 3 	<ul style="list-style-type: none"> No cost +\$ 16 +\$ 34 	<ul style="list-style-type: none"> Specify paint color number. Specify paint color number. Specify paint color number.
<ul style="list-style-type: none"> • Fabric price group 1, 2, 3, 4, 5, or COM • Fabric direction –Horizontal application (standard) –Vertical application 	<ul style="list-style-type: none"> +\$124 No cost No cost 	<ul style="list-style-type: none"> Specify fabric color number for trim. Specify with <i>horizontal application</i>. Specify with <i>vertical application</i>.

Specification Information		
Corresponding Panel Height	Style Number	U.S. Base Price

Plastic Junction Cap		
30"	TS730EPJ	\$217
42"	TS742EPJ	\$217
48"	TS748EPJ	\$217
54"	TS754EPJ	\$217
66"	TS766EPJ	\$217
78"	TS778EPJ	\$317
:	:	:

 **For Canadian Pricing**
 Multiply U.S. Price by the Canadian price factor.
 ▶ See page 1 for details.

V and Y Base Panel Junctions—Square Trim

Standard Includes	Required to Specify
<ul style="list-style-type: none"> ▶ Need help? Product details, page 92 • Junction • Trim on V junction: paint price group 1 • Junction cap on V and Y junction: paint price group 1 • Aligners 	<ul style="list-style-type: none"> 1 Style number 2 Paint color number for trim 3 Paint color number for junction cap 4 Options, if selected (see below) ▶ See <i>Surface Materials</i>, page 668.



Tip: Painted trim is standard, and fabric trim is optional, on all base panel junctions.

Tip: 78"H fabric-covered junctions allow fabric in the vertical application only.

Tip: For further information about fabric direction, ▶ see page 674.

Options	U.S. Price	Required to Specify
Surface Materials Trim <ul style="list-style-type: none"> • Paint price group 1 • Paint price group 2 • Paint price group 3 	No cost +\$ 16 +\$ 34	Specify paint color number. Specify paint color number. Specify paint color number.
V junction trim <ul style="list-style-type: none"> • Fabric price group 1, 2, 3, 4, 5, or COM • Fabric direction <ul style="list-style-type: none"> –Horizontal application (standard) –Vertical application 	+\$124 No cost No cost	Specify fabric color number for trim. Specify <i>with horizontal application</i> . Specify <i>with vertical application</i> .

Specification Information

V Base Panel Junctions with Square Trim			Y Base Panel Junctions with Square Trim		
					
• Corresponding Panel Height	• Style Number	• U.S. Base Price	• Style Number	• U.S. Base Price	
:	:	:	:	:	

Painted Junction Cap

Panel Height	Style Number	U.S. Base Price	Style Number	U.S. Base Price
30"	TS730SVPJ	\$447	TS730SYPJ	\$447
42"	TS742SVPJ	\$447	TS742SYPJ	\$447
48"	TS748SVPJ	\$447	TS748SYPJ	\$447
54"	TS754SVPJ	\$447	TS754SYPJ	\$447
66"	TS766SVPJ	\$447	TS766SYPJ	\$447
78"	TS778SVPJ	\$615	TS778SYPJ	\$615
:	:	:	:	:



For Canadian Pricing
 Multiply U.S. Price by the Canadian price factor.
 ▶ See page 1 for details.

V and Y Base Panel Junctions—Oval Trim

V and Y Base
Panel Junctions—
Oval Trim

Standard Includes		Required to Specify
<ul style="list-style-type: none"> ▶ Need help? Product details, page 92 	<ul style="list-style-type: none"> • Junction • Trim on V junction: paint price group 1 • Junction cap on V and Y junction: plastic price group 1 • Aligners 	<ol style="list-style-type: none"> 1 Style number 2 Paint color number for trim 3 Plastic color number for junction cap 4 Options, if selected (see below) <ul style="list-style-type: none"> ▶ See <i>Surface Materials</i>, page 668.

Tip: Painted trim is standard, and fabric trim is optional, on all base panel junctions.

Tip: 78"H fabric-covered junctions allow fabric in the vertical application only.

Tip: For further information about fabric direction, ▶ Page 674.

Options	U.S. Price	Required to Specify
Surface Materials <ul style="list-style-type: none"> • Trim • Paint price group 1 • Paint price group 2 • Paint price group 3 	<ul style="list-style-type: none"> No cost +\$ 16 +\$ 34 	<ul style="list-style-type: none"> Specify paint color number. Specify paint color number. Specify paint color number.
<ul style="list-style-type: none"> • V junction trim • Fabric price group 1, 2, 3, 4, 5, or COM • Fabric direction –Horizontal application (standard) –Vertical application 	<ul style="list-style-type: none"> +\$124 No cost No cost 	<ul style="list-style-type: none"> Specify fabric color number for trim. Specify with <i>horizontal application</i>. Specify with <i>vertical application</i>.

Specification Information

V Base Panel Junctions with Oval Trim



Y Base Panel Junctions with Oval Trim



Corresponding Panel Height	Style Number	U.S. Base Price	Style Number	U.S. Base Price
----------------------------	--------------	-----------------	--------------	-----------------

Plastic Junction Cap

30"	TS730VPJ	\$521	TS730YPJ	\$521
42"	TS742VPJ	\$521	TS742YPJ	\$521
48"	TS748VPJ	\$521	TS748YPJ	\$521
54"	TS754VPJ	\$521	TS754YPJ	\$521
66"	TS766VPJ	\$521	TS766YPJ	\$521
78"	TS778VPJ	\$728	TS778YPJ	\$728

 **For Canadian Pricing**
Multiply U.S. Price by the Canadian price factor.
▶ See page 1 for details.

Wall-Start Junctions



Tip: When using in an off-module application, off-module panel connector must be ordered separately.

▶ Page 412

Standard Includes	Required to Specify
-------------------	---------------------

▶ Need help? Product details, page 93	• Junction Style number
---------------------------------------------	--------------------------------

Specification Information		
---------------------------	--	--

Height	Style Number	U.S. Price
42"	TS742WPJ	\$323
48"	TS748WPJ	\$323
54"	TS754WPJ	\$323
66"	TS766WPJ	\$323
78"	TS778WPJ	\$449
:	:	:



For Canadian Pricing

Multiply U.S. Price by the Canadian price factor.

▶ See page 1 for details.

Brackets

Floor Anchor Bracket



Tip: Floor anchor bolts are not included.

Standard Includes	Required to Specify
-------------------	---------------------

- | | | |
|-----------------------------------------------------------------------------------------|------------------------------------------------------------------------------------------------------|----------------------------------------------------------------|
| <ul style="list-style-type: none"> ▶ Need help? Product details, page 93 | <ul style="list-style-type: none"> • Two-piece floor anchor bracket: black paint only | <ul style="list-style-type: none"> Style number |
|-----------------------------------------------------------------------------------------|------------------------------------------------------------------------------------------------------|----------------------------------------------------------------|

Specification Information		
---------------------------	--	--

• Style Number	• U.S. Price
CBRKTS	\$63

Junction Stabilizer Brackets

Tip: Junction stabilizer bracket blocks power routing in the base and just above the base areas. Lay-in cable routing in the base is also blocked by the bracket.

Standard Includes	Required to Specify
-------------------	---------------------

- | | | |
|-----------------------------------------------------------------------------------------|-------------------------------------------------------------------------------|----------------------------------------------------------------|
| <ul style="list-style-type: none"> ▶ Need help? Product details, page 93 | <ul style="list-style-type: none"> • Bracket: black paint only | <ul style="list-style-type: none"> Style number |
|-----------------------------------------------------------------------------------------|-------------------------------------------------------------------------------|----------------------------------------------------------------|

Specification Information		
---------------------------	--	--

• Height	• Style Number	• U.S. Price
10 1/2"	TS7SBNJ	\$113

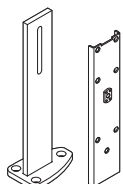

Tip: Junctions manufactured on or after October 10, 2011 will only work with TS7SBNJ junction stabilizer bracket.

10 1/2"	TS7SB	\$113
---------	-------	-------

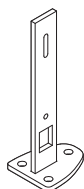

Tip: Junctions manufactured before October 10, 2011 will only work with TS7SB junction stabilizer bracket.



For Canadian Pricing
 Multiply U.S. Price by the Canadian price factor.
 ▶ See page 1 for details.

Off-Module Panel Connectors

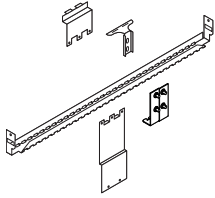

Tip: Must be used with wall-start junctions, ordered separately.

▶ Page 410

Tip: Off-module panel connector works with thin, square, and oval style trims. Top cap filler included in package is only used with oval style trims. Thin and square style trims do not require a top cap filler.

Tip: Wall-start junctions manufactured before October 2002 will not work with off-module panel connectors.

Tip: When using with wall-start junction manufactured before October 10, 2011, the bottom bracket must be replaced with part number T500938MP from Service Parts.

Standard Includes		Required to Specify
▶ Need help? Product details, page 98	<ul style="list-style-type: none"> • Top and bottom bracket • Bottom channel • Top cap filler (oval style): plastic 	<ul style="list-style-type: none"> 1 Style number 2 Plastic color number for filler <p>▶ See <i>Surface Materials</i>, page 668.</p>

Specification Information		
Width	Style Number	U.S. Price
24"	TS724BKT	\$409
30"	TS730BKT	\$409
36"	TS736BKT	\$409
42"	TS742BKT	\$409
48"	TS748BKT	\$409
60"	TS760BKT	\$409
72"	TS772BKT	\$409



For Canadian Pricing

Multiply U.S. Price by the Canadian price factor.

▶ See page 1 for details.

Stacking In-Line Panel Junctions—Square and Oval Trims

Stacking In-Line
Panel Junctions—
Square and
Oval Trims



Tip: Stacking in-line junctions do not require junction cap and trim.

Standard Includes		Required to Specify
▶ Need help? Product details, page 100	<ul style="list-style-type: none"> • Junction • Fork connectors 	Style number

Specification Information		
• Height	• Style Number	• U.S. Price
12"	TS712IPJS	\$178
18"	TS718IPJS	\$178
24"	TS724IPJS	\$178
:	:	:

 **For Canadian Pricing**
Multiply U.S. Price by the
Canadian price factor.
▶ See page 1 for details.

Stacking L, T, and X Panel Junctions—Square and Oval Trims



Tip: Junction cap is not included. Use the junction cap from the base junction you are stacking on.

Standard Includes		Required to Specify
<ul style="list-style-type: none"> ▶ Need help? Product details, page 100 	<ul style="list-style-type: none"> • Junction • Trim on L and T junctions: paint price group 1 • Fork connectors • Stacking trim aligner on L and T junctions: black plastic only 	<ul style="list-style-type: none"> 1 Style number 2 Paint color number for trim 3 Options, if selected (see below) ▶ See <i>Surface Materials</i>, page 668.

Options	U.S. Price	Required to Specify
Surface Materials	Trim <ul style="list-style-type: none"> • Paint price group 1 No cost • Paint price group 2 +\$ 16 • Paint price group 3 +\$ 34 	<ul style="list-style-type: none"> Specify paint color number. Specify paint color number. Specify paint color number.
Steel L and T junction trim only		
<ul style="list-style-type: none"> • Fabric price group 1, 2, 3, 4, 5, or COM +\$124 		<ul style="list-style-type: none"> Specify fabric color number for trim.
<ul style="list-style-type: none"> • Fabric direction <ul style="list-style-type: none"> –Horizontal application (standard) No cost –Vertical application No cost 		<ul style="list-style-type: none"> Specify <i>with horizontal application</i>. Specify <i>with vertical application</i>.

Tip: For further information about fabric direction, ▶ Page 674.

Specification Information

L Panel Junctions			T Panel Junctions		X Panel Junctions	
						
• Height	• Style Number	• U.S. Base Price	• Style Number	• U.S. Base Price	• Style Number	• U.S. Base Price

Steel Trim						
12"	TS712LPJS	\$519	TS712TPJS	\$519	TS712XPJS	\$461
18"	TS718LPJS	\$546	TS718TPJS	\$546	TS718XPJS	\$486
24"	TS724LPJS	\$519	TS724TPJS	\$519	TS724XPJS	\$484
:	:	:	:	:	:	:



For Canadian Pricing
 Multiply U.S. Price by the Canadian price factor.
 ▶ See page 1 for details.

Stacking End-of-Run Panel Junctions—Square and Oval Trims

Stacking End-of-Run Panel Junctions—Square and Oval Trims



Tip: Junction cap is not included. Use the junction cap from the base junction you are stacking on.

Tip: For further information about fabric direction, ▶ Page 674.

Standard Includes		Required to Specify
▶ Need help? Product details, page 100	<ul style="list-style-type: none"> Junction Trim on end-of-run junction: paint price group 1 Fork connectors Stacking trim aligner: black plastic only 	1 Style number 2 Paint color number for trim 3 Options, if selected (see below) ▶ See <i>Surface Materials</i> , page 668.

Surface Materials	Options	U.S. Price	Required to Specify
	Trim		
	• Paint price group 1	No cost	Specify paint color number.
	• Paint price group 2	+\$ 16	Specify paint color number.
	• Paint price group 3	+\$ 34	Specify paint color number.
	Steel end-of-run junction trim		
	• Fabric price group 1, 2, 3, 4, 5, or COM	+\$124	Specify fabric color number for trim.
	• Fabric direction		
	–Horizontal application (standard)	No cost	Specify <i>with horizontal application</i> .
	–Vertical application	No cost	Specify <i>with vertical application</i> .

Specification Information		
Height	Style Number	U.S. Base Price

Steel Trim		
Height	Style Number	U.S. Base Price
12"	TS712EPJS	\$288
18"	TS718EPJS	\$288
24"	TS724EPJS	\$288

 **For Canadian Pricing**
 Multiply U.S. Price by the Canadian price factor.
 ▶ See page 1 for details.

Stacking V and Y Panel Junctions—Square and Oval Trims



Tip: Junction cap is not included. Use the junction cap from the base junction you are stacking on.

Standard Includes		Required to Specify
<ul style="list-style-type: none"> ▶ Need help? Product details, page 100 	<ul style="list-style-type: none"> • Junction • Trim on V junctions: paint price group 1 • Fork connectors • Stacking trim aligner on V junctions: black plastic only 	<ul style="list-style-type: none"> 1 Style number 2 Paint color number for trim 3 Options, if selected (see below) ▶ See <i>Surface Materials</i>, page 668.

Options	U.S. Price	Required to Specify
Surface Materials Trim <ul style="list-style-type: none"> • Paint price group 1 • Paint price group 2 • Paint price group 3 	<ul style="list-style-type: none"> No cost +\$ 16 +\$ 34 	<ul style="list-style-type: none"> Specify paint color number. Specify paint color number. Specify paint color number.
Steel V junction trim only		
<ul style="list-style-type: none"> • Fabric price group 1, 2, 3, 4, 5, or COM • Fabric direction <ul style="list-style-type: none"> –Horizontal application (standard) –Vertical application 	<ul style="list-style-type: none"> +\$124 No cost No cost 	<ul style="list-style-type: none"> Specify fabric color number for trim. Specify <i>with horizontal application</i>. Specify <i>with vertical application</i>.

Tip: For further information about fabric direction,
▶ Page 674.

Specification Information

V Panel Junctions			Y Panel Junctions	
				
• Height	• Style Number	• U.S. Base Price	• Style Number	• U.S. Base Price

Steel Trim				
12"	TS712VPJS	\$687	TS712YPJS	\$610
18"	TS718VPJS	\$687	TS718YPJS	\$610
24"	TS724VPJS	\$687	TS724YPJS	\$626



For Canadian Pricing
 Multiply U.S. Price by the Canadian price factor.
 ▶ See page 1 for details.

Stacking Wall-Start Junctions



Standard Includes	Required to Specify
<ul style="list-style-type: none"> • Junction • Fork connector 	Style number

Specification Information		
• Height	• Style Number	• U.S. Price
12"	TS712WPJS	\$486
18"	TS718WPJS	\$486
24"	TS724WPJS	\$486
•	•	•

 **For Canadian Pricing**
 Multiply U.S. Price by the Canadian price factor.
 ▶ See page 1 for details.

Panels—Square and Oval Trim

Junctions with Utility Pole—Square Trim

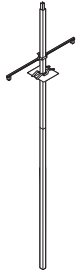

Tip: Order multipurpose power infeed separately.
▶ Page 492

Standard Includes		Required to Specify
▶ Need help? Product details, page 172	<ul style="list-style-type: none"> Junction Upright vertical trim on L and in-line: paint price group 1 Junction cap on L, in-line, and T junctions: paint Utility pole: paint price group 1 Ceiling trim plate: white paint only Mounting brackets 	<ol style="list-style-type: none"> Style number Paint color number for upright and utility pole Paint color number for junction cap Options, if selected (see below) <p>▶ See <i>Surface Materials</i>, page 668.</p>

Options	U.S. Price	Required to Specify
Surface Materials	<ul style="list-style-type: none"> Paint price group 1: No cost Paint price group 2: +\$16 Paint price group 3: +\$34 	Specify paint color number. Specify paint color number. Specify paint color number.

Specification Information		
Corresponding Panel Height	Style Number	U.S. Base Price

L and In-Line Panel Junctions with Utility Pole

42"	TS742SLUP	\$1055
48"	TS748SLUP	\$1020
54"	TS754SLUP	\$1055
66"	TS766SLUP	\$1055
78"	TS778SLUP	\$1162
:	:	:

T Panel Junctions with Utility Pole

42"	TS742STUP	\$1055
48"	TS748STUP	\$1020
54"	TS754STUP	\$1055
66"	TS766STUP	\$1055
78"	TS778STUP	\$1162
:	:	:

Tip: End-of-run junctions with utility pole can be used with thin trim also.

End-of-Run Junctions with Utility Pole

42"	TS742SERUP	\$ 643
48"	TS748SERUP	\$ 594
54"	TS754SERUP	\$ 643
66"	TS766SERUP	\$ 643
78"	TS778SERUP	\$ 670
:	:	:



For Canadian Pricing
Multiply U.S. Price by the Canadian price factor.
▶ See page 1 for details.

Junctions with Utility Pole—Oval Trim

Junctions with Utility Pole—Oval Trim

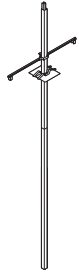

Tip: Order multipurpose power infeed separately.
▶ Page 492

Standard Includes		Required to Specify
▶ Need help? Product details, page 172	<ul style="list-style-type: none"> Junction Upright vertical trim on L and in-line: paint price group 1 Junction cap on L, in-line, and T junctions: plastic Utility pole: paint price group 1 Ceiling trim plate: white paint only Mounting brackets 	<ol style="list-style-type: none"> Style number Paint color number for upright and utility pole Plastic color number for junction cap Options, if selected (see below) <p>▶ See <i>Surface Materials</i>, page 668.</p>

Options	U.S. Price	Required to Specify
Surface Materials	<ul style="list-style-type: none"> Paint price group 1: No cost Paint price group 2: +\$16 Paint price group 3: +\$34 	Specify paint color number.

Specification Information		
Corresponding Panel Height	Style Number	U.S. Base Price

L and In-Line Panel Junctions with Utility Pole

42"	TS742LUP	\$1240
48"	TS748LUP	\$1199
54"	TS754LUP	\$1240
66"	TS766LUP	\$1240
78"	TS778LUP	\$1367
:	:	:

T Panel Junctions with Utility Pole

42"	TS742TUP	\$1240
48"	TS748TUP	\$1199
54"	TS754TUP	\$1240
66"	TS766TUP	\$1240
78"	TS778TUP	\$1367
:	:	:

End-of-Run Junctions with Utility Pole

42"	TS742ERUP	\$ 754
48"	TS748ERUP	\$ 731
54"	TS754ERUP	\$ 754
66"	TS766ERUP	\$ 754
78"	TS778ERUP	\$ 790
:	:	:

Tip: End-of-run junctions with utility pole can be used with thin trim also.



For Canadian Pricing
Multiply U.S. Price by the Canadian price factor.
▶ See page 1 for details.

Utility Packages

Ceiling-Access Lay-In Utility Packages—Square Trim

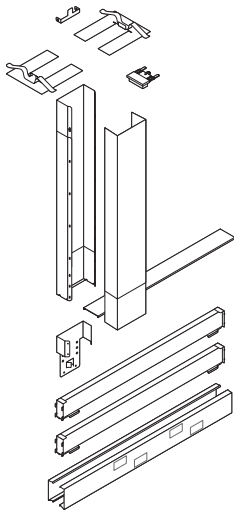

Tip: Order multipurpose power infeed separately.
▶ Page 492

Standard Includes	Required to Specify
-------------------	---------------------

- | | | |
|------------------------------------------------------------------------------------------|-------------------------------------------------------------------------------------------------------------------------------------------------------------------------------------------------------------------------------------------------------------------------------------------------------------------|-------------------------------------------------------------------------------------------------------------------------------------------------------------------------------------------------------------------------------------------------------------------|
| <ul style="list-style-type: none"> ▶ Need help? Product details, page 166 | <ul style="list-style-type: none"> • Utility carrier and cover, one top cap, and two standard base trims: paint price group 1 • Two lay-in horizontal connecting bars: black paint only • Ceiling attachment hardware • Junction cap for end-of-run applications: paint | <ul style="list-style-type: none"> 1 Style number 2 Paint color number for utility carrier and cover, top cap, base trim, and junction cap 3 Options, if selected (see below) ▶ See <i>Surface Materials</i>, page 668. |
|------------------------------------------------------------------------------------------|-------------------------------------------------------------------------------------------------------------------------------------------------------------------------------------------------------------------------------------------------------------------------------------------------------------------|-------------------------------------------------------------------------------------------------------------------------------------------------------------------------------------------------------------------------------------------------------------------|

Options	U.S. Price	Required to Specify
---------	------------	---------------------

Surface Materials <ul style="list-style-type: none"> • Paint price group 1 • Paint price group 2 • Paint price group 3 	<ul style="list-style-type: none"> No cost +\$16 +\$34 	<ul style="list-style-type: none"> Specify paint color number. Specify paint color number. Specify paint color number.
Change-of-Height Top Cap <ul style="list-style-type: none"> • Change-of-height at one end of top cap, slim • Change-of-height at one end of top cap, cable management 	<ul style="list-style-type: none"> +\$ 7 +\$ 7 	<ul style="list-style-type: none"> Specify <i>with change-of-height, one end slim.</i> Specify <i>with change-of-height, one end cable management.</i>
Base Cable Tray <ul style="list-style-type: none"> • Base cable tray 	<ul style="list-style-type: none"> +\$ 5 	<ul style="list-style-type: none"> Specify <i>with base cable tray.</i>

Specification Information		
Width	Style Number	U.S. Base Price

30"	TS730SSUC	\$1297
36"	TS736SSUC	\$1372
42"	TS742SSUC	\$1495
48"	TS748SSUC	\$1628
:	:	:



For Canadian Pricing
Multiply U.S. Price by the Canadian price factor.
▶ See page 1 for details.

Ceiling-Access Lay-In Utility Packages—Oval Trim

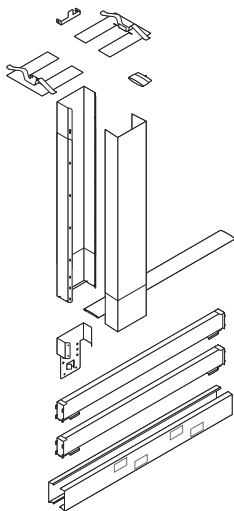

Tip: Order multipurpose power infeed separately.
▶ Page 492

Standard Includes		Required to Specify	
-------------------	--	---------------------	--

- | | | | |
|------------------------------------------------------------------------------------------|---------------------------------------------------------------------------------------------------------------------------------------------------------------------------------------------------------------------------------------------------------------------------------------------------------------------|---------------------------------------------------------------------------------------------------------------------------------------------------------------------------------------------------------------------------------------------------|---------------------------------------------------------------------------------------------|
| <ul style="list-style-type: none"> ▶ Need help? Product details, page 166 | <ul style="list-style-type: none"> • Utility carrier and cover, one top cap, and two standard base trims: paint price group 1 • Two lay-in horizontal connecting bars: black paint only • Ceiling attachment hardware • Junction cap for end-of-run applications: plastic | <ol style="list-style-type: none"> 1 Style number 2 Paint color number for utility carrier and cover, top cap, and base trim 3 Plastic color number for junction cap 4 Options, if selected (see below) | <ul style="list-style-type: none"> ▶ See <i>Surface Materials</i>, page 668. |
|------------------------------------------------------------------------------------------|---------------------------------------------------------------------------------------------------------------------------------------------------------------------------------------------------------------------------------------------------------------------------------------------------------------------|---------------------------------------------------------------------------------------------------------------------------------------------------------------------------------------------------------------------------------------------------|---------------------------------------------------------------------------------------------|

Options	U.S. Price	Required to Specify
---------	------------	---------------------

Surface Materials <ul style="list-style-type: none"> • Paint price group 1 • Paint price group 2 • Paint price group 3 	No cost +\$16 +\$34	Specify paint color number. Specify paint color number. Specify paint color number.
Change-of-Height Shortened Top Cap <ul style="list-style-type: none"> • Change-of-height cable routing at one end of top cap 	+\$ 7	Specify with <i>change-of-height, one end.</i>
Base Cable Tray <ul style="list-style-type: none"> • Base cable tray 	+\$ 5	Specify with <i>base cable tray.</i>

Specification Information		
Width	Style Number	U.S. Base Price

30"	TS730SUC	\$1522
36"	TS736SUC	\$1615
42"	TS742SUC	\$1758
48"	TS748SUC	\$1914
:	:	:

 **For Canadian Pricing**
 Multiply U.S. Price by the Canadian price factor.
 ▶ See page 1 for details.

Floor-Access Lay-In Utility Packages—Square Trim

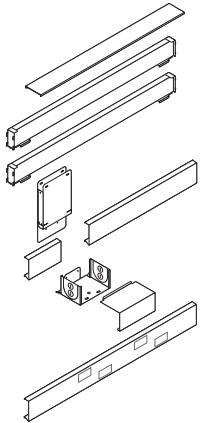

Tip: 30"W lay-in utility package with floor-access is only available with change-of-height top cap at one end.

Tip: Order multipurpose power infeed separately.
▶ Page 492

Standard Includes	Required to Specify
<ul style="list-style-type: none"> ▶ Need help? Product details, page 168 • One top cap, one standard base trim, one modified base trim, and one base utility box: paint price group 1 • Two lay-in horizontal connecting bars: black paint only 	<ul style="list-style-type: none"> 1 Style number 2 Paint color number for top cap, base trim, and base utility box 3 Options, if selected (see below) ▶ See <i>Surface Materials</i>, page 668.

Options	U.S. Price	Required to Specify
Surface Materials <ul style="list-style-type: none"> • Paint price group 1 • Paint price group 2 • Paint price group 3 	<ul style="list-style-type: none"> No cost +\$16 +\$34 	<ul style="list-style-type: none"> Specify paint color number. Specify paint color number. Specify paint color number.
Change-of-Height Top Cap <ul style="list-style-type: none"> • Change-of-height at one end of top cap, slim • Change-of-height at one end of top cap, cable management • Change-of-height at both ends of top cap on 36" - 48"W packages, slim • Change-of-height at both ends of top cap on 36" - 48"W packages, cable management • Change-of-height at both ends of top cap on 36" - 48"W packages, 1 end slim and one end cable management 	<ul style="list-style-type: none"> +\$ 7 +\$ 7 +\$ 7 +\$ 7 +\$ 7 	<ul style="list-style-type: none"> Specify with <i>change-of-height, one end slim.</i> Specify with <i>change-of-height, one end cable management.</i> Specify with <i>change-of-height, both ends slim.</i> Specify with <i>change-of-height, both ends cable management.</i> Specify with <i>change-of-height, one end slim, one end cable management.</i>

Specification Information		
Width	Style Number	U.S. Base Price
30"	TS730SSUF	\$792
36"	TS736SSUF	\$841
42"	TS742SSUF	\$911
48"	TS748SSUF	\$993
:	:	:



For Canadian Pricing
Multiply U.S. Price by the Canadian price factor.
▶ See page 1 for details.

Floor-Access Lay-In Utility Packages—Oval Trim

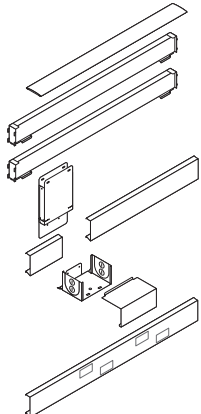

Tip: 30"W lay-in utility package with floor-access is only available with change-of-height shortened top cap at one end.

Tip: Order multipurpose power infeed separately.
▶ Page 492

Standard Includes		Required to Specify
▶ Need help? Product details, page 168	<ul style="list-style-type: none"> One top cap, one standard base trim, one modified base trim, and one base utility box: paint price group 1 Two lay-in horizontal connecting bars: black paint only 	1 Style number 2 Paint color number for top cap, base trim, and base utility box 3 Options, if selected (see below) ▶ See <i>Surface Materials</i> , page 668.

Options	U.S. Price	Required to Specify
Surface Materials	<ul style="list-style-type: none"> Paint price group 1: No cost Paint price group 2: +\$16 Paint price group 3: +\$34 	Specify paint color number.
Change-of-Height Shortened Top Cap	<ul style="list-style-type: none"> Change-of-height cable routing at one end of top cap: +\$ 7 Change-of-height cable routing at both ends of top cap on 36", 42", and 48"W packages: +\$ 7 	Specify with <i>change-of-height</i> , one end.

Specification Information		
Width	Style Number	U.S. Base Price
30"	TS730SUF	\$ 933
36"	TS736SUF	\$ 984
42"	TS742SUF	\$1068
48"	TS748SUF	\$1172
:	:	:

 **For Canadian Pricing**
 Multiply U.S. Price by the Canadian price factor.
 ▶ See page 1 for details.

Standard Change-of-Height Trims—Square Trim

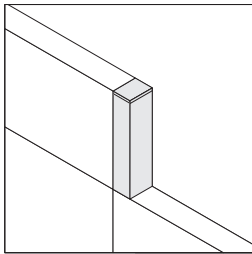
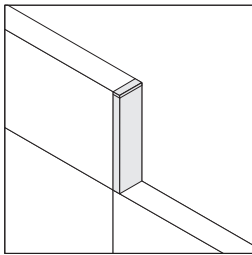

Tip: Cable-routing trim provides cable routing capacity.
▶ See page 164 for capacities.

Tip: Remember to specify the change-of-height top cap option for the lower panels in change-of-height configurations when using either type of change-of-height trim.
▶ Page 96

Tip: For further information about fabric direction,
▶ Page 674.

Standard Includes		Required to Specify
▶ Need help? Product details, page 96	<ul style="list-style-type: none"> Change-of-height trim: paint price group 1 One change-of-height junction cap: must specify corner application or in-line application 	<ol style="list-style-type: none"> Style number Junction cap application Paint color number for trim Paint color number for junction cap Options, if selected (see below) <p>▶ See <i>Surface Materials</i>, page 668.</p>

Options	U.S. Price	Required to Specify
Surface Materials		
<ul style="list-style-type: none"> Change-of-height trim Paint price group 1 Paint price group 2 Paint price group 3 	<ul style="list-style-type: none"> No cost +\$ 16 +\$ 34 	<ul style="list-style-type: none"> Specify paint color number. Specify paint color number. Specify paint color number.
<ul style="list-style-type: none"> Fabric price group 1, 2, 3, 4, 5, or COM Fabric direction –Horizontal application (standard) –Vertical application 	<ul style="list-style-type: none"> +\$ 80 No cost No cost 	<ul style="list-style-type: none"> Specify fabric color number for trim. Specify <i>with horizontal application</i>. Specify <i>with vertical application</i>.

Specification Information		
Application	Style Number	U.S. Base Price
⋮	⋮	⋮

Painted Junction Cap

Slim Profile

12"	TS712SCHS	\$109
18"	TS718SCHS	\$117
24"	TS724SCHS	\$126
30"	TS730SCHS	\$140
36"	TS736SCHS	\$154

Cable-Routing Capability

12"	TS712SCH	\$109
18"	TS718SCH	\$117
24"	TS724SCH	\$126
30"	TS730SCH	\$140
36"	TS736SCH	\$154



For Canadian Pricing
Multiply U.S. Price by the Canadian price factor.
▶ See page 1 for details.

Standard Change-of-Height Trims—Oval Trim

Standard Change-of-Height
Trims—Oval Trim

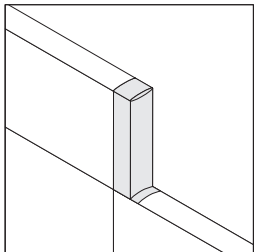
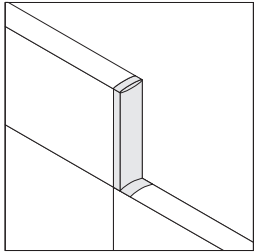

Tip: Cable-routing trim provides cable routing capacity.
▶ See page 164 for capacities.

Tip: Remember to specify the shortened top cap option for the lower panels in change-of-height configurations when using either type of change-of-height trim.
▶ Page 96

Tip: For further information about fabric direction,
▶ Page 674.

Standard Includes		Required to Specify
▶ Need help? Product details, page 96	<ul style="list-style-type: none"> Change-of-height trim: paint price group 1 One change-of-height junction cap: must specify corner application or in-line application One bottom filler: plastic 	<ol style="list-style-type: none"> Style number Junction cap application Paint color number for trim Plastic color number for junction caps and bottom filler Options, if selected (see below) ▶ See <i>Surface Materials</i> , page 668.

Options	U.S. Price	Required to Specify
Surface Materials		
<ul style="list-style-type: none"> Change-of-height trim Paint price group 1 Paint price group 2 Paint price group 3 	No cost +\$16 +\$34	Specify paint color number. Specify paint color number. Specify paint color number.
<ul style="list-style-type: none"> Fabric price group 1, 2, 3, 4, 5, or COM Fabric direction –Horizontal application (standard) –Vertical application 	+\$80 No cost No cost	Specify fabric color number for trim. Specify with <i>horizontal application</i> . Specify with <i>vertical application</i> .

Specification Information

Application	Style Number	U.S. Base Price
.....

Painted Junction Cap

Slim Profile

12"	TS712CHS	\$130
18"	TS718CHS	\$140
24"	TS724CHS	\$149
30"	TS730CHS	\$165
36"	TS736CHS	\$183

Cable-Routing Capability

12"	TS712CH	\$130
18"	TS718CH	\$140
24"	TS724CH	\$149
30"	TS730CH	\$165
36"	TS736CH	\$183

 **For Canadian Pricing**
Multiply U.S. Price by the Canadian price factor.
▶ See page 1 for details.

Panels—Square and Oval Trim

Stacking Change-of-Height Trims—Square and Oval Trims

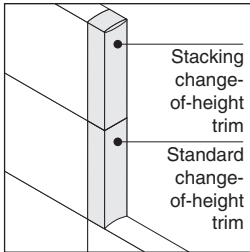
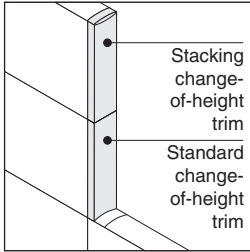

Tip: Stacking change-of-height trim is only used on the second tier in a change-of-height configuration.

Tip: Change-of-height junction cap is not included with stacking change-of-height trim. Use the change-of-height junction cap from the standard change-of-height trim you are stacking on.

Tip: Cable-routing trim provides cable routing capacity.

Tip: For further information about fabric direction, ▶ Page 674.

Tip: Stacking change-of-height trim works with square and oval top trim styles but not with thin top trim style.

Standard Includes	Required to Specify
<ul style="list-style-type: none"> ▶ Need help? Product details, page 96 • Change-of-height trim: paint price group 1 • Stacking trim aligner: black plastic only 	<ul style="list-style-type: none"> 1 Style number 2 Paint color number for trim 3 Options, if selected (see below) ▶ See <i>Surface Materials</i>, page 668.

Surface Materials	Options	U.S. Price	Required to Specify
	Change-of-height trim <ul style="list-style-type: none"> • Paint price group 1 • Paint price group 2 • Paint price group 3 	No cost +\$16 +\$34	Specify paint color number. Specify paint color number. Specify paint color number.
	For use on steel trim only <ul style="list-style-type: none"> • Fabric price group 1, 2, 3, 4, 5, or COM • Fabric direction <ul style="list-style-type: none"> –Horizontal application (standard) –Vertical application 	+\$80 No cost No cost	Specify fabric color number for trim. Specify <i>with horizontal application</i> . Specify <i>with vertical application</i> .

Specification Information		
Corresponding Panel Height	Style Number	U.S. Base Price

Steel Trim

Stacking Change-of-Height Trim with Slim Profile		
12"	TS712CHST	\$ 95
18"	TS718CHST	\$106
24"	TS724CHST	\$109

Stacking Change-of-Height Trim with Cable Routing Capability		
12"	TS712CHT	\$ 95
18"	TS718CHT	\$106
24"	TS724CHT	\$109



For Canadian Pricing
 Multiply U.S. Price by the Canadian price factor.
 ▶ See page 1 for details.

Base Horizontal Frame Packages—Square Trim

For Panel Buildups

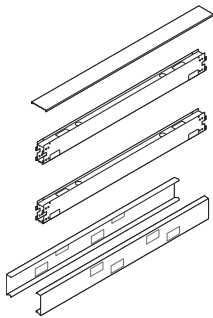

Tip: You must order vertical junctions separately to complete your frame.

▶ Page 402

Tip: Specify omit top cap when adding a frameless glass screen to a panel or when ordering spanning top caps.

Tip: Remember to specify an optional change-of-height top cap on any panel in a change-of-height configuration.

Exception: The tallest panel in the configuration never needs a change-of-height top cap.

Tip: Remember to omit base trim(s) when using skins to the floor or when using an open base trim conversion kit.

Tip: Base cable tray cannot be used if omit base trim is selected for one or both sides of panel.

Tip: Remember to order skins to complete the panel.

Tip: Omit standard base trim and specify separate hardware base trim when accessing hardware power in the base.

Standard Includes		Required to Specify
▶ Need help? Product details, page 104	<ul style="list-style-type: none"> Standard length top cap: color default determined by base trim paint color Base trim with knockouts: paint price group 1 Two horizontal connecting bars: black paint only 	<ol style="list-style-type: none"> Style number Paint color number for trim Options, if selected (see below) <p>▶ See <i>Surface Materials</i>, page 668.</p>

	Options	U.S. Price	Required to Specify
Surface Materials	<ul style="list-style-type: none"> Paint price group 1 Paint price group 2 Paint price group 3 	<ul style="list-style-type: none"> No cost +\$16 +\$34 	<ul style="list-style-type: none"> Specify paint color number. Specify paint color number. Specify paint color number.
	Top cap		
	<ul style="list-style-type: none"> Omit top cap 	No cost	Specify omit top cap.
Change-of-Height Top Cap	<ul style="list-style-type: none"> Change-of-height at one end of top cap, slim Change-of-height at one end of top cap, cable management Change-of-height at both ends of top cap on 36"W and wider packages, slim Change-of-height at both ends of top cap on 36"W and wider packages, cable management Change-of-height at both ends of top cap on 36"W and wider packages, 1 end slim and one end cable management 	<ul style="list-style-type: none"> +\$ 7 +\$ 7 +\$ 7 +\$ 7 +\$ 7 	<ul style="list-style-type: none"> Specify with change-of-height, one end slim. Specify with change-of-height, one end cable management. Specify with change-of-height, both ends slim. Specify with change-of-height, both ends cable management. Specify with change-of-height one end slim, one end cable management.
Base Trim	<ul style="list-style-type: none"> Knockouts one side, plain one side (24"-72"W only) Plain both sides, (24"-72"W only) Omit one side, knockouts one side, 18"W to 36"W Omit one side, knockouts one side, 42"W to 48"W Omit one side, knockouts one side, 60"W to 72"W Omit one side, plain one side, 18"W to 36"W Omit one side, plain one side, 42"W to 48"W Omit one side, plain one side, 60"W to 72"W Omit both sides, 18"W to 36"W Omit both sides, 42"W to 48"W Omit both sides, 60"W to 72"W 	<ul style="list-style-type: none"> No cost No cost -\$ 3 -\$ 4 -\$ 5 -\$ 3 -\$ 4 -\$ 5 -\$ 6 -\$ 8 -\$10 	<ul style="list-style-type: none"> Specify with knockouts one side, plain one side. Specify with plain both sides. Specify with omit one side, knockouts one side. Specify with omit one side, knockouts one side. Specify with omit one side, knockouts one side. Specify with omit one side, plain one side. Specify with omit one side, plain one side. Specify with omit one side, plain one side. Specify with omit both sides. Specify with omit both sides. Specify with omit both sides.
Cable Tray	<ul style="list-style-type: none"> Cable tray 	No cost	Specify with cable tray.
Base Cable Tray	<ul style="list-style-type: none"> Base cable tray 	+\$ 5	Specify with base cable tray.



For Canadian Pricing

Multiply U.S. Price by the Canadian price factor.

▶ See page 1 for details.

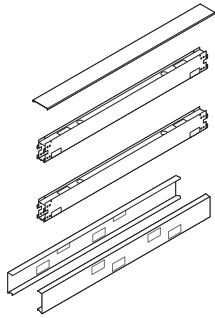

Specification Information

Width	Style Number	U.S. Base Price
18"	TS718SHF	\$138
24"	TS724SHF	\$143
30"	TS730SHF	\$155
36"	TS736SHF	\$165
42"	TS742SHF	\$190
48"	TS748SHF	\$199
60"	TS760SHF	\$255
72"	TS772SHF	\$349
:	:	:

 **For Canadian Pricing**
Multiply U.S. Price by the
Canadian price factor.
▶ See page 1 for details.

Base Horizontal Frame Packages—Oval Trim

For Panel Buildups

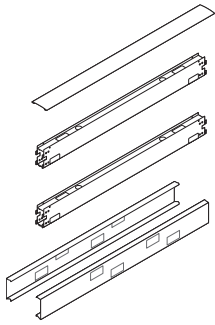

Tip: You must order vertical junctions separately to complete your frame.

▶ Page 403

Tip: Remember to specify an optional shortened change-of-height top cap on any panel in a change-of-height configuration.

Exception: The tallest panel in the configuration never needs a shortened change-of-height top cap.

Tip: Remember to omit base trim(s) when using skins to the floor or when using an open base trim conversion kit.

Tip: Base cable tray cannot be used if omit base trim is selected for one or both sides of panel.

Tip: Remember to order skins to complete the panel.
▶ Page 436

Tip: Omit standard base trim and specify separate hardwire base trim when accessing hardwire power in the base.

Standard Includes		Required to Specify
▶ Need help? Product details, page 104	<ul style="list-style-type: none"> Standard length top cap: color default determined by base trim paint color Base trim with knockouts: paint price group 1 Two horizontal connecting bars: black paint only 	1 Style number 2 Paint color number for trim 3 Options, if selected (see below) ▶ See <i>Surface Materials</i> , page 668.

Options	U.S. Price	Required to Specify
Surface Materials	<ul style="list-style-type: none"> Paint price group 1: No cost Paint price group 2: +\$16 Paint price group 3: +\$34 	Specify paint color number.
Change-of-Height Shortened Top Cap	<ul style="list-style-type: none"> Change-of-height at one end of top cap: +\$ 7 Change-of-height at both ends of top cap on 36"W and wider frame packages: +\$ 7 	Specify with change-of-height, one end. Specify with change-of-height, both ends.
Base Trim	<ul style="list-style-type: none"> Knockouts one side, plain one side (24"-72"W only): No cost Plain both sides, (24"-72"W only): No cost Omit one side, knockouts one side, 18"W to 36"W: -\$ 3 Omit one side, knockouts one side, 42"W to 48"W: -\$ 4 Omit one side, knockouts one side, 60"W to 72"W: -\$ 5 Omit one side, plain one side, 18"W to 36"W: -\$ 3 Omit one side, plain one side, 42"W to 48"W: -\$ 4 Omit one side, plain one side, 60"W to 72"W: -\$ 5 Omit both sides, 18"W to 36"W: -\$ 6 Omit both sides, 42"W to 48"W: -\$ 8 Omit both sides, 60"W to 72"W: -\$10 	Specify with knockouts one side, plain one side. Specify with plain both sides. Specify with omit one side, knockouts one side. Specify with omit one side, knockouts one side. Specify with omit one side, knockouts one side. Specify with omit one side, plain one side. Specify with omit one side, plain one side. Specify with omit one side, plain one side. Specify with omit both sides. Specify with omit both sides.
Cable Tray	<ul style="list-style-type: none"> Cable tray: No cost 	Specify with cable tray.
Base Cable Tray	<ul style="list-style-type: none"> Base cable tray: +\$ 5 	Specify with base cable tray.

Specification Information		
Width	Style Number	U.S. Base Price
18"	TS718HF	\$158
24"	TS724HF	\$166
30"	TS730HF	\$186
36"	TS736HF	\$194
42"	TS742HF	\$220
48"	TS748HF	\$235
60"	TS760HF	\$295
72"	TS772HF	\$404



For Canadian Pricing
Multiply U.S. Price by the Canadian price factor.
▶ See page 1 for details.

Stacking Horizontal Frame Packages

For Panel Buildups

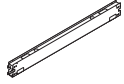

Tip: You must order vertical stacking junctions separately to complete your frame.

▶ Page 413

Tip: Top cap is not included. Use the top cap from the base panel you are stacking on.

Tip: If stacking a window kit, stacking horizontal frame package is not needed.

Tip: Remember to order skins to complete the panel.

▶ Page 436

Standard Includes	Required to Specify
▶ Need help? Product details, page 106 • One horizontal connecting bar: black paint only	Style number

Specification Information		
Width	Style Number	U.S. Price
18"	TS718HFS	\$26
24"	TS724HFS	\$31
30"	TS730HFS	\$32
36"	TS736HFS	\$34
42"	TS742HFS	\$37
48"	TS748HFS	\$44
60"	TS760HFS	\$51
72"	TS772HFS	\$75
:	:	:

 **For Canadian Pricing**
 Multiply U.S. Price by the Canadian price factor.
 ▶ See page 1 for details.

Spanning Top Caps—Square Trim

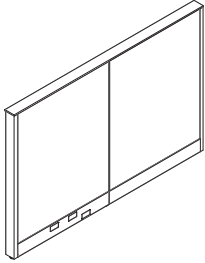

Tip: In-line spanning top cap lightseals should be specified for each in-line joint top cap is spanning across.

▶ Page 477

Standard Includes	Required to Specify
<ul style="list-style-type: none"> ▶ Need help? Product details, page 105 • Top cap: paint group 1 	<ul style="list-style-type: none"> 1 Style number 2 Paint color number for top cap 3 Options, if selected (see below) ▶ See <i>Surface Materials</i>, page 668.

Options	U.S. Price	Required to Specify
Change-of-Height Shortened Top Cap <ul style="list-style-type: none"> • Change-of-height at one end of top cap, slim +\$7 • Change-of-height at one end of top cap, cable management +\$7 • Change-of-height at both ends of top cap, slim +\$7 • Change-of-height at both ends of top cap, cable management +\$7 • Change-of-height at both ends of top cap, one end slim and one end cable management +\$7 		<ul style="list-style-type: none"> Specify with <i>change-of-height, one end slim.</i> Specify with <i>change-of-height, one end cable management.</i> Specify with <i>change-of-height, both ends slim.</i> Specify with <i>change-of-height, both ends cable management.</i> Specify with <i>change-of-height, one end slim, one end cable management.</i>

Specification Information		
Width	Style Number	U.S. Base Price

Painted Top Caps		
36"	TS736STC	\$ 34
42"	TS742STC	\$ 44
48"	TS748STC	\$ 50
60"	TS760STC	\$ 57
72"	TS772STC	\$ 70
78"	TS778STC	\$ 80
84"	TS784STC	\$ 95
90"	TS790STC	\$109
96"	TS796STC	\$122



For Canadian Pricing
 Multiply U.S. Price by the Canadian price factor.
 ▶ See page 1 for details.

Frameless Glass Screens—Square Trim

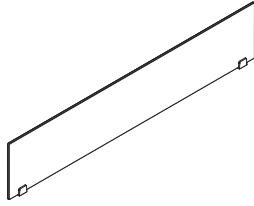

Tip: These screens are only available for use on panels with square trim.

Tip: Remember to specify in-line top cap lightseals if frameless glass screen is spanning two or more panels.

▶ Page 477

Standard Includes		Required to Specify
▶ Need help? Product details, page 108	<ul style="list-style-type: none"> Glass screen, 6500 Clear Glass Two brackets – 24"-84" wide: paint Three brackets – 90"-96" wide: paint Two supports Square profile top cap with holes: paint 	<ol style="list-style-type: none"> Style Number Paint color number for brackets Paint color number for top cap Options, if selected (see below) <p>▶ See <i>Surface Materials</i>, page 668.</p>

Options	U.S. Price	Required to Specify
Surface Materials Top cap <ul style="list-style-type: none"> Paint price group 1 Paint price group 2 Paint price group 3 	No cost +\$16 +\$34	Specify paint color number. Specify paint color number. Specify paint color number.
Change-of-Height Top Cap <ul style="list-style-type: none"> Change-of-height at one end of top cap, slim 	+ \$ 7	Specify with <i>change-of-height, one end slim</i> .
Glass Screen <ul style="list-style-type: none"> Omit glass screen Frosted glass 	Prices below Prices below	Specify with <i>omit screen</i> . Specify with <i>6530 Frosted Tempered Glass</i> .

Specification Information				
Width	Style Number	U.S. Base Price	Options (Add \$ to Base Price)	
			Omit Glass	Frosted Glass
24"	TS71224SFG	\$ 704	-\$112	+\$ 86
30"	TS71230SFG	\$ 752	-\$126	+\$113
36"	TS71236SFG	\$ 812	-\$135	+\$173
42"	TS71242SFG	\$ 868	-\$141	+\$255
48"	TS71248SFG	\$ 916	-\$154	+\$284
60"	TS71260SFG	\$1056	-\$168	+\$365
72"	TS71272SFG	\$1178	-\$182	+\$438
78"	TS71278SFG	\$1311	-\$198	+\$462
84"	TS71284SFG	\$1444	-\$210	+\$476
90"	TS71290SFG	\$1577	-\$225	+\$526
96"	TS71296SFG	\$1707	-\$239	+\$552

 **For Canadian Pricing**
 Multiply U.S. Price by the Canadian price factor.
 ▶ See page 1 for details.

Panels—Square and Oval Trim



Specifying Shared Components and Wiring and Cabling

(Thin, Square, and Oval)

Shared Components

Fabric Covered Panel Skins	436
Fabric Covered Panel Skins To The Floor	438
Fabric Covered Panel Skins Big Open Base	440
Steel Panel Skins	442
Steel To The Floor Skins	444
Markerboard Surfaces for Steel Skins	447
Markerboard Skins	448
Markerboard To The Floor Skins	449
Slatwall Skins and Slatwall Skin Brace Packages	450
Laminate Skins	452
Laminate To The Floor Skins	453
Wood Skins	454
Wood To The Floor Skins	456
Wood Skin Sets	458
Wood To The Floor Skin Sets	462
Back Painted Glass Skins	466
Back Painted Glass To The Floor Skins	468
Steel Technology Skins	470
Slatwall Technology Skins	472
Markerboard Technology Skins	473
Technology Skin Cover and Fillers	474
Glass Windows	475
Single-Pane Glass Window Kits for Use with Custom Glass	476
Spanning Window In-Line Support and In-Line Spanning Top Cap Lightseal	477
Sliding Panel Doors	478
Hardwire Base Trim	479
Panel and Beam Foot	480

Wiring and Cabling **481**

Fabric Covered Panel Skins

For Panel Buildups

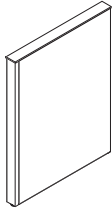

Tip: 72"W fabric-covered panel skins accommodate fabric in the horizontal direction only.

Tip: For further information about fabric direction, see page 674.

Tip: 18"H, 30"H, and 42"H skins only work on junctions manufactured on or after October 10, 2011.

Standard Includes	Required to Specify
<ul style="list-style-type: none"> ▶ Need help? Product details, page 118 Tackable acoustical panel skin, fabric direction with horizontal application, if selected: fabric price group 1 Performance tackable acoustical panel skin, fabric direction with horizontal application, if selected: fabric price group 1 	<ul style="list-style-type: none"> 1 Style number 2 Paint color number for skin surface. 3 Options, if selected (see below) ▶ See <i>Surface Materials</i>, page 668.

Options	U.S. Price			Required to Specify
Surface Materials	12"H and 18"H	24"H and 30"H	36"H to 60"H	
• Fabric price group A	-\$ 3	-\$ 4	-\$ 5	Specify fabric color number.
• Fabric price group 1	No cost	No cost	No cost	Specify fabric color number.
• Fabric price group 2	+\$ 21	+\$ 32	+\$ 39	Specify fabric color number.
• Fabric price group 3	+\$ 39	+\$ 55	+\$ 72	Specify fabric color number.
• Fabric price group 4	+\$ 57	+\$ 81	+\$112	Specify fabric color number.
• Fabric price group 5	+\$ 87	+\$129	+\$174	Specify fabric color number.
• Fabric price group 6	+\$120	+\$172	+\$240	Specify fabric color number.
• Fabric price group 7	+\$155	+\$221	+\$304	Specify fabric color number.
• Fabric price group COM	+\$ 23	+\$ 23	+\$ 23	Specify fabric color number.

Fabric direction on 18"W to 60"W panels

- Vertical application No cost Specify with vertical application.

Specification Information											
12"H			18"H			24"H			30"H		
Width	Style Number	U.S. Base Price	Style Number	U.S. Base Price	Style Number	U.S. Base Price	Style Number	U.S. Base Price			

Tackable Acoustical Skins

18"	TS71218TK	\$113	TS71818TK	\$140	TS72418TK	\$154	TS73018TK	\$199
24"	TS71224TK	\$124	TS71824TK	\$153	TS72424TK	\$169	TS73024TK	\$216
30"	TS71230TK	\$134	TS71830TK	\$164	TS72430TK	\$182	TS73030TK	\$231
36"	TS71236TK	\$140	TS71836TK	\$171	TS72436TK	\$190	TS73036TK	\$251
42"	TS71242TK	\$147	TS71842TK	\$183	TS72442TK	\$202	TS73042TK	\$271
48"	TS71248TK	\$159	TS71848TK	\$194	TS72448TK	\$217	TS73048TK	\$310
60"	TS71260TK	\$183	TS71860TK	\$220	TS72460TK	\$250	TS73060TK	\$351
72"	TS71272TK	\$201	TS71872TK	\$252	TS72472TK	\$278	TS73072TK	\$389

Performance Tackable Acoustical Skins

18"	TS71218TA	\$125	TS71818TA	\$147	TS72418TA	\$167	TS73018TA	\$210
24"	TS71224TA	\$134	TS71824TA	\$158	TS72424TA	\$182	TS73024TA	\$228
30"	TS71230TA	\$142	TS71830TA	\$168	TS72430TA	\$194	TS73030TA	\$246
36"	TS71236TA	\$153	TS71836TA	\$178	TS72436TA	\$204	TS73036TA	\$262
42"	TS71242TA	\$162	TS71842TA	\$187	TS72442TA	\$216	TS73042TA	\$278
48"	TS71248TA	\$174	TS71848TA	\$208	TS72448TA	\$238	TS73048TA	\$319
60"	TS71260TA	\$194	TS71860TA	\$231	TS72460TA	\$271	TS73060TA	\$365
72"	TS71272TA	\$215	TS71872TA	\$258	TS72472TA	\$303	TS73072TA	\$403



For Canadian Pricing

Multiply U.S. Price by the Canadian price factor.

▶ See page 1 for details.

▶ **Specification Information, continued on next page**

► Specification Information, continued from previous page

Specification Information											
36"H			42"H			48"H			60"H		
Width	Style Number	U.S. Base Price	Style Number	U.S. Base Price	Style Number	U.S. Base Price	Style Number	U.S. Base Price			

Tackable Acoustical Skins

18"	TS73618TK	\$227	TS74218TK	\$232	TS74818TK	\$242	TS76018TK	\$292
24"	TS73624TK	\$247	TS74224TK	\$251	TS74824TK	\$256	TS76024TK	\$311
30"	TS73630TK	\$263	TS74230TK	\$266	TS74830TK	\$274	TS76030TK	\$327
36"	TS73636TK	\$281	TS74236TK	\$290	TS74836TK	\$295	TS76036TK	\$346
42"	TS73642TK	\$311	TS74242TK	\$313	TS74842TK	\$323	TS76042TK	\$372
48"	TS73648TK	\$361	TS74248TK	\$365	TS74848TK	\$374	TS76048TK	\$425
60"	TS73660TK	\$416	TS74260TK	\$423	TS74860TK	\$434	TS76060TK	\$477
72"	TS73672TK	\$458	TS74272TK	\$464	TS74872TK	\$477	TS76072TK	\$519

Performance Tackable Acoustical Skins

18"	TS73618TA	\$255	TS74218TA	\$262	TS74818TA	\$266	TS76018TA	\$325
24"	TS73624TA	\$274	TS74224TA	\$280	TS74824TA	\$290	TS76024TA	\$340
30"	TS73630TA	\$294	TS74230TA	\$303	TS74830TA	\$311	TS76030TA	\$362
36"	TS73636TA	\$317	TS74236TA	\$323	TS74836TA	\$330	TS76036TA	\$380
42"	TS73642TA	\$340	TS74242TA	\$349	TS74842TA	\$356	TS76042TA	\$414
48"	TS73648TA	\$399	TS74248TA	\$409	TS74848TA	\$420	TS76048TA	\$475
60"	TS73660TA	\$461	TS74260TA	\$470	TS74860TA	\$483	TS76060TA	\$531
72"	TS73672TA	\$511	TS74272TA	\$519	TS74872TA	\$526	TS76072TA	\$579



For Canadian Pricing

Multiply U.S. Price by the Canadian price factor.

► See page 1 for details.

Fabric Covered Panel Skins To The Floor

For Panel Buildups

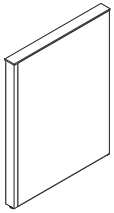

Tip: Remember to omit base trim(s) on a horizontal frame package when using a skin to the floor.

Tip: 48"H fabric covered panel skins to the floor accommodate select fabrics in the vertical direction only.

Tip: 48"H and 60"H fabric covered panel skins accommodate fabric in the vertical direction only.

Tip: 72"W fabric covered panel skins accommodate fabric in the horizontal direction only.

Tip: For further information about fabric direction, see page 674.

Tip: 30"H and 42"H skins only work on junctions manufactured on or after October 10, 2011.

Tip: When specifying skins, the total skin height will be 6" less than the panel height. Skins to the floor are indicated by an F suffix. Plan 6" shorter than panel height, but skins to the floor are taller in actual height to cover the base trim area.

► See Panel Buildups, page 18, for more information.



For Canadian Pricing
Multiply U.S. Price by the Canadian price factor.

► See page 1 for details.

Standard Includes	Required to Specify
-------------------	---------------------

- | | | |
|----------------------------------------------|------------------------------------------------------------------------------------------------------------------------------------|---------------------------------------------------------------------------------------------------------------------------------------------------------------------------------------------------------------|
| ► Need help?
Product details,
page 118 | <ul style="list-style-type: none"> Panel skins, fabric direction application, if selected:
fabric price group 1 | <ul style="list-style-type: none"> 1 Style number 2 Fabric color number for skin surface 3 Options, if selected (see below) <p>► See <i>Surface Materials</i>, page 668.</p> |
|----------------------------------------------|------------------------------------------------------------------------------------------------------------------------------------|---------------------------------------------------------------------------------------------------------------------------------------------------------------------------------------------------------------|

Options	U.S. Price	Required to Specify
---------	------------	---------------------

Surface Materials	Options	U.S. Price		Required to Specify
		24" and 30"H	36" to 60"H	
• Fabric price group A • Fabric price group 1 • Fabric price group 2 • Fabric price group 3 • Fabric price group 4 • Fabric price group 5 • Fabric price group 6 • Fabric price group 7 • Fabric price group COM		-\$ 4	-\$ 5	Specify fabric color number.
		No cost	No cost	Specify fabric color number.
		+\$ 32	+\$ 39	Specify fabric color number.
		+\$ 55	+\$ 72	Specify fabric color number.
		+\$ 81	+\$112	Specify fabric color number.
		+\$129	+\$174	Specify fabric color number.
		+\$172	+\$240	Specify fabric color number.
		+\$221	+\$304	Specify fabric color number.
	+\$ 23	+\$ 23	Specify fabric color number.	

Fabric direction on 18"W to 60"W skins

- | | | |
|------------------------|---------|------------------------------------|
| • Vertical application | No cost | Specify with vertical application. |
|------------------------|---------|------------------------------------|

Specification Information

24"H			30"H			36"H		
• Width	• Style Number	• U.S. Base Price	• Style Number	• U.S. Base Price	• Style Number	• U.S. Base Price		
.....		

Tackable Acoustical Skins



18"	TS72418TKF	\$167	TS73018TKF	\$215	TS73618TKF	\$246
24"	TS72424TKF	\$183	TS73024TKF	\$228	TS73624TKF	\$259
30"	TS72430TKF	\$194	TS73030TKF	\$250	TS73630TKF	\$275
36"	TS72436TKF	\$204	TS73036TKF	\$262	TS73636TKF	\$295
42"	TS72442TKF	\$216	TS73042TKF	\$286	TS73642TKF	\$325
48"	TS72448TKF	\$231	TS73048TKF	\$323	TS73648TKF	\$373
60"	TS72460TKF	\$262	TS73060TKF	\$365	TS73660TKF	\$428
72"	TS72472TKF	\$293	TS73072TKF	\$403	TS73672TKF	\$471

Performance Tackable Acoustical Skins

18"	TS72418TAF	\$174	TS73018TAF	\$234	TS73618TAF	\$266
24"	TS72424TAF	\$190	TS73024TAF	\$256	TS73624TAF	\$290
30"	TS72430TAF	\$203	TS73030TAF	\$270	TS73630TAF	\$308
36"	TS72436TAF	\$214	TS73036TAF	\$290	TS73636TAF	\$331
42"	TS72442TAF	\$221	TS73042TAF	\$311	TS73642TAF	\$355
48"	TS72448TAF	\$246	TS73048TAF	\$355	TS73648TAF	\$415
60"	TS72460TAF	\$277	TS73060TAF	\$403	TS73660TAF	\$473
72"	TS72472TAF	\$305	TS73072TAF	\$448	TS73672TAF	\$521

► **Specification Information, continued on next page**

► Specification Information, continued from previous page

Specification Information						
42"H			48"H		60"H	
						
Width	Style Number	U.S. Base Price	Style Number	U.S. Base Price	Style Number	U.S. Base Price

Shared Components

Tackable Acoustical Skins

18"	TS74218TKF	\$250	TS74818TKF	\$255	TS76018TKF	\$305
24"	TS74224TKF	\$263	TS74824TKF	\$268	TS76024TKF	\$325
30"	TS74230TKF	\$279	TS74830TKF	\$291	TS76030TKF	\$339
36"	TS74236TKF	\$303	TS74836TKF	\$310	TS76036TKF	\$359
42"	TS74242TKF	\$327	TS74842TKF	\$336	TS76042TKF	\$386
48"	TS74248TKF	\$378	TS74848TKF	\$388	TS76048TKF	\$441
60"	TS74260TKF	\$435	TS74860TKF	\$446	TS76060TKF	\$493
72"	TS74272TKF	\$491	TS74872TKF	\$493		

Performance Tackable Acoustical Skins

18"	TS74218TAF	\$274	TS74818TAF	\$280	TS76018TAF	\$338
24"	TS74224TAF	\$294	TS74824TAF	\$304	TS76024TAF	\$355
30"	TS74230TAF	\$315	TS74830TAF	\$323	TS76030TAF	\$376
36"	TS74236TAF	\$334	TS74836TAF	\$340	TS76036TAF	\$393
42"	TS74242TAF	\$362	TS74842TAF	\$370	TS76042TAF	\$428
48"	TS74248TAF	\$423	TS74848TAF	\$433	TS76048TAF	\$488
60"	TS74260TAF	\$483	TS74860TAF	\$495	TS76060TAF	\$549
72"	TS74272TAF	\$528	TS74872TAF	\$546		



For Canadian Pricing
Multiply U.S. Price by the
Canadian price factor.
► See page 1 for details.

Fabric Covered Panel Skins Big Open Base

For Panel Buildups

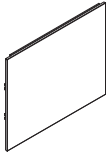

Tip: 72"W fabric-covered panel skins accommodate fabric in the horizontal direction only.

Tip: For further information about fabric direction, see page 674.

Standard Includes	Required to Specify
-------------------	---------------------

- | | | |
|------------------------------------------------------------------------------------------|----------------------------------------------------------------------------------------------------------------------------------------------------------------------------------------------------|-----------------------------------------------------------------------------------------------------------------------------------------------------------------------------------------------------------------|
| <ul style="list-style-type: none"> ▶ Need help? Product details, page 118 | <ul style="list-style-type: none"> • 19³/₁₆"H tackable acoustical panel skin, fabric direction with horizontal application, if selected: fabric price group 1 | <ul style="list-style-type: none"> 1 Style number 2 Paint color number for skin surface. 3 Options, if selected (see below) ▶ See <i>Surface Materials</i>, page 668. |
|------------------------------------------------------------------------------------------|----------------------------------------------------------------------------------------------------------------------------------------------------------------------------------------------------|-----------------------------------------------------------------------------------------------------------------------------------------------------------------------------------------------------------------|

Options	U.S. Price	Required to Specify
---------	------------	---------------------

Surface Materials	<ul style="list-style-type: none"> • Fabric price group A - \$ 3 • Fabric price group 1 No cost • Fabric price group 2 + \$ 21 • Fabric price group 3 + \$ 39 • Fabric price group 4 + \$ 57 • Fabric price group 5 + \$ 87 • Fabric price group 6 + \$120 • Fabric price group 7 + \$155 • Fabric price group COM + \$ 23 	<ul style="list-style-type: none"> Specify fabric color number. Specify fabric color number. Specify fabric color number. Specify fabric color number. Specify fabric color number. Specify fabric color number. Specify fabric color number. Specify fabric color number.
--------------------------	-------------------------------------------------------------------------------------------------------------------------------------------------------------------------------------------------------------------------------------------------------------------------------------------------------------------------------------------------------------------------------------------------------------------	----------------------------------------------------------------------------------------------------------------------------------------------------------------------------------------------------------------------------------------------------------------------------------------------------------------------------------------------------------

Fabric direction on 18"W to 60"W panels

- | | | |
|--------------------------------------------------------------------------|-----------------------------------------------------------|--------------------------------------------------------------------------------------|
| <ul style="list-style-type: none"> • Vertical application | <ul style="list-style-type: none"> No cost | <ul style="list-style-type: none"> Specify with vertical application. |
|--------------------------------------------------------------------------|-----------------------------------------------------------|--------------------------------------------------------------------------------------|

Specification Information		
Width	Style Number	U.S. Base Price

18"	TS718TKBOB	\$140
24"	TS724TKBOB	\$153
30"	TS730TKBOB	\$164
36"	TS736TKBOB	\$171
42"	TS742TKBOB	\$183
48"	TS748TKBOB	\$194
60"	TS760TKBOB	\$220
72"	TS772TKBOB	\$252
:	:	:



For Canadian Pricing

Multiply U.S. Price by the Canadian price factor.

▶ See page 1 for details.

Steel Panel Skins

For Panel Buildups



Tip: Steel skins cannot accommodate power receptacles or communication outlets. Use the base or fabric skin for power access.

Tip: Horizontal beam and the back of the opposite skin is visible through a perforated skin.

Tip: 18"H and 30"H skins only work on junctions manufactured on or after October 10, 2011.

Tip: Data and modular receptacle cutouts are available on 24"H steel skins only.

Tip: Data cutout can be placed on the left or the right side of a steel beam skin. Data cutouts cannot be placed on both left and right side of steel beam skins.

Tip: Data cutout is an option under receptacle location. Specify data cutout location under the appropriate receptacle selection. Data cutout price is added to the receptacle cutout price.

Tip: On 24"W and 30"W steel skins, hardwire receptacle cutout option will always be with a centered hardwire cutout.

Tip: On 36"W and wider steel skins, hardwire receptacle cutout option will always come with a left and a right hardwire cutout.



Tip: No data or modular receptacle cutouts are available on 18"W steel skins.



Tip: Data or modular receptacle cutouts are NOT available on perforated or ribbed steel skins.

Standard Includes		Required to Specify		
<ul style="list-style-type: none"> ▶ Need help? Product details, page 120 	<ul style="list-style-type: none"> • Steel panel skin: paint price group 1 	<ul style="list-style-type: none"> 1 Style number 2 Paint color number for skin surface 3 Options, if selected (see below) ▶ See <i>Surface Materials</i>, page 668. 		
Options	U.S. Price	Required to Specify		
Surface Materials	12"H-24"H	30"H	36"H	
<ul style="list-style-type: none"> • Paint price group 1 • Paint price group 2 • Paint price group 3 • Ribbed steel on 12"H to 24"H panel skins only • Perforated steel on 12"H to 24"H panel skins only 	No cost +\$35 +\$59 +\$33 Prices below	No cost +\$35 +\$59 N.A.	No cost +\$ 69 +\$114 N.A.	Specify paint color number. Specify paint color number. Specify paint color number. Specify with ribbed steel. Specify with perforated steel.
Data Cutout Only (24"H only)	24"W-30"W	36"W	42"W-72"W	
<ul style="list-style-type: none"> • Left modular furniture data cutout or left NEMA data cutout • Right modular furniture data cutout or right NEMA data cutout 	N.A. +\$12	N.A. +\$12	+\$ 12 +\$ 12	Specify with left modular furniture data cutout or left NEMA data cutout. Specify with right modular furniture data cutout or right NEMA data cutout.
Modular Receptacle Cutout (24"H only)				
<ul style="list-style-type: none"> • Center receptacle cutout • Center receptacle cutout with right modular furniture data cutout or right NEMA data cutout • Left receptacle cutout • Left receptacle cutout with left modular furniture data cutout or left NEMA data cutout • Right receptacle cutout • Right receptacle cutout with right modular furniture data cutout or right NEMA data cutout • Left and right receptacle cutout • Left and right receptacle cutout with left modular furniture data cutout or left NEMA data cutout • Left and right receptacle cutout with right modular furniture data cutout or right NEMA data cutout 	+\$12 +\$24 N.A. N.A. N.A. N.A. N.A. N.A.	N.A. N.A. N.A. N.A. +\$12 +\$24 +\$24 N.A.	+\$ 12 +\$ 24 +\$ 12 +\$ 24 +\$ 24 +\$ 36 +\$ 36	Specify with center receptacle cutout. Specify with center receptacle cutout and right modular furniture data cutout or right NEMA data cutout. Specify with left receptacle cutout. Specify with left receptacle cutout and left modular furniture data cutout or left NEMA data cutout. Specify with right receptacle cutout. Specify with right receptacle cutout and right modular furniture data cutout or right NEMA data cutout. Specify with left and right receptacle cutout. Specify with left and right receptacle cutout and left modular furniture data cutout or left NEMA data cutout. Specify with left and right receptacle cutout and right modular furniture data cutout or right NEMA data cutout.
Hardwire Power/Data Cutouts (24"H only)				
<ul style="list-style-type: none"> • Hardwired with receptacle cutout • Hardwired with left receptacle cutout and left modular furniture data cutout or left NEMA data cutout • Hardwired with right receptacle cutout and right modular furniture data cutout or right NEMA data cutout 	+\$12 N.A. +\$24	+\$12 N.A. +\$24	+\$ 12 +\$ 24 +\$ 24	Specify with receptacle cutout. Specify with left receptacle cutout and left modular furniture data cutout or left NEMA data cutout. Specify with right receptacle cutout and right modular furniture data cutout or right NEMA data cutout.

 **For Canadian Pricing**
Multiply U.S. Price by the Canadian price factor.
▶ See page 1 for details.

Specification Information

12"H										18"H				24"H			
Width	Style Number	U.S. Base Price	Option (Add \$ to Base Price)	Style Number	U.S. Base Price	Option (Add \$ to Base Price)	Style Number	U.S. Base Price	Option (Add \$ to Base Price)								
			Perforated Steel			Perforated Steel			Perforated Steel								
18"	TS71218HS	\$ 88	+\$ 51	TS71818HS	\$116	+\$ 85	TS72418HS	\$146	+\$ 85								
24"	TS71224HS	\$ 98	+\$ 58	TS71824HS	\$124	+\$101	TS72424HS	\$154	+\$101								
30"	TS71230HS	\$109	+\$ 62	TS71830HS	\$141	+\$107	TS72430HS	\$171	+\$107								
36"	TS71236HS	\$113	+\$ 66	TS71836HS	\$148	+\$111	TS72436HS	\$182	+\$111								
42"	TS71242HS	\$119	+\$ 72	TS71842HS	\$155	+\$117	TS72442HS	\$190	+\$117								
48"	TS71248HS	\$134	+\$ 78	TS71848HS	\$167	+\$130	TS72448HS	\$204	+\$130								
60"	TS71260HS	\$147	+\$ 89	TS71860HS	\$190	+\$143	TS72460HS	\$238	+\$143								
72"	TS71272HS	\$165	+\$106	TS71872HS	\$214	+\$162	TS72472HS	\$263	+\$162								

30"H			36"H	
Width	Style Number	U.S. Base Price	Style Number	U.S. Base Price
				
18"	TS73018HS	\$177	TS73618HS	\$210
24"	TS73024HS	\$191	TS73624HS	\$228
30"	TS73030HS	\$209	TS73630HS	\$251
36"	TS73036HS	\$225	TS73636HS	\$266
42"	TS73042HS	\$239	TS73642HS	\$287
48"	TS73048HS	\$262	TS73648HS	\$315
60"	TS73060HS	\$293	TS73660HS	\$349
72"	TS73072HS	\$327	TS73672HS	\$389

 **For Canadian Pricing**
 Multiply U.S. Price by the Canadian price factor.
 ▶ See page 1 for details.

Steel To The Floor Skins

For Panel Buildups

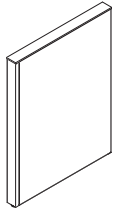

Tip: Remember to omit base trim(s) on horizontal frame package when using a skin to the floor.

Tip: Steel skins cannot accommodate power receptacles or communication outlets. Use a fabric skin for power access.

Tip: 30"H skins only work on junctions manufactured on or after October 10, 2011.

Tip: When specifying skins, the total skin height will be 6" less than the panel height. Skins to the floor are indicated by an F suffix. Plan 6" shorter than panel height, but skins to the floor are taller in actual height to cover the base trim area.

▶ See *Panel Buildups*, page 18, for more information.

Tip: Data and modular receptacle cutouts are available on 24"H steel skins only.

Tip: Data cutouts can be placed on the left or the right side of a steel beam skin. Data cutouts cannot be placed on both left and right side of steel beam skins.

Tip: Data cutout is an option under receptacle location. Specify data cutout location under the appropriate receptacle selection. Data cutout price is added to the receptacle cutout price.

Tip: On 24"W and 30"W steel skins, hardwire receptacle cutout option will always be with a centered hardwire cutout.



Tip: On 36"W and wider steel skins, hardwire receptacle cutout option will always come with a left and a right hardwire cutout.

Standard Includes		Required to Specify
▶ Need help? Product details, page 120	• Steel panel skin: paint price group 1	1 Style number 2 Paint color number for skin surface 3 Options, if selected (see below) ▶ See <i>Surface Materials</i> , page 668.

Options	U.S. Price			Required to Specify
Surface Materials	24"H-30"H	36"H		
• Paint price group 1	No cost	No cost		Specify paint color number.
• Paint price group 2	+\$35	+\$ 69		Specify paint color number.
• Paint price group 3	+\$59	+\$114		Specify paint color number.
Data Cutout Only (24"H only)	24"W-30"W	36"W	42"W-72"W	
• Left modular furniture data cutout or left NEMA data cutout	N.A.	N.A.	+\$12	Specify with left modular furniture data cutout or left NEMA data cutout.
• Right modular furniture data cutout or right NEMA data cutout	+\$12	+\$ 12	+\$12	Specify with right modular furniture data cutout or right NEMA data cutout.
Modular Receptacle Cutout (24"H only)				
• Center receptacle cutout	+\$12	N.A.	N.A.	Specify with center receptacle cutout.
• Center receptacle cutout with right modular furniture data cutout or right NEMA data cutout	+\$24	N.A.	N.A.	Specify with center receptacle cutout and right modular furniture data cutout or right NEMA data cutout.
• Left receptacle cutout	N.A.	+\$ 12	+\$12	Specify with left receptacle cutout.
• Left receptacle cutout with left modular furniture data cutout or left NEMA data cutout	N.A.	N.A.	+\$24	Specify with left receptacle cutout and left modular furniture data cutout or left NEMA data cutout.
• Right receptacle cutout	N.A.	+\$ 12	+\$12	Specify with right receptacle cutout.
• Right receptacle cutout with right modular furniture data cutout or right NEMA data cutout	N.A.	+\$ 24	+\$24	Specify with right receptacle cutout and right modular furniture data cutout or right NEMA data cutout.
• Left and right receptacle cutout	N.A.	+\$ 24	+\$24	Specify with left and right receptacle cutout.
• Left and right receptacle cutout with left modular furniture data cutout or left NEMA data cutout	N.A.	N.A.	+\$36	Specify with left and right receptacle cutout and left modular furniture data cutout or left NEMA data cutout.
• Left and right receptacle cutout with right modular furniture data cutout or right NEMA data cutout	N.A.	+\$ 36	+\$36	Specify with left and right receptacle cutout and right modular furniture data cutout or right NEMA data cutout.
Hardwire Power/Data Cutouts (24"H only)				
• Hardwired with receptacle cutout	+\$12	+\$ 12	+\$12	Specify with receptacle cutout.
• Hardwired with left receptacle cutout and left modular furniture data cutout or left NEMA data cutout	N.A.	N.A.	+\$24	Specify with left receptacle cutout and left modular furniture data cutout or left NEMA data cutout.
• Hardwired with right receptacle cutout and right modular furniture data cutout or right NEMA data cutout	+\$24	+\$ 24	+\$24	Specify with right receptacle cutout and right modular furniture data cutout or right NEMA data cutout.

Tip: No data or modular receptacle cutouts are available on 18"W steel skins.

Tip: Data or modular receptacle cutouts are NOT available on perforated or ribbed steel skins.

Specification Information						
	24"H		30"H		36"H	
						
Width	Style Number	U.S. Base Price	Style Number	U.S. Base Price	Style Number	U.S. Base Price
18"	TS72418HSF	\$159	TS73018HSF	\$190	TS73618HSF	\$221
24"	TS72424HSF	\$167	TS73024HSF	\$204	TS73624HSF	\$247
30"	TS72430HSF	\$185	TS73030HSF	\$221	TS73630HSF	\$263
36"	TS72436HSF	\$194	TS73036HSF	\$239	TS73636HSF	\$281
42"	TS72442HSF	\$204	TS73042HSF	\$254	TS73642HSF	\$300
48"	TS72448HSF	\$217	TS73048HSF	\$274	TS73648HSF	\$331
60"	TS72460HSF	\$252	TS73060HSF	\$307	TS73660HSF	\$362
72"	TS72472HSF	\$275	TS73072HSF	\$339	TS73672HSF	\$403



For Canadian Pricing
 Multiply U.S. Price by the
 Canadian price factor.
 ▶ See page 1 for details.

Steel Panel Skins Big Open Base

For Panel Buildups

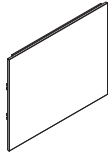

Tip: Data cutouts can be placed on the left or the right side of a steel panel skin. Data cutouts cannot be placed on both left and right side of steel panel skins.

Tip: Data cutouts is an option under receptacle location. Specify data cutout location under the appropriate receptacle selection. Data cutout price is additive to the receptacle cutout price.

Tip: No data or modular receptacle cutouts are available on 18"W steel skins.

Tip: On 24"W and 30"W steel skins, hardwire receptacle cutout option will always be with a centered hardwire cutout.

Tip: On 36"W and wider steel skins, hardwire receptacle cutout option will always come with a left and a right hardwire cutout.

Standard Includes		Required to Specify
▶ Need help? Product details, page 120	• 19 ³ / ₁₆ "H steel panel skin: paint price group 1	1 Style number 2 Paint color number for skin surface 3 Options, if selected (see below) ▶ See <i>Surface Materials</i> , page 668.

Options	U.S. Price			Required to Specify	
Surface Materials	• Paint price group 1 • Paint price group 2 • Paint price group 3	No cost +\$35 +\$59		Specify paint color number. Specify paint color number. Specify paint color number.	
Data Cutout Only		24"W-30"W	36"W	42"W-72"W	
• Left modular furniture data cutout or left NEMA data cutout	N.A.	N.A.		+\$12	Specify with left modular furniture data cutout or left NEMA data cutout.
• Right modular furniture data cutout or right NEMA data cutout	+\$12	+\$12		+\$12	Specify with right modular furniture data cutout or right NEMA data cutout.
Modular Receptacle Cutout					
• Center receptacle cutout	+\$12	N.A.	N.A.		Specify with center receptacle cutout.
• Center receptacle cutout with right modular furniture data cutout or right NEMA data cutout	+\$24	N.A.	N.A.		Specify with center receptacle cutout and right modular furniture data cutout or right NEMA data cutout.
• Left receptacle cutout	N.A.	+\$12	+\$12		Specify with left receptacle cutout.
• Left receptacle cutout with left modular furniture data cutout or left NEMA data cutout	N.A.	N.A.	+\$24		Specify with left receptacle cutout and left modular furniture data cutout or left NEMA data cutout.
• Right receptacle cutout	N.A.	+\$12	+\$12		Specify with right receptacle cutout.
• Right receptacle cutout with right modular furniture data cutout or right NEMA data cutout	N.A.	+\$24	+\$24		Specify with right receptacle cutout and right modular furniture data cutout or right NEMA data cutout.
• Left and right receptacle cutout	N.A.	+\$24	+\$24		Specify with left and right receptacle cutout.
• Left and right receptacle cutout with left modular furniture data cutout or left NEMA data cutout	N.A.	N.A.	+\$36		Specify with left and right receptacle cutout and left modular furniture data cutout or left NEMA data cutout.
• Left and right receptacle cutout with right modular furniture data cutout or right NEMA data cutout	N.A.	+\$36	+\$36		Specify with left and right receptacle cutout and right modular furniture data cutout or right NEMA data cutout.
Hardwire Power/Data Cutouts (24"H only)					
• Hardwired with receptacle cutout	+\$12	+\$12	+\$12		Specify with receptacle cutout.
• Hardwired with left receptacle cutout and left modular furniture data cutout or left NEMA data cutout	N.A.	N.A.	+\$24		Specify with left receptacle cutout and left modular furniture data cutout or left NEMA data cutout.
• Hardwired with right receptacle cutout and right modular furniture data cutout or right NEMA data cutout	+\$24	+\$24	+\$24		Specify with right receptacle cutout and right modular furniture data cutout or right NEMA data cutout.

Specification Information		
Width	Style Number	U.S. Base Price
18"	TS718HSBOB	\$116
24"	TS724HSBOB	\$124
30"	TS730HSBOB	\$141
36"	TS736HSBOB	\$148
42"	TS742HSBOB	\$155
48"	TS748HSBOB	\$167
60"	TS760HSBOB	\$190
72"	TS772HSBOB	\$214

 **For Canadian Pricing**
Multiply U.S. Price by the Canadian price factor.
▶ See page 1 for details.

Markerboard Surfaces for Steel Skins

For Panel Buildups

Markerboard Surfaces
for Steel Skins

Modular Markerboard Surface for Steel Skins

Tip: Remember to order steel skin of the same size to support markerboard surface.
▶ Page 442

Standard Includes		Required to Specify
▶ Need help? Product details, page 124	• Flexible, magnetic markerboard panel surface to attach to steel skin: white plastic	Style number

Specification Information

12"H		24"H		36"H		
Width	Style Number	U.S. Price	Style Number	U.S. Price	Style Number	U.S. Price
24"	TS71224MBS	\$137	TS72424MBS	\$171	TS73624MBS	\$210
30"	TS71230MBS	\$143	TS72430MBS	\$180	TS73630MBS	\$221
36"	TS71236MBS	\$149	TS72436MBS	\$186	TS73636MBS	\$231
42"	TS71242MBS	\$162	TS72442MBS	\$194	TS73642MBS	\$244
48"	TS71248MBS	\$171	TS72448MBS	\$203	TS73648MBS	\$258

Parametric Markerboard Surface for Steel Skins

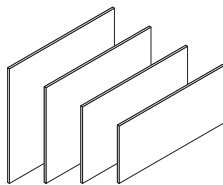

Standard Includes		Required to Specify
▶ Need help? Product details, page 124	• Flexible, magnetic markerboard panel surface to attach to steel skin: white plastic • Height: 12"H–36"H • Width: 12"W–96"W	1 Style number 2 Height 3 Width

Specification Information

Style Number	Width	U.S. Prices			
		12"H–16 ³ / ₁₆ "H	16 ¹ / ₄ "H–23 ¹⁵ / ₁₆ "H	24"H–35 ¹⁵ / ₁₆ "H	36"H
TS7MBSP	12"W–17 ¹⁵ / ₁₆ "W	\$125	\$140	\$153	\$183
	18"W–23 ¹⁵ / ₁₆ "W	\$132	\$148	\$160	\$194
	24"W–29 ¹⁵ / ₁₆ "W	\$137	\$158	\$171	\$210
	30"W–35 ¹⁵ / ₁₆ "W	\$143	\$168	\$180	\$221
	36"W–41 ¹⁵ / ₁₆ "W	\$149	\$182	\$186	\$231
	42"W–47 ¹⁵ / ₁₆ "W	\$162	\$187	\$194	\$244
	48"W–53 ¹⁵ / ₁₆ "W	\$171	\$198	\$203	\$258
	54"W–59 ¹⁵ / ₁₆ "W	\$177	\$210	\$214	\$271
	60"W–65 ¹⁵ / ₁₆ "W	\$185	\$219	\$220	\$284
	66"W–71 ¹⁵ / ₁₆ "W	\$190	\$228	\$239	\$294
	72"W–77 ¹⁵ / ₁₆ "W	\$198	\$239	\$250	\$311
	78"W–83 ¹⁵ / ₁₆ "W	\$208	\$247	\$263	\$325
	84"W–89 ¹⁵ / ₁₆ "W	\$217	\$258	\$278	\$339
	90"W–95 ¹⁵ / ₁₆ "W	\$226	\$270	\$290	\$358
	96"W	\$239	\$292	\$305	\$380

 **For Canadian Pricing**
Multiply U.S. Price by the Canadian price factor.
▶ See page 1 for details.



Markerboard Skins

For Panel Buildups

Tip: 18"H and 30"H skins only work on junctions manufactured on or after October 10, 2011.

Standard Includes	Required to Specify
<ul style="list-style-type: none"> ▶ Need help? Product details, page 125 • Markerboard skin: white 	<ul style="list-style-type: none"> Style number

Specification Information

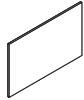
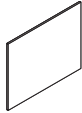
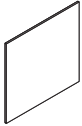
	12"H		18"H		24"H		30"H		36"H	
										
• Width	• Style Number	• U.S. Price	• Style Number	• U.S. Price	• Style Number	• U.S. Price	• Style Number	• U.S. Price	• Style Number	• U.S. Price
18"	TS71218MB	\$221	TS71818MB	\$268	TS72418MB	\$312	TS73018MB	\$368	TS73618MB	\$429
24"	TS71224MB	\$239	TS71824MB	\$287	TS72424MB	\$332	TS73024MB	\$391	TS73624MB	\$456
30"	TS71230MB	\$256	TS71830MB	\$308	TS72430MB	\$359	TS73030MB	\$424	TS73630MB	\$484
36"	TS71236MB	\$268	TS71836MB	\$324	TS72436MB	\$376	TS73036MB	\$447	TS73636MB	\$514
42"	TS71242MB	\$290	TS71842MB	\$343	TS72442MB	\$396	TS73042MB	\$472	TS73642MB	\$546
48"	TS71248MB	\$310	TS71848MB	\$364	TS72448MB	\$423	TS73048MB	\$502	TS73648MB	\$586
60"	TS71260MB	\$331	TS71860MB	\$386	TS72460MB	\$446	TS73060MB	\$541	TS73660MB	\$623
72"	TS71272MB	\$352	TS71872MB	\$410	TS72472MB	\$471	TS73072MB	\$567	TS73672MB	\$653



For Canadian Pricing

Multiply U.S. Price by the Canadian price factor.

▶ See page 1 for details.

Markerboard To The Floor Skins

For Panel Buildups

Markerboard To
The Floor Skins

Tip: 18"H and 30"H skins only work on junctions manufactured on or after October 10, 2011.

Standard Includes		Required to Specify
▶ Need help? Product details, page 125	• Markerboard skin: white	Style number

Specification Information

Width	24"H		30"H		36"H	
	Style Number	U.S. Price	Style Number	U.S. Price	Style Number	U.S. Price
18"	TS72418MBF	\$346	TS73018MBF	\$408	TS73618MBF	\$463
24"	TS72424MBF	\$361	TS73024MBF	\$425	TS73624MBF	\$492
30"	TS72430MBF	\$386	TS73030MBF	\$457	TS73630MBF	\$522
36"	TS72436MBF	\$408	TS73036MBF	\$480	TS73636MBF	\$555
42"	TS72442MBF	\$429	TS73042MBF	\$511	TS73642MBF	\$586
48"	TS72448MBF	\$446	TS73048MBF	\$532	TS73648MBF	\$625
60"	TS72460MBF	\$465	TS73060MBF	\$569	TS73660MBF	\$652
72"	TS72472MBF	\$494	TS73072MBF	\$605	TS73672MBF	\$686

Shared Components

 **For Canadian Pricing**
Multiply U.S. Price by the Canadian price factor.
▶ See page 1 for details.

Slatwall Skins and Slatwall Skin Brace Packages

Slatwall Skins

Standard Includes	Required to Specify
<ul style="list-style-type: none"> ▶ Need help? Product details, page 126 • Skin with slatwall channels to accommodate work tools: paint • Attachment hardware 	<ul style="list-style-type: none"> 1 Style number 2 Paint color number ▶ See <i>Surface Materials</i>, page 668.

Tip: 18"H skins only work on junctions manufactured on or after October 10, 2011.

Tip: Slatwall skins cannot be used in the bottom 12" of an Answer panel.

Specification Information

Width	12"H		18"H		24"H	
	Style Number	U.S. Price	Style Number	U.S. Price	Style Number	U.S. Price
24"	TS71224SW	\$367	TS71824SW	\$449	TS72424SW	\$528
30"	TS71230SW	\$424	TS71830SW	\$504	TS72430SW	\$586
36"	TS71236SW	\$504	TS71836SW	\$594	TS72436SW	\$679
42"	TS71242SW	\$534	TS71842SW	\$621	TS72442SW	\$701
48"	TS71248SW	\$567	TS71848SW	\$650	TS72448SW	\$734



For Canadian Pricing

Multiply U.S. Price by the Canadian price factor.



▶ See page 1 for details.

Slatwall Skin Brace Packages

For Use with Answer Slatwall Skins

Standard Includes	Required to Specify
<ul style="list-style-type: none"> ▶ Need help? Product details, page 126 • Brace packages: black only • Attachment hardware 	<ul style="list-style-type: none"> Style number

Specification Information

Specification Information						
12"H			18"H		24"H	
						
						
Width	Style Number	U.S. Price	Style Number	U.S. Price	Style Number	U.S. Price
24"	TS71224SBP	\$112	TS71824SBP	\$140	TS72424SBP	\$154
30"	TS71230SBP	\$112	TS71830SBP	\$140	TS72430SBP	\$154
36"	TS71236SBP	\$137	TS71836SBP	\$149	TS72436SBP	\$154
42"	TS71242SBP	\$137	TS71842SBP	\$174	TS72442SBP	\$204
48"	TS71248SBP	\$137	TS71848SBP	\$174	TS72448SBP	\$204



For Canadian Pricing

Multiply U.S. Price by the Canadian price factor.

▶ See page 1 for details.

Laminate Skins

Standard Includes		Required to Specify
<ul style="list-style-type: none"> ▶ Need help? Product details, page 128 	<ul style="list-style-type: none"> • Skin: laminate price group 1 • Vertical grain direction for woodgrain and directional laminates • Trim: paint • Attachment hardware 	<ol style="list-style-type: none"> 1 Style number 2 Laminate color for skin surface 3 Paint color number for trim 4 Options, if selected (see below) <ul style="list-style-type: none"> ▶ See <i>Surface Materials</i>, page 668.

For laminate price group 2 and 3 pricing, please refer to the electronic catalog or SmartTools.

Options	U.S. Price	Required to Specify
Surface Materials <ul style="list-style-type: none"> • Laminate price group 2 • Laminate price group 3 • Open Line laminate 	See information at left See information at left +\$102 plus cost of laminate	Specify laminate color number. Specify laminate color number. ▶ See <i>Surface Materials Reference Manual</i> .
Grain direction (for all skins up to 48"H only) <ul style="list-style-type: none"> • Horizontal 		Specify with horizontal grain direction.

Tip: 18"H, 30"H, and 42"H skins only work on junctions manufactured on or after October 10, 2011.

Specification Information											
12"H			18"H			24"H			30"H		
Width	Style Number	U.S. Base Price	Style Number	U.S. Base Price	Style Number	U.S. Base Price	Style Number	U.S. Base Price			
24"	TS71224LS	\$455	TS71824LS	\$488	TS72424LS	\$521	TS73024LS	\$583			
30"	TS71230LS	\$470	TS71830LS	\$509	TS72430LS	\$550	TS73030LS	\$600			
36"	TS71236LS	\$484	TS71836LS	\$526	TS72436LS	\$574	TS73036LS	\$627			
42"	TS71242LS	\$513	TS71842LS	\$556	TS72442LS	\$602	TS73042LS	\$657			
48"	TS71248LS	\$526	TS71848LS	\$578	TS72448LS	\$628	TS73048LS	\$688			

Tip: All 60"H skins are only available in vertical direction for woodgrain and directional laminates.

36"H			42"H			48"H			60"H		
Width	Style Number	U.S. Base Price	Style Number	U.S. Base Price	Style Number	U.S. Base Price	Style Number	U.S. Base Price			
24"	TS73624LS	\$583	TS74224LS	\$603	TS74824LS	\$626	TS76024LS	\$716			
30"	TS73630LS	\$649	TS74230LS	\$652	TS74830LS	\$655	TS76030LS	\$750			
36"	TS73636LS	\$673	TS74236LS	\$691	TS74836LS	\$714	TS76036LS	\$794			
42"	TS73642LS	\$715	TS74242LS	\$734	TS74842LS	\$748	TS76042LS	\$826			
48"	TS73648LS	\$759	TS74248LS	\$786	TS74848LS	\$815	TS76048LS	\$919			



For Canadian Pricing
 Multiply U.S. Price by the Canadian price factor.
 ▶ See page 1 for details.

Laminate To The Floor Skins

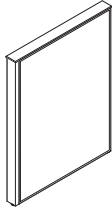

Standard Includes	Required to Specify
<ul style="list-style-type: none"> ▶ Need help? Product details, page 128 • Skin: laminate price group 1 • Vertical grain direction for woodgrain and directional laminates • Trim: paint • Attachment hardware 	<ol style="list-style-type: none"> 1 Style number 2 Laminate color for skin surface 3 Paint color number for trim 4 Options, if selected (see below) <ul style="list-style-type: none"> ▶ See <i>Surface Materials</i>, page 668.

For laminate price group 2 and 3 pricing, please refer to the electronic catalog or SmartTools.

Tip: Remember to omit base trim(s) on horizontal frame package when using a skin to the floor.

Tip: 30"H and 42"H skins only work on junctions manufactured on or after October 10, 2011.

Tip: When specifying skins, the total skin height will be 6" less than the panel height. Skins to the floor are indicated by an F suffix. Plan 6" shorter than panel height, but skins to the floor are taller in actual height to cover the base trim area.
▶ See *Panel Buildups*, page 18, for more information.

Tip: All 60"H skins are only available in vertical direction for woodgrain and directional laminates.

Options	U.S. Price	Required to Specify
Surface Materials <ul style="list-style-type: none"> • Laminate price group 2 • Laminate price group 3 • Open Line laminate 	See information at left See information at left +\$102 plus cost of laminate	Specify laminate color number. Specify laminate color number. ▶ See <i>Surface Materials Reference Manual</i> .
Grain direction (for all skins up to 48"H only)		
<ul style="list-style-type: none"> • Horizontal 	No cost	Specify with horizontal grain direction.

Specification Information

24"H		30"H		36"H		
Width	Style Number	U.S. Base Price	Style Number	U.S. Base Price	Style Number	U.S. Base Price
24"	TS72424LSF	\$550	TS73024LSF	\$579	TS73624LSF	\$611
30"	TS72430LSF	\$576	TS73030LSF	\$628	TS73630LSF	\$675
36"	TS72436LSF	\$601	TS73036LSF	\$649	TS73636LSF	\$698
42"	TS72442LSF	\$630	TS73042LSF	\$685	TS73642LSF	\$744
48"	TS72448LSF	\$652	TS73048LSF	\$716	TS73648LSF	\$782

42"H		48"H		60"H		
Width	Style Number	U.S. Base Price	Style Number	U.S. Base Price	Style Number	U.S. Base Price
24"	TS74224LSF	\$631	TS74824LSF	\$649	TS76024LSF	\$746
30"	TS74230LSF	\$677	TS74830LSF	\$680	TS76030LSF	\$776
36"	TS74236LSF	\$717	TS74836LSF	\$743	TS76036LSF	\$822
42"	TS74242LSF	\$760	TS74842LSF	\$771	TS76042LSF	\$850
48"	TS74248LSF	\$814	TS74848LSF	\$837	TS76048LSF	\$945

For Canadian Pricing
Multiply U.S. Price by the Canadian price factor.
▶ See page 1 for details.

Wood Skins

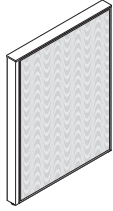

Tip: 18"H, 30"H, and 42"H skins only work on junctions manufactured on or after October 10, 2011.

Tip: Vertical grain cathedral direction will point up. The cathedral direction for horizontal grain is random.

Standard Includes	Required to Specify
-------------------	---------------------

- | | | |
|------------------------------------------------------------------------------------------|-------------------------------------------------------------------------------------------------------------------------------------------------------------------------|------------------------------------------------------------------------------------------------------------------------------------------------------------------------------------------------------------------------------------------------------------------------|
| <ul style="list-style-type: none"> ▶ Need help? Product details, page 130 | <ul style="list-style-type: none"> • Skin: wood veneer group 1 • Vertical grain direction • Trim: paint • Attachment hardware | <ol style="list-style-type: none"> 1 Style number 2 Composite veneer or wood veneer color for skin surface 3 Paint color number for trim 4 Options, if selected (see below) <p>▶ See <i>Surface Materials</i>, page 668.</p> |
|------------------------------------------------------------------------------------------|-------------------------------------------------------------------------------------------------------------------------------------------------------------------------|------------------------------------------------------------------------------------------------------------------------------------------------------------------------------------------------------------------------------------------------------------------------|

Options	U.S. Price	Required to Specify
---------	------------	---------------------

- | | | |
|----------------------------------------------------------------------------------------------------------------------------------------------------------------------------------------------------------------------------|----------------------------------------------------------------------------------------------------------------------------------|--------------------------------------------------------------------------------------------------------------------------------------------------------------------------------------------------------------------------------------------------------------------|
| <p>Surface Materials</p> <ul style="list-style-type: none"> • Composite veneer group 1 • Composite veneer group 2 • Wood group 2 • Wood group 3 • Customiz stain | <p>No cost</p> <p>Prices below and at right</p> <p>Prices below and at right</p> <p>Prices below and at right</p> <p>No cost</p> | <p>Specify composite veneer color number.</p> <p>Specify composite veneer color number.</p> <p>Specify wood color number.</p> <p>Specify wood color number.</p> <p>Specify with <i>Customiz stain</i>.</p> <p>▶ See <i>Surface Materials Reference Manual</i>.</p> |
|----------------------------------------------------------------------------------------------------------------------------------------------------------------------------------------------------------------------------|----------------------------------------------------------------------------------------------------------------------------------|--------------------------------------------------------------------------------------------------------------------------------------------------------------------------------------------------------------------------------------------------------------------|

Grain direction

- | | | |
|----------------------------------------------------------------|----------------|--------------------------------------------------------|
| <ul style="list-style-type: none"> • Horizontal | <p>No cost</p> | <p>Specify with <i>horizontal grain direction</i>.</p> |
|----------------------------------------------------------------|----------------|--------------------------------------------------------|

Specification Information

12"H						18"H					
Width	Style Number	U.S. Base Price	Options (Add \$ to Base Price)			Style Number	U.S. Base Price	Options (Add \$ to Base Price)			
			Composite Veneer Group 2	Wood Group 2	Wood Group 3			Composite Veneer Group 2	Wood Group 2	Wood Group 3	
24"	TS71224WS	\$548	+\$81	+\$81	+\$288	TS71824WS	\$631	+\$ 81	+\$ 81	+\$288	
30"	TS71230WS	\$584	+\$81	+\$81	+\$288	TS71830WS	\$670	+\$ 81	+\$ 81	+\$288	
36"	TS71236WS	\$626	+\$81	+\$81	+\$288	TS71836WS	\$713	+\$137	+\$137	+\$484	
42"	TS71242WS	\$667	+\$81	+\$81	+\$288	TS71842WS	\$762	+\$137	+\$137	+\$484	
48"	TS71248WS	\$710	+\$81	+\$81	+\$288	TS71848WS	\$801	+\$137	+\$137	+\$484	
24"H						30"H					
Width	Style Number	U.S. Base Price	Options (Add \$ to Base Price)			Style Number	U.S. Base Price	Options (Add \$ to Base Price)			
			Composite Veneer Group 2	Wood Group 2	Wood Group 3			Composite Veneer Group 2	Wood Group 2	Wood Group 3	
24"	TS72424WS	\$710	+\$ 81	+\$ 81	+\$288	TS73024WS	\$ 828	+\$137	+\$137	+\$484	
30"	TS72430WS	\$754	+\$ 81	+\$ 81	+\$288	TS73030WS	\$ 875	+\$137	+\$137	+\$484	
36"	TS72436WS	\$797	+\$137	+\$137	+\$484	TS73036WS	\$ 925	+\$137	+\$137	+\$484	
42"	TS72442WS	\$846	+\$137	+\$137	+\$484	TS73042WS	\$ 981	+\$204	+\$204	+\$716	
48"	TS72448WS	\$895	+\$137	+\$137	+\$484	TS73048WS	\$1047	+\$204	+\$204	+\$716	

▶ Specification Information, continued on next page



For Canadian Pricing

Multiply U.S. Price by the Canadian price factor.

▶ See page 1 for details.

► Specification Information, continued from previous page

Specification Information

36"H						42"H					
Width	Style Number	U.S. Base Price	Options (Add \$ to Base Price)			Style Number	U.S. Base Price	Options (Add \$ to Base Price)			
			Composite Veneer Group 2	Wood Group 2	Wood Group 3			Composite Veneer Group 2	Wood Group 2	Wood Group 3	
24"	TS73624WS	\$ 945	+\$137	+\$137	+\$484	TS74224WS	\$1001	+\$137	+\$137	+\$484	
30"	TS73630WS	\$ 998	+\$137	+\$137	+\$484	TS74230WS	\$1053	+\$137	+\$137	+\$484	
36"	TS73636WS	\$1051	+\$137	+\$137	+\$484	TS74236WS	\$1106	+\$204	+\$204	+\$716	
42"	TS73642WS	\$1107	+\$204	+\$204	+\$716	TS74242WS	\$1164	+\$204	+\$204	+\$716	
48"	TS73648WS	\$1203	+\$204	+\$204	+\$716	TS74248WS	\$1259	+\$204	+\$204	+\$716	

48"H						60"H					
Width	Style Number	U.S. Base Price	Options (Add \$ to Base Price)			Style Number	U.S. Base Price	Options (Add \$ to Base Price)			
			Composite Veneer Group 2	Wood Group 2	Wood Group 3			Composite Veneer Group 2	Wood Group 2	Wood Group 3	
24"	TS74824WS	\$1059	+\$137	+\$137	+\$484	TS76024WS	\$1225	+\$137	+\$137	+\$ 484	
30"	TS74830WS	\$1107	+\$137	+\$137	+\$484	TS76030WS	\$1270	+\$204	+\$204	+\$ 716	
36"	TS74836WS	\$1161	+\$204	+\$204	+\$716	TS76036WS	\$1321	+\$204	+\$204	+\$ 716	
42"	TS74842WS	\$1222	+\$204	+\$204	+\$716	TS76042WS	\$1381	+\$287	+\$287	+\$1000	
48"	TS74848WS	\$1315	+\$204	+\$204	+\$716	TS76048WS	\$1478	+\$287	+\$287	+\$1000	

 **For Canadian Pricing**
 Multiply U.S. Price by the Canadian price factor.
 ► See page 1 for details.

Wood To The Floor Skins

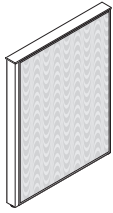

Tip: Remember to omit base trim(s) on horizontal frame package when using a skin to the floor.

Tip: 18"H, 30"H, and 42"H skins only work on junctions manufactured on or after October 10, 2011.

Tip: When specifying skins, the total skin height will be 6" less than the panel height. Skins to the floor are indicated by an F suffix. Plan 6" shorter than panel height, but skins to the floor are taller in actual height to cover the base trim area.

▶ See Panel Buildups, page 18, for more information.

Standard Includes		Required to Specify
▶ Need help? Product details, page 130	<ul style="list-style-type: none"> • Skin: wood group 1 veneer • Vertical grain direction • Trim: paint • Attachment hardware 	<ol style="list-style-type: none"> 1 Style number 2 Composite veneer or wood veneer color for skin surface 3 Paint color number for trim 4 Options, if selected (see below) <p>▶ See <i>Surface Materials</i>, page 668.</p>

Options	U.S. Price	Required to Specify
Surface Materials <ul style="list-style-type: none"> • Composite veneer group 1 • Composite veneer group 2 • Wood group 2 • Wood group 3 • Customiz stain 	No cost Prices below and at right Prices below and at right Prices below and at right No cost	Specify composite veneer color number. Specify composite veneer color number. Specify wood color number. Specify wood color number. Specify with <i>Customiz stain</i> . ▶ See <i>Surface Materials Reference Manual</i> .
Grain direction <ul style="list-style-type: none"> • Horizontal 	No cost	Specify with <i>horizontal grain direction</i> .

Specification Information

24"H						30"H				
Width	Style Number	U.S. Base Price	Options (Add \$ to Base Price)			Style Number	U.S. Base Price	Options (Add \$ to Base Price)		
			Composite Veneer Group 2	Wood Group 2	Wood Group 3			Composite Veneer Group 2	Wood Group 2	Wood Group 3
24"	TS72424WSF	\$739	+\$ 81	+\$ 81	+\$288	TS73024WSF	\$ 853	+\$137	+\$137	+\$484
30"	TS72430WSF	\$778	+\$ 81	+\$ 81	+\$288	TS73030WSF	\$ 901	+\$137	+\$137	+\$484
36"	TS72436WSF	\$827	+\$137	+\$137	+\$484	TS73036WSF	\$ 952	+\$137	+\$137	+\$484
42"	TS72442WSF	\$875	+\$137	+\$137	+\$484	TS73042WSF	\$1004	+\$204	+\$204	+\$716
48"	TS72448WSF	\$923	+\$137	+\$137	+\$484	TS73048WSF	\$1076	+\$204	+\$204	+\$716

▶ Specification Information, continued on next page



For Canadian Pricing

Multiply U.S. Price by the Canadian price factor.

▶ See page 1 for details.

► Specification Information, continued from previous page

Specification Information										
36"H						42"H				
Width	Style Number	U.S. Base Price	Options (Add \$ to Base Price)			Style Number	U.S. Base Price	Options (Add \$ to Base Price)		
			Composite Veneer Group 2	Wood Group 2	Wood Group 3			Composite Veneer Group 2	Wood Group 2	Wood Group 3
24"	TS73624WSF	\$ 973	+\$137	+\$137	+\$484	TS74224WSF	\$1028	+\$137	+\$137	+\$484
30"	TS73630WSF	\$1025	+\$137	+\$137	+\$484	TS74230WSF	\$1081	+\$137	+\$137	+\$484
36"	TS73636WSF	\$1078	+\$137	+\$137	+\$484	TS74236WSF	\$1134	+\$204	+\$204	+\$716
42"	TS73642WSF	\$1136	+\$204	+\$204	+\$716	TS74242WSF	\$1189	+\$204	+\$204	+\$716
48"	TS73648WSF	\$1228	+\$204	+\$204	+\$716	TS74248WSF	\$1286	+\$204	+\$204	+\$716

48"H						60"H				
Width	Style Number	U.S. Base Price	Options (Add \$ to Base Price)			Style Number	U.S. Base Price	Options (Add \$ to Base Price)		
			Composite Veneer Group 2	Wood Group 2	Wood Group 3			Composite Veneer Group 2	Wood Group 2	Wood Group 3
24"	TS74824WSF	\$1092	+\$137	+\$137	+\$484	TS76024WSF	\$1250	+\$137	+\$137	+\$ 484
30"	TS74830WSF	\$1136	+\$137	+\$137	+\$484	TS76030WSF	\$1295	+\$204	+\$204	+\$ 716
36"	TS74836WSF	\$1185	+\$204	+\$204	+\$716	TS76036WSF	\$1345	+\$204	+\$204	+\$ 716
42"	TS74842WSF	\$1248	+\$204	+\$204	+\$716	TS76042WSF	\$1410	+\$287	+\$287	+\$1000
48"	TS74848WSF	\$1342	+\$204	+\$204	+\$716	TS76048WSF	\$1503	+\$287	+\$287	+\$1000

 **For Canadian Pricing**
 Multiply U.S. Price by the Canadian price factor.
 ► See page 1 for details.

Wood Skin Sets

Tip: Wood skin sets should be selected when grain pattern alignment of all segmented skins on a frame is desired.

Standard Includes	Required to Specify
<ul style="list-style-type: none"> ▶ Need help? Product details, page 130 • Skin: wood group 1 veneer • Vertical grain direction • Trim: paint • Attachment hardware 	<ol style="list-style-type: none"> 1 Style number 2 Composite veneer or wood veneer color for skin surface 3 Paint color number for trim 4 Options, if selected (see below) <p>▶ See <i>Surface Materials</i>, page 668.</p>

Options	U.S. Price	Required to Specify
Surface Materials <ul style="list-style-type: none"> • Composite veneer group 1 • Composite veneer group 2 • Wood group 2 • Wood group 3 • Customiz stain 	No cost Prices below and at right Prices below and at right Prices below and at right No cost	Specify composite veneer color number. Specify composite veneer color number. Specify wood color number. Specify wood color number. Specify <i>with Customiz stain</i> . ▶ See <i>Surface Materials Reference Manual</i> .
Grain direction <ul style="list-style-type: none"> • Horizontal 	No cost	Specify <i>with horizontal grain direction</i> .

Specification Information			
Width	Style Number	U.S. Base Price	Options (Add \$ to Base Price)
.....	Composite Veneer Group 2 : Wood Group 2 : Wood Group 3

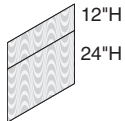

42"H Wood Skin Sets

Set A = One 12"H Skin and One 24"H Skin

24"	TS74224AWSS	\$1293	+\$161	+\$161	+\$ 562
30"	TS74230AWSS	\$1376	+\$161	+\$161	+\$ 562
36"	TS74236AWSS	\$1468	+\$222	+\$222	+\$ 772
42"	TS74242AWSS	\$1559	+\$222	+\$222	+\$ 772
48"	TS74248AWSS	\$1655	+\$222	+\$222	+\$ 772

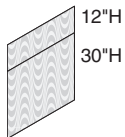

48"H Wood Skin Sets

Set A = One 12"H Skin and One 30"H Skin

24"	TS74824AWSS	\$1419	+\$222	+\$222	+\$ 772
30"	TS74830AWSS	\$1503	+\$222	+\$222	+\$ 772
36"	TS74836AWSS	\$1598	+\$222	+\$222	+\$ 772
42"	TS74842AWSS	\$1693	+\$287	+\$287	+\$1000
48"	TS74848AWSS	\$1813	+\$287	+\$287	+\$1000

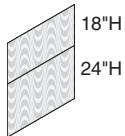

Set B = One 18"H Skin and One 24"H Skin

24"	TS74824BWSS	\$1419	+\$228	+\$228	+\$ 796
30"	TS74830BWSS	\$1503	+\$228	+\$228	+\$ 796
36"	TS74836BWSS	\$1598	+\$228	+\$228	+\$ 796
42"	TS74842BWSS	\$1693	+\$299	+\$299	+\$1038
48"	TS74848BWSS	\$1813	+\$299	+\$299	+\$1038

For Canadian Pricing
 Multiply U.S. Price by the Canadian price factor.
 ▶ See page 1 for details.

▶ **Specification Information, continued on next page**

► Specification Information, continued from previous page

Specification Information					
Width	Style Number	U.S. Base Price	Options (Add \$ to Base Price)		
			Composite Veneer Group 2	Wood Group 2	Wood Group 3

54"H Wood Skin Sets

Set A = Two 24"H Skins

24"	TS75424AWSS	\$1464	+\$161	+\$161	+\$ 562
30"	TS75430AWSS	\$1558	+\$161	+\$161	+\$ 562
36"	TS75436AWSS	\$1647	+\$277	+\$277	+\$ 967
42"	TS75442AWSS	\$1740	+\$277	+\$277	+\$ 967
48"	TS75448AWSS	\$1841	+\$277	+\$277	+\$ 967

Set B = Two 12"H Skins and One 24"H Skin

24"	TS75424BWSS	\$1854	+\$242	+\$242	+\$ 852
30"	TS75430BWSS	\$1987	+\$242	+\$242	+\$ 852
36"	TS75436BWSS	\$2114	+\$303	+\$303	+\$1057
42"	TS75442BWSS	\$2248	+\$303	+\$303	+\$1057
48"	TS75448BWSS	\$2386	+\$303	+\$303	+\$1057

Set C = One 12"H Skin and One 36"H Skin

24"	TS75424CWSS	\$1539	+\$222	+\$222	+\$ 772
30"	TS75430CWSS	\$1632	+\$222	+\$222	+\$ 772
36"	TS75436CWSS	\$1728	+\$222	+\$222	+\$ 772
42"	TS75442CWSS	\$1826	+\$287	+\$287	+\$1000
48"	TS75448CWSS	\$1972	+\$287	+\$287	+\$1000

66"H Wood Skin Sets

Set A = Three 12"H Skins and One 24"H Skin

24"	TS76624AWSS	\$2425	+\$325	+\$325	+\$1137
30"	TS76630AWSS	\$2590	+\$325	+\$325	+\$1137
36"	TS76636AWSS	\$2754	+\$379	+\$379	+\$1331
42"	TS76642AWSS	\$2931	+\$379	+\$379	+\$1331
48"	TS76648AWSS	\$3113	+\$379	+\$379	+\$1331

► Specification Information, continued on next page

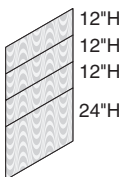
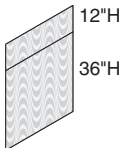
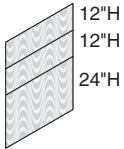
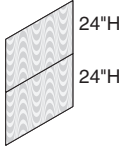

 **For Canadian Pricing**
 Multiply U.S. Price by the Canadian price factor.
 ► See page 1 for details.

Wood Skin Sets, continued

► Specification Information, continued from previous page

Specification Information			
Width	Style Number	U.S. Base Price	Options (Add \$ to Base Price)
			Composite Veneer Group 2
			Wood Group 2
			Wood Group 3

66"H Wood Skin Sets, continued

Set B = One 12"H Skin and Two 24"H Skins

Width	Style Number	U.S. Base Price	Options	U.S. Price	Canadian Price
24"	TS76624BWSS	\$2025	+\$242	+\$242	+\$ 852
30"	TS76630BWSS	\$2160	+\$242	+\$242	+\$ 852
36"	TS76636BWSS	\$2290	+\$360	+\$360	+\$1256
42"	TS76642BWSS	\$2429	+\$360	+\$360	+\$1256
48"	TS76648BWSS	\$2572	+\$360	+\$360	+\$1256

Set C = Two 12"H Skins and One 36"H Skin

Width	Style Number	U.S. Base Price	Options	U.S. Price	Canadian Price
24"	TS76624CWSS	\$2106	+\$303	+\$303	+\$1057
30"	TS76630CWSS	\$2238	+\$303	+\$303	+\$1057
36"	TS76636CWSS	\$2370	+\$303	+\$303	+\$1057
42"	TS76642CWSS	\$2514	+\$365	+\$365	+\$1275
48"	TS76648CWSS	\$2700	+\$365	+\$365	+\$1275

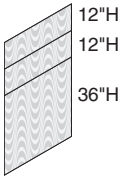
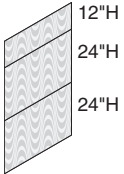

For Canadian Pricing

Multiply U.S. Price by the Canadian price factor.

► See page 1 for details.

Wood To The Floor Skin Sets

Tip: Wood skin sets should be selected when grain pattern alignment of all segmented skins on a frame is desired.

Tip: Remember to omit base trim(s) on horizontal frame package when using a skin to the floor.

Tip: When specifying skins, the total skin height will be 6" less than the panel height. Skins to the floor are indicated by an F suffix. Plan 6" shorter than panel height, but skins to the floor are taller in actual height to cover the base trim area.
 ▶ See Panel Buildups, page 18, for more information.

Standard Includes		Required to Specify
▶ Need help? Product details, page 130	<ul style="list-style-type: none"> • Skin: wood group 1 veneer • Vertical grain direction • Trim: paint • Attachment hardware 	1 Style number 2 Composite veneer or wood veneer color for skin surface 3 Paint color number for trim 4 Options, if selected (see below) ▶ See <i>Surface Materials</i> , page 668.

Options	U.S. Price	Required to Specify
Surface Materials <ul style="list-style-type: none"> • Composite veneer group 1 • Composite veneer group 2 • Wood group 2 • Wood group 3 • Customiz stain 	No cost Prices below and at right Prices below and at right Prices below and at right No cost	Specify composite veneer color number. Specify composite veneer color number. Specify wood color number. Specify wood color number. Specify with <i>Customiz stain</i> . ▶ See <i>Surface Materials Reference Manual</i> .
Grain direction <ul style="list-style-type: none"> • Horizontal 	No cost	Specify with <i>horizontal grain direction</i> .

Specification Information						
Width	Style Number	U.S. Base Price	Options (Add \$ to Base Price)			
.....	Composite Veneer Group 2	Wood Group 2	Wood Group 3

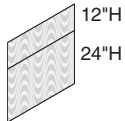

42"H Wood Skin Sets

Set A = One 12"H Skin and One 24"H Skin

24"	TS74224AWSF	\$1322	+\$161	+\$161	+\$ 562
30"	TS74230AWSF	\$1408	+\$161	+\$161	+\$ 562
36"	TS74236AWSF	\$1494	+\$222	+\$222	+\$ 772
42"	TS74242AWSF	\$1587	+\$222	+\$222	+\$ 772
48"	TS74248AWSF	\$1680	+\$222	+\$222	+\$ 772

48"H Wood Skin Sets

Set A = One 12"H Skin and One 30"H Skin

24"	TS74824AWSF	\$1444	+\$222	+\$222	+\$ 772
30"	TS74830AWSF	\$1530	+\$222	+\$222	+\$ 772
36"	TS74836AWSF	\$1622	+\$222	+\$222	+\$ 772
42"	TS74842AWSF	\$1721	+\$287	+\$287	+\$1000
48"	TS74848AWSF	\$1839	+\$287	+\$287	+\$1000

Set B = One 18"H Skin and One 24"H Skin

24"	TS74824BWSF	\$1444	+\$228	+\$228	+\$ 796
30"	TS74830BWSF	\$1530	+\$228	+\$228	+\$ 796
36"	TS74836BWSF	\$1622	+\$228	+\$228	+\$ 796
42"	TS74842BWSF	\$1721	+\$299	+\$299	+\$1038
48"	TS74848BWSF	\$1839	+\$299	+\$299	+\$1038

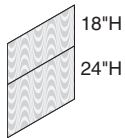
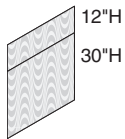

For Canadian Pricing
 Multiply U.S. Price by the Canadian price factor.
 ▶ See page 1 for details.

▶ **Specification Information, continued on next page**

► Specification Information, continued from previous page

Specification Information					
Width	Style Number	U.S. Base Price	Options (Add \$ to Base Price)		
			Composite Veneer Group 2	Wood Group 2	Wood Group 3

54"H Wood Skin Sets

Set A = Two 24"H Skins

24"	TS75424AWSF	\$1490	+\$161	+\$161	+\$ 562
30"	TS75430AWSF	\$1585	+\$161	+\$161	+\$ 562
36"	TS75436AWSF	\$1673	+\$277	+\$277	+\$ 967
42"	TS75442AWSF	\$1768	+\$277	+\$277	+\$ 967
48"	TS75448AWSF	\$1866	+\$277	+\$277	+\$ 967

Set B = Two 12"H Skins and One 24"H Skin

24"	TS75424BWSF	\$1891	+\$242	+\$242	+\$ 852
30"	TS75430BWSF	\$2013	+\$242	+\$242	+\$ 852
36"	TS75436BWSF	\$2139	+\$303	+\$303	+\$1057
42"	TS75442BWSF	\$2270	+\$303	+\$303	+\$1057
48"	TS75448BWSF	\$2412	+\$303	+\$303	+\$1057

Set C = One 12"H Skin and One 36"H Skin

24"	TS75424CWSF	\$1566	+\$222	+\$222	+\$ 772
30"	TS75430CWSF	\$1662	+\$222	+\$222	+\$ 772
36"	TS75436CWSF	\$1754	+\$222	+\$222	+\$ 772
42"	TS75442CWSF	\$1852	+\$287	+\$287	+\$1000
48"	TS75448CWSF	\$1996	+\$287	+\$287	+\$1000

66"H Wood Skin Sets

Set A = Three 12"H Skins and One 24"H Skin

24"	TS76624AWSF	\$2449	+\$325	+\$325	+\$1137
30"	TS76630AWSF	\$2617	+\$325	+\$325	+\$1137
36"	TS76636AWSF	\$2783	+\$379	+\$379	+\$1331
42"	TS76642AWSF	\$2958	+\$379	+\$379	+\$1331
48"	TS76648AWSF	\$3142	+\$379	+\$379	+\$1331

► Specification Information, continued on next page

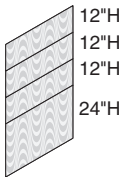
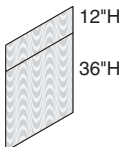
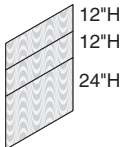
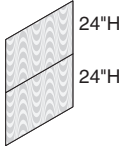

For Canadian Pricing
 Multiply U.S. Price by the Canadian price factor.
 ► See page 1 for details.

Wood To The Floor Skin Sets, continued

► Specification Information, continued from previous page

Specification Information					
Width	Style Number	U.S. Base Price	Options (Add \$ to Base Price)		
			Composite Veneer Group 2	Wood Group 2	Wood Group 3

66"H Wood Skin Sets, continued

Set B = One 12"H Skin and Two 24"H Skins

Width	Style Number	U.S. Base Price	Composite Veneer Group 2	Wood Group 2	Wood Group 3
24"	TS76624BWSF	\$2060	+\$242	+\$242	+\$ 852
30"	TS76630BWSF	\$2182	+\$242	+\$242	+\$ 852
36"	TS76636BWSF	\$2314	+\$360	+\$360	+\$1256
42"	TS76642BWSF	\$2455	+\$360	+\$360	+\$1256
48"	TS76648BWSF	\$2602	+\$360	+\$360	+\$1256

Set C = Two 12"H Skins and One 36"H Skin

Width	Style Number	U.S. Base Price	Composite Veneer Group 2	Wood Group 2	Wood Group 3
24"	TS76624CWSF	\$2131	+\$303	+\$303	+\$1057
30"	TS76630CWSF	\$2261	+\$303	+\$303	+\$1057
36"	TS76636CWSF	\$2398	+\$303	+\$303	+\$1057
42"	TS76642CWSF	\$2539	+\$365	+\$365	+\$1275
48"	TS76648CWSF	\$2729	+\$365	+\$365	+\$1275

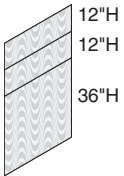
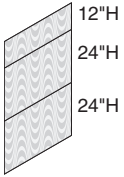

For Canadian Pricing

Multiply U.S. Price by the Canadian price factor.

► See page 1 for details.

Back Painted Glass Skins

Standard Includes		Required to Specify
<ul style="list-style-type: none"> ▶ Need help? Product details, page 131 	<ul style="list-style-type: none"> • Skin: back painted glass • Trim: paint • Attachment hardware 	<ol style="list-style-type: none"> 1 Style number 2 Back painted glass color for skin surface 3 Paint color number for trim 4 Options, if selected (see below) <ul style="list-style-type: none"> ▶ See <i>Surface Materials</i>, page 668.

Tip: Rare earth magnets should be used with magnetic backer.

Options	U.S. Price	Required to Specify
Magnetic Backer <ul style="list-style-type: none"> • Magnetic backer 	Prices below and at right	Specify with backer.

Specification Information

Tip: Back painted glass skins only work on junctions manufactured on or after October 10, 2011.

Tip: Back painted glass skins do not attach to wall start junctions.

12"H				18"H			
Dimensions W	Style Number	U.S. Base Price	Option (Add \$ to Base Price)	Dimensions W	Style Number	U.S. Base Price	Option (Add \$ to Base Price)
			Magnetic Backer				Magnetic Backer
18"	TS71218GS	\$ 763	+\$ 320	18"	TS71818GS	\$ 850	+\$ 359
24"	TS71224GS	\$ 844	+\$ 358	24"	TS71824GS	\$ 980	+\$ 413
30"	TS71230GS	\$ 935	+\$ 393	30"	TS71830GS	\$1105	+\$ 469
36"	TS71236GS	\$1068	+\$ 449	36"	TS71836GS	\$1284	+\$ 541
42"	TS71242GS	\$1225	+\$ 518	42"	TS71842GS	\$1494	+\$ 630
48"	TS71248GS	\$1310	+\$ 550	48"	TS71848GS	\$1615	+\$ 680
60"	TS71260GS	\$1561	+\$ 657	60"	TS71860GS	\$1958	+\$ 826
72"	TS71272GS	\$1778	+\$ 749	72"	TS71872GS	\$2250	+\$ 948

24"H				30"H			
Dimensions W	Style Number	U.S. Base Price	Option (Add \$ to Base Price)	Dimensions W	Style Number	U.S. Base Price	Option (Add \$ to Base Price)
18"	TS72418GS	\$ 944	+\$ 399	18"	TS73018GS	\$1040	+\$ 437
24"	TS72424GS	\$1111	+\$ 470	24"	TS73024GS	\$1246	+\$ 525
30"	TS72430GS	\$1283	+\$ 541	30"	TS73030GS	\$1456	+\$ 614
36"	TS72436GS	\$1501	+\$ 631	36"	TS73036GS	\$1713	+\$ 724
42"	TS72442GS	\$1765	+\$ 741	42"	TS73042GS	\$2034	+\$ 857
48"	TS72448GS	\$1922	+\$ 810	48"	TS73048GS	\$2228	+\$ 940
60"	TS72460GS	\$2353	+\$ 992	60"	TS73060GS	\$2750	+\$1159
72"	TS72472GS	\$2725	+\$1147	72"	TS73072GS	\$3197	+\$1347

▶ Specification Information, continued on next page



For Canadian Pricing
 Multiply U.S. Price by the Canadian price factor.
 ▶ See page 1 for details.

► Specification Information, continued from previous page

Specification Information

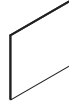

36"H

Dimensions W	Style Number	U.S. Base Price	Option (Add \$ to Base Price) Magnetic Backer
18"	TS73618GS	\$1131	+\$ 476
24"	TS73624GS	\$1382	+\$ 583
30"	TS73630GS	\$1628	+\$ 688
36"	TS73636GS	\$1931	+\$ 814
42"	TS73642GS	\$2301	+\$ 970
48"	TS73648GS	\$2534	+\$1068
60"	TS73660GS	\$3144	+\$1327
72"	TS73672GS	\$3669	+\$1547



For Canadian Pricing

Multiply U.S. Price by the Canadian price factor.

► See page 1 for details.

Back Painted Glass To The Floor Skins

Tip: When specifying skins, the total skin height will be 6" less than the panel height. Skins to the floor are indicated by an F suffix. Plan 6" shorter than panel height, but skins to the floor are taller in actual height to cover the base trim area.

Tip: Rare earth magnets should be used with magnetic backer.

Tip: Remember to omit base trim(s) on horizontal frame package when using a skin to the floor.

Tip: Back painted glass skins only work on junctions manufactured on or after October 10, 2011.

Standard Includes		Required to Specify
▶ Need help? Product details, page 131	<ul style="list-style-type: none"> • Skin: back painted glass • Trim: paint • Attachment hardware 	1 Style number 2 Back painted glass color for skin surface 3 Paint color number for trim 4 Options, if selected (see below) ▶ See <i>Surface Materials</i> , page 668.

Options	U.S. Price	Required to Specify
Magnetic Backer • Magnetic backer	Prices below	Specify with backer.

Specification Information

24"H				30"H			
• Dimensions	• Style Number	• U.S. Base Price	• Option (Add \$ to Base Price)	• Dimensions	• Style Number	• U.S. Base Price	• Option (Add \$ to Base Price)
W			Magnetic Backer	W			Magnetic Backer
18"	TS72418GSF	\$1028	+\$ 433	18"	TS73018GSF	\$1130	+\$ 476
24"	TS72424GSF	\$1212	+\$ 513	24"	TS73024GSF	\$1357	+\$ 574
30"	TS72430GSF	\$1396	+\$ 588	30"	TS73030GSF	\$1588	+\$ 668
36"	TS72436GSF	\$1635	+\$ 689	36"	TS73036GSF	\$1872	+\$ 790
42"	TS72442GSF	\$1923	+\$ 812	42"	TS73042GSF	\$2218	+\$ 936
48"	TS72448GSF	\$2095	+\$ 883	48"	TS73048GSF	\$2429	+\$1022
60"	TS72460GSF	\$2564	+\$1081	60"	TS73060GSF	\$2998	+\$1264
72"	TS72472GSF	\$2969	+\$1252	72"	TS73072GSF	\$3485	+\$1468

36"H			
• Dimensions	• Style Number	• U.S. Base Price	• Option (Add \$ to Base Price)
18"	TS73618GSF	\$1234	+\$ 520
24"	TS73624GSF	\$1504	+\$ 633
30"	TS73630GSF	\$1778	+\$ 749
36"	TS73636GSF	\$2107	+\$ 887
42"	TS73642GSF	\$2509	+\$1056
48"	TS73648GSF	\$2759	+\$1164
60"	TS73660GSF	\$3428	+\$1444
72"	TS73672GSF	\$3999	+\$1684



For Canadian Pricing
 Multiply U.S. Price by the Canadian price factor.
 ▶ See page 1 for details.

Back Painted Glass
To The Floor Skins

Steel Technology Skins

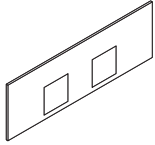

Tip: Remember to order technology covers to fill the cutouts. Only TS7TSCOVER style covers can be used with this skin.

Tip: A modular powerkit must always be located behind the technology skin.

Tip: 72"W technology skins accommodate fabric in the horizontal application only.

Tip: Ribbed steel technology skins cannot be fabric covered.

Tip: For further information about fabric direction, see page 674.

Tip: Technology skins are available with all cutouts or handed cutouts on just the right side or just the left side of the skin.

Standard Includes	Required to Specify
<ul style="list-style-type: none"> ▶ Need help? Product details, page 132 • Technology skin: paint price group 1 	<ol style="list-style-type: none"> 1 Style number 2 Paint color number for skin surface 3 Options, if selected (see below) <ul style="list-style-type: none"> ▶ See <i>Surface Materials</i>, page 668.

Surface Materials	Options	U.S. Price	Required to Specify
	Paint		
	• Paint price group 1	No cost	Specify paint color number.
	• Paint price group 2	+\$ 35	Specify paint color number.
	• Paint price group 3	+\$ 59	Specify paint color number.
	Fabric		
	• Fabric on steel technology skins	+\$ 75 plus the cost of fabric price group	Specify <i>with fabric</i> .
	• Fabric price group 1	No cost	Specify fabric color number.
	• Fabric price group 2	+\$ 21	Specify fabric color number.
	• Fabric price group 3	+\$ 39	Specify fabric color number.
	• Fabric price group 4	+\$ 57	Specify fabric color number.
• Fabric price group 5	+\$ 87	Specify fabric color number.	
• Fabric price group 6	+\$120	Specify fabric color number.	
• Fabric price group 7	+\$155	Specify fabric color number.	
• Fabric price group COM	+\$ 23	Specify fabric color number.	
	Ribbed steel		
	• Ribbed steel on 12"H and 18"H skins only	+\$ 33	Specify <i>with ribbed steel</i> .
	Fabric direction		
	• Horizontal application (standard)	No cost	Specify <i>with horizontal application</i> .
	• Vertical application	No cost	Specify <i>with vertical application</i> .



For Canadian Pricing

Multiply U.S. Price by the Canadian price factor.

▶ See page 1 for details.

Specification Information								
All Cutouts			Right Hand Cutout Only		Left Hand Cutout Only		No Cutouts	
Width	Style Number	U.S. Base Price	Style Number	U.S. Base Price	Style Number	U.S. Base Price	Style Number	U.S. Base Price

Tip: 6"H technology skins with cutouts includes a pair of powerkit brackets that attach the powerkit to the junction to correctly position it within the panel.

Tip: 6"H technology skin can only attach to junctions manufactured on or after October 10, 2011.

Tip: When using technology skin on one side of the panel (only used at worksurface height) a 12" or 18" skin can not be used on the opposite side of the panel at the same location as the 6"H skin.

6"H Steel Technology Skins

24"	TS7624TSS	\$113					TS7624HS	\$ 83
30"	TS7630TSS	\$140	TS7630RTSS	\$112	TS7630LTSS	\$112	TS7630HS	\$ 88
36"	TS7636TSS	\$146	TS7636RTSS	\$119	TS7636LTSS	\$119	TS7636HS	\$ 98
42"	TS7642TSS	\$149	TS7642RTSS	\$124	TS7642LTSS	\$124	TS7642HS	\$104
48"	TS7648TSS	\$165	TS7648RTSS	\$141	TS7648LTSS	\$141	TS7648HS	\$113
60"	TS7660TSS	\$189	TS7660RTSS	\$165	TS7660LTSS	\$165	TS7660HS	\$134
72"	TS7672TSS	\$208	TS7672RTSS	\$183	TS7672LTSS	\$183	TS7672HS	\$149

12"H Steel Technology Skins

24"	TS71224TSS	\$154						
30"	TS71230TSS	\$185	TS71230RTSS	\$159	TS71230LTSS	\$159		
36"	TS71236TSS	\$193	TS71236RTSS	\$169	TS71236LTSS	\$169		
42"	TS71242TSS	\$199	TS71242RTSS	\$174	TS71242LTSS	\$174		
48"	TS71248TSS	\$217	TS71248RTSS	\$193	TS71248LTSS	\$193		
60"	TS71260TSS	\$255	TS71260RTSS	\$227	TS71260LTSS	\$227		
72"	TS71272TSS	\$274	TS71272RTSS	\$252	TS71272LTSS	\$252		

18"H Steel Technology Skins

24"	TS71824TSS	\$196						
30"	TS71830TSS	\$231	TS71830RTSS	\$208	TS71830LTSS	\$208		
36"	TS71836TSS	\$247	TS71836RTSS	\$218	TS71836LTSS	\$218		
42"	TS71842TSS	\$257	TS71842RTSS	\$231	TS71842LTSS	\$231		
48"	TS71848TSS	\$278	TS71848RTSS	\$256	TS71848LTSS	\$256		
60"	TS71860TSS	\$315	TS71860RTSS	\$292	TS71860LTSS	\$292		
72"	TS71872TSS	\$352	TS71872RTSS	\$330	TS71872LTSS	\$330		

Tip: 18"H technology skin can only attach to junctions manufactured on or after October 10, 2011.

Tip: 18"H technology skins must be planned in 12"H increments from the bottom of the panel to align with powerkit locations.

For Canadian Pricing
 Multiply U.S. Price by the Canadian price factor.
 ▶ See page 1 for details.

Slatwall Technology Skins

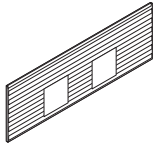

Tip: Remember to order technology covers to fill the cutouts. Only TS7TSCOVER style covers can be used with this skin.

Tip: A modular powerkit must always be located behind the technology skin.

Tip: Technology skins are available with all cutouts or handed cutouts on just the right side or just the left side of the skin.

Standard Includes		Required to Specify
▶ Need help? Product details, page 132	<ul style="list-style-type: none"> Technology skin with slatwall channels to accommodate worktools: paint Trim ring: painted steel 	1 Style number 2 Paint color number for skin surface and trim ring ▶ See <i>Surface Materials</i> , page 668.

Options	U.S. Price	Required to Specify
Surface Materials <ul style="list-style-type: none"> Paint price group 1 Paint price group 2 	No cost +\$35	Specify paint color number. Specify paint color number.

Specification Information						
All Cutouts			Right-Hand Cutout Only		Left-Hand Cutout Only	
Width	Style Number	U.S. Base Price	Style Number	U.S. Base Price	Style Number	U.S. Base Price
.....

12" Slatwall Technology Skins

24"	TS71224TSSW	\$402				
30"	TS71230TSSW	\$505	TS71230RTSSW	\$480	TS71230LTSSW	\$480
36"	TS71236TSSW	\$584	TS71236RTSSW	\$560	TS71236LTSSW	\$560
42"	TS71242TSSW	\$618	TS71242RTSSW	\$595	TS71242LTSSW	\$595
48"	TS71248TSSW	\$645	TS71248RTSSW	\$621	TS71248LTSSW	\$621
.....

18" Slatwall Technology Skins

24"	TS71824TSSW	\$500				
30"	TS71830TSSW	\$607	TS71830RTSSW	\$582	TS71830LTSSW	\$582
36"	TS71836TSSW	\$690	TS71836RTSSW	\$667	TS71836LTSSW	\$667
42"	TS71842TSSW	\$719	TS71842RTSSW	\$692	TS71842LTSSW	\$692
48"	TS71848TSSW	\$752	TS71848RTSSW	\$725	TS71848LTSSW	\$725
.....

Tip: 18"H technology skin can only attach to junctions manufactured on or after October 10, 2011.

Tip: Slatwall skins cannot be used in the bottom 12" of an Answer panel.



For Canadian Pricing
 Multiply U.S. Price by the Canadian price factor.
 ▶ See page 1 for details.

Markerboard Technology Skins

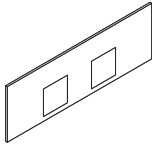

Tip: Remember to order technology covers to fill the cutouts. Only TS7TSCOVER style covers can be used with this skin.

Tip: A modular powerkit must always be located behind the technology skin.

Tip: Technology skins are available with all cutouts or handed cutouts on just the right side or just the left side of the skin.

Tip: 18"H technology skin can only attach to junctions manufactured on or after October 10, 2011.

Standard Includes		Required to Specify
▶ Need help? Product details, page 132	• Markerboard skin: white	Style number

Specification Information						
All Cutouts			Right-Hand Cutout Only		Left-Hand Cutout Only	
Width	Style Number	U.S. Price	Style Number	U.S. Price	Style Number	U.S. Price
:	:	:	:	:	:	:

12"H Markerboard Technology Skins

24"	TS71224TSMB	\$277				
30"	TS71230TSMB	\$343	TS71230RTSMB	\$319	TS71230LTSMB	\$319
36"	TS71236TSMB	\$359	TS71236RTSMB	\$334	TS71236LTSMB	\$334
42"	TS71242TSMB	\$373	TS71242RTSMB	\$350	TS71242LTSMB	\$350
48"	TS71248TSMB	\$395	TS71248RTSMB	\$370	TS71248LTSMB	\$370
:	:	:	:	:	:	:

18"H Markerboard Technology Skins

24"	TS71824TSMB	\$336				
30"	TS71830TSMB	\$404	TS71830RTSMB	\$380	TS71830LTSMB	\$380
36"	TS71836TSMB	\$425	TS71836RTSMB	\$399	TS71836LTSMB	\$399
42"	TS71842TSMB	\$444	TS71842RTSMB	\$419	TS71842LTSMB	\$419
48"	TS71848TSMB	\$464	TS71848RTSMB	\$443	TS71848LTSMB	\$443
:	:	:	:	:	:	:



For Canadian Pricing

Multiply U.S. Price by the Canadian price factor.

▶ See page 1 for details.

Technology Skin Cover and Fillers

Technology Skin Cover



Tip: Receptacle filler to close unused openings is available through Service Parts (891700204MP, package of 20).

Standard Includes		Required to Specify
<ul style="list-style-type: none"> ▶ Need help? Product details, page 133 	<ul style="list-style-type: none"> • Technology skin cover: plastic 	<ul style="list-style-type: none"> 1 Style number 2 Plastic color number for technology skin cover: <ul style="list-style-type: none"> 6000 Black 6009 Arctic White 6249 Platinum Solid 6654 Sand 6697 Fog
Specification Information		
Style Number	U.S. Price	
TS7TSCOVER	\$12	

Technology Skin Cover Fillers

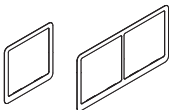

Tip: Technology skin cover filler is required when using a TS7TSCOVER technology skin cover on skins manufactured before November 21, 2011.

Tip: This technology skin cover filler is also included as standard with slatwall technology skins and can be used for replacement part needs on that skin as well.

Standard Includes		Required to Specify
<ul style="list-style-type: none"> ▶ Need help? Product details, page 133 	<ul style="list-style-type: none"> • Technology skin cover filler: paint 	<ul style="list-style-type: none"> 1 Style number 2 Paint color number for filler ▶ See <i>Surface Materials</i>, page 668.
Specification Information		
Style Number	Description	U.S. Price
TS7TSCFS	Single cutout	\$5
TS7TSCFD	Double cutout	\$5



For Canadian Pricing
 Multiply U.S. Price by the Canadian price factor.
 ▶ See page 1 for details.

Glass Windows

For Panel Buildups



Tip: Remember to specify spanning window in-line supports if window is spanning two or more panels.

Tip: When specifying a window span over two or more panels, it is recommended that the same size spanning top cap also be specified for use with the window.

Tip: When ordering a 72"W or wider single pane window kit to be used with steel or fabric skins located directly below it, two clips (890146001SR) should be ordered and installed.

Standard Includes		Required to Specify
▶ Need help? Product details, page 134	<ul style="list-style-type: none"> • Single-pane glass window, if selected: 6500 Clear Glass • Frame: paint 	1 Style number 2 Paint color number for frame 3 Options, if selected (see below) ▶ See <i>Surface Materials</i> , page 668.

Options	U.S. Price	Required to Specify
Surface Materials Frame <ul style="list-style-type: none"> • Paint price group 1 • Paint price group 2 • Paint price group 3 	No cost +\$ 35 +\$ 59	Specify paint color number. Specify paint color number. Specify paint color number.
Glass window <ul style="list-style-type: none"> • Frosted glass in 12"H window • Frosted glass in 18"H window • Frosted glass in 24"H window 	+\$ 85 +\$129 +\$168	Specify with 6530 Frosted Glass. Specify with 6530 Frosted Glass. Specify with 6530 Frosted Glass.

Specification Information						
12"H		18"H		24"H		
						
• Width	• Style Number	• U.S. Base Price	• Style Number	• U.S. Base Price	• Style Number	• U.S. Base Price
.....

Single Pane

24"	TS71224SPW	\$ 650	TS71824SPW	\$ 761	TS72424SPW	\$ 868
30"	TS71230SPW	\$ 695	TS71830SPW	\$ 812	TS72430SPW	\$ 918
36"	TS71236SPW	\$ 750	TS71836SPW	\$ 861	TS72436SPW	\$ 974
42"	TS71242SPW	\$ 801	TS71842SPW	\$ 917	TS72442SPW	\$1029
48"	TS71248SPW	\$ 844	TS71848SPW	\$ 985	TS72448SPW	\$1128
60"	TS71260SPW	\$ 979	TS71860SPW	\$1118	TS72460SPW	\$1257
72"	TS71272SPW	\$1092	TS71872SPW	\$1260	TS72472SPW	\$1432
78"	TS71278SPW	\$1248	TS71878SPW	\$1409	TS72478SPW	\$1571
84"	TS71284SPW	\$1371	TS71884SPW	\$1541	TS72484SPW	\$1711
90"	TS71290SPW	\$1493	TS71890SPW	\$1670	TS72490SPW	\$1849
96"	TS71296SPW	\$1611	TS71896SPW	\$1803	TS72496SPW	\$1987
.....

For Canadian Pricing
 Multiply U.S. Price by the Canadian price factor.
 ▶ See page 1 for details.

Single-Pane Glass Window Kits for Use with Custom Glass

For Panel Buildups

Tip: Custom glass must be ordered separately.
▶ See page 135 for the dimensions of custom inserts.

Tip: Glass window kits are available for single pane only.

Tip: Remember to specify spanning window in-line supports if window is spanning two or more panels.

Tip: When specifying a window to span over two or more panels, it is recommended that the same size spanning top cap also be specified for use with the window.

Tip: When ordering a 72"W or wider single pane window kit to be used with steel or fabric skins located directly below it, two clips (890146001SR) should be ordered and installed on the top edge of the skins.

Standard Includes		Required to Specify
▶ Need help? Product details, page 134	• Frame: paint	1 Style number 2 Paint color number for frame 3 Options, if selected (see below) ▶ See <i>Surface Materials</i> , page 668.

Options	U.S. Price	Required to Specify
Surface Materials	• Paint price group 1 • Paint price group 2 • Paint price group 3	No cost +\$35 +\$59

Specification Information						
12"H			18"H		24"H	
Width	Style Number	U.S. Base Price	Style Number	U.S. Base Price	Style Number	U.S. Base Price

Single Pane

24"	TS71224SCW	\$ 506	TS71824SCW	\$ 594	TS72424SCW	\$ 678
30"	TS71230SCW	\$ 546	TS71830SCW	\$ 630	TS72430SCW	\$ 716
36"	TS71236SCW	\$ 580	TS71836SCW	\$ 671	TS72436SCW	\$ 761
42"	TS71242SCW	\$ 621	TS71842SCW	\$ 714	TS72442SCW	\$ 806
48"	TS71248SCW	\$ 656	TS71848SCW	\$ 766	TS72448SCW	\$ 875
60"	TS71260SCW	\$ 770	TS71860SCW	\$ 873	TS72460SCW	\$ 974
72"	TS71272SCW	\$ 862	TS71872SCW	\$ 990	TS72472SCW	\$1112
78"	TS71278SCW	\$ 973	TS71878SCW	\$1099	TS72478SCW	\$1226
84"	TS71284SCW	\$1070	TS71884SCW	\$1199	TS72484SCW	\$1334
90"	TS71290SCW	\$1163	TS71890SCW	\$1304	TS72490SCW	\$1442
96"	TS71296SCW	\$1258	TS71896SCW	\$1407	TS72496SCW	\$1554



For Canadian Pricing
Multiply U.S. Price by the Canadian price factor.
▶ See page 1 for details.

Spanning Window In-Line Support and In-Line Spanning Top Cap Lightseal

Spanning Window In-Line Support and In-Line Spanning Top Cap Lightseal

Spanning Window In-Line Support

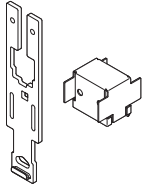

Tip: Spanning window in-line support is needed when spanning a single window across two or more panels. Specify one support for each in-line junction window spans.

Standard Includes	Required to Specify
<ul style="list-style-type: none"> Need help? Product details, page 135 Spanning window in-line support: black 	Style number

Specification Information	
Style Number	U.S. Price
TS7SWS	\$72

In-Line Spanning Top Cap Lightseal



Tip: These lightseals are only needed when spanning two or more panels with a single top cap or frameless glass screen.

Standard Includes	Required to Specify
<ul style="list-style-type: none"> Need help? Product details, page 109 In-line top cap lightseal: black 	Style number

Specification Information		
Style Number	Quantity	U.S. Price
TS7STLS1	1	\$ 25
TS7STLS10	10	\$250



For Canadian Pricing
 Multiply U.S. Price by the Canadian price factor.
 ▶ See page 1 for details.

Sliding Panel Doors

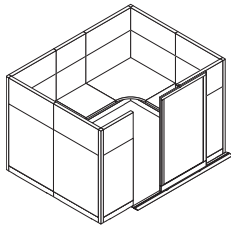

Tip: The sliding door is located outside of the panel system when installed in the standard position.

Tip: Door infill is standard in ribbed translucent plastic.

Tip: The standard door is handed and non-locking. When a lock option is specified, the lock will be on the trail end of the door. The illustration above shows a left-handed sliding door. If a lock option is specified, the lock will be on the right (trail) side of the door.

Tip: Width of host panel should always be equal to the width of sliding door.

Tip: Height of host and receiving panels must match height of door.

Tip: Remember to specify lock cylinder and key.
▶ Lock Cylinders, page 686.

Tip: When attaching the sliding door to an Answer panel, a junction stabilizer bracket is available for added rigidity to the host panel. If a host and/or receiving panel run exceeds 4', a junction stabilizer bracket must be applied to the door end of the host and/or receiving panel run. On long runs, apply a junction stabilizer bracket or perpendicular panel every 8'.
▶ Page 411

Standard Includes	Required to Specify
<ul style="list-style-type: none"> ▶ Need help? Product details, page 136 • Panel door frame and door track: paint price group 1 • Panel door infill: 6625 Translucent plastic • Floor track • Attachment bracket 	<ol style="list-style-type: none"> 1 Style number 2 Paint color number for panel door frame, door track, floor track, and attachment bracket 3 Options, if selected (see below) <p>▶ See <i>Surface Materials</i>, page 668.</p>

Options	U.S. Price	Required to Specify
Surface Materials <ul style="list-style-type: none"> • Paint price group 1 • Paint price group 2 	No cost +\$ 16	Specify paint color number. Specify paint color number.
Door Hand <ul style="list-style-type: none"> • Left-hand sliding door • Right-hand sliding door 	No cost No cost	Specify <i>with left-hand door</i> . Specify <i>with right-hand door</i> .
Door panel <ul style="list-style-type: none"> • 6500 Clear tempered glass • 6541 White laminated glass 	+\$379 +\$594	Specify <i>with 6500 Clear glass</i> . Specify <i>with 6541 White laminated glass</i> .
Door Lock <ul style="list-style-type: none"> • Lock 	+\$492	Specify <i>with lock</i> . ▶ See Lock and Keying, page 686.

Specification Information				
• Dimensions			• Style	• U.S.
D	W	H	Number	Base Price
1¼"	36"	66"	TSAPDSA6636	\$3647
1¼"	42"	66"	TSAPDSA6642	\$3863
1¼"	36"	78"	TSAPDSA7836	\$3974
1¼"	42"	78"	TSAPDSA7842	\$4185
:	:	:	:	:



For Canadian Pricing
Multiply U.S. Price by the Canadian price factor.
▶ See page 1 for details.

Hardwire Base Trim

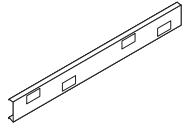

Standard Includes	Required to Specify
-------------------	---------------------

- | | |
|-------------------------------------------------------------------------------------------------------------|-------------------------------------------------------------------------------------------------------------------------------------------------------------|
| <ul style="list-style-type: none"> • Base trim with knockouts for hardwired power kit: paint | <ul style="list-style-type: none"> 1 Style number 2 Paint color number from trim ▶ See <i>Surface Materials</i>, page 668. |
|-------------------------------------------------------------------------------------------------------------|-------------------------------------------------------------------------------------------------------------------------------------------------------------|

Specification Information		
Width	Style Number	U.S. Price

24"	TS724BTH	\$29
30"	TS730BTH	\$32
36"	TS736BTH	\$34
42"	TS742BTH	\$35
48"	TS748BTH	\$36
60"	TS760BTH	\$44
72"	TS772BTH	\$47

Shared Components

 **For Canadian Pricing**
 Multiply U.S. Price by the Canadian price factor.
 ▶ See page 1 for details.

Panel and Beam Foot

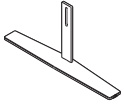

Standard Includes		Required to Specify
<ul style="list-style-type: none"> ▶ Need help? Product details, page 138 	<ul style="list-style-type: none"> • Panel and beam foot: paint price group 1 • Attachment hardware 	<ul style="list-style-type: none"> 1 Style number 2 Paint color number for panel and beam foot ▶ See <i>Surface Materials</i>, page 668.

Options	U.S. Price	Required to Specify
Surface Materials <ul style="list-style-type: none"> • Paint price group 1 • Paint price group 2 • Paint price group 3 	<ul style="list-style-type: none"> No cost +\$16 +\$34 	<ul style="list-style-type: none"> Specify paint color number. Specify paint color number. Specify paint color number.

Specification Information	
Style Number	U.S. Base Price
TS7PF	\$380



For Canadian Pricing
 Multiply U.S. Price by the Canadian price factor.
 ▶ See page 1 for details.

Wiring and Cabling

Cable Trays

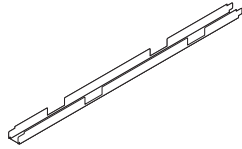

Tip: Cables may also be routed in top of powerkit.

Tip: One cable tray can be optioned at no cost when ordering base horizontal frame or panel packages.

Tip: Cable carriers can be added to 24"-72" wide trays.
 ▶ See *Montage Specification Guide* for style number ZCC.

Standard Includes	Required to Specify
▶ Need help? Product details, page 176 • Cable tray: black paint only	Style number

Specification Information			
Dimensions		Style	U.S.
W	H	Number	Price
18"	2"	TS718CT	\$ 36
24"	2"	TS724CT	\$ 46
30"	2"	TS730CT	\$ 48
36"	2"	TS736CT	\$ 60
42"	2"	TS742CT	\$ 64
48"	2"	TS748CT	\$ 76
60"	2"	TS760CT	\$ 85
72"	2"	TS772CT	\$104
:	:	:	:

Shared Components

 **For Canadian Pricing**
 Multiply U.S. Price by the Canadian price factor.
 ▶ See page 1 for details.

Wiring and Cabling, continued

Powerkits

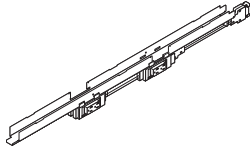

Tip: Remember to order receptacles and faceplates.
 ▶ Pages 484 and 486

Standard Includes	Required to Specify
▶ Need help? Product details, page 176 • Powerkit to accommodate modular duplex and USB receptacles on both sides: black plastic • Supporting powertray: black paint • Harness with modular connectors	Style number

Specification Information

Powerkits			Non-PVC Powerkits		
Width	Number of Duplex Receptacles Per Side	Style Number	U.S. Price	Style Number	U.S. Price

4-Circuit, 3+1 Wiring Schematic

24"	1	TS7PK24X	\$311	TS7PK24XN	\$327
30"	2	TS7PK30X	\$311	TS7PK30XN	\$327
36"	2	TS7PK36X	\$311	TS7PK36XN	\$327
42"	2	TS7PK42X	\$311	TS7PK42XN	\$327
48"	2	TS7PK48X	\$311	TS7PK48XN	\$327
60"	4	TS7PK60X	\$470	TS7PK60XN	\$486
72"	4	TS7PK72X	\$470	TS7PK72XN	\$486
:	:	:	:	:	:

4-Circuit, 2+2 Wiring Schematic

24"	1	TS7PK24Y	\$311	TS7PK24YN	\$327
30"	2	TS7PK30Y	\$311	TS7PK30YN	\$327
36"	2	TS7PK36Y	\$311	TS7PK36YN	\$327
42"	2	TS7PK42Y	\$311	TS7PK42YN	\$327
48"	2	TS7PK48Y	\$311	TS7PK48YN	\$327
60"	4	TS7PK60Y	\$470	TS7PK60YN	\$486
72"	4	TS7PK72Y	\$470	TS7PK72YN	\$486
:	:	:	:	:	:

3-Circuit, Separate Neutrals (3SN) Wiring Schematic

24"	1	TS7PK24Z	\$311	TS7PK24ZN	\$327
30"	2	TS7PK30Z	\$311	TS7PK30ZN	\$327
36"	2	TS7PK36Z	\$311	TS7PK36ZN	\$327
42"	2	TS7PK42Z	\$311	TS7PK42ZN	\$327
48"	2	TS7PK48Z	\$311	TS7PK48ZN	\$327
60"	4	TS7PK60Z	\$470	TS7PK60ZN	\$486
72"	4	TS7PK72Z	\$470	TS7PK72ZN	\$486
:	:	:	:	:	:



For Canadian Pricing
 Multiply U.S. Price by the Canadian price factor.
 ▶ See page 1 for details.

Pass-Through Powerkits

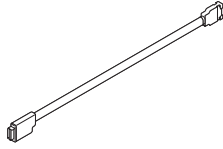

Standard Includes	Required to Specify
<ul style="list-style-type: none"> ▶ Need help? Product details, page 176 • Powerkit to accommodate modular receptacles on both sides: black plastic • Supporting powertray: black paint • Harness with modular connectors 	Style number

Specification Information

Pass-Through Powerkits			Non-PVC Pass-Through Powerkits		
Width	Number of Duplex Receptacles Per Side	Style Number	U.S. Price	Style Number	U.S. Price

4-Circuit, 3+1 Wiring Schematic

18"	0	TS7PT18X	\$250	TS7PT18XN	\$264
24"	0	TS7PT24X	\$250	TS7PT24XN	\$264
30"	0	TS7PT30X	\$250	TS7PT30XN	\$264
36"	0	TS7PT36X	\$250	TS7PT36XN	\$264
42"	0	TS7PT42X	\$250	TS7PT42XN	\$264
48"	0	TS7PT48X	\$250	TS7PT48XN	\$264
60"	0	TS7PT60X	\$279	TS7PT60XN	\$295
72"	0	TS7PT72X	\$279	TS7PT72XN	\$295
.

4-Circuit, 2+2 Wiring Schematic

18"	0	TS7PT18Y	\$250	TS7PT18YN	\$264
24"	0	TS7PT24Y	\$250	TS7PT24YN	\$264
30"	0	TS7PT30Y	\$250	TS7PT30YN	\$264
36"	0	TS7PT36Y	\$250	TS7PT36YN	\$264
42"	0	TS7PT42Y	\$250	TS7PT42YN	\$264
48"	0	TS7PT48Y	\$250	TS7PT48YN	\$264
60"	0	TS7PT60Y	\$279	TS7PT60YN	\$295
72"	0	TS7PT72Y	\$279	TS7PT72YN	\$295
.

3-Circuit, Separate Neutrals (3SN) Wiring Schematic

18"	0	TS7PT18Z	\$250	TS7PT18ZN	\$264
24"	0	TS7PT24Z	\$250	TS7PT24ZN	\$264
30"	0	TS7PT30Z	\$250	TS7PT30ZN	\$264
36"	0	TS7PT36Z	\$250	TS7PT36ZN	\$264
42"	0	TS7PT42Z	\$250	TS7PT42ZN	\$264
48"	0	TS7PT48Z	\$250	TS7PT48ZN	\$264
60"	0	TS7PT60Z	\$279	TS7PT60ZN	\$295
72"	0	TS7PT72Z	\$279	TS7PT72ZN	\$295
.

For Canadian Pricing
 Multiply U.S. Price by the Canadian price factor.
 ▶ See page 1 for details.

Wiring and Cabling, continued

Duplex Receptacles

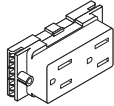

Standard Includes	Required to Specify
-------------------	---------------------

<ul style="list-style-type: none"> ▶ Need help? Product details, page 181 • Receptacle: plastic 	<ul style="list-style-type: none"> 1 Style number 2 Plastic color number for receptacle: <ul style="list-style-type: none"> 6000 Black 6009 Arctic White 6249 Platinum Solid 6651 Tungsten 6652 Titanium 6654 Sand 6697 Fog 6B03 Red 3 Options, if selected (see below)
-------------------------------------------------------------------------------------------------------------------------	---------------------------------------------------------------------------------------------------------------------------------------------------------------------------------------------------------------------------------------------------------------------------------------------------------------------------------------------------------------------------------------------------------------------

Options	U.S. Price	Required to Specify
---------	------------	---------------------

Controlled Stamp <ul style="list-style-type: none"> • No stamp • Controlled stamp 	No cost +\$5	Specify <i>with no stamp</i> . Specify <i>with controlled stamp</i> .
------------------------------------------------------------------------------------------------------------------	-----------------	--------------------------------------------------------------------------

Specification Information								
15-Amp Receptacles				20-Amp Receptacles				
Line	Style Number	U.S. Base Price	Style Number	U.S. Base Price	Style Number	U.S. Base Price	Style Number	U.S. Base Price

--	--	--	--	--	--	--	--	--

4-Circuit, 3+1 Wiring Schematic

	System Ground		Isolated Ground		System Ground		Isolated Ground	
Line 1	TS71SSX	\$63	TS71SGX	\$81	ZB1R1SGH	\$109	ZB1R1IGH	\$140
Line 2	TS72SSX	\$63	TS72SGX	\$81	ZB1R2SGH	\$109	ZB1R2IGH	\$140
Line 3	TS73SSX	\$63	TS73SGX	\$81	ZB1R3SGH	\$109	ZB1R3IGH	\$140
Line 4	TS74SSX	\$63	TS74SGX	\$81	ZB1R4SGH	\$109	ZB1R4IGH	\$140

4-Circuit, 2+2 Wiring Schematic

	System Ground		Isolated Ground		System Ground		Isolated Ground	
Line 1	TS71SSY	\$63	TS71SGY	\$81	ZB2R1SGH	\$109	ZB2R1IGH	\$140
Line 2	TS72SSY	\$63	TS72SGY	\$81	ZB2R2SGH	\$109	ZB2R2IGH	\$140
Line 3	TS73SSY	\$63	TS73SGY	\$81	ZB2R3SGH	\$109	ZB2R3IGH	\$140
Line 4	TS74SSY	\$63	TS74SGY	\$81	ZB2R4SGH	\$109	ZB2R4IGH	\$140

3-Circuit, Separate Neutrals (3SN) Wiring Schematic

	System Ground		Isolated Ground		System Ground		Isolated Ground	
Line 1	TS71SSZ	\$63	TS71SGZ	\$81	ZB3R1SGH	\$109	ZB3R1IGH	\$140
Line 2	TS72SSZ	\$63	TS72SGZ	\$81	ZB3R2SGH	\$109	ZB3R2IGH	\$140
Line 3	TS73SSZ	\$63	TS73SGZ	\$81	ZB3R3SGH	\$109	ZB3R3IGH	\$140



For Canadian Pricing
 Multiply U.S. Price by the Canadian price factor.
 ▶ See page 1 for details.

USB Receptacles

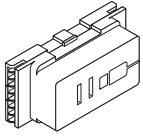

Standard Includes	Required to Specify
<ul style="list-style-type: none"> Need help? Product details, page 181 USB receptacle: plastic 	<ul style="list-style-type: none"> 1 Style number 2 Plastic color number for USB receptacle: <ul style="list-style-type: none"> 6000 Black 6009 Arctic White 6249 Platinum Solid 6651 Tungsten 6652 Titanium 6654 Sand 6697 Fog 6B03 Red

Specification Information

Line	Style Number	U.S. Price

4-Circuit, 3+1 Wiring Schematic

Line 1	TS71USBX	\$159
Line 2	TS72USBX	\$159
Line 3	TS73USBX	\$159
Line 4	TS74USBX	\$159

4-Circuit, 2+2 Wiring Schematic

Line 1	TS71USBY	\$159
Line 2	TS72USBY	\$159
Line 3	TS73USBY	\$159
Line 4	TS74USBY	\$159

3-Circuit, Separate Neutrals (3SN) Wiring Schematic

Line 1	TS71USBZ	\$159
Line 2	TS72USBZ	\$159
Line 3	TS73USBZ	\$159

For Canadian Pricing
 Multiply U.S. Price by the Canadian price factor.
 ▶ See page 1 for details.

Wiring and Cabling, continued

Receptacles

For Use with Power Cutouts in Steel Skins

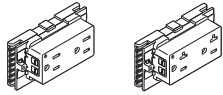

15 amp 20 amp

Tip: Specify when using steel skins with power cutouts.

Tip: For power access in steel skins with power cutouts, receptacle trim ring is required for each power cutout location specified (ordered separately).

Standard Includes	Required to Specify
-------------------	---------------------

- Receptacle: plastic

- 1 Style number
 - 2 Plastic color number for receptacle
 - 3 Wiring schematic (see below under Required Selections)
 - 4 Line (see below under Required Selections)
 - 5 Ground type (see below under Required Selections)
 - 6 Amp type (see below under Required Selections)
 - 7 Options, if selected (see below)
- ▶ See *Surface Materials*, page 668.

	Required Selections	U.S. Price	Required to Specify
--	---------------------	------------	---------------------

Wiring Schematic

- 3+1 No cost
- 2+2 No cost
- 3SN No cost

Specify with 3+1.
Specify with 2+2.
Specify with 3SN.

Line

- Line 1 No cost
- Line 2 No cost
- Line 3 No cost
- Line 4 No cost

Specify with line 1.
Specify with line 2.
Specify with line 3.
Specify with line 4.

Ground Type

- System No cost
- Isolated No cost

Specify with system ground.
Specify with isolated ground.

Amp Type

- 15 amp No cost
- 20 amp +\$35

Specify with 15 amp.
Specify with 20 amp.

	Options	U.S. Price	Required to Specify
--	---------	------------	---------------------

Controlled Stamp

- No stamp No cost
- Controlled stamp +\$ 5

Specify with no stamp.
Specify with controlled stamp.

Specification Information

• **Style Number**

• **U.S. Base Price**

TS7RC \$63

For Canadian Pricing
Multiply U.S. Price by the Canadian price factor.
▶ See page 1 for details.

USB Receptacles

For Use with Power Cutouts in Steel Skins



Tip: Specify when using steel skins with power cutouts.

Tip: For power access in steel skins with power cutouts, receptacle trim ring is required for each power cutout location specified (ordered separately).

Standard Includes	Required to Specify
<ul style="list-style-type: none"> USB receptacle: plastic 	<ol style="list-style-type: none"> Style number Plastic color number for receptacle Wiring schematic (see below under Required Selections) Line (see below under Required Selections) <p>▶ See <i>Surface Materials</i>, page 668.</p>

	Required Selections	U.S. Price	Required to Specify
Wiring Schematic	<ul style="list-style-type: none"> 3+1 2+2 3SN 	<p>No cost</p> <p>No cost</p> <p>No cost</p>	<p>Specify with 3+1.</p> <p>Specify with 2+2.</p> <p>Specify with 3SN.</p>
Line	<ul style="list-style-type: none"> Line 1 Line 2 Line 3 Line 4 (Available in 3+1 and 2+2 only) 	<p>No cost</p> <p>No cost</p> <p>No cost</p> <p>No cost</p>	<p>Specify with line 1.</p> <p>Specify with line 2.</p> <p>Specify with line 3.</p> <p>Specify with line 4.</p>

Specification Information	
Style Number	U.S. Price
TS7USB	\$150

Faceplate

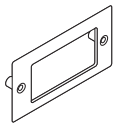

Standard Includes	Required to Specify
<p>▶ Need help? Product details, page 181</p> <ul style="list-style-type: none"> One faceplate: plastic Ordered individually 	<ol style="list-style-type: none"> Style number Plastic color number for faceplate: <ul style="list-style-type: none"> 6000 Black 6009 Arctic White 6249 Platinum Solid 6651 Tungsten 6652 Titanium 6654 Sand 6697 Fog 6B03 Red

Specification Information	
Style Number	U.S. Price
TS7UFPLATE	\$5

Faceplate for Duplex Receptacle and Communications

TS7UFPLATE	\$5
-------------------	-----



For Canadian Pricing
 Multiply U.S. Price by the Canadian price factor.
 ▶ See page 1 for details.

Wiring and Cabling, continued

Receptacle Trim Ring



Tip: Receptacle trim ring required for each power cut-out location on steel panel skins.

Standard Includes	Required to Specify
<ul style="list-style-type: none"> Receptacle trim ring: plastic 	<ul style="list-style-type: none"> 1 Style number 2 Plastic color number for receptacle trim ring ▶ See <i>Surface Materials</i>, page 668.

Specification Information	
• Style Number	• U.S. Price
TS7RCT	\$16

Receptacle Filler



Tip: Receptacle filler package fills unused receptacle openings in steel skins with power cutouts.

Standard Includes	Required to Specify
<ul style="list-style-type: none"> Package of 20 receptacle fillers: plastic 	<ul style="list-style-type: none"> 1 Style number 2 Plastic color number for receptacle fillers ▶ See <i>Surface Materials</i>, page 668.

Specification Information	
• Style Number	• U.S. Price
TSBRF	\$136

Data Filler



Tip: Data filler package fills unused data openings in steel skins with data cutouts.

Standard Includes	Required to Specify
<ul style="list-style-type: none"> Package of 20 data fillers: plastic 	<ul style="list-style-type: none"> 1 Style number 2 Plastic color number for data fillers ▶ See <i>Surface Materials</i>, page 668.

Specification Information	
• Style Number	• U.S. Price
TS7DF	\$112

For Canadian Pricing
 Multiply U.S. Price by the Canadian price factor.
 ▶ See page 1 for details.

Base Power Infeeds

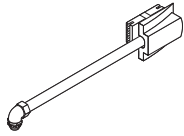

Tip: Power infeed occupies one receptacle location on powerkit.

Tip: Power infeed sits proud of the panel approximately 3" and will interfere with Universal storage with the Universal 3" base, FrameOne foot base, or c:scape glide.

Standard Includes		Required to Specify
▶ Need help? Product details, page 174	<ul style="list-style-type: none"> Power infeed cover: plastic 7/8"-diameter conduit: black plastic only 	1 Style number 2 Plastic color number for power infeed assembly cover: 6000 Black 6009 Arctic White 6249 Platinum Solid 6651 Tungsten 6652 Titanium 6654 Sand 6697 Fog 6B03 Red

Specification Information

Length	Style Number	U.S. Price
--------	--------------	------------

4-Circuit, 3+1 Wiring Schematic

6'	TS76BPX	\$388
12'	TS712BPX	\$415

For Use in San Francisco

6'	TS76BPSFX	\$388
12'	TS712BPSFX	\$415

4-Circuit, 2+2 Wiring Schematic

6'	TS76BPY	\$388
12'	TS712BPY	\$415

For Use in San Francisco

6'	TS76BPSFY	\$388
12'	TS712BPSFY	\$415

3-Circuit, Separate Neutrals (3SN) Wiring Schematic

6'	TS76BPZ	\$388
12'	TS712BPZ	\$415

For Use in San Francisco

6'	TS76BPSFZ	\$388
12'	TS712BPSFZ	\$415

 **For Canadian Pricing**
 Multiply U.S. Price by the Canadian price factor.
 ▶ See page 1 for details.

Wiring and Cabling, continued

Base Power Infeeds for Use in New York City



Tip: Power infeed sits proud of the panel approximately 3" and will interfere with Universal storage with the Universal 3" base, FrameOne foot base, or c:scape glide.

Standard Includes	Required to Specify
<ul style="list-style-type: none"> ▶ Need help? Product details, page 175 • Power infeed assembly • 1/2"-diameter conduit • Power infeed tray: black paint only • Power infeed cover: black paint only 	Style number

Specification Information

Corresponding Panel Width	Style Number	U.S. Price
4-Circuit, 3+1 Wiring Schematic		
24"	TS7BPNY24X	\$388
30"	TS7BPNY30X	\$388
36"	TS7BPNY36X	\$388
42"	TS7BPNY42X	\$388
48"	TS7BPNY48X	\$388
60"	TS7BPNY60X	\$388
72"	TS7BPNY72X	\$388

Corresponding Panel Width	Style Number	U.S. Price
Non-PVC		
4-Circuit, 3+1 Wiring Schematic		
24"	TS7BPNY24XN	\$404
30"	TS7BPNY30XN	\$404
36"	TS7BPNY36XN	\$404
42"	TS7BPNY42XN	\$404
48"	TS7BPNY48XN	\$404
60"	TS7BPNY60XN	\$404
72"	TS7BPNY72XN	\$404

Corresponding Panel Width	Style Number	U.S. Price
4-Circuit, 2+2 Wiring Schematic		
24"	TS7BPNY24Y	\$388
30"	TS7BPNY30Y	\$388
36"	TS7BPNY36Y	\$388
42"	TS7BPNY42Y	\$388
48"	TS7BPNY48Y	\$388
60"	TS7BPNY60Y	\$388
72"	TS7BPNY72Y	\$388

Corresponding Panel Width	Style Number	U.S. Price
4-Circuit, 2+2 Wiring Schematic		
24"	TS7BPNY24YN	\$404
30"	TS7BPNY30YN	\$404
36"	TS7BPNY36YN	\$404
42"	TS7BPNY42YN	\$404
48"	TS7BPNY48YN	\$404
60"	TS7BPNY60YN	\$404
72"	TS7BPNY72YN	\$404

Corresponding Panel Width	Style Number	U.S. Price
3-Circuit, Separate Neutrals (3SN) Wiring Schematic		
24"	TS7BPNY24Z	\$388
30"	TS7BPNY30Z	\$388
36"	TS7BPNY36Z	\$388
42"	TS7BPNY42Z	\$388
48"	TS7BPNY48Z	\$388
60"	TS7BPNY60Z	\$388
72"	TS7BPNY72Z	\$388

Corresponding Panel Width	Style Number	U.S. Price
3-Circuit, Separate Neutrals (3SN) Wiring Schematic		
24"	TS7BPNY24ZN	\$404
30"	TS7BPNY30ZN	\$404
36"	TS7BPNY36ZN	\$404
42"	TS7BPNY42ZN	\$404
48"	TS7BPNY48ZN	\$404
60"	TS7BPNY60ZN	\$404
72"	TS7BPNY72ZN	\$404

For Canadian Pricing
 Multiply U.S. Price by the Canadian price factor.
 ▶ See page 1 for details.

Hardwired Powerkits

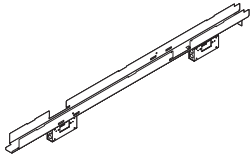

Tip: Specify hardwire base trims when accessing a hardwire powerkit in the base.

Standard Includes	Required to Specify
<ul style="list-style-type: none"> ▶ Need help? Product details, page 180 • Power tray • Junction box(es) • Cover plate(s) 	Style number

Specification Information			
Corresponding Panel Width	Number of Junction Boxes	Style Number	U.S. Price
24"	1	TS7CPK24	\$150
30"	2	TS7CPK30	\$150
36"	2	TS7CPK36	\$150
42"	2	TS7CPK42	\$150
48"	2	TS7CPK48	\$150
60"	2	TS7CPK60	\$189
72"	2	TS7CPK72	\$189
:	:	:	:

 **For Canadian Pricing**
 Multiply U.S. Price by the Canadian price factor.
 ▶ See page 1 for details.

Multipurpose Power Infeeds

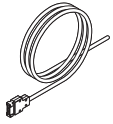

Tip: Utility poles must be specified separately.
▶ Page 419

Standard Includes	Required to Specify
<ul style="list-style-type: none"> ▶ Need help? Product details, page 178 • Multipurpose power infeed with modular connector • Insulated color-coded wires for hardwired connection to building power source 	Style number

Specification Information

Length	Style Number	U.S. Price
--------	--------------	------------

4-Circuit, 3+1 Wiring Schematic

6'	TS76UPHX	\$393
12'	TS712UPHX	\$506
24'	TS724UPHX	\$735
:	:	:

4-Circuit, 2+2 Wiring Schematic

6'	TS76UPHY	\$393
12'	TS712UPHY	\$506
24'	TS724UPHY	\$735
:	:	:

3-Circuit, Separate Neutrals (3SN) Wiring Schematic

6'	TS76UPHZ	\$393
12'	TS712UPHZ	\$506
24'	TS724UPHZ	\$735
:	:	:

Non-PVC

Length	Style Number	U.S. Price
--------	--------------	------------

4-Circuit, 3+1 Wiring Schematic

6'	TS76UPHXN	\$393
12'	TS712UPHXN	\$522
24'	TS724UPHXN	\$755
:	:	:

4-Circuit, 2+2 Wiring Schematic

6'	TS76UPHYN	\$393
12'	TS712UPHYN	\$522
24'	TS724UPHYN	\$755
:	:	:

3-Circuit, Separate Neutrals (3SN) Wiring Schematic

6'	TS76UPHZN	\$393
12'	TS712UPHZN	\$522
24'	TS724UPHZN	\$755
:	:	:



For Canadian Pricing
Multiply U.S. Price by the Canadian price factor.
▶ See page 1 for details.

Modular Harnesses

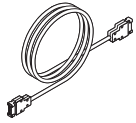

Standard Includes	Required to Specify
<ul style="list-style-type: none"> Need help? Product details, page 178 Conduit with two modular connectors: black 	<ul style="list-style-type: none"> Style number

Specification Information

Length	Style Number	U.S. Price
--------	--------------	------------

4-Circuit, 3+1 Wiring Schematic

43"	TS743MHX	\$226
80"	TS780MHX	\$300
:	:	:

4-Circuit, 2+2 Wiring Schematic

43"	TS743MHY	\$226
80"	TS780MHY	\$300
:	:	:

3-Circuit, Separate Neutrals (3SN) Wiring Schematic

43"	TS743MHZ	\$226
80"	TS780MHZ	\$300
:	:	:

Non-PVC

Length	Style Number	U.S. Price
--------	--------------	------------

4-Circuit, 3+1 Wiring Schematic

43"	TS743MHXN	\$242
80"	TS780MHXN	\$347
:	:	:

4-Circuit, 2+2 Wiring Schematic

43"	TS743MHYN	\$242
80"	TS780MHYN	\$347
:	:	:

3-Circuit, Separate Neutrals (3SN) Wiring Schematic

43"	TS743MHZN	\$242
80"	TS780MHZN	\$347
:	:	:



For Canadian Pricing
 Multiply U.S. Price by the Canadian price factor.
 ▶ See page 1 for details.

Modular Harnesses

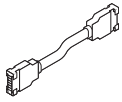

Tip: Remember to order connectors, which are required to connect two modular harnesses or to connect a modular harness to a hub harness.

▶ Page 496

Standard Includes	Required to Specify
▶ Need help? Product details, page 178 • Harness	Style number

Specification Information

			Non-PVC		
Length	Style Number	U.S. Price	Length	Style Number	U.S. Price
4-Circuit, 3+1					
12"	GSGUH12X	\$220	12"	GSGUH12XN	\$240
22"	GSGUH22X	\$220	22"	GSGUH22XN	\$240
28"	GSGUH28X	\$220	28"	GSGUH28XN	\$240
32"	GSGUH32X	\$220	32"	GSGUH32XN	\$240
38"	GSGUH38X	\$220	38"	GSGUH38XN	\$240
44"	GSGUH44X	\$252	44"	GSGUH44XN	\$271
50"	GSGUH50X	\$252	50"	GSGUH50XN	\$271
54"	GSGUH54X	\$266	54"	GSGUH54XN	\$281
64"	GSGUH64X	\$292	64"	GSGUH64XN	\$322
76"	GSGUH76X	\$319	76"	GSGUH76XN	\$347
88"	GSGUH88X	\$364	88"	GSGUH88XN	\$384
100"	GSGUH100X	\$393	100"	GSGUH100XN	\$413
120"	GSGUH120X	\$463	120"	GSGUH120XN	\$483
144"	GSGUH144X	\$525	144"	GSGUH144XN	\$547
4-Circuit, 2+2					
12"	GSGUH12Y	\$220	12"	GSGUH12YN	\$240
22"	GSGUH22Y	\$220	22"	GSGUH22YN	\$240
28"	GSGUH28Y	\$220	28"	GSGUH28YN	\$240
32"	GSGUH32Y	\$220	32"	GSGUH32YN	\$240
38"	GSGUH38Y	\$220	38"	GSGUH38YN	\$240
44"	GSGUH44Y	\$252	44"	GSGUH44YN	\$271
50"	GSGUH50Y	\$252	50"	GSGUH50YN	\$271
54"	GSGUH54Y	\$266	54"	GSGUH54YN	\$281
64"	GSGUH64Y	\$292	64"	GSGUH64YN	\$322
76"	GSGUH76Y	\$319	76"	GSGUH76YN	\$347
88"	GSGUH88Y	\$364	88"	GSGUH88YN	\$384
100"	GSGUH100Y	\$393	100"	GSGUH100YN	\$413
120"	GSGUH120Y	\$463	120"	GSGUH120YN	\$483
144"	GSGUH144Y	\$525	144"	GSGUH144YN	\$547

▶ **Specification Information, continued on next page**



For Canadian Pricing
 Multiply U.S. Price by the Canadian price factor.
 ▶ See page 1 for details.

► Specification Information, continued from previous page

Specification Information

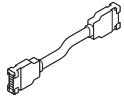

3-Circuit, Separate Neutrals			Non-PVC		
Length	Style Number	U.S. Price	Length	Style Number	U.S. Price
12"	GSGUH12Z	\$220	12"	GSGUH12ZN	\$240
22"	GSGUH22Z	\$220	22"	GSGUH22ZN	\$240
28"	GSGUH28Z	\$220	28"	GSGUH28ZN	\$240
32"	GSGUH32Z	\$220	32"	GSGUH32ZN	\$240
38"	GSGUH38Z	\$220	38"	GSGUH38ZN	\$240
44"	GSGUH44Z	\$252	44"	GSGUH44ZN	\$271
50"	GSGUH50Z	\$252	50"	GSGUH50ZN	\$271
54"	GSGUH54Z	\$266	54"	GSGUH54ZN	\$281
64"	GSGUH64Z	\$292	64"	GSGUH64ZN	\$322
76"	GSGUH76Z	\$319	76"	GSGUH76ZN	\$347
88"	GSGUH88Z	\$364	88"	GSGUH88ZN	\$384
100"	GSGUH100Z	\$393	100"	GSGUH100ZN	\$413
120"	GSGUH120Z	\$463	120"	GSGUH120ZN	\$483
144"	GSGUH144Z	\$525	144"	GSGUH144ZN	\$547

Shared Components

 **For Canadian Pricing**
 Multiply U.S. Price by the
 Canadian price factor.
 ► See page 1 for details.

Wiring and Cabling, continued

Connectors



Tip: Branching harness-to-harness connectors can be used to connect two modular harness together.

Standard Includes		Required to Specify
▶ Need help? Product details, page 178	• Connector: black plastic only	Style number
Specification Information		
Description	Style Number	U.S. Price
4-Circuit, 3+1		
Harness-to-harness	BHHCX	\$ 83
Branching harness-to-harness	GQTUHCX	\$126
4-Circuit, 2+2		
Harness-to-harness	BHHCY	\$ 83
Branching harness-to-harness	GQTUHCY	\$126
3-Circuit, Separate Neutrals		
Harness-to-harness	BHHCZ	\$ 83
Branching harness-to-harness	GQTUHCZ	\$126

Junction Tall Sleeve



Standard Includes		Required to Specify
▶ Need help? Product details, page 183	• Package of ten sleeves: red only	Style number
Specification Information		
Style Number	U.S. Price	
TS7JTSLVE	\$107	



For Canadian Pricing
Multiply U.S. Price by the Canadian price factor.
▶ See page 1 for details.

Lay-In Junction Cable Sleeve

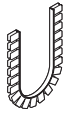

Standard Includes	Required to Specify
<ul style="list-style-type: none"> ▶ Need help? Product details, page 183 • 5' roll of lay-in junction cable sleeve 	<ul style="list-style-type: none"> Style number

Specification Information	
Style Number	U.S. Price
TS7LSLVE	\$150
·	·

Feed-Through Horizontal Cable Sleeves



Standard Includes	Required to Specify
<ul style="list-style-type: none"> ▶ Need help? Product details, page 183 • Package of 25: black plastic 	<ul style="list-style-type: none"> Style number

Specification Information	
Style Number	U.S. Price
TS7FSLVE	\$150
·	·

Grommets for Vertical Junctions (manufactured prior to October 2011) and Horizontal Bars

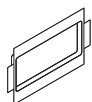

Tip: Grommets can be used on power trays and cable trays.

Standard Includes	Required to Specify
<ul style="list-style-type: none"> ▶ Need help? Product details, page 184 • Package of 25: black plastic 	<ul style="list-style-type: none"> Style number

Specification Information	
Style Number	U.S. Price
TS7HSLVE	\$153
·	·

For Canadian Pricing
 Multiply U.S. Price by the Canadian price factor.
 ▶ See page 1 for details.

Wiring and Cabling, continued

Grommets for Junction



Standard Includes	Required to Specify
<ul style="list-style-type: none"> ▶ Need help? Product details, page 184 • Package of 25: black plastic only 	<ul style="list-style-type: none"> Style number

Specification Information	
• Style Number	• U.S. Price
TS7JSLVE	\$153
·	·

Duplex Cable Grommets

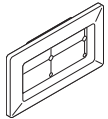

Standard Includes	Required to Specify
<ul style="list-style-type: none"> ▶ Need help? Product details, page 184 • Carton of five cable grommets: plastic 	<ul style="list-style-type: none"> 1 Style number 2 Plastic color number for grommets ▶ See <i>Surface Materials</i>, page 668.

Specification Information	
• Style Number	• U.S. Price
98863	\$48
·	·



For Canadian Pricing
 Multiply U.S. Price by the Canadian price factor.
 ▶ See page 1 for details.

Specifying Universal Systems Worksurfaces and Supports

Worksurfaces		Power and Data Access Door & Tray	546
Straight Worksurfaces	500	Metal Center Drawers	548
Parametric Straight Worksurfaces	504	Connectors	549
Parametric Straight Worksurfaces with Soft Edge Profile	508	Filler Package—Data	550
120° Straight Worksurface	512	Worksurface-Mounted Retractable Power and Data	551
Transition Worksurfaces	514	Panel-Mounted Universal Systems Worksurface Supports	552
Tapered Worksurfaces	516	Off-Module Worksurface-to-Panel Connector	555
Taper-Flat Worksurfaces	517	FrameOne Legs and Supports for Universal Worksurfaces	556
Single-Tapered Worksurfaces	518	Infills for FrameOne Legs for Universal Worksurfaces	557
Corner, Flat-Front Worksurfaces	519	Legs and Columns for Universal Systems Worksurfaces	558
Dual Corner, Flat-Front Worksurfaces	520		
Corner, Straight-Front Worksurfaces	521		
Corner, Curved-Front Worksurfaces	522		
Extended Corner, Straight-Front Worksurfaces	524		
Extended Corner, Curved-Front Worksurfaces	526		
Corner, 120° Worksurfaces	529		
Spanner Worksurfaces	530		
Bullet Peninsula Worksurfaces	532		
Angled Peninsula Worksurfaces	533		
Linking Peninsula Worksurfaces	534		
Jetty Worksurfaces	536		
Bubble Jetty Worksurfaces	538		
Visitor and Linking Worksurfaces	540		
Transaction Worksurfaces	544		

Straight Worksurfaces X 10/24

High-Pressure Laminate or Wood Veneer

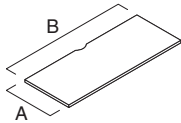

Tip: Supports for freestanding and panel-mounted applications must be specified separately.

Tip: Long work surface spans require additional support.

▶ See understanding section for details, page 210

For composite veneer, wood and laminate group 2 and 3 pricing, please refer to the electronic catalog or SmartTools.

Tip: To specify 3 mm edge profile, no suffix is required. For all other edge profiles, add a suffix to the style number. (For example, US1830 becomes US1830SW for wood with square edge profile.)

Tip: Power and data access door and tray is ordered separately to be used with cutout.

▶ See page 546

▶ See page 212 for work surface size availability matrix.

Exception: 48"W work surface with soft edge used with FrameOne post leg has some limitations.

▶ See page 213 for connections.

Tip: Scallop will be omitted if you select power access door.

Tip: Power access door option includes the power access door and a cutout for the door in the work surface.

Tip: Power access door option is only available on straight work surfaces with 1/2" cord drop.

Standard Includes	Required to Specify
<ul style="list-style-type: none"> ▶ Need help? Product details, page 208 • Worksurface: High-Pressure Laminate price group 1 or wood group 1 veneer • Laminate work surface: <ul style="list-style-type: none"> – Plastic 3 mm edge profile on front edge – Plastic default flat profile on side and back edges • Wood work surface: <ul style="list-style-type: none"> – Wood 3 mm edge profile on front edge – Matching veneer flat profile on side and back edges • Cable scallop on back edge 	<ol style="list-style-type: none"> 1 Style number with appropriate edge profile suffix <ul style="list-style-type: none"> SW Composite veneer or wood with square edge ▶ See edge profiles below. 2 High-Pressure Laminate or wood color number for work surface 3 Plastic color number for front edge on laminate work surface, if selected 4 Options, if selected (see below) ▶ See <i>Surface Materials</i>, page 668.

Options	U.S. Price	Required to Specify
Surface Materials <ul style="list-style-type: none"> • High-Pressure Laminate work surfaces <ul style="list-style-type: none"> • Laminate price group 2 See information at left • Laminate price group 3 See information at left • Open Line laminate +\$102 plus cost of laminate • Composite veneer work surfaces <ul style="list-style-type: none"> • Composite veneer group 1 Prices at right • Composite veneer group 2 See information at left • Wood veneer work surfaces <ul style="list-style-type: none"> • Wood group 2 See information at left • Wood group 3 See information at left • Customiz stain No cost • Full-fill finish on wood group 1 Prices at right 		<ul style="list-style-type: none"> Specify laminate color number. Specify laminate color number. ▶ See <i>Surface Materials Reference Manual</i>. Specify composite veneer color number. Specify composite veneer color number. Specify wood color number. Specify wood color number. Specify with <i>Customiz stain</i>. ▶ See <i>Surface Materials Reference Manual</i>. Specify full-fill finish number.
<ul style="list-style-type: none"> • Door <ul style="list-style-type: none"> • Paint price group 1 No cost • Anodized aluminum +\$ 13 per door 		<ul style="list-style-type: none"> Specify paint color number. Specify with <i>8043 Clear Anodized Aluminum</i>.
<ul style="list-style-type: none"> • Scallop <ul style="list-style-type: none"> • Omit scallop 	No cost	Specify <i>omit scallop</i> .
<ul style="list-style-type: none"> • Cutout for Power and Data Access Door and Tray <ul style="list-style-type: none"> • Cutout 	No cost	Specify with <i>cutout for power and data access door</i> .
<ul style="list-style-type: none"> • Power Access Door <ul style="list-style-type: none"> • Applies to 30"W <ul style="list-style-type: none"> • No power access No cost • Power access door center +\$136 • Applies to 36"W to 48"W <ul style="list-style-type: none"> • No power access No cost • Power access door center +\$136 • Power access door left +\$136 • Power access door right +\$136 • Applies to 54"W to 66"W <ul style="list-style-type: none"> • No power access No cost • Power access door center +\$136 • Power access door left +\$136 • Power access door right +\$136 • Power access door left and right +\$272 		<ul style="list-style-type: none"> Specify with <i>no power access</i>. Specify with <i>power access door center</i>. Specify with <i>no power access</i>. Specify with <i>power access door center</i>. Specify with <i>power access door left</i>. Specify with <i>power access door right</i>. Specify with <i>no power access</i>. Specify with <i>power access door center</i>. Specify with <i>power access door left</i>. Specify with <i>power access door right</i>. Specify with <i>power access door left and right</i>.

▶ Options, continued on next page



For Canadian Pricing

Multiply U.S. Price by the Canadian price factor.

▶ See page 1 for details.





X 10/24 = Last order entry
October 20, 2024

► Options, continued from previous page

Options	U.S. Price	Required to Specify
Power Access Door, continued	Applies to 72"W to 96"W	
• No power access	No cost	Specify with <i>no power access</i> .
• Power access door center	+\$136	Specify with <i>power access door center</i> .
• Power access door left	+\$136	Specify with <i>power access door left</i> .
• Power access door right	+\$136	Specify with <i>power access door right</i> .
• Power access door left and right	+\$272	Specify with <i>power access door left and right</i> .
• Power access door left and center	+\$272	Specify with <i>power access door left and center</i> .
• Power access door right and center	+\$272	Specify with <i>power access door right and center</i> .
• Power access door left, right, and center	+\$408	Specify with <i>power access door left, right, and center</i> .
Related Products	<ul style="list-style-type: none"> • Panel-mounted Universal Systems worksurface supports • Reinforcing channel • Legs and columns for Universal Systems Worksurfaces • Worksurface screens • Worksurface power and communication components 	<ul style="list-style-type: none"> ► Page 552 ► Page 553 ► Page 558 ► Page 571 ► Page 573

Universal Systems Worksurfaces

Specification Information

• Dimensions A B	• Style Number	U.S. Base Prices			• Option (Add \$ to Base Price)	• Dimensions A B	• Style Number	U.S. Base Price High- Pressure Laminate
		High- Pressure Laminate	Composite Veneer	Wood				
								
		• Plastic 3 mm Edge	• Composite Veneer Square Edge	• Wood Square Edge	• Full-Fill Finish on Wood Group 1 Wood			• Plastic 3 mm Edge
		No Suffix	Suffix SW	Suffix SW				

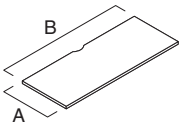

With 1/2" Cord Drop 

18 3/8"	24"	US1824	\$254	N.A.	N.A.	N.A.
18 3/8"	30"	US1830	\$275	\$1000	\$1000	+\$55
18 3/8"	36"	US1836	\$295	\$1020	\$1020	+\$56
18 3/8"	42"	US1842	\$319	\$1164	\$1164	+\$62
18 3/8"	48"	US1848	\$385	\$1230	\$1230	+\$63
18 3/8"	54"	US1854	\$412	\$1257	\$1257	+\$66
18 3/8"	60"	US1860	\$444	\$1439	\$1439	+\$73
18 3/8"	66"	US1866	\$516	N.A.	N.A.	N.A.
18 3/8"	72"	US1872	\$576	N.A.	N.A.	N.A.
18 3/8"	78"	US1878	\$736	N.A.	N.A.	N.A.
18 3/8"	84"	US1884	\$776	N.A.	N.A.	N.A.
18 3/8"	90"	US1890	\$822	N.A.	N.A.	N.A.
18 3/8"	96"	US1896	\$860	N.A.	N.A.	N.A.

With Full Depth 

18 7/8"	24"	WS1824	\$254
18 7/8"	30"	WS1830	\$275
18 7/8"	36"	WS1836	\$295
18 7/8"	42"	WS1842	\$319
18 7/8"	48"	WS1848	\$385
18 7/8"	54"	WS1854	\$412
18 7/8"	60"	WS1860	\$444
18 7/8"	66"	WS1866	\$516
18 7/8"	72"	WS1872	\$576
18 7/8"	78"	WS1878	\$736
18 7/8"	84"	WS1884	\$776
18 7/8"	90"	WS1890	\$822
18 7/8"	96"	WS1896	\$860





► Specification Information, continued on next page

 = Last order entry
October 20, 2024

Straight Worksurfaces High-Pressure Laminate or Wood Veneer, continued

► Specification Information, continued from previous page

Specification Information

• Dimensions A B	• Style Number	U.S. Base Prices			• Option (Add \$ to Base Price)	• Dimensions A B	• Style Number	• Plastic 3 mm Edge
		High-Pressure Laminate	Composite Veneer	Wood				
								
		• Plastic 3 mm Edge	• Composite Veneer Square Edge	• Wood Square Edge	• Full-Fill Finish on Wood Group 1 Wood			
		No Suffix	Suffix SW	Suffix SW				

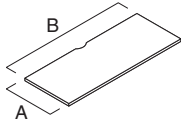

With 1/2" Cord Drop 

23 1/2"	24"	US2424	\$282	\$1007	\$1007	+\$55
23 1/2"	30"	US2430	\$305	\$1030	\$1030	+\$55
23 1/2"	36"	US2436	\$319	\$1044	\$1044	+\$56
23 1/2"	42"	US2442	\$346	\$1191	\$1191	+\$62
23 1/2"	48"	US2448	\$410	\$1255	\$1255	+\$63
23 1/2"	54"	US2454	\$440	\$1285	\$1285	+\$66
23 1/2"	60"	US2460	\$464	\$1459	\$1459	+\$73
23 1/2"	66"	US2466	\$521	\$1516	\$1516	+\$75
23 1/2"	72"	US2472	\$582	\$1577	\$1577	+\$77
23 1/2"	78"	US2478	\$780	N.A.	N.A.	N.A.
23 1/2"	84"	US2484	\$868	N.A.	N.A.	N.A.
23 1/2"	90"	US2490	\$895	N.A.	N.A.	N.A.
23 1/2"	96"	US2496	\$959	N.A.	N.A.	N.A.
29 1/2"	24"	US3024	\$399	\$1124	\$1124	+\$55
29 1/2"	30"	US3030	\$414	\$1139	\$1139	+\$56
29 1/2"	36"	US3036	\$444	\$1169	\$1169	+\$59
29 1/2"	42"	US3042	\$464	\$1309	\$1309	+\$63
29 1/2"	48"	US3048	\$528	\$1373	\$1373	+\$66
29 1/2"	54"	US3054	\$568	\$1413	\$1413	+\$69
29 1/2"	60"	US3060	\$603	\$1598	\$1598	+\$75
29 1/2"	66"	US3066	\$655	\$1650	\$1650	+\$77
29 1/2"	72"	US3072	\$717	\$1712	\$1712	+\$78
35 1/2"	60"	US3660	\$655	N.A.	N.A.	N.A.
35 1/2"	66"	US3666	\$710	N.A.	N.A.	N.A.
35 1/2"	72"	US3672	\$770	N.A.	N.A.	N.A.

Tip: 35 1/2"D worksurfaces can only be used in freestanding applications.

 = Last order entry
October 20, 2024

With Full Depth 

24"	24"	WS2424	\$282
24"	30"	WS2430	\$305
24"	36"	WS2436	\$319
24"	42"	WS2442	\$346
24"	48"	WS2448	\$410
24"	54"	WS2454	\$440
24"	60"	WS2460	\$464
24"	66"	WS2466	\$521
24"	72"	WS2472	\$582
24"	78"	WS2478	\$780
24"	84"	WS2484	\$868
24"	90"	WS2490	\$895
24"	96"	WS2496	\$959
30"	24"	WS3024	\$399
30"	30"	WS3030	\$414
30"	36"	WS3036	\$444
30"	42"	WS3042	\$464
30"	48"	WS3048	\$528
30"	54"	WS3054	\$568
30"	60"	WS3060	\$603
30"	66"	WS3066	\$655
30"	72"	WS3072	\$717

► Options, continued from previous page

	Options	U.S. Price	Required to Specify
Surface Materials, continued	Door		
	• Paint • Anodized aluminum	No cost +\$ 12	Specify paint color number. Specify with 8043 Clear Anodized Aluminum.
Cord Drop	• No cord drop • 1/2" cord drop	No cost No cost	Specify without cord drop. Specify with 1/2" cord drop.
Scallop	• Scallop • Omit scallop	No cost No cost	Specify with scallop. Specify with no scallop.
Cutout for Power and Data Access Door and Tray	Applies to 48"W to 120"W • Cutout	No cost	Specify with cutout for power and data access door.
Power Access Door	Applies to 30"W to 35⁵/₁₆"W		
	• No power access • Power access door center	No cost +\$136	Specify with no power access. Specify with power access door center.
Power Access Door	Applies to 36"W to 51⁵/₁₆"W		
	• No power access	No cost	Specify with no power access.
	• Power access door center	+\$136	Specify with power access door center.
	• Power access door left • Power access door right	+\$136 +\$136	Specify with power access door left. Specify with power access door right.
Power Access Door	Applies to 52"W to 71⁵/₁₆"W		
	• No power access	No cost	Specify with no power access.
	• Power access door center	+\$136	Specify with power access door center.
	• Power access door left • Power access door right	+\$136 +\$136	Specify with power access door left. Specify with power access door right.
	• Power access door left and right	+\$272	Specify with power access door left and right.
Power Access Door	Applies to 72"W to 120"W		
	• No power access	No cost	Specify with no power access.
	• Power access door center	+\$136	Specify with power access door center.
	• Power access door left	+\$136	Specify with power access door left.
	• Power access door right	+\$136	Specify with power access door right.
	• Power access door left and right	+\$272	Specify with power access door left and right.
	• Power access door left and center	+\$272	Specify with power access door left and center.
	• Power access door right and center	+\$272	Specify with power access door right and center.
	• Power access door left, right, and center	+\$408	Specify with power access door left, right, and center.
	Grommet Cutout	• No grommet cutout • 2" grommet cutout • 3" grommet cutout	No cost No cost No cost
Grommet Location	Applies to 18"W to 24¹⁵/₁₆"W • Center	No cost	Specify with center grommet.
	Applies to 25"W to 33¹⁵/₁₆"W		
Grommet Location	• Center	No cost	Specify with center grommet.
	• Left	No cost	Specify with left grommet.
	• Right	No cost	Specify with right grommet.
	• Right and left	No cost	Specify with right and left grommet.
Grommet Location	Applies to 34"W to 120"W		
	• Center	No cost	Specify with center grommet.
	• Left	No cost	Specify with left grommet.
	• Right	No cost	Specify with right grommet.
	• Right and left	No cost	Specify with right and left grommet.
	• Left and center	No cost	Specify with left and center grommet.
	• Right and center	No cost	Specify with right and center grommet.
• Right, left, and center	No cost	Specify with right, left, and center grommet.	

Universal Systems Worksurfaces

Tip: When selecting with cord drop, subtract 1/2" from depth.

Tip: Scallop is available in the center location only. If cutout for power and data access door and tray or power access door is selected, scallop will default to omit scallop.

Tip: Power and data access door and tray is ordered separately to be used with cutout.

► Page 546

► See page 212 for worksurface size availability matrix.

Tip: Cutout for power and data access door and tray is available in the center location only. Worksurface depth must be greater than 24".

Tip: Power access door option is only available on straight worksurfaces with 1/2" cord drop.

Tip: Power access door option includes the power access door and a cutout for the door in the worksurface.

Tip: If cutout for power and data access door and tray or power access door is selected, grommet will default to no grommet.

 **For Canadian Pricing**
Multiply U.S. Price by the Canadian price factor.
► See page 1 for details.

► Options, continued on next page

Parametric Straight Worksurfaces High-Pressure Laminate or Wood Veneer, continued

► Options, continued from previous page

Related Products

- Panel-mounted Universal Systems worksurface supports ► Page 552
- Reinforcing channel ► Page 553
- Legs and columns for Universal Systems Worksurfaces ► Page 558
- Worksurface screens ► Page 571
- Worksurface power and communication components ► Page 573
- 2½" round grommet ► Page 575
- Grommet package ► Page 576

Specification Information

Style Number	Dimensions		U.S. Base Prices						
			Modular Width	18"W	24"W	30"W	36"W	42"W	48"W
	Modular Depth	Parametric Depth	Parametric Width	18"W–23½" W	24"W–29½" W	30"W–35½" W	36"W–41½" W	42"W–47½" W	48"W–53½" W

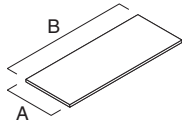

Tip: Dimension A = depth and dimension B = width.

Tip: Side and back edges of worksurface default to a flat profile.

Tip: Worksurfaces greater than 30"D can only be used in freestanding applications.

3 mm Edge Profile–Laminate

USWS	18 7/8"D	18"D–23 7/16"D	\$ 234	\$ 254	\$ 275	\$ 295	\$ 319	\$ 385
	24"D	23 1/2"D–29 7/16"D	\$ 265	\$ 282	\$ 305	\$ 319	\$ 346	\$ 410
	30"D	29 1/2"D–35 7/16"D	\$ 380	\$ 399	\$ 414	\$ 444	\$ 464	\$ 528
	36"D	35 1/2"D–36"D	\$ 455	\$ 473	\$ 494	\$ 514	\$ 538	\$ 603

Knife Edge Profile–Laminate

USWSK	18 7/8"D	18"D–23 7/16"D	\$ 355	\$ 374	\$ 395	\$ 416	\$ 469	\$ 533
	24"D	23 1/2"D–29 7/16"D	\$ 385	\$ 402	\$ 427	\$ 441	\$ 494	\$ 560
	30"D	29 1/2"D–35 7/16"D	\$ 501	\$ 519	\$ 534	\$ 566	\$ 613	\$ 678
	36"D	35 1/2"D–36"D	\$ 576	\$ 596	\$ 613	\$ 633	\$ 686	\$ 750

Square Edge Profile–Composite Veneer

USWSSW	18 7/8"D	18"D–23 7/16"D	\$ 930	\$ 980	\$ 998	\$1021	\$1164	\$1230
	24"D	23 1/2"D–29 7/16"D	\$ 959	\$1010	\$1028	\$1045	\$1189	\$1255
	30"D	29 1/2"D–35 7/16"D	\$1073	\$1124	\$1137	\$1167	\$1311	\$1376
	36"D	35 1/2"D–36"D	\$1297	\$1348	\$1365	\$1401	\$1571	\$1650

Square Edge Profile–Wood

USWSSW	18 7/8"D	18"D–23 7/16"D	\$ 930	\$ 980	\$ 998	\$1021	\$1164	\$1230
	24"D	23 1/2"D–29 7/16"D	\$ 959	\$1010	\$1028	\$1045	\$1189	\$1255
	30"D	29 1/2"D–35 7/16"D	\$1073	\$1124	\$1137	\$1167	\$1311	\$1376
	36"D	35 1/2"D–36"D	\$1297	\$1348	\$1365	\$1401	\$1571	\$1650

► Specifying, continued on next page



For Canadian Pricing
 Multiply U.S. Price by the Canadian price factor.
 ► See page 1 for details.

► Specifying, continued from previous page

: 54"W	: 60"W	: 66"W	: 72"W	: 78"W	: 84"W	: 90"W	: 96"W	: 102"W	: 108"W	: 114"W	: 120"W
: 54"W-	: 60"W-	: 66"W-	: 72"W-	: 78"W-	: 84"W-	: 90"W-	: 96"W-	: 102"W-	: 108"W-	: 114"W-	: 120"W
: 59 ¹⁵ / ₁₆ "W	: 65 ¹⁵ / ₁₆ "W	: 71 ¹⁵ / ₁₆ "W	: 77 ¹⁵ / ₁₆ "W	: 83 ¹⁵ / ₁₆ "W	: 89 ¹⁵ / ₁₆ "W	: 95 ¹⁵ / ₁₆ "W	: 101 ¹⁵ / ₁₆ "W	: 107 ¹⁵ / ₁₆ "W	: 113 ¹⁵ / ₁₆ "W	: 119 ¹⁵ / ₁₆ "W	:

\$ 412	\$ 444	\$ 516	\$ 576	\$ 736	\$ 776	\$ 822	\$ 860	\$ 901	\$ 943	\$ 982	\$1021
\$ 440	\$ 464	\$ 521	\$ 582	\$ 780	\$ 868	\$ 895	\$ 959	\$1000	\$1045	\$1088	\$1129
\$ 568	\$ 603	\$ 655	\$ 717	\$ 925	\$ 966	\$1007	\$1046	\$1085	\$1126	\$1165	\$1208
\$ 632	\$ 655	\$ 710	\$ 770	\$ 966	\$1160	\$1208	\$1255	\$1303	\$1352	\$1398	\$1448
:	:	:	:	:	:	:	:	:	:	:	:

\$ 561	\$ 623	\$ 698	\$ 755	\$ 932	\$ 970	\$1016	\$1055	\$1109	\$1151	\$1189	\$1230
\$ 586	\$ 647	\$ 705	\$ 764	\$ 973	\$1058	\$1092	\$1154	\$1210	\$1252	\$1295	\$1340
\$ 715	\$ 786	\$ 837	\$ 899	\$1121	\$1161	\$1199	\$1240	\$1293	\$1334	\$1376	\$1414
\$ 782	\$ 837	\$ 888	\$ 953	\$1161	\$1353	\$1401	\$1451	\$1512	\$1561	\$1607	\$1655
:	:	:	:	:	:	:	:	:	:	:	:

\$1257	\$1439	\$1513	\$1571	\$1695	\$1908	\$1949	\$1995	\$2066	\$2105	\$2145	\$2217
\$1284	\$1463	\$1519	\$1578	\$1711	\$1940	\$2024	\$2057	\$2148	\$2193	\$2236	\$2309
\$1412	\$1600	\$1652	\$1713	\$1857	\$2096	\$2137	\$2176	\$2248	\$2289	\$2328	\$2400
\$1695	\$1919	\$1984	\$2060	\$2229	\$2515	\$2566	\$2613	\$2697	\$2746	\$2797	\$2881
:	:	:	:	:	:	:	:	:	:	:	:

\$1257	\$1439	\$1513	\$1571	\$1695	\$1908	\$1949	\$1995	\$2066	\$2105	\$2145	\$2217
\$1284	\$1463	\$1519	\$1578	\$1711	\$1940	\$2024	\$2057	\$2148	\$2193	\$2236	\$2309
\$1412	\$1600	\$1652	\$1713	\$1857	\$2096	\$2137	\$2176	\$2248	\$2289	\$2328	\$2400
\$1695	\$1919	\$1984	\$2060	\$2229	\$2515	\$2566	\$2613	\$2697	\$2746	\$2797	\$2881
:	:	:	:	:	:	:	:	:	:	:	:

 **For Canadian Pricing**
Multiply U.S. Price by the
Canadian price factor.
► See page 1 for details.

Parametric Straight Worksurfaces with Soft Edge Profile

High-Pressure Laminate or Wood Veneer

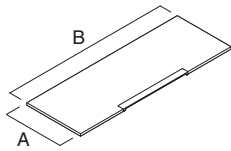

▶ Need help? Product details, page 209

Standard Includes

- Worksurface: High-Pressure Laminate price group 1 or wood group 1 veneer
- Laminate worksurface:
 - Plastic antimicrobial soft edge profile centered on work-surface
 - Plastic 3 mm edge profile on front edge
 - Plastic default flat profile on side and back edges
- Wood worksurface:
 - Plastic antimicrobial soft edge centered on worksurface
 - Wood square edge profile on front edge
 - Matching veneer flat profile on side and back edges
- Depth: 18"D – 36"D
- Width: 18"W – 120"W

Required to Specify

- 1 Style number
 - 2 Worksurface size type (see below under Required Selections)
 - 3 Depth (see below under Required Selections)
 - 4 Width (see below under Required Sections)
 - 5 User edge profile (see below)
 - 6 High-Pressure Laminate or wood color number for worksurface
 - 7 Plastic color number for front edge on laminate worksurface, if selected
 - 8 Options, if selected (see below)
- ▶ See *Surface Materials*, page 668

Tip: Long worksurface spans require additional support. ▶ See understanding section for details, page 211.

	Required Selections	U.S. Price	Required to Specify
Worksurface Size Type	<ul style="list-style-type: none"> • Modular • Parametric 	No cost No cost	Specify with modular. Specify with parametric.

Depth	Required Selections		U.S. Price	Required to Specify
	Modular	Parametric		
• 18 ⁷ / ₈ "D		18"D–23 ⁷ / ₁₆ "D	Prices at right	Specify depth.
• 24"D		23 ¹ / ₂ "D–29 ⁷ / ₁₆ "D	Prices at right	Specify depth.
• 30"D		29 ¹ / ₂ "D–35 ⁷ / ₁₆ "D	Prices at right	Specify depth.
• 36"D		35 ¹ / ₂ "D–36"D	Prices at right	Specify depth.

Width	Required Selections		U.S. Price	Required to Specify
	Modular	Parametric		
• 48"W	48"W	53 ¹⁵ / ₁₆ "W	Prices at right	Specify width.
• 54"W	54"W	59 ¹⁵ / ₁₆ "W	Prices at right	Specify width.
• 60"W	60"W	65 ¹⁵ / ₁₆ "W	Prices at right	Specify width.
• 66"W	66"W	71 ¹⁵ / ₁₆ "W	Prices at right	Specify width.
• 72"W	72"W	77 ¹⁵ / ₁₆ "W	Prices at right	Specify width.
• 78"W	78"W	83 ¹⁵ / ₁₆ "W	Prices at right	Specify width.
• 84"W	84"W	89 ¹⁵ / ₁₆ "W	Prices at right	Specify width.
• 90"W	90"W	95 ¹⁵ / ₁₆ "W	Prices at right	Specify width.
• 96"W	96"W	101 ¹⁵ / ₁₆ "W	Prices at right	Specify width.
• 102"W	102"W	107 ¹⁵ / ₁₆ "W	Prices at right	Specify width.
• 108"W	108"W	113 ¹⁵ / ₁₆ "W	Prices at right	Specify width.
• 114"W	114"W	119 ¹⁵ / ₁₆ "W	Prices at right	Specify width.
• 120"W	120"W		Prices at right	Specify width.

	Options	U.S. Price	Required to Specify
--	---------	------------	---------------------

Surface Materials	High-Pressure Laminate worksurfaces		
	• Laminate price group 2	See information at left	Specify laminate color number.
	• Laminate price group 3	See information at left	Specify laminate color number.
	• Open Line laminate	+\$102 plus cost of laminate	▶ See <i>Surface Materials Reference Manual</i> .

	Composite veneer worksurfaces		
	• Composite veneer group 1	Prices at right	Specify composite veneer color number.
	• Composite veneer group 2	See information at left	Specify composite veneer color number.

	Wood veneer worksurfaces		
	• Wood group 2	See information at left	Specify wood color number.
	• Wood group 3	See information at left	Specify wood color number.
	• Customiz stain	No cost	Specify with Customiz stain.
			▶ See <i>Surface Materials Reference Manual</i> .
	• Full-fill finish on wood group 1	Prices at right	Specify full-fill finish number.

	Wood grain direction		
	• No direction	No cost	Specify with no direction.
	• Long grain	No cost	Specify with long grain direction.
	• Short grain	No cost	Specify with short grain direction.

	Door		
	• Paint	No cost	Specify paint color number.
	• Anodized aluminum	+\$ 12	Specify with 8043 Clear Anodized Aluminum.

▶ Options, continued on next page

For composite veneer, wood and laminate group 2 and 3 pricing, please refer to the electronic catalog or SmartTools.

Tip: Short grain laminate is only available on surfaces 60"W or less.

► Options, continued from previous page

	Options	U.S. Price	Required to Specify
Soft Edge	• Antimicrobial edge	No cost	Specify with antimicrobial edge.
	• No antimicrobial edge	No cost	Specify without antimicrobial edge.
Cord Drop	• No cord drop	No cost	Specify without cord drop.
	• 1/2" cord drop	No cost	Specify with 1/2" cord drop.
Scallop	• Scallop	No cost	Specify with scallop.
	• Omit scallop	No cost	Specify with no scallop.
Cutout for Power and Data Access Door and Tray	Applies to 48"W to 120"W • Cutout	No cost	Specify with cutout for power and data access door.
Power Access Door	Applies to 48"W to 51⁵/₁₆"W • No power access	No cost	Specify with no power access.
	• Power access door center	+\$136	Specify with power access door center.
	• Power access door left	+\$136	Specify with power access door left.
	• Power access door right	+\$136	Specify with power access door right.
	Applies to 52"W to 71⁵/₁₆"W • No power access	No cost	Specify with no power access.
	• Power access door center	+\$136	Specify with power access door center.
	• Power access door left	+\$136	Specify with power access door left.
	• Power access door right	+\$136	Specify with power access door right.
	Applies to 72"W to 120"W • No power access	No cost	Specify with no power access.
	• Power access door center	+\$136	Specify with power access door center.
	• Power access door left	+\$136	Specify with power access door left.
	• Power access door right	+\$136	Specify with power access door right.
	• Power access door left and right	+\$272	Specify with power access door left and right.
	• Power access door left and center	+\$272	Specify with power access door left and center.
	• Power access door right and center	+\$272	Specify with power access door right and center.
	• Power access door left, right, and center	+\$408	Specify with power access door left, right, and center.
Grommet Cutout	• No grommet cutout	No cost	Specify with no grommet cutout.
	• 2" grommet cutout	No cost	Specify with 2" grommet cutout.
	• 3" grommet cutout	No cost	Specify with 3" grommet cutout.
Grommet Location	Applies to 48"W to 120"W • Center	No cost	Specify with center grommet.
	• Left	No cost	Specify with left grommet.
	• Right	No cost	Specify with right grommet.
	• Right and left	No cost	Specify with right and left grommet.
	• Left and center	No cost	Specify with left and center grommet.
	• Right and center	No cost	Specify with right and center grommet.
	• Right, left, and center	No cost	Specify with right, left, and center grommet.
Related Products	• Panel-mounted Universal Systems worksurface supports		► Page 552
	• Reinforcing channel		► Page 553
	• Legs and columns for Universal Systems Worksurfaces		► Page 558
	• Worksurface screens		► Page 571
	• Worksurface power and communication components		► Page 573
	• 2 1/2" round grommet		► Page 575
	• Grommet package		► Page 576

► Specification Information, on next page



For Canadian Pricing

Multiply U.S. Price by the Canadian price factor.

► See page 1 for details.

Parametric Straight Worksurfaces with Soft Edge Profile High-Pressure Laminate or Wood Veneer, continued

► Options, on previous page

Specification Information

Style Number	Dimensions		Modular Width	U.S. Base Prices				
	Modular Depth	Parametric Depth		48"W	54"W	60"W	66"W	72"W
			Parametric Width	48"W-53 ¹⁵ / ₁₆ "W	54"W-59 ¹⁵ / ₁₆ "W	60"W-65 ¹⁵ / ₁₆ "W	66"W-71 ¹⁵ / ₁₆ "W	72"W-77 ¹⁵ / ₁₆ "W

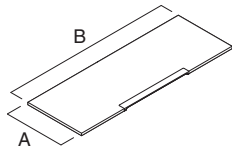

Tip: Dimension A = depth and dimension B = width.

Tip: Side and back edges of worksurface default to a flat profile.

Tip: Worksurfaces greater than 30"D can only be used in freestanding applications.

3 mm Edge Profile–Laminate

uswss	18 ⁷ / ₈ "D	18"D-23 ⁷ / ₁₆ "D	\$ 871	\$ 895	\$ 928	\$ 998	\$1058
	24"D	23 ¹ / ₂ "D-29 ⁷ / ₁₆ "D	\$ 892	\$ 923	\$ 950	\$1008	\$1067
	30"D	29 ¹ / ₂ "D-35 ⁷ / ₁₆ "D	\$1014	\$1051	\$1088	\$1137	\$1202
	36"D	35 ¹ / ₂ "D-36"D	\$1159	\$1187	\$1218	\$1273	\$1334

Square Edge Profile–Composite Veneer

uswssws	18 ⁷ / ₈ "D	18"D-23 ⁷ / ₁₆ "D	\$1713	\$1739	\$1924	\$1999	\$2057
	24"D	23 ¹ / ₂ "D-29 ⁷ / ₁₆ "D	\$1737	\$1768	\$1946	\$2005	\$2064
	30"D	29 ¹ / ₂ "D-35 ⁷ / ₁₆ "D	\$1858	\$1897	\$2085	\$2137	\$2200
	36"D	35 ¹ / ₂ "D-36"D	\$2133	\$2177	\$2403	\$2466	\$2542

Square Edge Profile–Wood

uswssws	18 ⁷ / ₈ "D	18"D-23 ⁷ / ₁₆ "D	\$1713	\$1739	\$1924	\$1999	\$2057
	24"D	23 ¹ / ₂ "D-29 ⁷ / ₁₆ "D	\$1737	\$1768	\$1946	\$2005	\$2064
	30"D	29 ¹ / ₂ "D-35 ⁷ / ₁₆ "D	\$1858	\$1897	\$2085	\$2137	\$2200
	36"D	35 ¹ / ₂ "D-36"D	\$2133	\$2177	\$2403	\$2466	\$2542

► Specifying, continued on next page



For Canadian Pricing
 Multiply U.S. Price by the Canadian price factor.
 ► See page 1 for details.

► Specifying, continued from previous page

: 78"W	: 84"W	: 90"W	: 96"W	: 102"W	: 108"W	: 114"W	: 120"W
: 78"W-	: 84"W-	: 90"W-	: 96"W-	: 102"W-	: 108"W-	: 114"W-	: 120"W
: 83 ¹⁵ / ₁₆ "W	: 89 ¹⁵ / ₁₆ "W	: 95 ¹⁵ / ₁₆ "W	: 101 ¹⁵ / ₁₆ "W	: 107 ¹⁵ / ₁₆ "W	: 113 ¹⁵ / ₁₆ "W	: 119 ¹⁵ / ₁₆ "W	:

\$1220	\$1260	\$1307	\$1345	\$1388	\$1426	\$1466	\$1504
\$1264	\$1348	\$1381	\$1442	\$1486	\$1529	\$1571	\$1616
\$1410	\$1451	\$1490	\$1530	\$1570	\$1611	\$1651	\$1693
\$1451	\$1644	\$1693	\$1737	\$1788	\$1837	\$1886	\$1931
:	:	:	:	:	:	:	:

\$2177	\$2391	\$2435	\$2478	\$2550	\$2588	\$2630	\$2699
\$2197	\$2425	\$2510	\$2540	\$2633	\$2676	\$2722	\$2797
\$2341	\$2580	\$2619	\$2663	\$2733	\$2773	\$2811	\$2884
\$2715	\$3000	\$3049	\$3096	\$3182	\$3229	\$3279	\$3363
:	:	:	:	:	:	:	:

\$2177	\$2391	\$2435	\$2478	\$2550	\$2588	\$2630	\$2699
\$2197	\$2425	\$2510	\$2540	\$2633	\$2676	\$2722	\$2797
\$2341	\$2580	\$2619	\$2663	\$2733	\$2773	\$2811	\$2884
\$2715	\$3000	\$3049	\$3096	\$3182	\$3229	\$3279	\$3363
:	:	:	:	:	:	:	:

 **For Canadian Pricing**
Multiply U.S. Price by the
Canadian price factor.
► See page 1 for details.

120° Straight Worksurfaces

High-Pressure Laminate

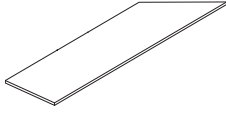

Tip: Supports for freestanding and panel-mounted applications must be specified separately.

For laminate group 2 and 3 pricing, please refer to the electronic catalog or SmartTools.

Tip: Long work surface spans require additional support.
 ▶ See understanding section for details, page 210

Tip: Power and data access door and tray is ordered separately to be used with cutout.

▶ See page 546
 ▶ See page 212 for work surface size availability matrix.

Tip: When facing the user edge, the side the diagonal is on is the handed side.

Tip: Power access door option includes the power access door and a cutout for the door in the work surface.

Standard Includes		Required to Specify
▶ Need help? Product details, page 208	<ul style="list-style-type: none"> • Worksurface: High-Pressure Laminate price group 1 • Laminate worksurface: <ul style="list-style-type: none"> –Plastic 3 mm edge profile on front edge –Plastic default flat profile on side and back edges • Cable scallop on back edge 	<ol style="list-style-type: none"> 1 Style number 2 High-Pressure Laminate color number for worksurface 3 Plastic color number for front edge on laminate worksurface 4 Options, if selected (see below) ▶ See <i>Surface Materials</i> , page 668.

Options	U.S. Price	Required to Specify
Surface Materials <ul style="list-style-type: none"> • High-Pressure Laminate worksurfaces • Laminate price group 2 • Laminate price group 3 • Open Line laminate 	See information at left See information at left +\$102 plus cost of laminate	Specify laminate color number. Specify laminate color number. ▶ See <i>Surface Materials Reference Manual</i> .
Door <ul style="list-style-type: none"> • Paint price group 1 • Anodized aluminum 	No cost +\$ 12 per door	Specify paint color number. Specify with <i>8043 Clear Anodized Aluminum</i> .
Scallop <ul style="list-style-type: none"> • Omit scallop 	No cost	Specify <i>omit scallop</i> .
Power Access Door <p>Applies to 48"W</p> <ul style="list-style-type: none"> • No power access • Power access door center • Power access door left • Power access door right <p>Applies to 60"W</p> <ul style="list-style-type: none"> • No power access • Power access door center • Power access door left • Power access door right • Power access door left and right <p>Applies to 72"W</p> <ul style="list-style-type: none"> • No power access • Power access door center • Power access door left • Power access door right • Power access door left right • Power access door left and center • Power access door right and center • Power access door left, right, and center 	No cost +\$136 +\$136 +\$136 +\$136 +\$272 +\$272 +\$272 +\$272 +\$272 +\$272 +\$408	Specify with <i>no power access</i> . Specify with <i>power access door center</i> . Specify with <i>power access door left</i> . Specify with <i>power access door right</i> . Specify with <i>power access door left and right</i> . Specify with <i>no power access</i> . Specify with <i>power access door center</i> . Specify with <i>power door left</i> . Specify with <i>power door right</i> . Specify with <i>power access door left and and right</i> . Specify with <i>power access door left and center</i> . Specify with <i>power access door right and center</i> . Specify with <i>power access door left, right, and center</i> .
Related Products <ul style="list-style-type: none"> • Panel-mounted Universal Systems worksurface supports • Reinforcing channel • Legs and columns for Universal Systems Worksurfaces • Worksurface screens • Worksurface power and communication components 		▶ Page 552 ▶ Page 553 ▶ Page 558 ▶ Page 571 ▶ Page 573



For Canadian Pricing
 Multiply U.S. Price by the Canadian price factor.
 ▶ See page 1 for details.

Specification Information

**U.S. Base Price
High-Pressure
Laminate**



• Dimensions				• Style Number	• Plastic 3 mm Edge
A	B	C	D		

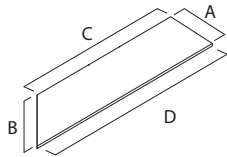

Left-Hand With 1/2" Cord Drop

23 1/2"	27 1/8"	48"	61 1/16"	USE2448LH	\$403
23 1/2"	27 1/8"	60"	73 9/16"	USE2460LH	\$458
23 1/2"	27 1/8"	72"	85 9/16"	USE2472LH	\$574
29 1/2"	34 1/16"	48"	65 1/16"	USE3048LH	\$520
29 1/2"	34 1/16"	60"	77 1/16"	USE3060LH	\$596
29 1/2"	34 1/16"	72"	89 1/16"	USE3072LH	\$709

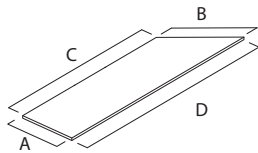

Right-Hand With 1/2" Cord Drop

23 1/2"	27 1/8"	48"	61 1/16"	USE2448RH	\$403
23 1/2"	27 1/8"	60"	73 9/16"	USE2460RH	\$458
23 1/2"	27 1/8"	72"	85 9/16"	USE2472RH	\$574
29 1/2"	34 1/16"	48"	65 1/16"	USE3048RH	\$520
29 1/2"	34 1/16"	60"	77 1/16"	USE3060RH	\$596
29 1/2"	34 1/16"	72"	89 1/16"	USE3072RH	\$709



For Canadian Pricing
 Multiply U.S. Price by the
 Canadian price factor.
 ▶ See page 1 for details.

Transition Worksurfaces

High-Pressure Laminate

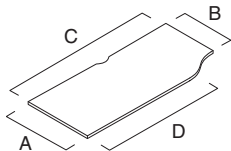

Tip: Illustration above shows a left-hand worksurface.

Tip: Supports for freestanding and panel-mounted applications must be specified separately.

For laminate group 2 and 3 pricing, please refer to the electronic catalog or SmartTools.

Tip: Long worksurface spans require additional support.

▶ See understanding section for details, page 210

Standard Includes		Required to Specify
▶ Need help? Product details, page 208	<ul style="list-style-type: none"> • Worksurface: High-Pressure Laminate price group 1 • Laminate worksurface: <ul style="list-style-type: none"> – Plastic 3 mm edge profile on front edge – Plastic default flat profile on side and back edges • Cable scallop on back edge 	<ol style="list-style-type: none"> 1 Style number 2 High-Pressure Laminate color number for worksurface 3 Plastic color number for front edge on laminate worksurface, if selected 4 Options, if selected (see below) ▶ See <i>Surface Materials</i> , page 668.

Options	U.S. Price	Required to Specify
Surface Materials <ul style="list-style-type: none"> • High-Pressure Laminate worksurfaces • Laminate price group 2 • Laminate price group 3 • Open Line laminate 	See information at left See information at left +\$102 plus cost of laminate	Specify laminate color number. Specify laminate color number. ▶ See <i>Surface Materials Reference Manual</i> .

Scallop <ul style="list-style-type: none"> • Omit scallop 	No cost	Specify <i>omit scallop</i> .
---------------------------------------------------------------------------------	---------	-------------------------------

Related Products <ul style="list-style-type: none"> • Panel-mounted Universal Systems worksurface supports • Legs and columns for Universal Systems Worksurfaces • Worksurface screens • Worksurface power and communication components 	<ul style="list-style-type: none"> ▶ Page 552 ▶ Page 558 ▶ Page 571 ▶ Page 573
------------------------------------------------------------------------------------------------------------------------------------------------------------------------------------------------------------------------------------------------------------------------------------------	--------------------------------------------------------------------------------------------------------------------------





For Canadian Pricing

Multiply U.S. Price by the Canadian price factor.

▶ See page 1 for details.

Specification Information

Dimensions				Style Number	U.S. Base Price High-Pressure Laminate		Plastic 3 mm Edge	Dimensions				Style Number	U.S. Base Price High-Pressure Laminate		Plastic 3 mm Edge
A	B	C	D					A	B	C	D				

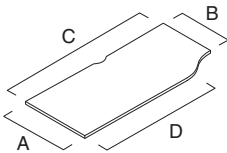

Left-Hand With 1/2" Cord Drop

23 1/2"	18 3/8"	36"	14"	UT2136L	\$528
23 1/2"	18 3/8"	42"	20"	UT2142L	\$562
23 1/2"	18 3/8"	48"	26"	UT2148L	\$653
23 1/2"	18 3/8"	54"	32"	UT2154L	\$700
23 1/2"	18 3/8"	60"	38"	UT2160L	\$743
29 1/2"	23 1/2"	36"	14"	UT3236L	\$626
29 1/2"	23 1/2"	42"	20"	UT3242L	\$656
29 1/2"	23 1/2"	48"	26"	UT3248L	\$766
29 1/2"	23 1/2"	54"	32"	UT3254L	\$823
29 1/2"	23 1/2"	60"	38"	UT3260L	\$874

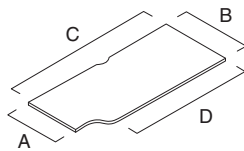

Right-Hand With 1/2" Cord Drop

18 3/8"	23 1/2"	36"	14"	UT1236R	\$528
18 3/8"	23 1/2"	42"	20"	UT1242R	\$562
18 3/8"	23 1/2"	48"	26"	UT1248R	\$653
18 3/8"	23 1/2"	54"	32"	UT1254R	\$700
18 3/8"	23 1/2"	60"	38"	UT1260R	\$743
23 1/2"	29 1/2"	36"	14"	UT2336R	\$626
23 1/2"	29 1/2"	42"	20"	UT2342R	\$656
23 1/2"	29 1/2"	48"	26"	UT2348R	\$766
23 1/2"	29 1/2"	54"	32"	UT2354R	\$823
23 1/2"	29 1/2"	60"	38"	UT2360R	\$874

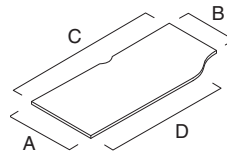

Left-Hand With Full Depth

30"	24"	36"	18"	WT3236	\$626
30"	24"	42"	24"	WT3242	\$656
30"	24"	48"	30"	WT3248	\$766
30"	24"	54"	36"	WT3254	\$823
30"	24"	60"	42"	WT3260	\$874

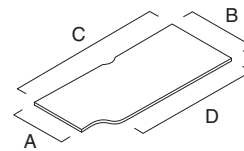

Right-Hand With Full Depth

24"	30"	36"	18"	WT2336	\$626
24"	30"	42"	24"	WT2342	\$656
24"	30"	48"	30"	WT2348	\$766
24"	30"	54"	36"	WT2354	\$823
24"	30"	60"	42"	WT2360	\$874

Tapered Worksurfaces

High-Pressure Laminate

Tip: Supports for freestanding and panel-mounted applications must be specified separately.

Tip: Long worksurface spans require additional support.

▶ See understanding section for details, page 209

Tip: Power and data access door and tray is ordered separately to be used with cutout.

▶ See page 546

For laminate price group 2 and 3 pricing, please refer to the electronic catalog or SmartTools.

Exception: Power and data access door and tray only fits on tapered worksurfaces that are 24" to 30" and 30" to 24" deep.



Standard Includes	Required to Specify
-------------------	---------------------

<ul style="list-style-type: none"> ▶ Need help? Product details, page 208 • Worksurface: High-Pressure Laminate price group 1 • Laminate worksurface: <ul style="list-style-type: none"> –Plastic 3 mm edge profile on front edge –Plastic default flat profile on side and back edges • Cable scallop on back edge 	<ol style="list-style-type: none"> 1 Style number 2 High-Pressure Laminate color number for worksurface 3 Plastic color number for front edge on laminate worksurface 4 Options, if selected (see below) <p>▶ See <i>Surface Materials</i>, page 668.</p>
--------------------------------------------------------------------------------------------------------------------------------------------------------------------------------------------------------------------------------------------------------------------------------------------------------------------------------------------------------------------------------------------------------------------	-----------------------------------------------------------------------------------------------------------------------------------------------------------------------------------------------------------------------------------------------------------------------------------------------------

Options	U.S. Price	Required to Specify
---------	------------	---------------------

Surface Materials High-Pressure Laminate worksurfaces <ul style="list-style-type: none"> • Laminate price group 2 • Laminate price group 3 • Open Line laminate 	See information at left See information at left +\$102 plus cost of laminate	Specify laminate color number. Specify laminate color number. ▶ See <i>Surface Materials Reference Manual</i> .
Scallop <ul style="list-style-type: none"> • Omit scallop 	No cost	Specify <i>omit scallop</i> .
Cutout for Power and Data Access Door and Tray <ul style="list-style-type: none"> • Cutout 	No cost	Specify <i>with cutout for power and data access door</i> .
Related Products <ul style="list-style-type: none"> • Panel-mounted Universal Systems worksurface supports • Legs and columns for Universal Systems Worksurfaces • Worksurface screens • Worksurface power and communication components 		▶ Page 552 ▶ Page 558 ▶ Page 571 ▶ Page 573

Specification Information

			U.S. Base Price High-Pressure Laminate				U.S. Base Price High-Pressure Laminate
							
• Dimensions	• Style	• Plastic		• Dimensions	• Style	• Plastic	
A B C	Number	3 mm		A B C	Number	3 mm	
		Edge				Edge	

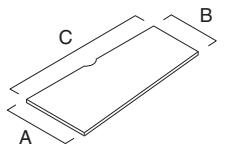

Left-Hand With 1/2" Cord Drop							
23 1/2"	18 3/8"	48"	UTT2148	\$653			
23 1/2"	18 3/8"	60"	UTT2160	\$743			
23 1/2"	18 3/8"	72"	UTT2172	\$832			
29 1/2"	23 1/2"	48"	UTT3248	\$766			
29 1/2"	23 1/2"	60"	UTT3260	\$874			
29 1/2"	23 1/2"	72"	UTT3272	\$979			

Left-Hand With Full Depth							
24"	18 7/8"	48"	WTT2148	\$653			
24"	18 7/8"	60"	WTT2160	\$743			
24"	18 7/8"	72"	WTT2172	\$832			
30"	24"	48"	WTT3248	\$766			
30"	24"	60"	WTT3260	\$874			
30"	24"	72"	WTT3272	\$979			

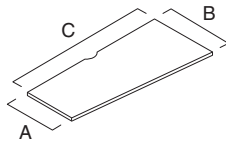

Right-Hand With 1/2" Cord Drop							
18 3/8"	23 1/2"	48"	UTT1248	\$653			
18 3/8"	23 1/2"	60"	UTT1260	\$743			
18 3/8"	23 1/2"	72"	UTT1272	\$832			
23 1/2"	29 1/2"	48"	UTT2348	\$766			
23 1/2"	29 1/2"	60"	UTT2360	\$874			
23 1/2"	29 1/2"	72"	UTT2372	\$979			

Right-Hand With Full Depth							
18 7/8"	24"	48"	WTT1248	\$653			
18 7/8"	24"	60"	WTT1260	\$743			
18 7/8"	24"	72"	WTT1272	\$832			
24"	30"	48"	WTT2348	\$766			
24"	30"	60"	WTT2360	\$874			
24"	30"	72"	WTT2372	\$979			

 **For Canadian Pricing**
 Multiply U.S. Price by the Canadian price factor.
 ▶ See page 1 for details.

Taper-Flat Worksurfaces

High-Pressure Laminate

Tip: Supports for freestanding and panel-mounted applications must be specified separately.

Tip: Long worksurface spans require additional support.
 ▶ See understanding section for details, page 209

For laminate price group 2 and 3 pricing, please refer to the electronic catalog or SmartTools.

Tip: To specify 3 mm edge profile, no suffix is required.

Standard Includes		Required to Specify
▶ Need help? Product details, page 208	<ul style="list-style-type: none"> • Worksurface: High-Pressure Laminate price group 1 • Laminate worksurface: <ul style="list-style-type: none"> –Plastic 3 mm edge profile on front edge –Plastic default flat profile on side and back edges • Cable scallop on back edge 	1 Style number 2 High-Pressure Laminate color number for worksurface 3 Plastic color number for front edge on laminate worksurface 4 Options, if selected (see below) ▶ See <i>Surface Materials</i> , page 668.

Options	U.S. Price	Required to Specify
Surface Materials <ul style="list-style-type: none"> • High-Pressure Laminate worksurfaces <ul style="list-style-type: none"> • Laminate price group 2 • Laminate price group 3 • Open Line laminate 	See information at left See information at left +\$102 plus cost of laminate	Specify laminate color number. Specify laminate color number. ▶ See <i>Surface Materials Reference Manual</i> .
Scallop <ul style="list-style-type: none"> • Omit scallop 	No cost	Specify <i>omit scallop</i> .
Related Products <ul style="list-style-type: none"> • Panel-mounted Universal Systems worksurface supports • Legs and columns for Universal Systems Worksurfaces • Worksurface screens • Worksurface power and communication components 		▶ Page 552 ▶ Page 558 ▶ Page 571 ▶ Page 573

Specification Information

			U.S. Base Price High-Pressure Laminate						U.S. Base Price High-Pressure Laminate			
Dimensions			Style Number	Plastic 3 mm Edge	Dimensions			Style Number	Plastic 3 mm Edge	Dimensions		
A	B	C			A	B	C			A	B	C
Left-Hand With 1/2" Cord Drop												
	23 1/2"	18 3/8"	60"	UTTF2160	\$743							
	23 1/2"	18 3/8"	72"	UTTF2172	\$832							
	29 1/2"	18 3/8"	60"	UTTF3160	\$874							
	29 1/2"	18 3/8"	72"	UTTF3172	\$979							
	29 1/2"	23 1/2"	60"	UTTF3260	\$874							
	29 1/2"	23 1/2"	72"	UTTF3272	\$979							
	:	:	:	:	:							
Left-Hand With Full Depth												
	24"	18 7/8"	60"	WTTF2160	\$743							
	24"	18 7/8"	72"	WTTF2172	\$832							
	30"	18 7/8"	60"	WTTF3160	\$874							
	30"	18 7/8"	72"	WTTF3172	\$979							
	30"	24"	60"	WTTF3260	\$874							
	30"	24"	72"	WTTF3272	\$979							
	:	:	:	:	:							
Right-Hand With 1/2" Cord Drop												
	18 3/8"	23 1/2"	60"	UTTF1260	\$743							
	18 3/8"	23 1/2"	72"	UTTF1272	\$832							
	18 3/8"	29 1/2"	60"	UTTF1360	\$874							
	18 3/8"	29 1/2"	72"	UTTF1372	\$979							
	23 1/2"	29 1/2"	60"	UTTF2360	\$874							
	23 1/2"	29 1/2"	72"	UTTF2372	\$979							
	:	:	:	:	:							
Right-Hand With Full Depth												
	18 7/8"	24"	60"	WTTF1260	\$743							
	18 7/8"	24"	72"	WTTF1272	\$832							
	18 7/8"	30"	60"	WTTF1360	\$874							
	18 7/8"	30"	72"	WTTF1372	\$979							
	24"	30"	60"	WTTF2360	\$874							
	24"	30"	72"	WTTF2372	\$979							
	:	:	:	:	:							

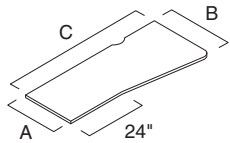
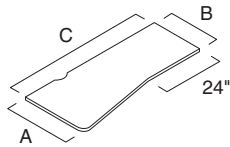

For Canadian Pricing
 Multiply U.S. Price by the Canadian price factor.
 ▶ See page 1 for details.

Single-Tapered Worksurfaces

High-Pressure Laminate

Tip: Supports for freestanding and panel-mounted applications must be specified separately.

Tip: Long worksurface spans require additional support.

▶ See understanding section for details, page 209

For laminate price group 2 and 3 pricing, please refer to the electronic catalog or SmartTools.

Tip: To specify 3 mm edge profile, no suffix is required.

Standard Includes	Required to Specify
-------------------	---------------------

<ul style="list-style-type: none"> ▶ Need help? Product details, page 208 • Worksurface: High-Pressure Laminate price group 1 • Laminate worksurface: <ul style="list-style-type: none"> –Plastic 3 mm edge profile on front edge –Plastic default flat profile on side and back edges • Cable scallop on back edge 	<ol style="list-style-type: none"> 1 Style number 2 High-Pressure Laminate color number for worksurface 3 Plastic color number for front edge on laminate worksurface 4 Options, if selected (see below) <p>▶ See <i>Surface Materials</i>, page 668.</p>
--------------------------------------------------------------------------------------------------------------------------------------------------------------------------------------------------------------------------------------------------------------------------------------------------------------------------------------------------------------------------------------------------------------------	-----------------------------------------------------------------------------------------------------------------------------------------------------------------------------------------------------------------------------------------------------------------------------------------------------

Options	U.S. Price	Required to Specify
---------	------------	---------------------

Surface Materials <ul style="list-style-type: none"> • High-Pressure Laminate worksurfaces • Laminate price group 2 • Laminate price group 3 • Open Line laminate 	See information at left See information at left +\$102 plus cost of laminate	Specify laminate color number. Specify laminate color number. ▶ See <i>Surface Materials Reference Manual</i> .
Scallop <ul style="list-style-type: none"> • Omit scallop 	No cost	Specify <i>omit scallop</i> .
Related Products <ul style="list-style-type: none"> • Panel-mounted Universal Systems worksurface supports • Legs and columns for Universal Systems Worksurfaces • Worksurface screens • Worksurface power and communication components 		▶ Page 552 ▶ Page 558 ▶ Page 571 ▶ Page 573

Specification Information

			U.S. Base Price High-Pressure Laminate				U.S. Base Price High-Pressure Laminate	
• Dimensions			• Style			• Plastic 3 mm Edge		
A	B	C	Number	Number	Number	Number	Number	Number

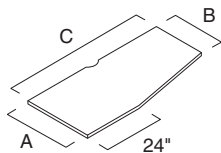

Left-Hand With 1/2" Cord Drop

23 1/2"	18 3/8"	60"	UST2160	\$743
23 1/2"	18 3/8"	72"	UST2172	\$832
29 1/2"	23 1/2"	60"	UST3260	\$874
29 1/2"	23 1/2"	72"	UST3272	\$979
⋮	⋮	⋮	⋮	⋮

Left-Hand With Full Depth

24"	18 7/8"	60"	WST2160	\$743
24"	18 7/8"	72"	WST2172	\$832
30"	24"	60"	WST3260	\$874
30"	24"	72"	WST3272	\$979
⋮	⋮	⋮	⋮	⋮

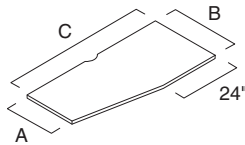

Right-Hand With 1/2" Cord Drop

18 3/8"	23 1/2"	60"	UST1260	\$743
18 3/8"	23 1/2"	72"	UST1272	\$832
23 1/2"	29 1/2"	60"	UST2360	\$874
23 1/2"	29 1/2"	72"	UST2372	\$979
⋮	⋮	⋮	⋮	⋮

Right-Hand With Full Depth

18 7/8"	24"	60"	WST1260	\$743
18 7/8"	24"	72"	WST1272	\$832
24"	30"	60"	WST2360	\$874
24"	30"	72"	WST2372	\$979
⋮	⋮	⋮	⋮	⋮

For Canadian Pricing
 Multiply U.S. Price by the Canadian price factor.
 ▶ See page 1 for details.

Corner, Flat-Front Worksurfaces

High-Pressure Laminate

Corner, Flat-Front Worksurfaces

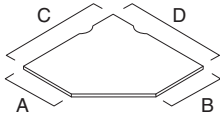

Tip: Supports must be specified separately, including side support brackets for rear corner support in panel-mounted applications.

For laminate price group 2 and 3 pricing, please refer to the electronic catalog or SmartTools.

Tip: To specify 3 mm edge profile, no suffix is required.

Standard Includes	Required to Specify
<ul style="list-style-type: none"> ▶ Need help? Product details, page 208 • Worksurface: High-Pressure Laminate price group 1 <ul style="list-style-type: none"> –Plastic 3 mm edge profile on front edge –Plastic default flat profile on side and back edges • Cable scallops on back edges 	<ol style="list-style-type: none"> 1 Style number 2 High-Pressure Laminate color number for worksurface 3 Plastic color number for front edge on laminate worksurface 4 Options, if selected (see below) <ul style="list-style-type: none"> ▶ See <i>Surface Materials</i>, page 668.

Options	U.S. Price	Required to Specify
Surface Materials <ul style="list-style-type: none"> • High-Pressure Laminate worksurfaces <ul style="list-style-type: none"> • Laminate price group 2 • Laminate price group 3 • Open Line laminate 	See information at left See information at left +\$102 plus cost of laminate	Specify laminate color number. Specify laminate color number. ▶ See <i>Surface Materials Reference Manual</i> .
Scallops <ul style="list-style-type: none"> • Omit scallops 	No cost	Specify <i>omit scallops</i> .
Related Products <ul style="list-style-type: none"> • Panel-mounted Universal Systems worksurface supports • Legs and columns for Universal Systems Worksurfaces • Worksurface screens • Worksurface power and communication components 		▶ Page 552 ▶ Page 558 ▶ Page 571 ▶ Page 573

Universal Systems Worksurfaces

Specification Information

				U.S. Base Price High-Pressure Laminate							U.S. Base Price High-Pressure Laminate		
• Dimensions				• Style Number			• Dimensions				• Style Number		
A	B	C	D				A	B	C	D			
With 1/2" Cord Drop							With Full Depth						
23 1/2"	23 1/2"	35 1/2"	35 1/2"	UCF223636		\$560	24"	24"	36"	36"	WCF223636		\$560
23 1/2"	23 1/2"	41 1/2"	41 1/2"	UCF224242		\$610	24"	24"	42"	42"	WCF224242		\$610
23 1/2"	23 1/2"	47 1/2"	47 1/2"	UCF224848		\$691	24"	24"	48"	48"	WCF224848		\$691
29 1/2"	29 1/2"	41 1/2"	41 1/2"	UCF334242		\$671	30"	30"	42"	42"	WCF334242		\$671
29 1/2"	29 1/2"	47 1/2"	47 1/2"	UCF334848		\$760	30"	30"	48"	48"	WCF334848		\$760

For Canadian Pricing
 Multiply U.S. Price by the Canadian price factor.
 ▶ See page 1 for details.

Dual Corner, Flat-Front Worksurfaces

High-Pressure Laminate

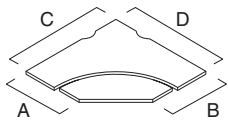

Tip: Supports must be specified separately, including side support brackets for rear corner support in panel-mounted applications.

For laminate price group 2 and 3 pricing, please refer to the electronic catalog or SmartTools.

Tip: Keyboard surface adjusts 6" higher or 5" lower than worksurface height.

Tip: Dual corner, flat-front worksurfaces must be panel hung.

Tip: 23 1/2"D dual corner, flat-front worksurfaces must be supported with a center support on each side.

Tip: 29 1/2"D dual corner, flat-front worksurfaces can be supported with a cantilever or center support.

Tip: To specify 3 mm edge profile, no suffix is required.

Standard Includes

▶ Need help? Product details, page 208

- Worksurface: High-Pressure Laminate price group 1
- Laminate worksurface:
 - Plastic 3 mm edge profile on front edge of keyboard surface
 - Plastic default flat profile on all other edges
- Cable scallops on back edges
- Keyboard mechanism

Required to Specify

- 1 Style number
 - 2 High-Pressure Laminate color number for worksurface
 - 3 Plastic color number for edges on laminate worksurface
 - 4 Options, if selected (see below)
- ▶ See *Surface Materials*, page 668.

Options

Surface Materials	Options	U.S. Price	Required to Specify
	High-Pressure Laminate worksurfaces		
	• Laminate price group 2	See information at left	Specify laminate color number.
	• Laminate price group 3	See information at left	Specify laminate color number.
	• Open Line laminate	+\$102 plus cost of laminate	▶ See <i>Surface Materials Reference Manual</i> .

Scallops	Options	U.S. Price	Required to Specify
	• Omit scallops	No cost	Specify <i>omit scallops</i> .

Related Products	Options	U.S. Price	Required to Specify
	• Panel-mounted Universal Systems worksurface supports		▶ Page 552
	• Legs and columns for Universal Systems Worksurfaces		▶ Page 558
	• Worksurface screens		▶ Page 571
	• Worksurface power and communication components		▶ Page 573

Specification Information

Dimensions				Style Number	U.S. Base Price High-Pressure Laminate	Plastic 3 mm Edge
A	B	C	D			

Dimensions				Style Number	U.S. Base Price High-Pressure Laminate	Plastic 3 mm Edge
A	B	C	D			

With 1/2" Cord Drop

23 1/2"	23 1/2"	41 1/2"	41 1/2"	UDC224242	\$1493
23 1/2"	23 1/2"	47 1/2"	47 1/2"	UDC224848	\$1575
29 1/2"	29 1/2"	47 1/2"	47 1/2"	UDC334848	\$1637

With Full Depth

24"	24"	42"	42"	WDC224242	\$1493
24"	24"	48"	48"	WDC224848	\$1575
30"	30"	48"	48"	WDC334848	\$1637



For Canadian Pricing

Multiply U.S. Price by the Canadian price factor.

▶ See page 1 for details.

Corner, Straight-Front Worksurfaces

High-Pressure Laminate

Corner, Straight-Front Worksurfaces

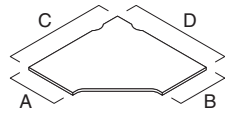

Tip: Supports must be specified separately, including side support brackets for rear corner support in panel-mounted applications.

For laminate price group 2 and 3 pricing, please refer to the electronic catalog or SmartTools.

Standard Includes		Required to Specify
<ul style="list-style-type: none"> ▶ Need help? Product details, page 208 	<ul style="list-style-type: none"> • Worksurface: High-Pressure Laminate price group 1 <ul style="list-style-type: none"> – Plastic 3 mm edge profile on front edge – Plastic default flat profile on side and back edges • Cable scallops on back edges 	<ol style="list-style-type: none"> 1 Style number 2 High-Pressure Laminate color number for worksurface 3 Plastic color number for front edge on laminate worksurface 4 Options, if selected (see below) <p>▶ See <i>Surface Materials</i>, page 668.</p>

Options	U.S. Price	Required to Specify
Surface Materials <ul style="list-style-type: none"> • High-Pressure Laminate worksurfaces <ul style="list-style-type: none"> • Laminate price group 2 • Laminate price group 3 • Open Line laminate 	See information at left See information at left +\$102 plus cost of laminate	Specify laminate color number. Specify laminate color number. ▶ See <i>Surface Materials Reference Manual</i> .
Scallops <ul style="list-style-type: none"> • Omit scallops 	No cost	Specify <i>omit scallops</i> .
Related Products <ul style="list-style-type: none"> • Panel-mounted Universal Systems worksurface supports • Legs and columns for Universal Systems Worksurfaces • Worksurface screens • Worksurface power and communication components 		▶ Page 552 ▶ Page 558 ▶ Page 571 ▶ Page 573

Specification Information

Dimensions				Style Number	U.S. Base Prices High-Pressure Laminate
A	B	C	D		Plastic 3 mm Edge
18"	18"	42"	42"	UC114242	\$ 583
18 ³ / ₈ "	23 ¹ / ₂ "	41 ¹ / ₂ "	41 ¹ / ₂ "	UC124242	\$ 644
23 ¹ / ₂ "	18 ³ / ₈ "	41 ¹ / ₂ "	41 ¹ / ₂ "	UC214242	\$ 644
23 ¹ / ₂ "	23 ¹ / ₂ "	35 ¹ / ₂ "	35 ¹ / ₂ "	UC223636	\$ 560
23 ¹ / ₂ "	23 ¹ / ₂ "	41 ¹ / ₂ "	41 ¹ / ₂ "	UC224242	\$ 610
23 ¹ / ₂ "	23 ¹ / ₂ "	47 ¹ / ₂ "	47 ¹ / ₂ "	UC224848	\$ 691
23 ¹ / ₂ "	23 ¹ / ₂ "	59 ¹ / ₂ "	59 ¹ / ₂ "	UC226060	\$1282
29 ¹ / ₂ "	29 ¹ / ₂ "	41 ¹ / ₂ "	41 ¹ / ₂ "	UC334242	\$ 671
29 ¹ / ₂ "	29 ¹ / ₂ "	47 ¹ / ₂ "	47 ¹ / ₂ "	UC334848	\$ 760

With 1/2" Cord Drop

18"	18"	42"	42"	UC114242	\$ 583
18 ³ / ₈ "	23 ¹ / ₂ "	41 ¹ / ₂ "	41 ¹ / ₂ "	UC124242	\$ 644
23 ¹ / ₂ "	18 ³ / ₈ "	41 ¹ / ₂ "	41 ¹ / ₂ "	UC214242	\$ 644
23 ¹ / ₂ "	23 ¹ / ₂ "	35 ¹ / ₂ "	35 ¹ / ₂ "	UC223636	\$ 560
23 ¹ / ₂ "	23 ¹ / ₂ "	41 ¹ / ₂ "	41 ¹ / ₂ "	UC224242	\$ 610
23 ¹ / ₂ "	23 ¹ / ₂ "	47 ¹ / ₂ "	47 ¹ / ₂ "	UC224848	\$ 691
23 ¹ / ₂ "	23 ¹ / ₂ "	59 ¹ / ₂ "	59 ¹ / ₂ "	UC226060	\$1282
29 ¹ / ₂ "	29 ¹ / ₂ "	41 ¹ / ₂ "	41 ¹ / ₂ "	UC334242	\$ 671
29 ¹ / ₂ "	29 ¹ / ₂ "	47 ¹ / ₂ "	47 ¹ / ₂ "	UC334848	\$ 760

 **For Canadian Pricing**
 Multiply U.S. Price by the Canadian price factor.
 ▶ See page 1 for details.

Corner, Curved-Front Worksurfaces

High-Pressure Laminate or Wood Veneer

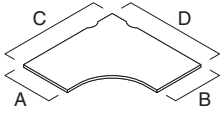

Tip: Supports must be specified separately, including side support brackets for rear corner support in panel-mounted applications.

For composite veneer, wood and laminate group 2 and 3 pricing, please refer to the electronic catalog or SmartTools.

Standard Includes	Required to Specify
<ul style="list-style-type: none"> ▶ Need help? Product details, page 208 • Worksurface: High-Pressure Laminate price group 1 or wood group 1 veneer • Laminate worksurface: <ul style="list-style-type: none"> – Plastic 3 mm edge profile on front edge – Plastic default flat profile on side and back edges • Wood worksurface: <ul style="list-style-type: none"> – Wood 3 mm edge profile on front edge – Matching veneer flat profile on side and back edges • Cable scallops on back edges 	<ol style="list-style-type: none"> 1 Style number with appropriate edge profile suffix <ul style="list-style-type: none"> SW Composite veneer or wood with square edge ▶ See edge profiles below. 2 High-Pressure Laminate or wood color number for worksurface 3 Plastic color number for front edge on laminate worksurface, if selected 4 Options, if selected (see below) ▶ See <i>Surface Materials</i>, page 668.

Options	U.S. Price	Required to Specify
<p>Surface Materials</p> <ul style="list-style-type: none"> • High-Pressure Laminate worksurfaces • Laminate price group 2 • Laminate price group 3 • Open Line laminate 	<ul style="list-style-type: none"> See information at left See information at left +\$102 plus cost of laminate 	<ul style="list-style-type: none"> Specify laminate color number. Specify laminate color number. ▶ See <i>Surface Materials Reference Manual</i>.
<ul style="list-style-type: none"> • Composite veneer worksurfaces • Composite veneer group 1 • Composite veneer group 2 	<ul style="list-style-type: none"> Prices at right See information at left 	<ul style="list-style-type: none"> Specify composite veneer color number. Specify composite veneer color number.
<ul style="list-style-type: none"> • Wood veneer worksurfaces • Wood group 2 • Wood group 3 • Customiz stain 	<ul style="list-style-type: none"> See information at left See information at left No cost 	<ul style="list-style-type: none"> Specify wood color number. Specify wood color number. Specify with <i>Customiz stain</i>. ▶ See <i>Surface Materials Reference Manual</i>.
<ul style="list-style-type: none"> • Full-fill finish on wood group 1 	<ul style="list-style-type: none"> Prices at right 	<ul style="list-style-type: none"> Specify full-fill finish number.
<p>Scallops</p> <ul style="list-style-type: none"> • Omit scallops 	<ul style="list-style-type: none"> No cost 	<ul style="list-style-type: none"> Specify <i>omit scallops</i>.
<p>Related Products</p> <ul style="list-style-type: none"> • Panel-mounted Universal Systems worksurface supports • Legs and columns for Universal Systems Worksurfaces • Worksurface screens • Worksurface power and communication components 		<ul style="list-style-type: none"> ▶ Page 552 ▶ Page 558 ▶ Page 571 ▶ Page 573



For Canadian Pricing
 Multiply U.S. Price by the Canadian price factor.
 ▶ See page 1 for details.

Specification Information

• Dimensions				• Style Number	U.S. Base Prices			• Option (Add \$ to Base Price) Full-Fill Finish on Wood Group 1	• Dimensions				• Style Number	U.S. Base Price		
A	B	C	D		High-Pressure Laminate	Composite Veneer	Wood		A	B	C	D		High-Pressure Laminate		

With 1/2" Cord Drop

• Plastic 3 mm Edge	• Composite Veneer Square Edge	• Wood Square Edge	• Option
No Suffix	Suffix SW	Suffix SW	
18 ³ / ₈ " 18 ³ / ₈ " 35 ¹ / ₂ " 35 ¹ / ₂ "	UCC113636	\$ 650	N.A.
18 ³ / ₈ " 18 ³ / ₈ " 41 ¹ / ₂ " 41 ¹ / ₂ "	UCC114242	\$ 691	\$1645
18 ³ / ₈ " 18 ³ / ₈ " 47 ¹ / ₂ " 47 ¹ / ₂ "	UCC114848	\$ 772	N.A.
18 ³ / ₈ " 23 ¹ / ₂ " 41 ¹ / ₂ " 41 ¹ / ₂ "	UCC124242	\$ 743	\$1697
23 ¹ / ₂ " 18 ³ / ₈ " 41 ¹ / ₂ " 41 ¹ / ₂ "	UCC214242	\$ 743	\$1697
23 ¹ / ₂ " 23 ¹ / ₂ " 35 ¹ / ₂ " 35 ¹ / ₂ "	UCC223636	\$ 657	\$1611
23 ¹ / ₂ " 23 ¹ / ₂ " 41 ¹ / ₂ " 41 ¹ / ₂ "	UCC224242	\$ 717	\$1671
23 ¹ / ₂ " 23 ¹ / ₂ " 47 ¹ / ₂ " 47 ¹ / ₂ "	UCC224848	\$ 797	\$1751
23 ¹ / ₂ " 23 ¹ / ₂ " 59 ¹ / ₂ " 59 ¹ / ₂ "	UCC226060	\$1282	N.A.
29 ¹ / ₂ " 29 ¹ / ₂ " 41 ¹ / ₂ " 41 ¹ / ₂ "	UCC334242	\$ 776	\$1730
29 ¹ / ₂ " 29 ¹ / ₂ " 47 ¹ / ₂ " 47 ¹ / ₂ "	UCC334848	\$ 868	\$1822

With Full Depth

18 ⁷ / ₈ " 18 ⁷ / ₈ " 36" 36"	WCC113636	\$650
18 ⁷ / ₈ " 18 ⁷ / ₈ " 42" 42"	WCC114242	\$691
18 ⁷ / ₈ " 18 ⁷ / ₈ " 48" 48"	WCC114848	\$772
18 ⁷ / ₈ " 24" 42" 42"	WCC124242	\$743
24" 18 ⁷ / ₈ " 42" 42"	WCC214242	\$743
24" 24" 36" 36"	WCC223636	\$657
24" 24" 42" 42"	WCC224242	\$717
24" 24" 48" 48"	WCC224848	\$797
30" 30" 42" 42"	WCC334242	\$776
30" 30" 48" 48"	WCC334848	\$868

Tip: To specify 3 mm edge profile, no suffix is required. For all other edge profiles, add a suffix to the style number. (For example, **UCC114242** becomes **UCC114242SW** for wood with square edge profile.)



For Canadian Pricing
Multiply U.S. Price by the Canadian price factor.
▶ See page 1 for details.

Extended Corner, Straight-Front Worksurfaces

High-Pressure Laminate

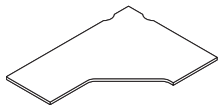

Tip: Illustration above shows a left-hand worksurface.

Tip: Supports must be specified separately, including side support brackets for rear corner support in panel-mounted applications.

For laminate price group 2 and 3 pricing, please refer to the electronic catalog or SmartTools.

Tip: Long worksurface spans require additional support.

▶ See understanding section for details, page 210

Standard Includes		Required to Specify
▶ Need help? Product details, page 208	<ul style="list-style-type: none"> • Worksurface: High-Pressure Laminate price group 1 • Laminate worksurface: <ul style="list-style-type: none"> – Plastic 3 mm edge profile on front edge – Plastic default flat profile on side and back edges • Cable scallops on back edges 	<ol style="list-style-type: none"> 1 Style number 2 High-Pressure Laminate number for worksurface 3 Plastic color number for front edge on laminate worksurface 4 Options, if selected (see below) <p>▶ See <i>Surface Materials</i>, page 668.</p>

	Options	U.S. Price	Required to Specify
Surface Materials	High-Pressure Laminate worksurfaces <ul style="list-style-type: none"> • Laminate price group 2 • Laminate price group 3 • Open Line laminate 	See information at left See information at left +\$102 plus cost of laminate	Specify laminate color number. Specify laminate color number. ▶ See <i>Surface Materials Reference Manual</i> .
Scallops	<ul style="list-style-type: none"> • Omit scallops 	No cost	Specify <i>omit scallops</i> .
Related Products	<ul style="list-style-type: none"> • Panel-mounted Universal Systems worksurface supports • Reinforcing channel • Legs and columns for Universal Systems Worksurfaces • Worksurface screens • Worksurface power and communication components 		▶ Page 552 ▶ Page 553 ▶ Page 558 ▶ Page 571 ▶ Page 573



For Canadian Pricing

Multiply U.S. Price by the Canadian price factor.

▶ See page 1 for details.

Specification Information

**U.S. Base Prices
High-Pressure Laminate**



• Dimensions				• Style Number	• Plastic 3 mm Edge
A	B	C	D		

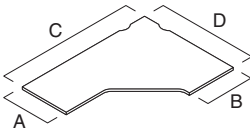

Left-Hand With 1/2" Cord Drop

23 1/2"	23 1/2"	59 1/2"	41 1/2"	UE2202L	\$1058
23 1/2"	23 1/2"	65 1/2"	41 1/2"	UE2262L	\$1158
23 1/2"	23 1/2"	71 1/2"	41 1/2"	UE2222L	\$1254
23 1/2"	23 1/2"	59 1/2"	47 1/2"	UE2208L	\$1088
23 1/2"	23 1/2"	65 1/2"	47 1/2"	UE2268L	\$1180
23 1/2"	23 1/2"	71 1/2"	47 1/2"	UE2228L	\$1274
23 1/2"	29 1/2"	59 1/2"	47 1/2"	UE2308L	\$1187
23 1/2"	29 1/2"	65 1/2"	47 1/2"	UE2368L	\$1282
23 1/2"	29 1/2"	71 1/2"	47 1/2"	UE2328L	\$1384
29 1/2"	23 1/2"	59 1/2"	47 1/2"	UE3208L	\$1187
29 1/2"	23 1/2"	65 1/2"	47 1/2"	UE3268L	\$1282
29 1/2"	23 1/2"	71 1/2"	47 1/2"	UE3228L	\$1384
29 1/2"	29 1/2"	59 1/2"	47 1/2"	UE3308L	\$1242
29 1/2"	29 1/2"	65 1/2"	47 1/2"	UE3368L	\$1343
29 1/2"	29 1/2"	71 1/2"	47 1/2"	UE3328L	\$1437

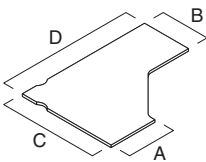

Right-Hand With 1/2" Cord Drop

23 1/2"	23 1/2"	41 1/2"	59 1/2"	UE2220R	\$1058
23 1/2"	23 1/2"	41 1/2"	65 1/2"	UE2226R	\$1158
23 1/2"	23 1/2"	41 1/2"	71 1/2"	UE2222R	\$1254
23 1/2"	23 1/2"	47 1/2"	59 1/2"	UE2280R	\$1088
23 1/2"	23 1/2"	47 1/2"	65 1/2"	UE2286R	\$1180
23 1/2"	23 1/2"	47 1/2"	71 1/2"	UE2282R	\$1274
23 1/2"	29 1/2"	47 1/2"	59 1/2"	UE2380R	\$1187
23 1/2"	29 1/2"	47 1/2"	65 1/2"	UE2386R	\$1282
23 1/2"	29 1/2"	47 1/2"	71 1/2"	UE2382R	\$1384
29 1/2"	23 1/2"	47 1/2"	59 1/2"	UE3280R	\$1187
29 1/2"	23 1/2"	47 1/2"	65 1/2"	UE3286R	\$1282
29 1/2"	23 1/2"	47 1/2"	71 1/2"	UE3282R	\$1384
29 1/2"	29 1/2"	47 1/2"	59 1/2"	UE3380R	\$1242
29 1/2"	29 1/2"	47 1/2"	65 1/2"	UE3386R	\$1343
29 1/2"	29 1/2"	47 1/2"	71 1/2"	UE3382R	\$1437

 **For Canadian Pricing**
 Multiply U.S. Price by the Canadian price factor.
 ▶ See page 1 for details.

Universal Systems Worksurfaces

Extended Corner, Curved-Front Worksurfaces

High-Pressure Laminate or Wood Veneer

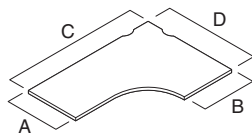

Left-Hand

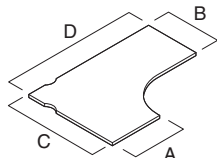

Right-Hand

Tip: Supports must be specified separately, including side support brackets for rear corner support in panel-mounted applications.

For composite veneer, wood and laminate group 2 and 3 pricing, please refer to the electronic catalog or SmartTools.

Tip: Long worksurface spans require additional support.

▶ See understanding section for details, page 210

Standard Includes	Required to Specify
<ul style="list-style-type: none"> ▶ Need help? Product details, page 208 • Worksurface: High-Pressure Laminate price group 1 or wood group 1 veneer • Laminate worksurface: <ul style="list-style-type: none"> – Plastic 3 mm edge profile on front edge – Plastic default flat profile on side and back edges • Wood worksurface: <ul style="list-style-type: none"> – Wood 3 mm edge profile on front edge – Matching veneer flat profile on side and back edges • Cable scallops on back edges 	<ol style="list-style-type: none"> 1 Style number with appropriate edge profile suffix <ul style="list-style-type: none"> SW Composite veneer or wood with square edge ▶ See edge profiles below. 2 High-Pressure Laminate or wood color number for worksurface 3 Plastic color number for front edge on laminate worksurface, if selected 4 Options, if selected (see below) ▶ See <i>Surface Materials</i>, page 668.

Options	U.S. Price	Required to Specify
Surface Materials <ul style="list-style-type: none"> • High-Pressure Laminate worksurfaces • Laminate price group 2 • Laminate price group 3 • Open Line laminate 	<ul style="list-style-type: none"> See information at left See information at left +\$102 plus cost of laminate 	<ul style="list-style-type: none"> Specify laminate color number. Specify laminate color number. ▶ See <i>Surface Materials Reference Manual</i>.
<ul style="list-style-type: none"> • Composite veneer worksurfaces • Composite veneer group 1 • Composite veneer group 2 	<ul style="list-style-type: none"> Prices at right See information at left 	<ul style="list-style-type: none"> Specify composite veneer color number. Specify composite veneer color number.
<ul style="list-style-type: none"> • Wood veneer worksurfaces • Wood group 2 • Wood group 3 • Customiz stain 	<ul style="list-style-type: none"> See information at left See information at left No cost 	<ul style="list-style-type: none"> Specify wood color number. Specify wood color number. Specify with <i>Customiz stain</i>. ▶ See <i>Surface Materials Reference Manual</i>. Specify full-fill finish number.
<ul style="list-style-type: none"> • Full-fill finish on wood group 1 	<ul style="list-style-type: none"> Prices at right 	<ul style="list-style-type: none"> Specify full-fill finish number.
Scallops <ul style="list-style-type: none"> • Omit scallops 	<ul style="list-style-type: none"> No cost 	<ul style="list-style-type: none"> Specify <i>omit scallops</i>.
Related Products <ul style="list-style-type: none"> • Panel-mounted Universal Systems worksurface supports • Legs and columns for Universal Systems Worksurfaces • Worksurface screens • Worksurface power and communication components 		<ul style="list-style-type: none"> ▶ Page 552 ▶ Page 558 ▶ Page 571 ▶ Page 573







For Canadian Pricing

Multiply U.S. Price by the Canadian price factor.

▶ See page 1 for details.

Specification Information

• Dimensions				• Style Number	U.S. Base Prices			• Option (Add \$ to Base Price) Full-Fill Finish on Wood Group 1	• Dimensions				• Style Number	U.S. Base Price
A	B	C	D		High-Pressure Laminate	Composite Veneer	Wood		A	B	C	D		High-Pressure Laminate
														
					• Plastic 3 mm Edge	• Composite Veneer Square Edge	• Wood Square Edge							• Plastic 3 mm Edge
					No Suffix	Suffix SW	Suffix SW							

Left-Hand With 1/2" Cord Drop

23 1/2"	23 1/2"	59 1/2"	41 1/2"	UEC2202L	\$1058	\$2241	\$2241	+\$ 93
23 1/2"	23 1/2"	65 1/2"	41 1/2"	UEC2262L	\$1158	\$2341	\$2341	+\$113
23 1/2"	23 1/2"	71 1/2"	41 1/2"	UEC2222L	\$1254	\$2437	\$2437	+\$114
23 1/2"	23 1/2"	59 1/2"	47 1/2"	UEC2208L	\$1088	\$2271	\$2271	+\$113
23 1/2"	23 1/2"	65 1/2"	47 1/2"	UEC2268L	\$1180	\$2363	\$2363	+\$114
23 1/2"	23 1/2"	71 1/2"	47 1/2"	UEC2228L	\$1274	\$2457	\$2457	+\$120
23 1/2"	29 1/2"	59 1/2"	47 1/2"	UEC2308L	\$1187	\$2370	\$2370	+\$114
23 1/2"	29 1/2"	65 1/2"	47 1/2"	UEC2368L	\$1282	\$2465	\$2465	+\$120
23 1/2"	29 1/2"	71 1/2"	47 1/2"	UEC2328L	\$1384	\$2567	\$2567	+\$122
29 1/2"	23 1/2"	59 1/2"	47 1/2"	UEC3208L	\$1187	\$2370	\$2370	+\$114
29 1/2"	23 1/2"	65 1/2"	47 1/2"	UEC3268L	\$1282	\$2465	\$2465	+\$120
29 1/2"	23 1/2"	71 1/2"	47 1/2"	UEC3228L	\$1384	\$2567	\$2567	+\$122
29 1/2"	29 1/2"	59 1/2"	47 1/2"	UEC3308L	\$1242	\$2425	\$2425	+\$120
29 1/2"	29 1/2"	65 1/2"	47 1/2"	UEC3368L	\$1343	\$2526	\$2526	+\$122
29 1/2"	29 1/2"	71 1/2"	47 1/2"	UEC3328L	\$1437	\$2620	\$2620	+\$125

With Full Depth

24"	24"	60"	42"	WEC226042	\$1058			
24"	24"	72"	42"	WEC227242	\$1254			
24"	24"	60"	48"	WEC226048	\$1088			
24"	24"	72"	48"	WEC227248	\$1274			
24"	30"	60"	42"	WEC236042	\$1109			
24"	30"	72"	42"	WEC237242	\$1315			
24"	30"	60"	48"	WEC236048	\$1187			
24"	30"	72"	48"	WEC237248	\$1384			
30"	24"	60"	42"	WEC326042	\$1109			
30"	24"	72"	42"	WEC327242	\$1315			
30"	24"	60"	48"	WEC326048	\$1187			
30"	24"	72"	48"	WEC327248	\$1384			
30"	30"	60"	42"	WEC336042	\$1174			
30"	30"	72"	42"	WEC337242	\$1366			
30"	30"	60"	48"	WEC336048	\$1242			
30"	30"	72"	48"	WEC337248	\$1437			

Universal Systems Worksurfaces





► Specification Information, continued on next page

For Canadian Pricing
 Multiply U.S. Price by the Canadian price factor.
 ► See page 1 for details.

Extended Corner, Curved-Front Worksurfaces, High-Pressure Laminate or Wood Veneer, continued

► Specification Information, continued from previous page

Specification Information

• Dimensions				• Style Number	U.S. Base Prices			• Option (Add \$ to Base Price)	• Dimensions				• Style Number	U.S. Base Price
A	B	C	D		High-Pressure Laminate	Composite Veneer	Wood		A	B	C	D		High-Pressure Laminate
								• Full-Fill Finish on Wood Group 1						
					• Plastic 3 mm Edge	• Composite Veneer Square Edge	• Wood Square Edge							
					No Suffix	Suffix SW	Suffix SW							

Right-Hand With 1/2" Cord Drop

23 1/2"	23 1/2"	41 1/2"	59 1/2"	UEC2220R	\$1058	\$2241	\$2241	+\$ 93
23 1/2"	23 1/2"	41 1/2"	65 1/2"	UEC2226R	\$1158	\$2341	\$2341	+\$113
23 1/2"	23 1/2"	41 1/2"	71 1/2"	UEC2222R	\$1254	\$2437	\$2437	+\$114
23 1/2"	23 1/2"	47 1/2"	59 1/2"	UEC2280R	\$1088	\$2271	\$2271	+\$113
23 1/2"	23 1/2"	47 1/2"	65 1/2"	UEC2286R	\$1180	\$2363	\$2363	+\$114
23 1/2"	23 1/2"	47 1/2"	71 1/2"	UEC2282R	\$1274	\$2457	\$2457	+\$120
23 1/2"	29 1/2"	47 1/2"	59 1/2"	UEC2380R	\$1187	\$2370	\$2370	+\$114
23 1/2"	29 1/2"	47 1/2"	65 1/2"	UEC2386R	\$1282	\$2465	\$2465	+\$120
23 1/2"	29 1/2"	47 1/2"	71 1/2"	UEC2382R	\$1384	\$2567	\$2567	+\$122
29 1/2"	23 1/2"	47 1/2"	59 1/2"	UEC3280R	\$1187	\$2370	\$2370	+\$114
29 1/2"	23 1/2"	47 1/2"	65 1/2"	UEC3286R	\$1282	\$2465	\$2465	+\$120
29 1/2"	23 1/2"	47 1/2"	71 1/2"	UEC3282R	\$1384	\$2567	\$2567	+\$122
29 1/2"	29 1/2"	47 1/2"	59 1/2"	UEC3380R	\$1242	\$2425	\$2425	+\$120
29 1/2"	29 1/2"	47 1/2"	65 1/2"	UEC3386R	\$1343	\$2526	\$2526	+\$122
29 1/2"	29 1/2"	47 1/2"	71 1/2"	UEC3382R	\$1437	\$2620	\$2620	+\$125

With Full Depth

24"	24"	42"	60"	WEC224260	\$1058
24"	24"	42"	72"	WEC224272	\$1254
24"	24"	48"	60"	WEC224860	\$1088
24"	24"	48"	72"	WEC224872	\$1274
24"	30"	42"	60"	WEC234260	\$1109
24"	30"	42"	72"	WEC234272	\$1315
24"	30"	48"	60"	WEC234860	\$1187
24"	30"	48"	72"	WEC234872	\$1384
30"	24"	42"	60"	WEC324260	\$1109
30"	24"	42"	72"	WEC324272	\$1315
30"	24"	48"	60"	WEC324860	\$1187
30"	24"	48"	72"	WEC324872	\$1384
30"	30"	42"	60"	WEC334260	\$1174
30"	30"	42"	72"	WEC334272	\$1366
30"	30"	48"	60"	WEC334860	\$1242
30"	30"	48"	72"	WEC334872	\$1437



For Canadian Pricing

Multiply U.S. Price by the Canadian price factor.

► See page 1 for details.

Corner, 120° Worksurfaces

High-Pressure Laminate or Wood Veneer

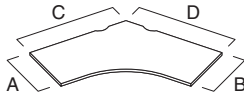

Tip: Supports must be specified separately, including side support brackets for rear corner support in panel-mounted applications.

For composite veneer, wood and laminate group 2 and 3 pricing, please refer to the electronic catalog or SmartTools.

Standard Includes		Required to Specify
<ul style="list-style-type: none"> ▶ Need help? Product details, page 208 • Worksurface: High-Pressure Laminate price group 1 or wood group 1 veneer • Laminate worksurface: <ul style="list-style-type: none"> – Plastic 3 mm edge profile on front edge – Plastic default flat profile on side and back edges • Wood worksurface: <ul style="list-style-type: none"> – Wood 3 mm edge profile on front edge – Matching veneer flat profile on side and back edges • Cable scallops on back edges 	<ul style="list-style-type: none"> 1 Style number with appropriate edge profile suffix SW Composite veneer or wood with square edge ▶ See edge profiles below. 2 High-Pressure Laminate or wood color number for worksurface 3 Plastic color number for front edge on laminate worksurface, if selected 4 Options, if selected (see below) ▶ See <i>Surface Materials</i>, page 668. 	

Options	U.S. Price	Required to Specify
Surface Materials <ul style="list-style-type: none"> • High-Pressure Laminate worksurfaces <ul style="list-style-type: none"> • Laminate price group 2 • Laminate price group 3 • Open Line laminate • Composite veneer worksurfaces <ul style="list-style-type: none"> • Composite veneer group 1 • Composite veneer group 2 • Wood veneer worksurfaces <ul style="list-style-type: none"> • Wood group 2 • Wood group 3 • Customiz stain • Full-fill finish on wood group 1 	<ul style="list-style-type: none"> See information at left See information at left +\$102 plus cost of laminate Prices below See information at left See information at left No cost Prices below 	<ul style="list-style-type: none"> Specify laminate color number. Specify laminate color number. ▶ See <i>Surface Materials Reference Manual</i>. Specify composite veneer color number. Specify composite veneer color number. Specify wood color number. Specify wood color number. Specify with <i>Customiz stain</i>. ▶ See <i>Surface Materials Reference Manual</i>. Specify full-fill finish number.
Scallops <ul style="list-style-type: none"> • Omit scallops 	No cost	Specify <i>omit scallops</i> .
Related Products <ul style="list-style-type: none"> • Panel-mounted Universal Systems worksurface supports • Legs and columns for Universal Systems Worksurfaces • Worksurface screens • Worksurface power and communication components 		<ul style="list-style-type: none"> ▶ Page 552 ▶ Page 558 ▶ Page 571 ▶ Page 573

Specification Information

• Dimensions A B C D	• Style Number	U.S. Base Prices			• Option (Add \$ to Base Price)
		High-Pressure Laminate	Composite Veneer	Wood	
		• Plastic 3 mm Edge	• Composite Veneer Square Edge	• Wood Square Edge	
		No Suffix	Suffix SW	Suffix SW	• Full-Fill Finish on Wood Group 1

Tip: To specify 3 mm edge profile, no suffix is required. For all other edge profiles, add a suffix to the style number. (For example, **UB223636** becomes **UB223636SW** for wood with square edge profile.)

Freestanding or Panel-Mounted With 1/2" Cord Drop

23 1/2"	23 1/2"	35 1/2"	35 1/2"	UB223636	\$1129	\$2209	\$2209	+\$114
23 1/2"	23 1/2"	41 1/2"	41 1/2"	UB224242	\$1175	\$2255	\$2255	+\$120
23 1/2"	23 1/2"	47 1/2"	47 1/2"	UB224848	\$1218	\$2298	\$2298	+\$122
29 1/2"	29 1/2"	35 1/2"	35 1/2"	UB333636	\$1175	\$2255	\$2255	+\$120
29 1/2"	29 1/2"	41 1/2"	41 1/2"	UB334242	\$1218	\$2298	\$2298	+\$122
29 1/2"	29 1/2"	47 1/2"	47 1/2"	UB334848	\$1260	\$2340	\$2340	+\$125

For Canadian Pricing
Multiply U.S. Price by the Canadian price factor.
▶ See page 1 for details.

Spanner Worksurfaces

High-Pressure Laminate or Wood Veneer

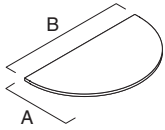

Tip: Supports for freestanding and panel-mounted applications must be specified separately.

For composite veneer, wood and laminate group 2 and 3 pricing, please refer to the electronic catalog or SmartTools.





	Standard Includes	Required to Specify
▶ Need help? Product details, page 208	<ul style="list-style-type: none"> • Worksurface: High-Pressure Laminate price group 1 or wood group 1 veneer • Laminate worksurface: <ul style="list-style-type: none"> – Plastic 3 mm edge profile on front edge – Plastic default flat profile on side and back edges • Wood worksurface: <ul style="list-style-type: none"> – Wood 3 mm edge profile on front edge – Matching veneer flat profile on side and back edges 	<ol style="list-style-type: none"> 1 Style number with appropriate edge profile suffix <ul style="list-style-type: none"> SW Composite veneer or wood with square edge ▶ See edge profiles below. 2 High-Pressure Laminate or wood color number for worksurface 3 Plastic color number for front edge on laminate worksurface, if selected 4 Options, if selected (see below) ▶ See <i>Surface Materials</i>, page 668.

	Options	U.S. Price	Required to Specify
Surface Materials	High-Pressure Laminate worksurfaces		
	<ul style="list-style-type: none"> • Laminate price group 2 • Laminate price group 3 • Open Line laminate 	See information at left See information at left +\$102 plus cost of laminate	Specify laminate color number. Specify laminate color number. ▶ See <i>Surface Materials Reference Manual</i> .
	Composite veneer worksurfaces		
	<ul style="list-style-type: none"> • Composite veneer group 1 • Composite veneer group 2 	Prices at right See information at left	Specify composite veneer color number. Specify composite veneer color number.
	Wood veneer worksurfaces		
	<ul style="list-style-type: none"> • Wood group 2 • Wood group 3 • Customiz stain 	See information at left See information at left No cost	Specify wood color number. Specify wood color number. Specify with <i>Customiz stain</i> . ▶ See <i>Surface Materials Reference Manual</i> .
	<ul style="list-style-type: none"> • Full-fill finish on wood group 1 	Prices at right	Specify full-fill finish number.
Related Products	<ul style="list-style-type: none"> • Panel-mounted Universal Systems worksurface supports • Legs and columns for Universal Systems Worksurfaces • Columns • Worksurface screens • Worksurface power and communication components 		<ul style="list-style-type: none"> ▶ Page 552 ▶ Page 558 ▶ Page 560 ▶ Page 571 ▶ Page 573



For Canadian Pricing
 Multiply U.S. Price by the Canadian price factor.
 ▶ See page 1 for details.

Specification Information

		U.S. Base Prices							U.S. Base Price
		High-Pressure Laminate	Composite Veneer	Wood			High-Pressure Laminate		
									
Dimensions	Style Number	Plastic 3 mm Edge	Composite Veneer Square Edge	Wood Square Edge	Option (Add \$ to Base Price)	Dimensions	Style Number	Plastic 3 mm Edge	
A	B	No Suffix	Suffix SW 310/24	Suffix SW 310/24	Full-Fill Finish on Wood Group 1	A	B		

For Freestanding Applications without Panels With 1/2" Cord Drop							Full Depth			
29 1/2"	47"	USPC47	\$629	\$1624	\$1624	+\$88	24"	48"	WSPC4824	\$629
35 1/2"	59"	USPC59	\$802	\$1797	\$1797	+\$98	30"	60"	WSPC6030	\$802

With 3" Notch for Use with Answer Panels						
25 1/2"	51"	WSPC5126	\$629	N.A.	N.A.	N.A.
31 1/2"	51"	USPC51	\$629	\$1624	\$1624	+\$88
31 1/2"	63"	WSPC6332	\$802	N.A.	N.A.	N.A.
37 1/2"	63"	USPC63	\$802	\$1797	\$1797	+\$98

*Tip: To specify 3 mm edge profile, no suffix is required. For all other edge profiles, add a suffix to the style number. (For example, **USPC47** becomes **USPC47SW** for wood with square edge profile.)*

For Canadian Pricing
 Multiply U.S. Price by the Canadian price factor.
 ▶ See page 1 for details.

~~310/24~~ = Last order entry
 October 20, 2024

Bullet Peninsula Worksurfaces

High-Pressure Laminate or Wood Veneer

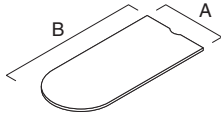

Tip: Supports for freestanding and panel-mounted applications must be specified separately.

Tip: Long work surface spans require additional support.
▶ See understanding section for details, page 209

For composite veneer, wood and laminate group 2 and 3 pricing, please refer to the electronic catalog or SmartTools.

Tip: Bullet peninsula worksurfaces are recommended for use with other curved-front shapes such as corner, curved-front worksurfaces.
▶ Page 522

Tip: The same bullet peninsula worksurfaces can be used with either worksurfaces with 1/2" cord drop or with full depth worksurfaces.

Standard Includes	Required to Specify
<ul style="list-style-type: none"> ▶ Need help? Product details, page 208 • Worksurface: High-Pressure Laminate price group 1 or wood group 1 veneer • Laminate worksurface: <ul style="list-style-type: none"> – Plastic 3 mm edge profile front edge – Plastic default flat profile on side and back edges • Wood worksurface: <ul style="list-style-type: none"> – Wood 3 mm edge profile on front edge – Matching veneer flat profile on side and back edges • Cable scallop on back edge 	<ol style="list-style-type: none"> 1 Style number with appropriate edge profile suffix SW Composite veneer or wood with square edge ▶ See edge profiles below. 2 High-Pressure Laminate or wood color number for worksurface 3 Plastic color number for front edge on laminate worksurface, if selected 4 Options, if selected (see below) ▶ See <i>Surface Materials</i>, page 668.

Surface Materials	Options	U.S. Price	Required to Specify
	High-Pressure Laminate worksurfaces		
	<ul style="list-style-type: none"> • Laminate price group 2 • Laminate price group 3 • Open Line laminate 	See information at left See information at left +\$102 plus cost of laminate	Specify laminate color number. Specify laminate color number. ▶ See <i>Surface Materials Reference Manual</i> .
	Composite veneer worksurfaces		
	<ul style="list-style-type: none"> • Composite veneer group 1 • Composite veneer group 2 	Prices below See information at left	Specify composite veneer color number. Specify composite veneer color number.
	Wood veneer worksurfaces		
	<ul style="list-style-type: none"> • Wood group 2 • Wood group 3 • Customized stain 	See information at left See information at left No cost	Specify wood color number. Specify wood color number. Specify with <i>Customiz stain</i> . ▶ See <i>Surface Materials Reference Manual</i> . Specify full-fill finish number.
	<ul style="list-style-type: none"> • Full-fill finish on wood group 1 	Prices below	
Scallop	<ul style="list-style-type: none"> • Omit scallop 	No cost	Specify <i>omit scallop</i> .
Related Products	<ul style="list-style-type: none"> • Panel-mounted Universal Systems worksurface supports • Legs and columns for Universal Systems Worksurfaces • Columns • Worksurface screens • Worksurface power and communication components 		▶ Page 552 ▶ Page 558 ▶ Page 560 ▶ Page 571 ▶ Page 573

Specification Information						
• Dimensions A B		• Style Number	U.S. Base Prices			• Option (Add \$ to Base Price) • Full-Fill • Finish on • Wood • Group 1
			High-Pressure Laminate	Composite Veneer	Wood	
			• Plastic 3 mm Edge	• Composite Veneer Square Edge	• Wood Square Edge	
			No Suffix	Suffix SW	Suffix SW	
24"	47 1/2"	UPBC2448	\$736	N.A.	N.A.	N.A.
24"	59 1/2"	UPBC2460	\$748	N.A.	N.A.	N.A.
24"	65 1/2"	UPBC2466	\$771	N.A.	N.A.	N.A.
24"	71 1/2"	UPBC2472	\$787	N.A.	N.A.	N.A.
30"	47 1/2"	UPBC3048	\$855	N.A.	N.A.	N.A.
30"	59 1/2"	UPBC3060	\$872	\$1867	\$1867	+\$85
30"	65 1/2"	UPBC3066	\$889	\$1884	\$1884	+\$87
30"	71 1/2"	UPBC3072	\$908	\$1903	\$1903	+\$93

Tip: To specify 3 mm edge profile, no suffix is required. For all other edge profiles, add a suffix to the style number. (For example, **UPBC3060** becomes **UPBC3060SW** for wood with square edge profile.)

For Canadian Pricing
Multiply U.S. Price by the Canadian price factor.
▶ See page 1 for details.

Angled Peninsula Worksurfaces

High-Pressure Laminate

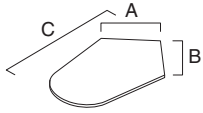

Tip: Supports for freestanding and panel-mounted applications must be specified separately.

For laminate price group 2 and 3 pricing, please refer to the electronic catalog or SmartTools.

Tip: To specify 3 mm edge profile, no suffix is required.

Standard Includes	Required to Specify
<ul style="list-style-type: none"> ▶ Need help? Product details, page 208 • Worksurface: High-Pressure Laminate price group 1 • Laminate worksurface: <ul style="list-style-type: none"> –Plastic 3 mm edge profile on front edge –Plastic default flat profile on side and back edges 	<ol style="list-style-type: none"> 1 Style number 2 High-Pressure Laminate color number for worksurface 3 Plastic color number for front edge on laminate worksurface 4 Options, if selected (see below) <p>▶ See <i>Surface Materials</i>, page 668.</p>

Options	U.S. Price	Required to Specify
Surface Materials <ul style="list-style-type: none"> • High-Pressure Laminate worksurfaces • Laminate price group 2 • Laminate price group 3 • Open Line laminate 	See information at left See information at left +\$102 plus cost of laminate	Specify laminate color number. Specify laminate color number. ▶ See <i>Surface Materials Reference Manual</i> .
Related Products <ul style="list-style-type: none"> • Panel-mounted Universal Systems worksurface supports • Legs and columns for Universal Systems Worksurfaces • Columns • Worksurface power and communication components 		▶ Page 552 ▶ Page 558 ▶ Page 560 ▶ Page 573

Universal Systems Worksurfaces

Specification Information

U.S. Base Price High-Pressure Laminate			U.S. Base Price High-Pressure Laminate		
Dimensions A B C	Style Number	Plastic 3 mm Edge	Dimensions A B C	Style Number	Plastic 3 mm Edge
With 1/2" Cord Drop			With Full Depth		
23 1/2" 23 1/2" 48"	UPA2448	\$935	24" 24" 48"	WPA2448	\$935
23 1/2" 23 1/2" 60"	UPA2460	\$979	24" 24" 60"	WPA2460	\$979
29 1/2" 29 1/2" 48"	UPA3048	\$935	30" 30" 48"	WPA3048	\$935
29 1/2" 29 1/2" 60"	UPA3060	\$979	30" 30" 60"	WPA3060	\$979

 **For Canadian Pricing**
 Multiply U.S. Price by the Canadian price factor.
 ▶ See page 1 for details.

Linking Peninsula Worksurfaces

High-Pressure Laminate or Wood Veneer

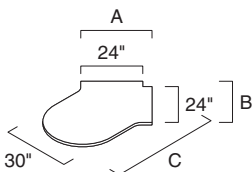

Tip: Supports for freestanding and panel-mounted applications must be specified separately.

For composite veneer, wood, and laminate group 2 and 3 pricing, please refer to the electronic catalog or SmartTools.

Tip: Linking peninsula worksurfaces are recommended for use with other curved-front shapes such as corner, curved-front worksurfaces.
▶ Page 522

Standard Includes

- ▶ Need help? Product details, page 208
- Worksurface: High-Pressure Laminate price group 1 or wood group 1 veneer
- Laminate worksurface:
 - Plastic 3 mm edge profile on front edge
 - Plastic default flat profile on side and back edges
- Wood worksurface:
 - Wood 3 mm edge profile on front edge
 - Matching veneer flat profile on side and back edges

Required to Specify

- 1 Style number with appropriate edge profile suffix
SW Composite veneer or wood with square edge
▶ See edge profiles below.
- 2 High-Pressure Laminate or wood color number for worksurface
- 3 Plastic color number for front edge on laminate worksurface, if selected
- 4 Options, if selected (see below)
▶ See *Surface Materials*, page 668.

Options

Surface Materials	High-Pressure Laminate worksurfaces	U.S. Price	Required to Specify
	<ul style="list-style-type: none"> • Laminate price group 2 • Laminate price group 3 • Open Line laminate 	See information at left See information at left +\$102 plus cost of laminate	Specify laminate color number. Specify laminate color number. ▶ See <i>Surface Materials Reference Manual</i> .
	Composite veneer worksurfaces <ul style="list-style-type: none"> • Composite veneer group 1 • Composite veneer group 2 	Prices below See information at left	Specify composite veneer color number. Specify composite veneer color number.
	Wood veneer worksurfaces <ul style="list-style-type: none"> • Wood group 2 • Wood group 3 • Customiz stain 	See information at left See information at left No cost	Specify wood color number. Specify wood color number. Specify with <i>Customiz stain</i> . ▶ See <i>Surface Materials Reference Manual</i> .
	<ul style="list-style-type: none"> • Full-fill finish on wood group 1 	Prices below	Specify full-fill finish number.

Related Products		
<ul style="list-style-type: none"> • Panel-mounted Universal Systems worksurface supports • Legs and columns for Universal Systems Worksurfaces • Columns • Worksurface power and communication components 	<ul style="list-style-type: none"> ▶ Page 552 ▶ Page 558 ▶ Page 560 ▶ Page 573 	

Specification Information

U.S. Base Prices

High-Pressure Laminate	Composite Veneer	Wood

Tip: To specify 3 mm edge profile, no suffix is required. For all other edge profiles, add a suffix to the style number. (For example, **UPAC2748** becomes **UPAC2748SW** for wood with square edge profile.)

• Dimensions A B C	• Style Number	• Plastic 3 mm Edge	• Composite Veneer Square Edge	• Wood Square Edge	• Option (Add \$ to Base Price) • Full-Fill Finish on Wood Group 1
		No Suffix	Suffix SW \$10/24	Suffix SW \$10/24	
.....

With 3" Notch for Use with Answer Panels With 1/2" Cord Drop

27"	27"	50"	UPAC2748	\$935	\$1930	\$1930	+\$80
.....

For Canadian Pricing
Multiply U.S. Price by the Canadian price factor.
▶ See page 1 for details.

\$10/24 = Last order entry
October 20, 2024

Jetty Worksurfaces

High-Pressure Laminate or Wood Veneer

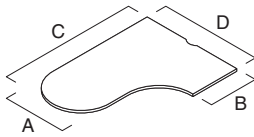

Tip: Supports for freestanding and panel-mounted applications must be specified separately.

Tip: Long worksurface spans require additional support.

▶ See understanding section for details, page 208

For composite veneer, wood and laminate group 2 and 3 pricing, please refer to the electronic catalog or SmartTools.

Tip: Jetty worksurfaces are recommended for use with other curved-front shapes such as corner, curved-front worksurfaces.

▶ Page 522

Standard Includes	Required to Specify
<ul style="list-style-type: none"> ▶ Need help? Product details, page 208 • Worksurface: High-Pressure Laminate price group 1 or wood group 1 veneer • Laminate worksurface: <ul style="list-style-type: none"> – Plastic 3 mm edge profile on front edge – Plastic default flat profile on side and back edges • Wood worksurface: <ul style="list-style-type: none"> – Wood 3 mm edge profile on front edge – Matching veneer flat profile on side and back edges • Cable scallop on back edge 	<ol style="list-style-type: none"> 1 Style number with appropriate edge profile suffix <ul style="list-style-type: none"> SW Composite veneer or wood with square edge ▶ See edge profiles below. 2 High-Pressure Laminate or wood color number for worksurface 3 Plastic color number for front edge on laminate worksurface, if selected 4 Options, if selected (see below) ▶ See <i>Surface Materials</i>, page 668.

Options	U.S. Price	Required to Specify
Surface Materials <ul style="list-style-type: none"> • High-Pressure Laminate worksurfaces <ul style="list-style-type: none"> • Laminate price group 2 See information at left • Laminate price group 3 See information at left • Open Line laminate +\$102 plus cost of laminate • Composite veneer worksurfaces <ul style="list-style-type: none"> • Composite veneer group 1 Prices at right • Composite veneer group 2 See information at left • Wood veneer worksurfaces <ul style="list-style-type: none"> • Wood group 2 See information at left • Wood group 3 See information at left • Customiz stain No cost • Full-fill finish on wood group 1 Prices at right 		<ul style="list-style-type: none"> Specify laminate color number. Specify laminate color number. ▶ See <i>Surface Materials Reference Manual</i>. Specify composite veneer color number. Specify composite veneer color number. Specify wood color number. Specify wood color number. Specify <i>with Customiz stain</i>. ▶ See <i>Surface Materials Reference Manual</i>. Specify full-fill finish number.
Scallop <ul style="list-style-type: none"> • Omit scallop 	No cost	Specify <i>omit scallop</i> .
Related Products <ul style="list-style-type: none"> • Panel-mounted Universal Systems worksurface supports • Legs and columns for Universal Systems Worksurfaces • Columns • Worksurface screens • Worksurface power and communication components 		<ul style="list-style-type: none"> ▶ Page 552 ▶ Page 558 ▶ Page 560 ▶ Page 571 ▶ Page 573







For Canadian Pricing

Multiply U.S. Price by the Canadian price factor.

▶ See page 1 for details.

Specification Information

• Dimensions				• Style Number	U.S. Base Prices			• Option (Add \$ to Base Price) Full-Fill Finish on Wood Group 1	• Dimensions				• Style Number	U.S. Base Price
A	B	C	D		High-Pressure Laminate	Composite Veneer	Wood		A	B	C	D		High-Pressure Laminate
														
					• Plastic 3 mm Edge	• Composite Veneer Square Edge	• Wood Square Edge							• Plastic 3 mm Edge
					No Suffix	Suffix SW	Suffix SW							

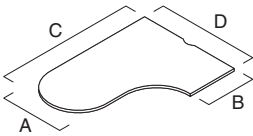

Left-Hand With 1/2" Cord Drop

30"	23 1/2"	65 1/2"	48"	UJC3268L	\$1239	\$2234	\$2234	+\$113
30"	23 1/2"	71 1/2"	48"	UJC3228L	\$1282	\$2525	\$2525	+\$119
30"	23 1/2"	77 1/2"	48"	UJC3288L	\$1325	\$2613	\$2613	+\$125
30"	29 1/2"	65 1/2"	48"	UJC3368L	\$1281	\$2276	\$2276	+\$113
30"	29 1/2"	71 1/2"	48"	UJC3328L	\$1325	\$2568	\$2568	+\$119
30"	29 1/2"	77 1/2"	48"	UJC3388L	\$1370	\$2658	\$2658	+\$125

Left-Hand With Full Depth

30"	24"	66"	48"	WJ326648L	\$1239
30"	24"	72"	48"	WJ327248L	\$1282
30"	24"	78"	48"	WJ327848L	\$1325
30"	30"	66"	48"	WJ336648L	\$1281
30"	30"	72"	48"	WJ337248L	\$1325
30"	30"	78"	48"	WJ337848L	\$1370

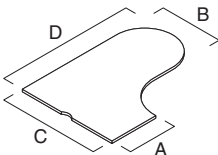

Right-Hand With 1/2" Cord Drop

23 1/2"	30"	48"	65 1/2"	UJC2386R	\$1239	\$2234	\$2234	+\$113
23 1/2"	30"	48"	71 1/2"	UJC2382R	\$1282	\$2525	\$2525	+\$119
23 1/2"	30"	48"	77 1/2"	UJC2388R	\$1325	\$2613	\$2613	+\$125
29 1/2"	30"	48"	65 1/2"	UJC3386R	\$1281	\$2276	\$2276	+\$113
29 1/2"	30"	48"	71 1/2"	UJC3382R	\$1325	\$2568	\$2568	+\$119
29 1/2"	30"	48"	77 1/2"	UJC3388R	\$1370	\$2658	\$2658	+\$125

Right-Hand With Full Depth

24"	30"	48"	66"	WJ234866R	\$1239
24"	30"	48"	72"	WJ234872R	\$1282
24"	30"	48"	78"	WJ234878R	\$1325
30"	30"	48"	66"	WJ334866R	\$1281
30"	30"	48"	72"	WJ334872R	\$1325
30"	30"	48"	78"	WJ334878R	\$1370

Tip: To specify 3 mm edge profile, no suffix is required. For all other edge profiles, add a suffix to the style number. (For example, **UJC3268L** becomes **UJC3268LSW** for wood with square edge profile.)



For Canadian Pricing

Multiply U.S. Price by the Canadian price factor.

▶ See page 1 for details.

Bubble Jetty Worksurfaces

High-Pressure Laminate or Wood Veneer

Tip: Supports for freestanding and panel-mounted applications must be specified separately.

Standard Includes	Required to Specify
<ul style="list-style-type: none"> ▶ Need help? Product details, page 208 • Worksurface: High-Pressure Laminate price group 1 or wood group 1 veneer • Laminate worksurface: <ul style="list-style-type: none"> – Plastic 3 mm edge profile on front edge – Plastic default flat profile on side and back edges • Wood worksurface: <ul style="list-style-type: none"> – Wood 3 mm edge profile on front edge – Matching veneer flat profile on side and back edges 	<ol style="list-style-type: none"> 1 Style number with appropriate edge profile suffix <ul style="list-style-type: none"> SW Composite veneer or wood with square edge ▶ See edge profiles below. 2 High-Pressure Laminate color number for worksurface 3 Plastic color number for front edge 4 Options, if selected (see below) ▶ See <i>Surface Materials</i>, page 668.

For composite veneer, wood and laminate group 2 and 3 pricing, please refer to the electronic catalog or SmartTools.

Options	U.S. Price	Required to Specify
Surface Materials		
High-Pressure Laminate worksurfaces		
• Laminate price group 2	See information at left	Specify laminate color number. Specify laminate color number. ▶ See <i>Surface Materials Reference Manual</i> .
• Laminate price group 3	See information at left	
• Open Line laminate	+\$102 plus cost of laminate	
Composite veneer worksurfaces		
• Composite veneer group 1	Prices at right	Specify composite veneer color number. Specify composite veneer color number.
• Composite veneer group 2	See information at left	
Wood veneer worksurfaces		
• Wood group 2	See information at left	Specify wood color number. Specify wood color number. Specify <i>with Customiz stain</i> . ▶ See <i>Surface Materials Reference Manual</i> . Specify full-fill finish number.
• Wood group 3	See information at left	
• Customiz stain	No cost	
• Full-fill finish on wood group 1	Prices at right	
Related Products		
• Panel-mounted Universal Systems worksurface supports		▶ Page 552
• Legs and columns for Universal Systems Worksurfaces		▶ Page 558
• Columns		▶ Page 560
• Worksurface power and communication components		▶ Page 573



For Canadian Pricing

Multiply U.S. Price by the Canadian price factor.

▶ See page 1 for details.

Specification Information

Tip: To specify 3 mm edge profile, no suffix is required. For all other edge profiles, add a suffix to the style number. (For example, **UJBC2430L** becomes **UJBC2430LSW** for wood with square edge profile.

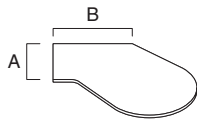
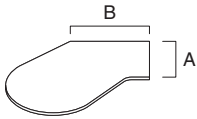

• Dimensions A B		• Style Number	U.S. Base Prices			• Option (Add \$ to Base Price) • Full-Fill Finish on Wood Group 1
			High-Pressure Laminate	Composite Veneer	Wood	
			• Plastic 3 mm Edge	• Composite Veneer Square Edge	• Wood Square Edge	
			No Suffix	Suffix SW	Suffix SW	

Left-Hand With 1/2" Cord Drop

23 1/2" 30"	UJBC2430L	\$1164	\$2159	\$2159	+\$59
23 1/2" 36"	UJBC2436L	\$1235	\$2230	\$2230	+\$62
23 1/2" 42"	UJBC2442L	\$1309	\$2304	\$2304	+\$78
23 1/2" 48"	UJBC2448L	\$1380	\$2375	\$2375	+\$78

Right-Hand With 1/2" Cord Drop

23 1/2" 30"	UJBC2430R	\$1164	\$2159	\$2159	+\$59
23 1/2" 36"	UJBC2436R	\$1235	\$2230	\$2230	+\$62
23 1/2" 42"	UJBC2442R	\$1309	\$2304	\$2304	+\$78
23 1/2" 48"	UJBC2448R	\$1380	\$2375	\$2375	+\$78

 **For Canadian Pricing**
Multiply U.S. Price by the Canadian price factor.
▶ See page 1 for details.

Visitor and Linking Worksurfaces

High-Pressure Laminate or Wood Veneer

Tip: Supports for freestanding and panel-mounted applications must be specified separately.

Tip: Visitor and linking worksurfaces are recommended for use with other curved-front shapes such as corner, curved-front worksurfaces.
▶ Page 522

For composite veneer, wood and laminate group 2 and 3 pricing, please refer to the electronic catalog or SmartTools.

Tip: Scallops are available only on visitor worksurfaces 36"W and wider.



	Standard Includes	Required to Specify
▶ Need help? Product details, page 208	<ul style="list-style-type: none"> • Worksurface: High-Pressure Laminate price group 1 or wood group 1 veneer • Laminate worksurface: <ul style="list-style-type: none"> – Plastic 3 mm edge profile on front edge – Plastic default flat profile on side and back edges • Wood worksurface: <ul style="list-style-type: none"> – Wood 3 mm edge profile on front edge – Matching veneer flat profile on side and back edges • Cable scallop on back edge of visitor worksurfaces 36"W and wider 	<ol style="list-style-type: none"> 1 Style number with appropriate edge profile suffix <ul style="list-style-type: none"> ▶ SW Composite veneer or wood with square edge ▶ See edge profiles at right. 2 High-Pressure Laminate or wood color number for worksurface 3 Plastic color number for front edge on laminate worksurface, if selected 4 Options, if selected (see below) <ul style="list-style-type: none"> ▶ See <i>Surface Materials</i>, page 668.

	Options	U.S. Price	Required to Specify
Surface Materials	High-Pressure Laminate worksurfaces		
	• Laminate price group 2	See information at left	Specify laminate color number.
	• Laminate price group 3	See information at left	Specify laminate color number.
	• Open Line laminate	+\$102 plus cost of laminate	▶ See <i>Surface Materials Reference Manual</i> .
	Composite veneer worksurfaces		
	• Composite veneer group 1	Prices at right	Specify composite veneer color number.
	• Composite veneer group 2	See information at left	Specify composite veneer color number.
	Wood veneer worksurfaces		
• Wood group 2	See information at left	Specify wood color number.	
• Wood group 3	See information at left	Specify wood color number.	
• Customiz stain	No cost	Specify <i>with Customiz stain</i> .	
• Full-fill finish on wood group 1	Prices at right	▶ See <i>Surface Materials Reference Manual</i> . Specify full-fill finish number.	
Scallop	• Omit scallop	No cost	Specify <i>omit scallop</i> .
Related Products	• Panel-mounted Universal Systems worksurface supports		▶ Page 552
	• Legs and columns for Universal Systems Worksurfaces		▶ Page 558



For Canadian Pricing
Multiply U.S. Price by the Canadian price factor.
▶ See page 1 for details.

Specification Information

			U.S. Base Prices						
			High-Pressure Laminate	Composite Veneer	Wood				
									
Dimensions	Style		Plastic	Composite	Wood	Option	Dimensions	Style	U.S. Base Price
A	B	Number	3 mm Edge	Veneer Square Edge	Square Edge	(Add \$ to Base Price)	A	B	High-Pressure Laminate
			No Suffix	Suffix SW	Suffix SW	Full-Fill Finish on Wood Group 1			
				X10/24	X10/24				

Universal Systems Worksurfaces

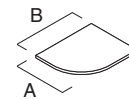
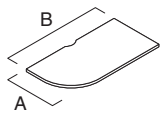

Visitor Worksurfaces With 1/2" Cord Drop

Left-Hand Worksurfaces

Dimensions A	Dimensions B	Style Number	High-Pressure Laminate	Composite Veneer	Wood	Option
23 1/2"	24"	UVC2424L	\$605	\$1600	\$1600	+\$55
23 1/2"	30"	UVC2430L	\$650	N.A.	N.A.	N.A.
23 1/2"	36"	UVC2436L	\$695	N.A.	N.A.	N.A.
23 1/2"	42"	UVC2442L	\$739	N.A.	N.A.	N.A.
23 1/2"	48"	UVC2448L	\$777	N.A.	N.A.	N.A.
29 1/2"	30"	UVC3030L	\$668	\$1687	\$1687	+\$55

With Full Depth

Left-Hand Worksurfaces

Dimensions A	Dimensions B	Style Number	High-Pressure Laminate
24"	24"	WVC2424L	\$605
24"	30"	WVC2430L	\$650
30"	30"	WVC3030L	\$668

► Specification Information, continued on next page





For Canadian Pricing
 Multiply U.S. Price by the Canadian price factor.
 ► See page 1 for details.

X10/24 = Last order entry
 October 20, 2024

Visitor and Linking Worksurfaces, High-Pressure Laminate or Wood Veneer, continued

► Specification Information, continued from previous page

Specification Information

• Dimensions A B		• Style Number	U.S. Base Prices			• Dimensions A B		• Style Number	• U.S. Base Price High- Pressure Laminate
			High- Pressure Laminate	Composite Veneer	Wood				
									
			• Plastic 3 mm Edge	• Composite Veneer Square Edge	• Wood Square Edge			• Plastic 3 mm Edge	
			No Suffix	Suffix SW X10/24	Suffix SW X10/24				
					• Option (Add \$ to Base Price)				
					• Full-Fill Finish on Wood Group 1				

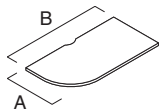

Visitor Worksurfaces With 1/2" Cord Drop, continued

Left-Hand Worksurfaces

29 1/2"	36"	UVC3036L	\$717	N.A.	N.A.	N.A.
29 1/2"	42"	UVC3042L	\$760	N.A.	N.A.	N.A.
29 1/2"	48"	UVC3048L	\$806	N.A.	N.A.	N.A.
:	:	:	:	:	:	:

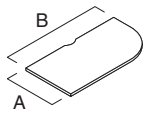

Right-Hand Worksurfaces

23 1/2"	24"	UVC2424R	\$605	\$1600	\$1600	+\$55
23 1/2"	30"	UVC2430R	\$650	N.A.	N.A.	N.A.
23 1/2"	36"	UVC2436R	\$695	N.A.	N.A.	N.A.
23 1/2"	42"	UVC2442R	\$739	N.A.	N.A.	N.A.
23 1/2"	48"	UVC2448R	\$777	N.A.	N.A.	N.A.
29 1/2"	30"	UVC3030R	\$668	\$1687	\$1687	+\$55
29 1/2"	36"	UVC3036R	\$717	N.A.	N.A.	N.A.
29 1/2"	42"	UVC3042R	\$760	N.A.	N.A.	N.A.
29 1/2"	48"	UVC3048R	\$806	N.A.	N.A.	N.A.
:	:	:	:	:	:	:

With Full Depth

:	:	:	:	:	:	:
:	:	:	:	:	:	:
:	:	:	:	:	:	:
:	:	:	:	:	:	:

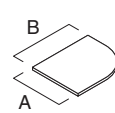

Right-Hand Worksurfaces

24"	24"	WVC2424R	\$605
24"	30"	WVC2430R	\$650
:	:	:	:
30"	30"	WVC3030R	\$668
:	:	:	:

► Specification Information, continued on next page



For Canadian Pricing





Multiply U.S. Price by the Canadian price factor.

► See page 1 for details.

X10/24 = Last order entry
October 20, 2024

► Specification Information, continued from previous page

Specification Information

			U.S. Base Prices						U.S. Base Price
			High-Pressure Laminate	Composite Veneer	Wood				High-Pressure Laminate
									
Dimensions	Style		Plastic	Composite	Wood	Option	Dimensions	Style	Plastic
A	B	Number	3 mm	Veneer	Square	(Add \$ to	A	Number	3 mm
			Edge	Square	Edge	Base Price)			Edge
				Edge		Full-Fill			
			No Suffix	Suffix SW	Suffix SW	Finish on			
				X10/24	X10/24	Wood			
						Group 1			

Universal Systems Worksurfaces

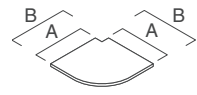
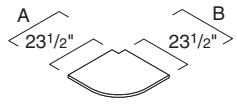

Linking Worksurfaces

With 3" Notch for Use with Answer Panels						
27"	27"	ULC2727	\$787	\$1782	\$1782	+\$55
:	:	:	:	:	:	:

With Full Depth

With 3" Notch for Use with Answer Panels			
24"	27"	WLC2727	\$787
30"	33"	WLC3333	\$846
:	:	:	:

 **For Canadian Pricing**
Multiply U.S. Price by the Canadian price factor.
► See page 1 for details.

X10/24 = Last order entry
October 20, 2024

Transaction Worksurfaces

High-Pressure Laminate or Wood Veneer



	Standard Includes	Required to Specify
<p>▶ Need help? Product details, page 220</p>	<ul style="list-style-type: none"> • Worksurface: High-Pressure Laminate price group 1 or wood group 1 veneer • Laminate worksurface: <ul style="list-style-type: none"> — Plastic 3 mm edge profile on all edges • Wood worksurface: <ul style="list-style-type: none"> — Wood 3 mm edge profile on all edges • Top caps for use with Answer panels, if selected: paint • Support brackets: black paint only 	<ol style="list-style-type: none"> 1 Style number with appropriate edge profile suffix <ul style="list-style-type: none"> SW Composite veneer or wood with square edge ▶ See edge profiles at right. 2 High-Pressure Laminate or wood color number for worksurface 3 Plastic color number for edges on laminate worksurface, if selected 4 Paint color number for top caps, if selected 5 Options, if selected (see below) ▶ See <i>Surface Materials</i>, page 668.

For composite veneer, wood and laminate group 2 and 3 pricing, please refer to the electronic catalog or SmartTools.

Tip: To specify 3 mm edge profile, no suffix is required. For all other edge profiles, add a suffix to the style number. (For example UTR1636TA becomes UTR1636TASA for wood with square edge profile.)

	Options	U.S. Price	Required to Specify
Surface Materials	High-Pressure Laminate worksurfaces		
	<ul style="list-style-type: none"> • Laminate price group 2 • Laminate price group 3 • Open Line laminate 	<ul style="list-style-type: none"> See information at left See information at left +\$102 plus cost of laminate 	<ul style="list-style-type: none"> Specify laminate color number. Specify laminate color number. ▶ See <i>Surface Materials Reference Manual</i>.
	Composite veneer worksurfaces		
	<ul style="list-style-type: none"> • Composite veneer group 1 • Composite veneer group 2 	<ul style="list-style-type: none"> Prices at right See information at left 	<ul style="list-style-type: none"> Specify composite veneer color number. Specify composite veneer color number.
	Wood veneer worksurfaces		
	<ul style="list-style-type: none"> • Wood group 2 • Wood group 3 • Customiz stain 	<ul style="list-style-type: none"> See information at left See information at left No cost 	<ul style="list-style-type: none"> Specify wood color number. Specify wood color number. Specify <i>with Customiz stain</i>. ▶ See <i>Surface Materials Reference Manual</i>. Specify full-fill finish number.
	<ul style="list-style-type: none"> • Full-fill finish on wood group 1 	<ul style="list-style-type: none"> Prices at right 	
	Top caps on laminate worksurfaces for use with Answer panels		
	<ul style="list-style-type: none"> • Wood • Customiz stain on wood 	<ul style="list-style-type: none"> +\$171 No cost 	<ul style="list-style-type: none"> Specify <i>with wood top cap</i> and select wood color number. Specify <i>with Customiz stain</i>.
Change-of-Height Cable Management Top Cap	For use with Answer panels with square trim		
	<ul style="list-style-type: none"> • Change-of-height at both ends, cable management 	<ul style="list-style-type: none"> +\$ 7 	<ul style="list-style-type: none"> Specify <i>with change-of-height, both ends cable management</i>.



For Canadian Pricing
 Multiply U.S. Price by the Canadian price factor.
 ▶ See page 1 for details.

Tip: To specify 3 mm edge profile, no suffix is required. For all other edge profiles, add a suffix to the style number. (For example, UTR1636A becomes UTR1636ASW for wood with square edge profile.)

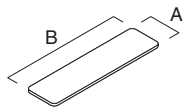

Tip: Actual width of Answer transaction worksurface using thin trim is 2" shorter than the nominal planning dimension to accommodate change of panel height applications.

Tip: Actual width of Answer transaction worksurface, using square and oval trim, is 7" shorter than the nominal planning dimension to accommodate change of panel height applications.

Specification Information

Dimensions A B	Panel Width	Style Number	U.S. Base Prices			Option (Add \$ to Base Price)
			High-Pressure Laminate	Composite Veneer	Wood	
			Plastic 3 mm Edge	Composite Veneer Square Edge	Wood Square Edge	Full-Fill Finish on Wood Group 1
			No Suffix	Suffix SW	Suffix SW	

With Brackets and Top Caps for Use with Answer Panels with Thin Trim

15"	28"	30"	UTR1630TA	\$473	N.A.	N.A.	N.A.
15"	34"	36"	UTR1636TA	\$513	\$1492	\$1492	+\$ 69
15"	40"	42"	UTR1642TA	\$552	\$1531	\$1531	+\$ 69
15"	46"	48"	UTR1648TA	\$586	\$1565	\$1565	+\$ 69
15"	58"	60"	UTR1660TA	\$635	\$1718	\$1718	+\$ 69

With Brackets and Top Caps for Use with Answer Panels with Square Trim

15"	23"	30"	UTR1630SA	\$480	N.A.	N.A.	N.A.
15"	29"	36"	UTR1636SA	\$519	\$1498	\$1498	+\$ 69
15"	35"	42"	UTR1642SA	\$561	\$1540	\$1540	+\$ 69
15"	41"	48"	UTR1648SA	\$598	\$1577	\$1577	+\$ 69
15"	53"	60"	UTR1660SA	\$647	\$1730	\$1730	+\$ 69

With Brackets and Top Caps for Use with Answer Panels with Oval Trim

15"	23"	30"	UTR1630A	\$480	N.A.	N.A.	N.A.
15"	29"	36"	UTR1636A	\$519	\$1514	\$1514	+\$ 69
15"	35"	42"	UTR1642A	\$561	\$1556	\$1556	+\$ 69
15"	41"	48"	UTR1648A	\$598	\$1593	\$1593	+\$ 69
15"	53"	60"	UTR1660A	\$647	\$1737	\$1737	+\$102

For Canadian Pricing
Multiply U.S. Price by the Canadian price factor.
▶ See page 1 for details.

Power and Data Access Door & Tray

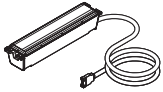

Tip: Remember to specify cutout for power and data tray on the worksurface style number.

Standard Includes	Required to Specify
<ul style="list-style-type: none"> ▶ Need help? Product details, page 212 • Door: paint • Door bezel: 6694 Slate • Inner tray with six simplex receptacles: 7237 Slate • Outer tray with end caps: 7237 Slate and 6694 Slate • Grommet (modular and hardware only): plastic • Two cord clips or harness clips 	<ul style="list-style-type: none"> 1 Style number 2 Paint color for door 3 Plastic color for grommet 4 Options, if selected (see below) ▶ See <i>Surface Materials</i>, page 668.

Surface Materials	Options	U.S. Price	Required to Specify
	Door <ul style="list-style-type: none"> • Paint • Anodized aluminum 	<ul style="list-style-type: none"> No cost +\$34 	<ul style="list-style-type: none"> Specify paint color. Specify with 8043 Clear Anodized Aluminum.
	Power Schematics, Line Options, and Ground Options	3+1 <ul style="list-style-type: none"> • Line 1 <ul style="list-style-type: none"> – System ground – Isolated ground • Line 2 <ul style="list-style-type: none"> – System ground – Isolated ground • Line 3 <ul style="list-style-type: none"> – System ground – Isolated ground • Line 4 <ul style="list-style-type: none"> – System ground – Isolated ground 	<ul style="list-style-type: none"> No cost No cost No cost No cost No cost No cost No cost No cost
	2+2 <ul style="list-style-type: none"> • Line 1 <ul style="list-style-type: none"> – System ground – Isolated ground • Line 2 <ul style="list-style-type: none"> – System ground – Isolated ground • Line 3 <ul style="list-style-type: none"> – System ground – Isolated ground • Line 4 <ul style="list-style-type: none"> – System ground – Isolated ground 	<ul style="list-style-type: none"> No cost No cost No cost No cost No cost No cost No cost No cost 	<ul style="list-style-type: none"> Specify with 2+2, line 1, system ground. Specify with 2+2, line 1, isolated ground. Specify with 2+2, line 2, system ground. Specify with 2+2, line 2, isolated ground. Specify with 2+2, line 3, system ground. Specify with 2+2, line 3, isolated ground. Specify with 2+2, line 4, system ground. Specify with 2+2, line 4, isolated ground.
	3SN <ul style="list-style-type: none"> • Line 1 <ul style="list-style-type: none"> – System ground – Isolated ground • Line 2 <ul style="list-style-type: none"> – System ground – Isolated ground • Line 3 <ul style="list-style-type: none"> – System ground – Isolated ground 	<ul style="list-style-type: none"> No cost No cost No cost No cost No cost No cost No cost No cost 	<ul style="list-style-type: none"> Specify with 3SN, line 1, system ground. Specify with 3SN, line 1, isolated ground. Specify with 3SN, line 2, system ground. Specify with 3SN, line 2, isolated ground. Specify with 3SN, line 3, system ground. Specify with 3SN, line 3, isolated ground.



For Canadian Pricing
 Multiply U.S. Price by the Canadian price factor.
 ▶ See page 1 for details.

Specification Information

Style Number	U.S. Base Price	Style Number Non-PVC	U.S. Base Price
--------------	-----------------	----------------------	-----------------

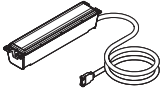

Modular Power

UTTRM	\$1574	UTTRMN	\$1589
-------	--------	--------	--------

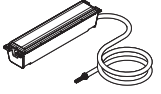

Hardwire Power

UTTRHW	\$1574	UTTRHWN	\$1589
--------	--------	---------	--------

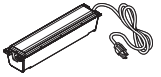

Cord and Plug

UTTRC	\$1574	UTTRCN	\$1589
-------	--------	--------	--------



For Canadian Pricing
Multiply U.S. Price by the
Canadian price factor.
▶ See page 1 for details.

Metal Center Drawers

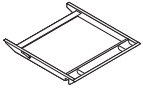

Standard Includes	Required to Specify
-------------------	---------------------

- | | | |
|----------------------------------------------|-----------------------------------------------------------------------------------------------------------------------------------------|---------------------------------------------------------------------------------------------------------------------------------------------------------------------|
| ▶ Need help?
Product details,
page 219 | <ul style="list-style-type: none"> • Center drawer: all paint price groups • Mounting frame: Grey V2 paint only | <ul style="list-style-type: none"> 1 Style number 2 Paint color number for center drawer ▶ See <i>Surface Materials</i>, page 668. |
|----------------------------------------------|-----------------------------------------------------------------------------------------------------------------------------------------|---------------------------------------------------------------------------------------------------------------------------------------------------------------------|

Specification Information				
• Dimensions			• Style	• U.S.
D	W	H	Number	Price

23"	21 1/2"	2 3/8"	FCD20	\$363
18 1/8"	21 1/2"	2 3/8"	FSCD20	\$368



For Canadian Pricing
 Multiply U.S. Price by the
 Canadian price factor.
 ▶ See page 1 for details.

Connectors



Tip: Branching harness-to-harness connectors can be used to connect two modular harness together.

Standard Includes	Required to Specify
-------------------	---------------------

- | | | |
|------------------------------------------------------------------------------------------|-----------------------------------------------------------------------------------|---------------------|
| <ul style="list-style-type: none"> ▶ Need help? Product details, page 213 | <ul style="list-style-type: none"> • Connector: black plastic only | <p>Style number</p> |
|------------------------------------------------------------------------------------------|-----------------------------------------------------------------------------------|---------------------|

Specification Information		
Description	Style Number	U.S. Price

Description	Style Number	U.S. Price
-------------	--------------	------------

4-Circuit, 3+1

Harness-to-harness	BHHCX	\$ 83
Branching harness-to-harness	GQTUHCX	\$126
:	:	:

4-Circuit, 2+2

Harness-to-harness	BHHCY	\$ 83
Branching harness-to-harness	GQTUHCY	\$126
:	:	:

3-Circuit, Separate Neutrals

Harness-to-harness	BHHCZ	\$ 83
Branching harness-to-harness	GQTUHCZ	\$126
:	:	:

Universal Systems Worksurfaces

For Canadian Pricing
 Multiply U.S. Price by the Canadian price factor.
 ▶ See page 1 for details.

Filler Package–Data



Standard Includes	Required to Specify
<ul style="list-style-type: none"> ▶ Need help? Product details, page 213 • Package of 20 fillers: black 	<ul style="list-style-type: none"> Style number

Specification Information	
• Style Number	• U.S. Price
FMVF	\$51
•	•



For Canadian Pricing
 Multiply U.S. Price by the Canadian price factor.
 ▶ See page 1 for details.

Worksurface-Mounted Retractable Power and Data

Field-Installed Cut-Out

Worksurface-Mounted
Retractable Power and Data

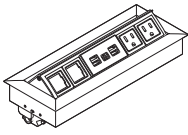

Tip: Worksurface-mounted retractable power and data requires a 4" x 11" hole with square corners in the worksurface.

Standard Includes		Required to Specify
<ul style="list-style-type: none"> ▶ Need help? Product details, page 218 	<ul style="list-style-type: none"> • Worksurface-mounted power and data openings • 10' power cord with three-prong plug: black plastic • Four power receptacles, two data openings, and faceplates provided to accommodate customer-supplied voice/data jacks • Duplex receptacles: black plastic only • Surrounding housing: anodized aluminum 	<ul style="list-style-type: none"> 1 Style number 2 Options, if selected (see below)

Options	U.S. Price	Required to Specify
Power/Data/ USB Hub	<ul style="list-style-type: none"> • 2 power, 2 data, and 1 USB Hub +\$138 • 3 power, 1 data, and 1 USB Hub +\$183 	<ul style="list-style-type: none"> Specify with 2 power + 2 data + 1 USB hub. Specify with 3 power + 1 data + 1 USB hub.

Specification Information	
Style Number	U.S. Base Price
TSTERPDWR	\$688

Universal Systems Worksurfaces

 **For Canadian Pricing**
Multiply U.S. Price by the Canadian price factor.
▶ See page 1 for details.

Panel-Mounted Universal Systems Worksurface Supports

For Use with Answer Panels

Cantilevers

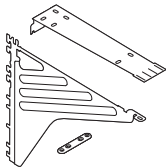

Tip: Answer panel junctions can accommodate only one cantilever at a seam.

Tip: Cantilevered straight worksurfaces greater than 26"D and 30"D transition worksurfaces require additional floor support along the front edge, such as a pedestal, end panel, post leg, side support bracket, or an adjacent return worksurface.

Standard Includes		Required to Specify
▶ Need help? Product details, page 222	<ul style="list-style-type: none"> • Cantilever: paint • Tie plate • Attachment hardware 	1 Style number 2 Paint color number for cantilever ▶ See <i>Surface Materials</i> , page 668.

Specification Information

• Style Number	• U.S. Price

On-Module Cantilever

UCANT	\$162

Side Support Brackets



Tip: Side support bracket includes a pair of handed brackets, only one of which is required for rear corner support of panel-mounted corner worksurfaces. Specify one for every two corner worksurfaces in on-module applications. Order an additional supply for off-module fin wall applications.

Standard Includes		Required to Specify
▶ Need help? Product details, page 222	<ul style="list-style-type: none"> • Pair of handed side support brackets: black paint only • Attachment hardware 	Style number

Specification Information

• Style Number	• U.S. Price

USSBR	\$58

Support Plate

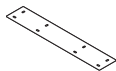

Tip: Support plate can also be used in freestanding applications.

Standard Includes		Required to Specify
▶ Need help? Product details, page 222	<ul style="list-style-type: none"> • Support plate: black paint only • Attachment hardware 	Style number

Specification Information

• Dimensions	• Style Number	• U.S. Price

14"D	TS714WSP	\$109
------	-----------------	-------

20"D	TS720WSP	\$109

 **For Canadian Pricing**
 Multiply U.S. Price by the Canadian price factor.
 ▶ See page 1 for details.

Tie Plates



Standard Includes	Required to Specify
<ul style="list-style-type: none"> • Package of six tie plates: black paint only • Attachment hardware 	Style number

Specification Information		
• Dimensions	• Style Number	• U.S. Price
39/4"L	TS7TIEPLATE	\$158
•	•	•

Reinforcing Channels

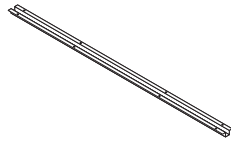

Tip: Reinforcing channel can also be used in free-standing applications.

Standard Includes	Required to Specify
<ul style="list-style-type: none"> ▶ Need help? Product details, page 202 • Reinforcing channel: black paint only • Attachment hardware 	Style number

Specification Information		
• Dimensions	• Style Number	• U.S. Price
39"W	TS7WKSPT39	\$76
48"W	TS7WKSPT48	\$76
51"W	TS7WKSPT51	\$76
54"W	TS7WKSPT54	\$76
57"W	TS7WKSPT	\$76
60"W	TS7WKSPT60	\$76
63"W	TS7WKSPT63	\$76
66"W	TS7WKSPT66	\$76
72"W	TS7WKSPT72	\$76
•	•	•

 **For Canadian Pricing**
Multiply U.S. Price by the Canadian price factor.
▶ See page 1 for details.

Panel-Mounted Universal Systems Worksurface Supports For Use with Answer Panels, continued

Center Support Panels

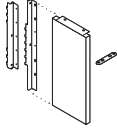

Standard Includes		Required to Specify
▶ Need help? Product details, page 222	<ul style="list-style-type: none"> Center support panel: paint price group 1 Tie plate Attachment hardware 	1 Style number 2 Paint color number for center support panel 3 Options, if selected (see below) ▶ See <i>Surface Materials</i> , page 668.

Options	U.S. Price	Required to Specify
Surface Materials	<ul style="list-style-type: none"> Paint price group 1: No cost Paint price group 2: +\$19 Paint price group 3: +\$33 	Specify paint color number. Specify paint color number. Specify paint color number.

Specification Information			
Dimensions		Style Number	U.S. Base Price
D	H		

On-Module Center Support Panel

11"	28½"	UCSP	\$210
Standing Height			
11"	40⅞"	UCSPS	\$245

End Panels

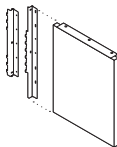

Standard Includes		Required to Specify
▶ Need help? Product details, page 222	<ul style="list-style-type: none"> End panel: paint price group 1 Attachment hardware 	1 Style number 2 Paint color number for end panel 3 Options, if selected (see below) ▶ See <i>Surface Materials</i> , page 668.

Options	U.S. Price	Required to Specify
Surface Materials	<ul style="list-style-type: none"> Paint price group 1: No cost Paint price group 2: +\$45 Paint price group 3: +\$74 	Specify paint color number. Specify paint color number. Specify paint color number.

Specification Information			
Dimensions		Style Number	U.S. Base Price
D	H		

On-Module End Panel

24"	28½"	UEP24	\$574
30"	28½"	UEP30	\$653
Standing Height			
24"	40⅞"	UEP24S	\$679
30"	40⅞"	UEP30S	\$762

 **For Canadian Pricing**
 Multiply U.S. Price by the Canadian price factor.
 ▶ See page 1 for details.

Off-Module Worksurface-to-Panel Connector

Off-Module Worksurface-to-Panel Connector



Standard Includes		Required to Specify
<ul style="list-style-type: none"> ▶ Need help? Product details, page 224 	<ul style="list-style-type: none"> • Connector: paint • Attachment hardware 	<ul style="list-style-type: none"> 1 Style number 2 Paint color number for connector 3 Options, if selected (see below) ▶ See <i>Surface Materials</i>, page 668.

Options	U.S. Price	Required to Specify
Surface Materials <ul style="list-style-type: none"> • Paint price group 1 • Paint price group 2 • Paint price group 3 	No cost +\$16 +\$34	Specify paint color. Specify paint color. Specify paint color.

Specification Information		
Width	Style Number	U.S. Base Price
24"	UFS24ANS	\$182
30"	UFS30ANS	\$201
36"	UFS36ANS	\$216
42"	UFS42ANS	\$231
48"	UFS48ANS	\$246
60"	UFS60ANS	\$384
72"	UFS72ANS	\$403
:	:	:

Universal Systems Worksurfaces



For Canadian Pricing
 Multiply U.S. Price by the Canadian price factor.
 ▶ See page 1 for details.

FrameOne Legs and Supports for Universal Worksurfaces

Standard Includes	Required to Specify
<ul style="list-style-type: none"> ▶ Need help? Product details, page 226 • Legs and intermediate support: paint • Attachment hardware 	<ul style="list-style-type: none"> 1 Style number 2 Paint color number for legs and support 3 Options, if selected (see below) ▶ See <i>Surface Materials</i>, page 668.

Surface Materials	Options	U.S. Price	Required to Specify
	For legs		
	<ul style="list-style-type: none"> • Paint price group 1 • Paint price group 2 • Paint price group 3 	<ul style="list-style-type: none"> No cost +\$28 per leg +\$51 per leg 	<ul style="list-style-type: none"> Specify paint color. Specify paint color. Specify paint color.
	For intermediate support		
	<ul style="list-style-type: none"> • Paint price group 1 • Paint price group 2 • Paint price group 3 	<ul style="list-style-type: none"> No cost +\$19 per leg +\$33 per leg 	<ul style="list-style-type: none"> Specify paint color. Specify paint color. Specify paint color.
Intermediate Support bracing	For laminate or wood storage tops		
	<ul style="list-style-type: none"> • No brace 	No cost	Specify with no brace.
	For steel storage tops		
	<ul style="list-style-type: none"> • One brace (30", 36", or 42"W) • Two braces (30", 36", or 42"W) 	<ul style="list-style-type: none"> +\$77 +\$77 	<ul style="list-style-type: none"> Specify with one brace. Specify with two braces.

Specification Information									
Dimensions	Style	U.S.	Style	U.S.	Style	U.S.	Style	U.S.	Style
D	H	Base Price	Number	Base Price	Number	Base Price	Number	Base Price	Number

Closed Loop

		Panel Supporting Left-Hand	U.S. Base Price	Panel Supporting Right-Hand	U.S. Base Price	Tethered Application	U.S. Base Price	Table Application	U.S. Base Price
24"	28½"	UFC24LHANS	\$897	UFC24RHANS	\$897	UFC24	\$897	UFC24T	\$975
30"	28½"	UFC30LHANS	\$897	UFC30RHANS	\$897	UFC30	\$897	UFC30T	\$975

Open Loop

24"	28½"	UFQ24LHANS	\$654	UFQ24RHANS	\$654	UFQ24	\$654	UFQ24T	\$732
30"	28½"	UFQ30LHANS	\$654	UFQ30RHANS	\$654	UFQ30	\$654	UFQ30T	\$732

Half Loop

24"	28½"	UFH24LHANS	\$569	UFH24RHANS	\$569				
30"	28½"	UFH30LHANS	\$569	UFH30RHANS	\$569				

Post Leg

N.A.	28½"	UFP	\$257						
------	------	------------	-------	--	--	--	--	--	--

Intermediate Support

For Use with One-High Universal Storage

16"	11⅞"	UFS1610H	\$397						
-----	------	-----------------	-------	--	--	--	--	--	--

For Use with 1.5-High Universal Storage

16"	5⅛"	UFS1615H	\$364						
-----	-----	-----------------	-------	--	--	--	--	--	--

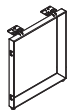

Infills for FrameOne Legs for Universal Worksurfaces

Infills for FrameOne
Legs for Universal
Worksurfaces



For composite veneer, laminate price group 2 and 3 pricing, please refer to the electronic catalog or SmartTools.

Standard Includes	Required to Specify
<ul style="list-style-type: none"> ▶ Need help? Product details, page 229 • High-Pressure Laminate price group 1 infills • Edge on laminate infill, if selected: plastic • Brackets and caps 	<ul style="list-style-type: none"> 1 Style number 2 Laminate color number for infill 3 Plastic color number for edge on laminate infill, if selected 4 Options, if selected (see below) ▶ See <i>Surface Materials</i>, page 668.

Options	U.S. Price	Required to Specify
Surface Materials		
High-Pressure Laminate		
<ul style="list-style-type: none"> • Laminate price group 2 • Laminate price group 3 • Open Line laminate 	<ul style="list-style-type: none"> See information at left See information at left +\$102 plus cost of laminate 	<ul style="list-style-type: none"> Specify laminate color number. Specify laminate color number. ▶ See <i>Surface Materials Reference Manual</i>.
Composite veneer		
<ul style="list-style-type: none"> • Composite veneer group 1 • Composite veneer group 2 	<ul style="list-style-type: none"> Prices below See information at left 	<ul style="list-style-type: none"> Specify composite veneer color number. Specify composite veneer color number.
Wood veneer		
<ul style="list-style-type: none"> • Wood group 1 • Wood group 2 • Wood group 3 • Customiz stain 	<ul style="list-style-type: none"> Prices below +\$153 +\$534 No cost 	<ul style="list-style-type: none"> Specify <i>with wood veneer</i> and indicate wood color number. Specify wood color number. Specify wood color number. Specify <i>with Customiz stain</i>. ▶ See <i>Surface Materials Reference Manual</i>.

Specification Information			
Planning Width	Style Number	U.S. Base Price	Options (Add \$ to Base Price)
..	..	High-Pressure Laminate	Composite Veneer Group 1 ; Wood Veneer Group 1

For Closed Loop Legs

Planning Width	Style Number	U.S. Base Price	Options (Add \$ to Base Price)	U.S. Price
24"W	UFC24NF	\$879	+\$282	+\$282
30"W	UFC30NF	\$979	+\$308	+\$308
..

For Open Loop Legs

Planning Width	Style Number	U.S. Base Price	Options (Add \$ to Base Price)	U.S. Price
24"W	UFQ24NF	\$879	+\$282	+\$282
30"W	UFQ30NF	\$979	+\$308	+\$308
..

For Canadian Pricing
Multiply U.S. Price by the Canadian price factor.
▶ See page 1 for details.

Legs and Columns for Universal Systems Worksurfaces

Without Alignment Tab

Post Legs and Double Post Legs

Tip: Height dimensions listed are nominal and include the thickness of a worksurface.

Tip: Standing height legs can be used as column support in panel-mounted applications only.

Tip: Corner worksurfaces require a leg in the back corner. Be sure to order fifth leg if specifying a package of four.

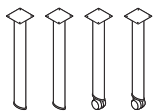

Standard Includes	Required to Specify
-------------------	---------------------

<ul style="list-style-type: none"> ▶ Need help? Product details, page 230 	<ul style="list-style-type: none"> • Legs: paint • Attachment hardware • Non-locking caster, if selected: black plastic only 	<ul style="list-style-type: none"> 1 Style number 2 Paint color number for leg 3 Options, if selected (see below) ▶ See <i>Surface Materials</i>, page 668.
---------------------------------------------------------------------------------------------------	---------------------------------------------------------------------------------------------------------------------------------------------------------------	-------------------------------------------------------------------------------------------------------------------------------------------------------------------------------------------------------

Options	U.S. Price	Required to Specify
---------	------------	---------------------

Surface Materials <ul style="list-style-type: none"> • Paint price group 1 • Paint price group 2 • Paint price group 3 	No cost +\$29 per leg +\$51 per leg	Specify paint color number. Specify paint color number. Specify paint color number.
----------------------------------------------------------------------------------------------------------------------------------------------------------------	-------------------------------------------	-------------------------------------------------------------------------------------------

Specification Information					
Planning Height	Style Number	U.S. Base Price	Planning Height	Style Number	U.S. Base Price

Post Leg with Glide

26"	UNPL	\$190
28½"	UPL	\$190
407/8"	UHPL	\$239
:	:	:

Package of Four Post Legs with Glides

26"	UNPL4	\$760
28½"	UPL4	\$760
:	:	:

Post Leg with Caster

26"	UNPLC	\$216
28½"	UPLC	\$216
:	:	:

Package of Four Post Legs with Casters

26"	UNPL4C	\$864
28½"	UPL4C	\$864
:	:	:

Package of Four Post Legs with Two Glides and Two Casters

26"	UNPL4M	\$812
28½"	UPL4M	\$812
:	:	:

▶ **Specification Information, continued on next page**



For Canadian Pricing

Multiply U.S. Price by the Canadian price factor.

▶ See page 1 for details.

► Specification Information, continued from previous page

Specification Information

Planning Height	Style Number	U.S. Base Price
-----------------	--------------	-----------------

Double Post Leg with Glides

28½"	UDPL	\$533
40⅞"	UHDPL	\$626

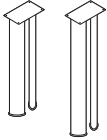

Tip: Double post legs can be used as a shared or column support in applications with other post legs.

Double Post C-Leg with Glides

28½"	UCL	\$606
------	------------	-------

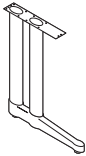

Adjustable-Height Legs

Tip: Corner worksurfaces require a leg in the back corner. Be sure to order fifth leg if specifying a package of four.

Tip: See Table and Leg Combinations page for number of legs required per worksurface.
► Page 255

Tip: Height dimensions listed include the thickness of a worksurface.

Standard Includes

- Need help? Product details, page 230
- Worksurface legs: paint
- Glides, if selected: paint to match legs
- Locking casters, if selected: paint to match legs
- Attachment hardware

Required to Specify

- 1 Style number
- 2 Paint color number for leg
- 3 Options, if selected (see below)
- See *Surface Materials*, page 668.

Options

Surface Materials	Options	U.S. Price	Required to Specify
	• Paint price group 1 • Paint price group 2	No cost +\$29 per leg	Specify paint color number. Specify paint color number.

Specification Information

Planning Height	Style Number	U.S. Base Price	Planning Height	Style Number	U.S. Base Price
-----------------	--------------	-----------------	-----------------	--------------	-----------------

Adjustable-Height Leg with Glide

25½"–31½"	UADJ	\$312
-----------	-------------	-------

Package of Four Adjustable-Height Legs with Glides

25½"–31½"	UADJ4	\$1248
-----------	--------------	--------



Adjustable-Height Leg with Caster

25½"–31½"	UADJC	\$349
-----------	--------------	-------

Package of Four Adjustable-Height Legs with Casters

25½"–31½"	UADJ4C	\$1396
-----------	---------------	--------



Package of Four Adjustable-Height Legs with Two Glides and Two Casters

25½"–31½"	UADJ4M	\$1322
-----------	---------------	--------

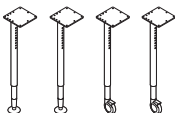

Legs and Columns for Universal Systems Worksurfaces without Alignment Tab, continued

Columns

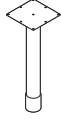

Tip: Columns have a different aesthetic than post legs (round vs. elliptical). Columns can be used as column supports in applications without post legs.

Tip: Height dimensions listed include the thickness of a worksurface.

Standard Includes	Required to Specify
<ul style="list-style-type: none"> ▶ Need help? Product details, page 230 • Column: paint • Attachment hardware 	<ul style="list-style-type: none"> 1 Style number 2 Paint color number for column 3 Options, if selected (see below) ▶ See <i>Surface Materials</i>, page 668.

Options	U.S. Price	Required to Specify
Surface Materials <ul style="list-style-type: none"> • Paint price group 1 • Paint price group 2 • Paint price group 3 	No cost +\$29 per leg +\$51 per leg	Specify paint color number. Specify paint color number. Specify paint color number.

Specification Information		
Planning Height	Style Number	U.S. Base Price
28½"	UCOL	\$420
28½"–31⅝"	UADJCOL	\$517

Tapered Post Legs

Standard Includes	Required to Specify
<ul style="list-style-type: none"> ▶ Need help? Product details, page 230 • Tapered leg: paint • Leveling glides • Attachment hardware 	<ul style="list-style-type: none"> 1 Style number 2 Paint color number for tapered legs 3 Options, if selected (see below) ▶ See <i>Surface Materials</i>, page 668.

Options	U.S. Price	Required to Specify
Surface Materials <ul style="list-style-type: none"> • Paint price group 1 • Paint price group 2 	No cost +\$17 per leg	Specify paint color number. Specify paint color number.

Specification Information		
Planning Height	Style Number	U.S. Base Price
28½"	TSTT27M	\$220

Tapered Leg		
28½"	TSTT27M	\$220

Package of Four Tapered Legs		
28½"	TSTT27M4	\$778

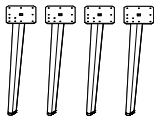

For Canadian Pricing
 Multiply U.S. Price by the Canadian price factor.
 ▶ See page 1 for details.

Specifying Worksurface Screens

Universal Privacy/Modesty Screens	563
Universal Privacy Screens and Aligners	564
Sarto Privacy/Modesty Screens	566
Sarto Privacy Screens	568
Sarto Alignment Bracket	570
Worksurface Screens	571

Universal Privacy/Modesty Screens

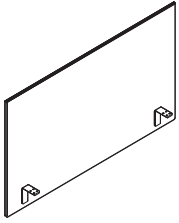

Tip: Universal privacy/modesty screens can be attached to 3/4"–1 1/2" thick worksurface, including height adjustable work-surfaces, universal work-surfaces, and Elective Elements work-surfaces.

Tip: The screens weigh between 9.79 lb and 11.89 lb. Take this into consideration when planning for use on height-adjustable work-surfaces.

Tip: The universal privacy/modesty screen is intended for use on the back of a worksurface.

Tip: Fabric is applied horizontally on the screen.

Tip: Screen allows for 1 1/8" cord drop or no cord drop. See understanding pages for product specific application guidelines.

Standard Includes		Required to Specify
<ul style="list-style-type: none"> ▶ Need help? Product details, page 236 	<ul style="list-style-type: none"> • Screen: fabric price group 1 • Brackets: 7360 Merle • Edge: PET 	<ol style="list-style-type: none"> 1 Style number 2 Width (see below under Required Selections) 3 Mount location (see below under Required Selections) 4 Fabric color number for screen 5 Edge color: <ul style="list-style-type: none"> P630 Medium Heather Grey PET P631 Dark Heather Grey PET 6 Options, if selected (see below) <p>▶ See <i>Surface Materials</i>, page 668.</p>

	Required Selections	U.S. Price	Required to Specify
Width	<ul style="list-style-type: none"> • 42"W • 48"W • 54"W • 60"W • 66"W 	Prices below Prices below Prices below Prices below Prices below	Specify width. Specify width. Specify width. Specify width. Specify width.
Mount Location	<ul style="list-style-type: none"> • Privacy (19 1/8" above the worksurface, 5 1/2" below the worksurface) • Privacy/modesty (13" above the worksurface, 11 7/10" below the worksurface) 	No cost No cost	Specify with privacy application. Specify with privacy/modesty application.

	Options	U.S. Price	Required to Specify
Surface Materials	<ul style="list-style-type: none"> • Fabric price group 1 • Fabric price group 2 • Fabric price group 3 • Fabric price group 4 • Fabric price group 5 • Fabric price group 6 • Fabric price group 7 • Fabric price group 8 • Fabric price group 9 • Fabric price group 10 • Customer's Own Material (COM) 	No cost +\$ 57 +\$161 +\$205 +\$246 +\$288 +\$334 +\$375 +\$417 +\$459 +\$ 23	Specify fabric color number. Specify fabric color number. Specify fabric color number. Specify fabric color number. Specify fabric color number. Specify fabric color number. Specify fabric color number. Specify fabric color number. Specify fabric color number. Specify fabric color number. Specify fabric color number. ▶ See <i>Surface Materials Reference Manual</i> .

Specification Information		
Style Number	Width	U.S. Base Prices
UFPM	42"	\$677
	48"	\$719
	54"	\$765
	60"	\$812
	66"	\$857



For Canadian Pricing
 Multiply U.S. Price by the Canadian price factor.
 ▶ See page 1 for details.



Universal Privacy Screens and Aligners

Universal Privacy Screens

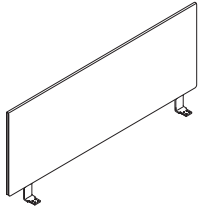

Standard Includes	Required to Specify
<ul style="list-style-type: none"> ▶ Need help? Product details, page 238 • Screen: fabric price group 1 • Brackets: paint price group 1 • Edge: PET 	<ol style="list-style-type: none"> 1 Style number 2 Width (see below under Required Selections) 3 Height (see below under Required Selections) 4 Fabric color number for screen 5 Bracket finish color number 6 Edge color: <ul style="list-style-type: none"> P630 Medium Heather Grey PET P631 Dark Heather Grey PET 7 Options, if selected (see below) <ul style="list-style-type: none"> ▶ See <i>Surface Materials</i>, page 668.

	Required Selections	U.S. Price	Required to Specify
Width	<ul style="list-style-type: none"> • 24"W • 30"W • 36"W • 42"W • 48"W • 54"W • 60"W • 66"W • 72"W • 78"W • 84"W • 90"W • 96"W 	<ul style="list-style-type: none"> Prices at right Prices at right Prices at right Prices at right Prices at right Prices at right Prices at right Prices at right Prices at right Prices at right Prices at right Prices at right Prices at right 	<ul style="list-style-type: none"> Specify width. Specify width. Specify width. Specify width. Specify width. Specify width. Specify width. Specify width. Specify width. Specify width. Specify width. Specify width. Specify width.
Height	<ul style="list-style-type: none"> • 13½"H • 19½"H 	<ul style="list-style-type: none"> Prices at right Prices at right 	<ul style="list-style-type: none"> Specify height. Specify height.

Tip: 13½"H screen will align at a 42" datum. 19½"H screen will align at a 48" datum.

	Options	U.S. Price	Required to Specify
Surface Materials	<ul style="list-style-type: none"> • Fabric price group 1 • Fabric price group 2 • Fabric price group 3 • Fabric price group 4 • Fabric price group 5 • Fabric price group 6 • Fabric price group 7 • Fabric price group 8 • Fabric price group 9 • Fabric price group 10 • Customer's Own Material (COM) 	<ul style="list-style-type: none"> No cost +\$ 49 +\$132 +\$165 +\$203 +\$237 +\$274 +\$307 +\$343 +\$378 +\$ 23 	<ul style="list-style-type: none"> Specify fabric color number. Specify fabric color number. Specify fabric color number. Specify fabric color number. Specify fabric color number. Specify fabric color number. Specify fabric color number. Specify fabric color number. Specify fabric color number. Specify fabric color number. Specify fabric color number. ▶ See <i>Surface Materials Reference Manual</i>.
Bracket	<ul style="list-style-type: none"> • Paint price group 1 • Paint price group 2 	<ul style="list-style-type: none"> No cost +\$ 16 	<ul style="list-style-type: none"> Specify paint color number. Specify paint color number.
Related Products	<ul style="list-style-type: none"> • Aligners 		<ul style="list-style-type: none"> ▶ See page 565



For Canadian Pricing
 Multiply U.S. Price by the Canadian price factor.
 ▶ See page 1 for details.

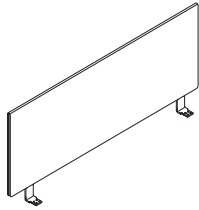

Specification Information

Style Number	Height	U.S. Base Prices							
		24"W	30"W	36"W	42"W	48"W	54"W	60"W	66"W
UFPS	13½"	\$443	\$475	\$505	\$540	\$571	\$605	\$637	\$670
	19½"	\$505	\$557	\$608	\$658	\$713	\$763	\$814	\$862

► **Specification Information, continued from above**

Style Number	Height	U.S. Base Prices				
		72"W	78"W	84"W	90"W	96"W
UFPS	13½"	\$704	\$735	\$ 766	\$ 798	\$ 831
	19½"	\$915	\$965	\$1014	\$1065	\$1112

Aligners

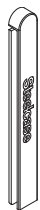

Tip: Aligners are for use with Universal screens only.

Standard Includes	Required to Specify
-------------------	---------------------

- | | | |
|----------------------------------------------------------------------------------------|--------------------------------------------------------------------------------------|----------------------------------------------------------------|
| <ul style="list-style-type: none"> Need help? Product details, page 238 | <ul style="list-style-type: none"> Aligner, package of 10: 6527 Merle | <ul style="list-style-type: none"> Style number |
|----------------------------------------------------------------------------------------|--------------------------------------------------------------------------------------|----------------------------------------------------------------|

Specification Information

Style Number	U.S. Price
UFAL	\$36

 **For Canadian Pricing**
Multiply U.S. Price by the Canadian price factor.
► See page 1 for details.

Sarto Privacy/Modesty Screens

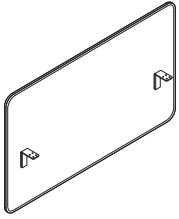

Tip: Sarto privacy/modesty screens can be attached to 3/4"-1 1/2" thick worksurface, including Ology, Migration, Elective Elements, universal tables, and universal panel-mount worksurfaces.

Tip: The screens weigh between 3.51 and 11.64 lb. Take this into consideration when planning for use on height-adjustable worksurfaces. See understanding pages to calculate screen weight.

Tip: Worksurface type option adds a fourth worksurface bracket and repositions brackets to avoid worksurface scallops.

Tip: Side screen option changes brackets to smaller L-brackets, mounting the screen mount flush to the side of the worksurface. Side screen option is only available on screens 36"W and narrower.

Standard Includes	Required to Specify
-------------------	---------------------

<ul style="list-style-type: none"> ▶ Need help? Product details, page 239 • Screen: fabric price group 1 • Brackets: 7360 Merle 	<ol style="list-style-type: none"> 1 Style number 2 Size option (see below under Required Selections) 3 Width (see below under Required Selections) 4 Height (see below under Required Selections) 5 Privacy height (see below under Required Selections) 6 Worksurface type (see below under Required Selections) 7 Screen type (see below under Required Selections) 8 Fabric color number for screen 9 Options, if selected (see below) <p>▶ See <i>Surface Materials</i>, page 668.</p>
------------------------------------------------------------------------------------------------------------------------------------------------------------------	------------------------------------------------------------------------------------------------------------------------------------------------------------------------------------------------------------------------------------------------------------------------------------------------------------------------------------------------------------------------------------------------------------------------------------------------------------------------------------------------------------------------------------------------------------------------------------

Required Selections	U.S. Price	Required to Specify
---------------------	------------	---------------------

Size Option	<ul style="list-style-type: none"> • Modular • Parametric 	No cost No cost	Specify <i>with modular</i> . Specify <i>with parametric</i> .																																										
Width	<table border="1"> <thead> <tr> <th style="background-color: #212121; color: white;">Modular</th> <th style="background-color: #212121; color: white;">Parametric</th> </tr> </thead> <tbody> <tr><td>• N.A.</td><td>23"W –28 1/16"</td></tr> <tr><td>• 24"W</td><td>N.A.</td></tr> <tr><td>• 29"W</td><td>29"W</td></tr> <tr><td>• N.A.</td><td>29 1/16"W–36"W</td></tr> <tr><td>• 42"W</td><td>36 1/16"W–42"W</td></tr> <tr><td>• 46"W</td><td>N.A.</td></tr> <tr><td>• 48"W</td><td>42 1/16"W–48"W</td></tr> <tr><td>• 54"W</td><td>48 1/16"W–54"W</td></tr> <tr><td>• 58"W</td><td>N.A.</td></tr> <tr><td>• 60"W</td><td>54 1/16"W–60"W</td></tr> <tr><td>• 66"W</td><td>60 1/16"W–66"W</td></tr> <tr><td>• 70"W</td><td>66 1/16"W–70"W</td></tr> </tbody> </table>	Modular	Parametric	• N.A.	23"W –28 1/16"	• 24"W	N.A.	• 29"W	29"W	• N.A.	29 1/16"W–36"W	• 42"W	36 1/16"W–42"W	• 46"W	N.A.	• 48"W	42 1/16"W–48"W	• 54"W	48 1/16"W–54"W	• 58"W	N.A.	• 60"W	54 1/16"W–60"W	• 66"W	60 1/16"W–66"W	• 70"W	66 1/16"W–70"W	Prices at right Prices at right Prices at right Prices at right Prices at right Prices at right Prices at right Prices at right Prices at right Prices at right Prices at right Prices at right	Specify width. Specify width. Specify width. Specify width. Specify width. Specify width. Specify width. Specify width. Specify width. Specify width. Specify width. Specify width.																
Modular	Parametric																																												
• N.A.	23"W –28 1/16"																																												
• 24"W	N.A.																																												
• 29"W	29"W																																												
• N.A.	29 1/16"W–36"W																																												
• 42"W	36 1/16"W–42"W																																												
• 46"W	N.A.																																												
• 48"W	42 1/16"W–48"W																																												
• 54"W	48 1/16"W–54"W																																												
• 58"W	N.A.																																												
• 60"W	54 1/16"W–60"W																																												
• 66"W	60 1/16"W–66"W																																												
• 70"W	66 1/16"W–70"W																																												
Height	<table border="1"> <thead> <tr> <th style="background-color: #212121; color: white;">Modular</th> <th style="background-color: #212121; color: white;">Parametric</th> </tr> </thead> <tbody> <tr><td>• 24"H</td><td>24"H</td></tr> <tr><td>• 30"H</td><td>24 1/2"H–30"H</td></tr> </tbody> </table>	Modular	Parametric	• 24"H	24"H	• 30"H	24 1/2"H–30"H	Prices at right Prices at right	Specify height. Specify height.																																				
Modular	Parametric																																												
• 24"H	24"H																																												
• 30"H	24 1/2"H–30"H																																												
Privacy Height	<table border="1"> <thead> <tr> <th style="background-color: #212121; color: white;">Screen Height</th> <th style="background-color: #212121; color: white;">Minimum Privacy Height</th> <th style="background-color: #212121; color: white;">Maximum Privacy Height</th> </tr> </thead> <tbody> <tr><td>• 24"H</td><td>9"H</td><td>16 1/2"H</td></tr> <tr><td>• 24 1/2"H</td><td>9 1/2"H</td><td>17"H</td></tr> <tr><td>• 25"H</td><td>10"H</td><td>17 1/2"H</td></tr> <tr><td>• 25 1/2"H</td><td>10 1/2"H</td><td>18"H</td></tr> <tr><td>• 26"H</td><td>11"H</td><td>18 1/2"H</td></tr> <tr><td>• 26 1/2"H</td><td>11 1/2"H</td><td>19"H</td></tr> <tr><td>• 27"H</td><td>12"H</td><td>19 1/2"H</td></tr> <tr><td>• 27 1/2"H</td><td>12 1/2"H</td><td>20"H</td></tr> <tr><td>• 28"H</td><td>13"H</td><td>20 1/2"H</td></tr> <tr><td>• 28 1/2"H</td><td>13 1/2"H</td><td>21"H</td></tr> <tr><td>• 29"H</td><td>14"H</td><td>21 1/2"H</td></tr> <tr><td>• 29 1/2"H</td><td>14 1/2"H</td><td>22"H</td></tr> <tr><td>• 30"H</td><td>15"H</td><td>22 1/2"H</td></tr> </tbody> </table>	Screen Height	Minimum Privacy Height	Maximum Privacy Height	• 24"H	9"H	16 1/2"H	• 24 1/2"H	9 1/2"H	17"H	• 25"H	10"H	17 1/2"H	• 25 1/2"H	10 1/2"H	18"H	• 26"H	11"H	18 1/2"H	• 26 1/2"H	11 1/2"H	19"H	• 27"H	12"H	19 1/2"H	• 27 1/2"H	12 1/2"H	20"H	• 28"H	13"H	20 1/2"H	• 28 1/2"H	13 1/2"H	21"H	• 29"H	14"H	21 1/2"H	• 29 1/2"H	14 1/2"H	22"H	• 30"H	15"H	22 1/2"H	No cost No cost No cost No cost No cost No cost No cost No cost No cost No cost No cost No cost	Specify privacy height. Specify privacy height. Specify privacy height. Specify privacy height. Specify privacy height. Specify privacy height. Specify privacy height. Specify privacy height. Specify privacy height. Specify privacy height. Specify privacy height. Specify privacy height.
Screen Height	Minimum Privacy Height	Maximum Privacy Height																																											
• 24"H	9"H	16 1/2"H																																											
• 24 1/2"H	9 1/2"H	17"H																																											
• 25"H	10"H	17 1/2"H																																											
• 25 1/2"H	10 1/2"H	18"H																																											
• 26"H	11"H	18 1/2"H																																											
• 26 1/2"H	11 1/2"H	19"H																																											
• 27"H	12"H	19 1/2"H																																											
• 27 1/2"H	12 1/2"H	20"H																																											
• 28"H	13"H	20 1/2"H																																											
• 28 1/2"H	13 1/2"H	21"H																																											
• 29"H	14"H	21 1/2"H																																											
• 29 1/2"H	14 1/2"H	22"H																																											
• 30"H	15"H	22 1/2"H																																											
Worksurface Type	<ul style="list-style-type: none"> • For screens 60"W or greater • Without scallop • With scallop 	No cost +\$55	Specify <i>without scallop</i> . Specify <i>with scallop</i> .																																										
Screen Type	<ul style="list-style-type: none"> • Rear screen • Side screen 	No cost No cost	Specify <i>with rear screen</i> . Specify <i>with side screen</i> .																																										

Tip: Fabric is applied horizontally on the screen.

Tip: Screen allows for 1 1/8" cord drop or no cord drop when mounted to the rear of a worksurface. See understanding pages for product specific application guidelines.

Options	U.S. Price	Required to Specify
Surface Materials		
• Fabric price group 2	+\$ 57	Specify fabric color number.
• Fabric price group 3	+\$161	Specify fabric color number.
• Fabric price group 4	+\$205	Specify fabric color number.
• Fabric price group 5	+\$246	Specify fabric color number.
• Fabric price group 6	+\$288	Specify fabric color number.
• Fabric price group 7	+\$334	Specify fabric color number.
• Fabric price group 8	+\$375	Specify fabric color number.
• Fabric price group 9	+\$417	Specify fabric color number.
• Fabric price group 10	+\$459	Specify fabric color number.
• Customer's Own Material (COM)	+\$ 23	Specify fabric color number.
		▶ See <i>Surface Materials Reference Manual</i> .

Specification Information											
Style Number	Parametric Height	Modular width	U.S. Base Prices								
			24"W	29"W	N.A.	42"W	46"W or 48"W	54"W	58"W or 60"W	66"W	70"W
		Parametric width	23"W	29"W	29 1/16"W	36 1/16"W	42 1/16"W	48 1/16"W	54 1/16"W	60 1/16"W	66 1/16"W
			-28 5/16"W	-36"W	-42"W	-48"W	-54"W	-60"W	-66"W	-70"W	

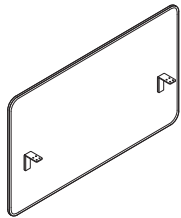

PSPM	24"	24 1/2"-30"								
	\$431	\$589	\$484	\$650	\$516	\$680	\$546	\$711	\$578	\$743
	\$611	\$777	\$644	\$812	\$678	\$845	\$711	\$876		

 **For Canadian Pricing**
Multiply U.S. Price by the Canadian price factor.
▶ See page 1 for details.

Sarto Privacy Screens

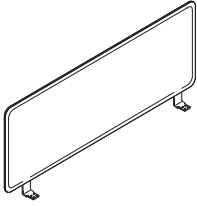

Standard Includes		Required to Specify
<ul style="list-style-type: none"> ▶ Need help? Product details, page 240 	<ul style="list-style-type: none"> • Screen: fabric price group 1 • Brackets and hard stops: 7360 Merle 	<ol style="list-style-type: none"> 1 Style number 2 Size option (see below under Required Selections) 3 Width (see below under Required Selections) 4 Height (see below under Required Selections) 5 Screen type (see below under Required Selections) 6 Fabric color number for screen 7 Options, if selected (see below) <ul style="list-style-type: none"> ▶ See <i>Surface Materials</i>, page 668.

Required Selections		U.S. Price	Required to Specify																																																																								
Size Option	<ul style="list-style-type: none"> • Modular • Parametric 	No cost No cost	Specify <i>with modular</i> . Specify <i>with parametric</i> .																																																																								
Width	<table border="1"> <thead> <tr> <th>Modular</th> <th>Parametric</th> <th>U.S. Price</th> <th>Required to Specify</th> </tr> </thead> <tbody> <tr><td>• 24"W</td><td>24"W</td><td>Prices at right</td><td>Specify width.</td></tr> <tr><td>• 29"W</td><td>N.A.</td><td>Prices at right</td><td>Specify width.</td></tr> <tr><td>• 30"W</td><td>24¹/₁₆"W–30"W</td><td>Prices at right</td><td>Specify width.</td></tr> <tr><td>• 36"W</td><td>30¹/₁₆"W–36"W</td><td>Prices at right</td><td>Specify width.</td></tr> <tr><td>• 42"W</td><td>36¹/₁₆"W–42"W</td><td>Prices at right</td><td>Specify width.</td></tr> <tr><td>• 46"W</td><td>N.A.</td><td>Prices at right</td><td>Specify width.</td></tr> <tr><td>• 48"W</td><td>42¹/₁₆"W–48"W</td><td>Prices at right</td><td>Specify width.</td></tr> <tr><td>• 54"W</td><td>48¹/₁₆"W–54"W</td><td>Prices at right</td><td>Specify width.</td></tr> <tr><td>• 58"W</td><td>N.A.</td><td>Prices at right</td><td>Specify width.</td></tr> <tr><td>• 60"W</td><td>54¹/₁₆"W–60"W</td><td>Prices at right</td><td>Specify width.</td></tr> <tr><td>• 66"W</td><td>60¹/₁₆"W–66"W</td><td>Prices at right</td><td>Specify width.</td></tr> <tr><td>• 70"W</td><td>N.A.</td><td>Prices at right</td><td>Specify width.</td></tr> <tr><td>• 72"W</td><td>66¹/₁₆"W–72"W</td><td>Prices at right</td><td>Specify width.</td></tr> <tr><td>• 78"W</td><td>72¹/₁₆"W–78"W</td><td>Prices at right</td><td>Specify width.</td></tr> <tr><td>• 84"W</td><td>78¹/₁₆"W–84"W</td><td>Prices at right</td><td>Specify width.</td></tr> <tr><td>• 90"W</td><td>84¹/₁₆"W–90"W</td><td>Prices at right</td><td>Specify width.</td></tr> <tr><td>• 96"W</td><td>90¹/₁₆"W–96"W</td><td>Prices at right</td><td>Specify width.</td></tr> </tbody> </table>	Modular	Parametric	U.S. Price	Required to Specify	• 24"W	24"W	Prices at right	Specify width.	• 29"W	N.A.	Prices at right	Specify width.	• 30"W	24 ¹ / ₁₆ "W–30"W	Prices at right	Specify width.	• 36"W	30 ¹ / ₁₆ "W–36"W	Prices at right	Specify width.	• 42"W	36 ¹ / ₁₆ "W–42"W	Prices at right	Specify width.	• 46"W	N.A.	Prices at right	Specify width.	• 48"W	42 ¹ / ₁₆ "W–48"W	Prices at right	Specify width.	• 54"W	48 ¹ / ₁₆ "W–54"W	Prices at right	Specify width.	• 58"W	N.A.	Prices at right	Specify width.	• 60"W	54 ¹ / ₁₆ "W–60"W	Prices at right	Specify width.	• 66"W	60 ¹ / ₁₆ "W–66"W	Prices at right	Specify width.	• 70"W	N.A.	Prices at right	Specify width.	• 72"W	66 ¹ / ₁₆ "W–72"W	Prices at right	Specify width.	• 78"W	72 ¹ / ₁₆ "W–78"W	Prices at right	Specify width.	• 84"W	78 ¹ / ₁₆ "W–84"W	Prices at right	Specify width.	• 90"W	84 ¹ / ₁₆ "W–90"W	Prices at right	Specify width.	• 96"W	90 ¹ / ₁₆ "W–96"W	Prices at right	Specify width.		
Modular	Parametric	U.S. Price	Required to Specify																																																																								
• 24"W	24"W	Prices at right	Specify width.																																																																								
• 29"W	N.A.	Prices at right	Specify width.																																																																								
• 30"W	24 ¹ / ₁₆ "W–30"W	Prices at right	Specify width.																																																																								
• 36"W	30 ¹ / ₁₆ "W–36"W	Prices at right	Specify width.																																																																								
• 42"W	36 ¹ / ₁₆ "W–42"W	Prices at right	Specify width.																																																																								
• 46"W	N.A.	Prices at right	Specify width.																																																																								
• 48"W	42 ¹ / ₁₆ "W–48"W	Prices at right	Specify width.																																																																								
• 54"W	48 ¹ / ₁₆ "W–54"W	Prices at right	Specify width.																																																																								
• 58"W	N.A.	Prices at right	Specify width.																																																																								
• 60"W	54 ¹ / ₁₆ "W–60"W	Prices at right	Specify width.																																																																								
• 66"W	60 ¹ / ₁₆ "W–66"W	Prices at right	Specify width.																																																																								
• 70"W	N.A.	Prices at right	Specify width.																																																																								
• 72"W	66 ¹ / ₁₆ "W–72"W	Prices at right	Specify width.																																																																								
• 78"W	72 ¹ / ₁₆ "W–78"W	Prices at right	Specify width.																																																																								
• 84"W	78 ¹ / ₁₆ "W–84"W	Prices at right	Specify width.																																																																								
• 90"W	84 ¹ / ₁₆ "W–90"W	Prices at right	Specify width.																																																																								
• 96"W	90 ¹ / ₁₆ "W–96"W	Prices at right	Specify width.																																																																								
Height	<table border="1"> <thead> <tr> <th>Modular</th> <th>Parametric</th> <th>U.S. Price</th> <th>Required to Specify</th> </tr> </thead> <tbody> <tr><td>• 13¹/₂"H</td><td>13¹/₂"H</td><td>Prices at right</td><td>Specify height.</td></tr> <tr><td>• 19¹/₂"H</td><td>14"H–19¹/₂"H</td><td>Prices at right</td><td>Specify height.</td></tr> <tr><td>• 23¹/₂"H</td><td>20"H–24"H</td><td>Prices at right</td><td>Specify height.</td></tr> <tr><td>• N.A.</td><td>24¹/₂"H–30"H</td><td>Prices at right</td><td>Specify height.</td></tr> <tr><td>• 35¹/₂"H</td><td>30¹/₂"H–35¹/₂"H</td><td>Prices at right</td><td>Specify height.</td></tr> </tbody> </table>	Modular	Parametric	U.S. Price	Required to Specify	• 13 ¹ / ₂ "H	13 ¹ / ₂ "H	Prices at right	Specify height.	• 19 ¹ / ₂ "H	14"H–19 ¹ / ₂ "H	Prices at right	Specify height.	• 23 ¹ / ₂ "H	20"H–24"H	Prices at right	Specify height.	• N.A.	24 ¹ / ₂ "H–30"H	Prices at right	Specify height.	• 35 ¹ / ₂ "H	30 ¹ / ₂ "H–35 ¹ / ₂ "H	Prices at right	Specify height.																																																		
Modular	Parametric	U.S. Price	Required to Specify																																																																								
• 13 ¹ / ₂ "H	13 ¹ / ₂ "H	Prices at right	Specify height.																																																																								
• 19 ¹ / ₂ "H	14"H–19 ¹ / ₂ "H	Prices at right	Specify height.																																																																								
• 23 ¹ / ₂ "H	20"H–24"H	Prices at right	Specify height.																																																																								
• N.A.	24 ¹ / ₂ "H–30"H	Prices at right	Specify height.																																																																								
• 35 ¹ / ₂ "H	30 ¹ / ₂ "H–35 ¹ / ₂ "H	Prices at right	Specify height.																																																																								
Screen Type	<ul style="list-style-type: none"> • Rear screen • Side screen 	No cost No cost	Specify <i>with rear screen</i> . Specify <i>with side screen</i> .																																																																								

Tip: Side screen option changes brackets to offset bayonet brackets maintaining adequate side to side pinch points. Side screen option is only available on screens 36"W and narrower.

Options	U.S. Price	Required to Specify
Surface Materials	<ul style="list-style-type: none"> • Fabric price group 2 +\$ 49 • Fabric price group 3 +\$132 • Fabric price group 4 +\$165 • Fabric price group 5 +\$203 • Fabric price group 6 +\$237 • Fabric price group 7 +\$274 • Fabric price group 8 +\$307 • Fabric price group 9 +\$343 • Fabric price group 10 +\$378 • Customer's Own Material (COM) +\$ 23 	<ul style="list-style-type: none"> Specify fabric color number. Specify fabric color number. Specify fabric color number. Specify fabric color number. Specify fabric color number. Specify fabric color number. Specify fabric color number. Specify fabric color number. Specify fabric color number. Specify fabric color number. <ul style="list-style-type: none"> ▶ See <i>Surface Materials Reference Manual</i>.



For Canadian Pricing
Multiply U.S. Price by the Canadian price factor.
▶ See page 1 for details.

Specification Information

• Style Number	• Parametric Height	• Modular Width	• U.S. Base Prices													
			24"W	29"W or 30"W	36"W	42"W	46"W or 48"W	54"W	58"W or 60"W	66"W	70"W or 72"W	78"W	84"W	90"W	96"W	
		• Parametric Width	24"W	24½"W	30½"W	36½"W	42½"W	48½"W	54½"W	60½"W	66½"W	72½"W	78½"W	84½"W	90½"W	96"W

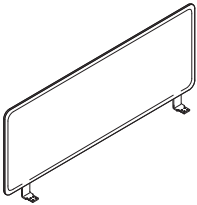

PSPS	Height	24"W	29"W or 30"W	36"W	42"W	46"W or 48"W	54"W	58"W or 60"W	66"W	70"W or 72"W	78"W	84"W	90"W	96"W
	13½"	\$324	\$348	\$372	\$395	\$420	\$446	\$470	\$493	\$518	\$ 560	\$ 583	\$ 608	\$ 632
	14"-19½"	\$370	\$408	\$446	\$484	\$521	\$558	\$596	\$632	\$673	\$ 735	\$ 770	\$ 812	\$ 847
	20"-24"	\$452	\$484	\$516	\$546	\$578	\$611	\$644	\$678	\$711	\$ 752	\$ 792	\$ 832	\$ 873
	24½"-30"	\$617	\$650	\$680	\$711	\$743	\$777	\$812	\$845	\$876	\$1088	\$1158	\$1227	\$1297
	30½"-35½"	\$701	\$734	\$764	\$795	\$827	\$859	\$892	\$925	\$960	\$1170	\$1239	\$1310	\$1380

Worksurface Screens

 **For Canadian Pricing**
 Multiply U.S. Price by the Canadian price factor.
 ▶ See page 1 for details.

Sarto Alignment Bracket

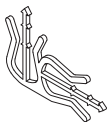

Tip: Alignment bracket is for use with Sarto privacy or Sarto privacy/modesty screens.

Tip: Alignment bracket is for Sarto screens in perpendicular applications.

Standard Includes	Required to Specify
-------------------	---------------------

- | | | |
|------------------------------------------------------------------------------------------|--------------------------------------------------------------------------------------------|---------------------|
| <ul style="list-style-type: none"> ▶ Need help? Product details, page 239 | <ul style="list-style-type: none"> • Alignment bracket: translucent plastic | <p>Style number</p> |
|------------------------------------------------------------------------------------------|--------------------------------------------------------------------------------------------|---------------------|

Specification Information	
---------------------------	--

<ul style="list-style-type: none"> • Style Number 	<ul style="list-style-type: none"> • U.S. Price
-------------------------------------------------------------------------	-----------------------------------------------------------------------

<ul style="list-style-type: none"> • PSCB 	<ul style="list-style-type: none"> • \$7
-----------------------------------------------------------------	---------------------------------------------------------



For Canadian Pricing

Multiply U.S. Price by the Canadian price factor.

▶ See page 1 for details.

Worksurface Screens

Divisio Side Screen



Tip: The Divisio side screen can be used on any 3/4"- to 1 1/2"-thick worksurface.

Tip: The Divisio side screen has an overhang of 8". This is important when planning for returns or storage.

Tip: The Divisio side screen weighs approximately 14 1/2 pounds. Take this into consideration when planning for use on height-adjustable worksurfaces.

Tip: The Divisio side screen is intended for use on the front of a worksurface.

Tip: The Divisio side screen does not work on knife edge profiles.

Standard Includes		Required to Specify
▶ Need help? Product details, page 241	<ul style="list-style-type: none"> Screen: fabric price group A Top cap and clamp: 4799 Platinum paint 	1 Style number 2 Fabric color number ▶ See <i>Surface Materials Reference Manual</i> .

Options	U.S. Price	Required to Specify
Surface Materials		
Fabric		
• Fabric price group A	No cost	Specify fabric color number.
• Fabric price group 1	No cost	Specify fabric color number.
• Fabric price group 2	+\$21	Specify fabric color number.
• Customer's Own Material (COM)	+\$23	▶ See <i>Surface Materials Reference Manual</i> .

Specification Information			
• Dimensions		• Style	• U.S.
D	H	Number	Base Price
29 1/2"	11 5/8"	DVSS2912	\$509
:	:	:	:

Worksurface Screens

 **For Canadian Pricing**
 Multiply U.S. Price by the Canadian price factor.
 ▶ See page 1 for details.



Specifying Worksurface Power and Communication

Power Sphere	574
Power and Communication Sphere	574
Power and Communication Port	574
Power/Power Box	575
2½" Round Grommet	575
Universal Worksurface Wire Managers	576
Cable and Fiber Reels	576
Termination Plate	576
Cord Reels	577
Wire Clips	577
Wire Manager	577

Wiring and Cabling Accessories

Power Sphere

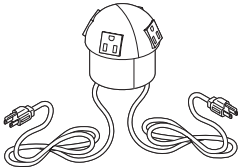

Tip: Sphere is field installed. Use 3"-diameter drill to cut mounting hole at desired location.

Standard Includes					Required to Specify
<ul style="list-style-type: none"> Sphere with four simplex electrical outlets: black plastic only Two 6' power cords (each rated at 15 amps), if selected: black plastic only 					Style number
Specification Information					
Dimensions			Style	U.S.	
D	W	H	Number	Price	
Four Electrical Outlets with Two 6' Power Cords					
3 ³ / ₈ "	3 ³ / ₈ "	3"	PTDMGB1	\$365	
.....	

Power and Communication Sphere

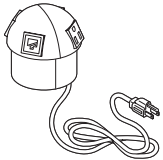

Tip: Sphere is field installed. Use 3"-diameter drill to cut mounting hole at desired location.

Tip: Faceplates in sphere accommodates standard voice/data jacks.

Standard Includes					Required to Specify
<ul style="list-style-type: none"> Sphere with two simplex electrical outlets: black plastic only Faceplates to accommodate two customer-supplied voice/data jacks: black plastic only 6' power cord with plug rated at 15 amps, if selected: black plastic only 					Style number
Specification Information					
Dimensions			Style	U.S.	
D	W	H	Number	Price	
Sphere with One 6' Power Cord					
3 ³ / ₈ "	3 ³ / ₈ "	3"	PTDMGB3	\$365	
.....	

Power and Communication Port

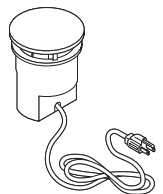

Tip: Port is field installed. Use a 3¹/₂"-diameter drill to cut mounting hole at desired location.

Standard Includes					Required to Specify
<ul style="list-style-type: none"> Port with two electrical outlets: black plastic only 6' power cord with plug rated at 15 amps: black plastic only Adapters for two customer-supplied data couplers/jacks 					Style number
Specification Information					
Dimensions			Style	U.S.	
D	W	H	Number	Price	
Port with Two Electrical Outlets and One 6' Power Cord					
4 ¹ / ₄ "	4 ¹ / ₄ "	4 ⁵ / ₁₆ "	PTRSGB1	\$541	
.....	

Power/Power Box

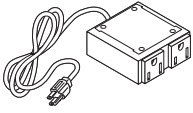

Standard Includes	Required to Specify
<ul style="list-style-type: none"> Power/power box 	Style number

Specification Information

Dimensions			Style Number	U.S. Price
D	W	H		
3"	3"	1"	AWVBP	\$340

2½" Round Grommet



Tip: Grommet AWAG2 is for use on worksurfaces only.

Tip: When using AWAG2 in the Universal parametric straight worksurface, specify the 2" grommet cutout option. Actual diameter of cutout is 2¼".

Standard Includes	Required to Specify
<ul style="list-style-type: none"> Grommet: paint or metal Installation instructions 	1 Style number 2 Paint or metal color number ▶ See <i>Surface Materials</i> , page 668.

Specification Information

Dimensions		Style Number	U.S. Price
D	W		
2½"	2½"	AWAG2	\$100

Power and Communication

3" Grommet Package



Tip: When using TSAEGROM in the Universal parametric straight worksurface, specify the 3" grommet cutout.

Standard Includes	Required to Specify
<ul style="list-style-type: none"> Package of 10 grommets: black plastic 	Style number

Specification Information

Style Number	U.S. Price
TSAEGROM	\$85

For Canadian Pricing
 Multiply U.S. Price by the Canadian price factor.
 ▶ See page 1 for details.

Universal Worksurface Wire Managers



Standard Includes	Required to Specify
<ul style="list-style-type: none"> ▶ Need help? Product details, page 211 • Set of six field installed worksurface wire managers: plastic • Attachment hardware 	<ul style="list-style-type: none"> 1 Style number 2 Plastic color number for worksurface wire manager: <ul style="list-style-type: none"> 6000 Black 6009 Arctic White 6052 Milk 6053 Seagull 6249 Platinum Solid 6654 Sand 6695 Midnight 6697 Fog

Specification Information	
• Style Number	• U.S. Price
TS7WWM	\$220

Cable and Fiber Reels

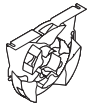

Standard Includes	Required to Specify
<ul style="list-style-type: none"> • Package of four reels: black plastic only 	<ul style="list-style-type: none"> Style number

Specification Information	
• Style Number	• U.S. Price
98766	\$244

Termination Plate



Standard Includes	Required to Specify
<ul style="list-style-type: none"> • Termination plate: black paint only 	<ul style="list-style-type: none"> Style number

Specification Information				
• Dimensions			• Style Number	• U.S. Price
D	W	H		
3/4"	7 1/8"	7 1/8"	98765	\$35



For Canadian Pricing
 Multiply U.S. Price by the Canadian price factor.
 ▶ See page 1 for details.

Cord Reels

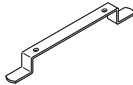

Standard Includes	Required to Specify
<ul style="list-style-type: none"> • Carton of six cord reels: black paint only 	Style number

Specification Information	
• Style Number	• U.S. Price
98767	\$107

Wire Clips



Standard Includes	Required to Specify
<ul style="list-style-type: none"> • Carton of six: black plastic only • Foam tape • Mounting screws 	Style number

Specification Information	
• Style Number	• U.S. Price
999CHT	\$106

Power and Communication

Wire Manager



Standard Includes	Required to Specify
<ul style="list-style-type: none"> • 25" wire manager with double-sided tape: black plastic 	Style number

Specification Information				
• Dimensions			• Style Number	• U.S. Price
D	W	H		
1"	3/4"	25"	AWVW	\$22

 **For Canadian Pricing**
 Multiply U.S. Price by the Canadian price factor.
 ▶ See page 1 for details.



Specifying Universal Tables



Tables	
Straight Tables	580
Capsule Tables	582
Spanner Tables	583
Peninsula Table	584
Tapered Peninsula Tables	585
Round Tables	586
Square Tables	587
Rectangle Tables	588
Oval Tables	589
Hex Conference Tables	590
Bases for Universal Tables	591
Legs for Universal Tables	592

Straight Tables

High-Pressure Laminate or Wood Veneer

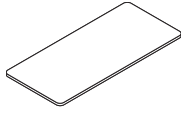

Standard Includes	Required to Specify
<ul style="list-style-type: none"> ▶ Need help? Product details, page 248 • Table: High-Pressure Laminate price group 1 or wood group 1 veneer • Laminate table: plastic 3 mm edge profile on all sides • Wood table: wood square 3 mm edge profile on all sides 	<ol style="list-style-type: none"> 1 Style number with appropriate edge profile suffix <ul style="list-style-type: none"> SW Composite veneer or wood with square edge ▶ See edge profiles at right. 2 High-Pressure Laminate or Wood color number for table 3 Plastic color number for edge on laminate table, if selected 4 Options, if selected (see below) ▶ See <i>Surface Materials</i>, page 668.

For composite veneer, wood and laminate group 2 and 3 pricing, please refer to the electronic catalog or SmartTools.

Tip: Select the reinforcing channel option if the table will be supported by legs. Channels are not required if the table will be supported by T- or X-bases.

Tip: Bases and legs to support Universal Tables must be specified separately.

Tip: For base and leg support guidelines, see Table and Base Combinations, ▶ Page 254 Table and Leg Combinations, ▶ Page 255

Options	U.S. Price	Required to Specify
Surface Materials		
High-Pressure Laminate tables		
<ul style="list-style-type: none"> • Laminate price group 2 • Laminate price group 3 • Open Line laminate 	See information at left See information at left +\$102 plus cost of laminate	Specify laminate color number. Specify laminate color number. ▶ See <i>Surface Materials Reference Manual</i> .
Composite veneer tables		
<ul style="list-style-type: none"> • Composite veneer group 1 • Composite veneer group 2 	Prices at right See information at left	Specify composite veneer color number. Specify composite veneer color number.
Wood veneer tables		
<ul style="list-style-type: none"> • Wood group 2 • Wood group 3 • Customiz stain 	See information at left See information at left No cost	Specify wood color number. Specify wood color number. Specify <i>with Customiz stain</i> . ▶ See <i>Surface Materials Reference Manual</i> . Specify full-fill finish number.
<ul style="list-style-type: none"> • Full-fill finish on wood group 1 	Prices at right	
Reinforcing Channel		
<ul style="list-style-type: none"> • Reinforcing channel (available on 66"W and wider tables) 	No cost	Specify <i>with reinforcing channel</i> .
Related Products		
<ul style="list-style-type: none"> • Worksurface screens • Worksurface power and communication components • Bases for Universal Tables • Legs for Universal Tables 		▶ Page 571 ▶ Page 573 ▶ Page 591 ▶ Page 592



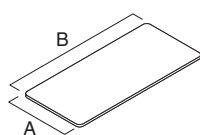

For Canadian Pricing
 Multiply U.S. Price by the Canadian price factor.
 ▶ See page 1 for details.

Tip: To specify 3 mm edge profile, no suffix is required. For other edge profiles, add suffix to the style number. (For example, BFS2430 becomes BFS2430SW for wood square edge profile.)



Specification Information

Dimensions		Style Number	U.S. Base Prices			Option (Add \$ to Base Price)
A	B		High-Pressure Laminate	Composite Veneer	Wood	
						
			Plastic 3 mm Edge	Composite Veneer Square Edge	Wood Square Edge	
			No Suffix	Suffix SW	Suffix SW	Full-Fill Finish on Wood Group 1
24"	29 3/4"	BFS2430	\$361	\$1151	\$1151	+\$55
24"	35 3/4"	BFS2436	\$385	\$1185	\$1185	+\$56
24"	41 3/4"	BFS2442	\$415	\$1316	\$1316	+\$62
24"	47 3/4"	BFS2448	\$491	\$1426	\$1426	+\$63
24"	53 3/4"	BFS2454	\$528	\$1472	\$1472	+\$66
24"	59 3/4"	BFS2460	\$567	\$1619	\$1619	+\$73
24"	65 3/4"	BFS2466	\$623	\$1707	\$1707	+\$75
24"	71 3/4"	BFS2472	\$704	\$1813	\$1813	+\$77
24"	77 3/4"	BFS2478	\$768	\$1908	\$1908	+\$78
30"	35 3/4"	BFS3036	\$532	\$1393	\$1393	+\$59
30"	41 3/4"	BFS3042	\$576	\$1530	\$1530	+\$63
30"	47 3/4"	BFS3048	\$637	\$1627	\$1627	+\$66
30"	53 3/4"	BFS3054	\$682	\$1696	\$1696	+\$69
30"	59 3/4"	BFS3060	\$734	\$1846	\$1846	+\$75
30"	65 3/4"	BFS3066	\$790	\$1939	\$1939	+\$77
30"	71 3/4"	BFS3072	\$856	\$2037	\$2037	+\$78
30"	77 3/4"	BFS3078	\$929	\$2133	\$2133	+\$81

 **For Canadian Pricing**
 Multiply U.S. Price by the Canadian price factor.
 ▶ See page 1 for details.

Capsule Tables

High-Pressure Laminate

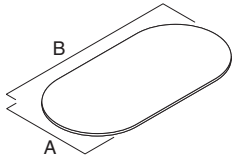

For laminate group 2 and 3 pricing, please refer to the electronic catalog or SmartTools.

Tip: Select the reinforcing channel option if the table will be supported by legs. Channels are not required if the table will be supported by T- or X-bases.

Tip: Bases and legs to support Universal Tables must be specified separately.

Tip: For leg and support guidelines, see Table and Base Combinations, ▶ Page 254 Table and Leg Combinations, ▶ Page 255

Standard Includes	Required to Specify
-------------------	---------------------

<ul style="list-style-type: none"> ▶ Need help? Product details, page 248 • Tables: High-Pressure Laminate price group 1 with plastic 3 mm edge profile 	<ol style="list-style-type: none"> 1 Style number 2 High-Pressure Laminate color number for table 3 Plastic color number for edge on laminate table 4 Options, if selected (see below) <ul style="list-style-type: none"> ▶ See <i>Surface Materials</i>, page 668.
---------------------------------------------------------------------------------------------------------------------------------------------------------------------------------	------------------------------------------------------------------------------------------------------------------------------------------------------------------------------------------------------------------------------------------------------------------------------------------------------------------------------

Options	U.S. Price	Required to Specify
---------	------------	---------------------

<p>Surface Materials</p> <ul style="list-style-type: none"> • High-Pressure Laminate tables • Laminate price group 2 • Laminate price group 3 • Open Line laminate 	<p>See information at left</p> <p>See information at left +\$102 plus cost of laminate</p>	<p>Specify laminate color number.</p> <p>Specify laminate color number.</p> <ul style="list-style-type: none"> ▶ See <i>Surface Materials Reference Manual</i>.
<p>Reinforcing Channel</p> <ul style="list-style-type: none"> • Reinforcing channel (available on 66"W and wider tables) 	<p>No cost</p>	<p>Specify with reinforcing channel.</p>
<p>Related Products</p> <ul style="list-style-type: none"> • Worksurface screens • Worksurface power and communication components • Bases for Universal Tables • Legs for Universal Tables 		<ul style="list-style-type: none"> ▶ Page 571 ▶ Page 573 ▶ Page 591 ▶ Page 592

Specification Information

• Dimensions		• Style Number	U.S. Base Prices	
			High-Pressure Laminate	
A	B			
			• Plastic 3 mm Edge	
			• No Suffix	
24"	48"	BFK2448	\$	840
30"	60"	BFK3060	\$	943
36"	72"	BFK3672	\$	1129
42"	84"	BFK4284	\$	1704
48"	96"	BFK4896	\$	2018
:	:	:	:	:



For Canadian Pricing
 Multiply U.S. Price by the Canadian price factor.
 ▶ See page 1 for details.

Spanner Tables

High-Pressure Laminate or Wood Veneer

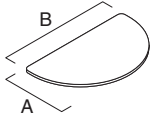

Standard Includes	Required to Specify
<ul style="list-style-type: none"> ▶ Need help? Product details, page 248 • Table: High-Pressure Laminate price group 1 or wood group 1 veneer • Laminate table: plastic 3 mm edge profile on all sides • Wood table: wood square 3 mm edge profile on all sides 	<ol style="list-style-type: none"> 1 Style number with appropriate edge profile suffix SW Composite veneer or wood with square edge 2 High-Pressure Laminate or wood color number for table 3 Plastic color number for edge on laminate table, if selected 4 Options, if selected (see below) <p>▶ See <i>Surface Materials</i>, page 668.</p>

For composite veneer, wood and laminate group 2 and 3 pricing, please refer to the electronic catalog or SmartTools.

Tip: Legs to support Universal Tables must be specified separately.

Tip: For leg and support guidelines, see Table and Leg Combinations, ▶ Page 255

*Tip: To specify 3 mm edge profile, no suffix is required. For other edge profiles, add suffix to the style number. (For example, **BFSP48** becomes **BFSP48SW** for wood square edge profile.*

Options	U.S. Price	Required to Specify
Surface Materials <ul style="list-style-type: none"> • High-Pressure Laminate tables <ul style="list-style-type: none"> • Laminate price group 2 See information at left • Laminate price group 3 See information at left • Open Line laminate +\$102 plus cost of laminate • Composite veneer tables <ul style="list-style-type: none"> • Composite veneer group 1 Prices below • Composite veneer group 2 See information at left • Wood veneer tables <ul style="list-style-type: none"> • Wood group 2 See information at left • Wood group 3 See information at left • Customiz stain No cost • Full-fill finish on wood group 1 Prices below 		Specify laminate color number. Specify laminate color number. ▶ See <i>Surface Materials Reference Manual</i> . Specify composite veneer color number. Specify composite veneer color number. Specify wood color number. Specify wood color number. Specify with <i>Customiz stain</i> . ▶ See <i>Surface Materials Reference Manual</i> . Specify full-fill finish number.
Related Products <ul style="list-style-type: none"> • Worksurface screens • Worksurface power and communication components • Legs for Universal Tables 		▶ Page 571 ▶ Page 573 ▶ Page 592

Dimensions		Style Number	U.S. Base Prices			Option (Add \$ to Base Price)
A	B		High-Pressure Laminate	Composite Veneer	Wood	
			Plastic 3 mm Edge	Composite Veneer Square Edge	Wood Square Edge	
			No Suffix	Suffix SW	Suffix SW	Full-Fill Finish on Wood Group 1
30"	48"	BFSP48	\$737	\$1832	\$1832	+\$88
30"	52"	BFSP52	\$785	\$1832	\$1832	+\$96
36"	60"	BFSP60	\$824	\$2269	\$2269	+\$97
36"	64"	BFSP64	\$868	\$2270	\$2270	+\$98

For Canadian Pricing
 Multiply U.S. Price by the Canadian price factor.
 ▶ See page 1 for details.

Peninsula Table

High-Pressure Laminate or Wood Veneer

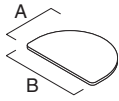

Standard Includes	Required to Specify
<ul style="list-style-type: none"> ▶ Need help? Product details, page 248 • Tables: High-Pressure Laminate price group 1 or wood group 1 veneer • Laminate table: plastic 3 mm edge profile on all sides • Wood table: wood square 3 mm edge profile on all sides 	<ol style="list-style-type: none"> 1 Style number with appropriate edge profile suffix <ul style="list-style-type: none"> SW Composite veneer or wood with square edge ▶ See edge profiles below. 2 High-Pressure Laminate or wood color number for table 3 Plastic color number for edge on laminate table, if selected 4 Options, if selected (see below) ▶ See <i>Surface Materials</i>, page 668.

For composite veneer, wood and laminate group 2 and 3 pricing, please refer to the electronic catalog or SmartTools.

Tip: Legs to support Universal Tables must be specified separately.

Tip: For leg and support guidelines, see Table and Leg Combinations, ▶ Page 255

*Tip: To specify 3 mm edge profile, no suffix is required. For other edge profiles, add suffix to the style number. (For example, **BFP2736** becomes **BFP2736SW** for wood square edge profile.)*

Options	U.S. Price	Required to Specify
Surface Materials		
High-Pressure Laminate tables		
<ul style="list-style-type: none"> • Laminate price group 2 • Laminate price group 3 • Open Line laminate 	See information at left See information at left +\$102 plus cost of laminate	Specify laminate color number. Specify laminate color number. ▶ See <i>Surface Materials Reference Manual</i> .
Composite veneer tables		
<ul style="list-style-type: none"> • Composite veneer group 1 • Composite veneer group 2 	Prices below See information at left	Specify composite veneer color number. Specify composite veneer color number.
Wood veneer tables		
<ul style="list-style-type: none"> • Wood group 2 • Wood group 3 • Customiz stain 	See information at left See information at left No cost	Specify wood color number. Specify wood color number. Specify with <i>Customiz stain</i> . ▶ See <i>Surface Materials Reference Manual</i> . Specify full-fill finish number.
<ul style="list-style-type: none"> • Full-fill finish on wood group 1 	Prices below	
Related Products		
<ul style="list-style-type: none"> • Worksurface screens • Legs for Universal Tables 		▶ Page 571 ▶ Page 592

Dimensions A B		Style Number	U.S. Base Prices			Option (Add \$ to Base Price) Full-Fill Finish on Wood Group 1
			High-Pressure Laminate Plastic 3 mm Edge No Suffix	Composite Veneer Composite Veneer Square Edge Suffix SW	Wood Wood Square Edge Suffix SW	
27"	36"	BFP2736	\$719	\$1707	\$1707	+\$86

For Canadian Pricing
 Multiply U.S. Price by the Canadian price factor.
 ▶ See page 1 for details.

Tapered Peninsula Tables

High-Pressure Laminate or Wood Veneer

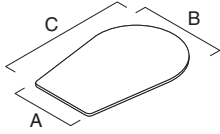

Standard Includes

▶ Need help? Product details, page 248

- Table: High-Pressure Laminate price group 1 or wood group 1 veneer
- Laminate table: plastic 3 mm edge profile on all sides
- Wood table: wood square 3 mm edge profile on all sides

Required to Specify

- 1 Style number with appropriate edge profile suffix
SW Composite veneer or wood with square edge
- ▶ See edge profiles below.
- 2 High-Pressure Laminate or wood color number for table
- 3 Plastic color number for edge on laminate table, if selected
- 4 Options, if selected (see below)
- ▶ See *Surface Materials*, page 668.

For composite veneer, wood and laminate group 2 and 3 pricing, please refer to the electronic catalog or SmartTools.

Tip: Legs to support Universal Tables must be specified separately.

Tip: For leg and support guidelines, see Table and Leg Combinations, ▶ Page 255

*Tip: To specify 3 mm edge profile, no suffix is required. For other edge profiles, add suffix to the style number. (For example, **BFTP48** becomes **BFTP48SW** for wood square edge profile.)*

Options

Surface Materials	Options	U.S. Price	Required to Specify
	High-Pressure Laminate tables		
	• Laminate price group 2	See information at left	Specify laminate color number.
	• Laminate price group 3	See information at left	Specify laminate color number.
	• Open Line laminate	+\$102 plus cost of laminate	▶ See <i>Surface Materials Reference Manual</i> .
	Composite veneer tables		
	• Composite veneer group 1	Prices below	Specify composite veneer color number.
	• Composite veneer group 2	See information at left	Specify composite veneer color number.
	Wood veneer tables		
	• Wood group 2	See information at left	Specify wood color number.
	• Wood group 3	See information at left	Specify wood color number.
	• Customiz stain	No cost	Specify with <i>Customiz stain</i> .
	• Full-fill finish on wood group 1	Prices below	▶ See <i>Surface Materials Reference Manual</i> . Specify full-fill finish number.

Related Products	Options	U.S. Price	Required to Specify
	• Worksurface screens		▶ Page 571
	• Worksurface power and communication components		▶ Page 573
	• Legs for Universal Tables		▶ Page 592

Specification Information

Dimensions			Style Number	U.S. Base Prices			Option (Add \$ to Base Price)
A	B	C		High-Pressure Laminate	Composite Veneer	Wood	
				Plastic 3 mm Edge	Composite Veneer Square Edge	Wood Square Edge	
				No Suffix	Suffix SW	Suffix SW	Full-Fill Finish on Wood Group 1
27"	32"	48"	BFTP48	\$1005	\$2308	\$2308	+\$78
33"	40"	60"	BFTP60	\$1026	\$2397	\$2397	+\$85
.....

For Canadian Pricing
Multiply U.S. Price by the Canadian price factor.
▶ See page 1 for details.

Round Tables

High-Pressure Laminate or Wood Veneer



Standard Includes	Required to Specify
<ul style="list-style-type: none"> ▶ Need help? Product details, page 248 • Table: High-Pressure Laminate price group 1 or wood group 1 veneer • Laminate table: plastic 3 mm edge profile on all sides • Wood table: wood square 3 mm edge profile on all sides 	<ol style="list-style-type: none"> 1 Style number with appropriate edge profile suffix <ul style="list-style-type: none"> K Laminate with knife edge SW Composite veneer or wood with square edge ▶ See edge profiles below. 2 High-Pressure Laminate or wood color number for table 3 Plastic color number for edge on laminate table, if selected 4 Options, if selected (see below) ▶ See <i>Surface Materials</i>, page 668.

For composite veneer, wood and laminate group 2 and 3 pricing, please refer to the electronic catalog or SmartTools.

Tip: Bases and legs to support Universal Tables must be specified separately.

Tip: For leg and support guidelines, see Table and Base Combinations, ▶ Page 254 Table and Leg Combinations, ▶ Page 255

Tip: To specify 3 mm edge profile, no suffix is required. For other edge profiles, add suffix to the style number. (For example, BFR36 becomes BFR36SW for wood square edge profile.)

Options	U.S. Price	Required to Specify
Surface Materials <ul style="list-style-type: none"> • High-Pressure Laminate tables <ul style="list-style-type: none"> • Laminate price group 2 • Laminate price group 3 • Open Line laminate • Composite veneer tables <ul style="list-style-type: none"> • Composite veneer group 1 • Composite veneer group 2 • Wood veneer tables <ul style="list-style-type: none"> • Wood group 2 • Wood group 3 • Customiz stain • Full-fill finish on wood group 1 	<ul style="list-style-type: none"> See information at left See information at left +\$102 plus cost of laminate Prices below See information at left See information at left No cost Prices below 	<ul style="list-style-type: none"> Specify laminate color number. Specify laminate color number. ▶ See <i>Surface Materials Reference Manual</i>. Specify composite veneer color number. Specify composite veneer color number. Specify wood color number. Specify wood color number. Specify <i>with Customiz stain</i>. ▶ See <i>Surface Materials Reference Manual</i>. Specify full-fill finish number.
Related Products <ul style="list-style-type: none"> • Bases for Universal Tables • Legs for Universal Tables 		<ul style="list-style-type: none"> ▶ Page 591 ▶ Page 592

Specification Information						
Diameter	Style Number	U.S. Base Prices High-Pressure Laminate		Composite Veneer	Wood	Option (Add \$ to Base Price)
		Plastic 3 mm Edge	Plastic Knife Edge	Composite Veneer Square Edge	Wood Square Edge	
		No Suffix	Suffix K	Suffix SW	Suffix SW	Full-Fill Finish on Wood Group 1
30"	BFR30	\$639	\$ 905	N.A.	N.A.	N.A.
36"	BFR36	\$683	\$ 949	\$2292	\$2292	+\$63
42"	BFR42	\$759	\$1025	\$2411	\$2411	+\$69
48"	BFR48	\$828	\$1094	\$2685	\$2685	+\$77
54"	BFR54	\$995	\$1261	\$2966	\$2966	+\$81



For Canadian Pricing
Multiply U.S. Price by the Canadian price factor.
▶ See page 1 for details.

Square Tables

High-Pressure Laminate or Wood Veneer

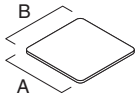

Standard Includes		Required to Specify
<ul style="list-style-type: none"> ▶ Need help? Product details, page 248 	<ul style="list-style-type: none"> • Table: High-Pressure Laminate price group 1 or wood group 1 veneer • Laminate table: plastic 3 mm edge profile on all sides • Wood table: wood square 3 mm edge profile on all sides 	<ol style="list-style-type: none"> 1 Style number with appropriate edge profile suffix <ul style="list-style-type: none"> SW Composite veneer or wood with square edge ▶ See edge profiles below. 2 High-Pressure Laminate or wood color number for table 3 Plastic color number for edge on laminate table, if selected 4 Options, if selected (see below) ▶ See <i>Surface Materials</i>, page 668.

For composite veneer, wood and laminate group 2 and 3 pricing, please refer to the electronic catalog or SmartTools.

Tip: Bases and legs to support Universal Tables must be specified separately.

Tip: For leg and support guidelines, see Table and Base Combinations, ▶ Page 254 Table and Leg Combinations, ▶ Page 255

Tip: To specify 3 mm edge profile, no suffix is required. For other edge profiles, add suffix to the style number. (For example, BFRQ30 becomes BFRQ30SW for wood square edge profile.)

Options	U.S. Price	Required to Specify
Surface Materials <ul style="list-style-type: none"> • High-Pressure Laminate tables <ul style="list-style-type: none"> • Laminate price group 2 See information at left • Laminate price group 3 See information at left • Open Line laminate +\$102 plus cost of laminate • Composite veneer tables <ul style="list-style-type: none"> • Composite veneer group 1 Prices below • Composite veneer group 2 See information at left • Wood veneer tables <ul style="list-style-type: none"> • Wood group 2 See information at left • Wood group 3 See information at left • Customiz stain No cost • Full-fill finish on wood group 1 Prices below 		Specify laminate color number. Specify laminate color number. ▶ See <i>Surface Materials Reference Manual</i> . Specify composite veneer color number. Specify composite veneer color number. Specify wood color number. Specify wood color number. Specify with <i>Customiz stain</i> . ▶ See <i>Surface Materials Reference Manual</i> . Specify full-fill finish number.
Related Products <ul style="list-style-type: none"> • Worksurface screens • Worksurface power and communication components • Bases for Universal Tables • Legs for Universal Tables 		▶ Page 571 ▶ Page 573 ▶ Page 591 ▶ Page 592

Dimensions		Style Number	U.S. Base Prices			Option (Add \$ to Base Price)
A	B		High-Pressure Laminate Plastic 3 mm Edge No Suffix	Composite Veneer Veneer Square Edge Suffix SW	Wood Square Edge Suffix SW	
24"	24"	BFRQ24	\$ 340	N.A.	N.A.	N.A.
30"	30"	BFRQ30	\$ 500	\$1380	\$1380	+\$56
36"	36"	BFRQ36	\$ 705	N.A.	N.A.	N.A.
42"	42"	BFRQ42	\$ 778	\$1879	\$1879	+\$69
48"	48"	BFRQ48	\$ 855	\$2080	\$2080	+\$77
54"	54"	BFRQ54	\$1026	\$2327	\$2327	+\$81

For Canadian Pricing
 Multiply U.S. Price by the Canadian price factor.
 ▶ See page 1 for details.

Universal Tables

Rectangle Tables

High-Pressure Laminate or Wood Veneer

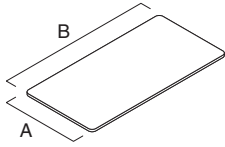

Standard Includes		Required to Specify
<ul style="list-style-type: none"> ▶ Need help? Product details, page 248 	<ul style="list-style-type: none"> • Table: High-Pressure Laminate price group 1 or wood group 1 veneer • Laminate table: plastic 3 mm edge profile on all sides • Wood table: wood square 3 mm edge profile on all sides 	<ol style="list-style-type: none"> 1 Style number with appropriate edge profile suffix <ul style="list-style-type: none"> SW Composite veneer or wood with square edge ▶ See edge profiles below 2 High-Pressure Laminate or wood color number for table 3 Plastic color number for edge on laminate table, if selected 4 Options, if selected (see below) ▶ See <i>Surface Materials</i>, page 668.

For composite veneer, wood and laminate group 2 and 3 pricing, please refer to the electronic catalog or SmartTools.

Tip: Select the reinforcing channel option if the table will be supported by legs. Channels are not required if the table will be supported by T- or X-bases.

Tip: Bases and legs to support Universal Tables must be specified separately.

Tip: For leg and support guidelines, see Table and Base Combinations, ▶ Page 254 Table and Leg Combinations, ▶ Page 255

Tip: To specify 3 mm edge profile, no suffix is required. For other edge profiles, add suffix to the style number. (For example, BFRR3672 becomes BFRR3672SW for wood square edge profile.)

Options	U.S. Price	Required to Specify
Surface Materials <ul style="list-style-type: none"> • High-Pressure Laminate tables <ul style="list-style-type: none"> • Laminate price group 2 • Laminate price group 3 • Open Line laminate • Composite veneer tables <ul style="list-style-type: none"> • Composite veneer group 1 • Composite veneer group 2 • Wood veneer tables <ul style="list-style-type: none"> • Wood group 2 • Wood group 3 • Customiz stain • Full-fill finish on wood group 1 	<ul style="list-style-type: none"> • See information at left • See information at left +\$102 plus cost of laminate • Prices below • See information at left • See information at left • See information at left • See information at left • No cost • No cost • Prices below 	<ul style="list-style-type: none"> • Specify laminate color number. • Specify laminate color number. ▶ See <i>Surface Materials Reference Manual</i>. • Specify composite veneer color number. • Specify composite veneer color number. • Specify wood color number. • Specify wood color number. • Specify with <i>Customiz stain</i>. ▶ See <i>Surface Materials Reference Manual</i>. • Specify full-fill finish number. • Specify with <i>reinforcing channel</i>.
Reinforcing Channel <ul style="list-style-type: none"> • Reinforcing channel (available on 66"W and wider tables) 	<ul style="list-style-type: none"> • No cost 	<ul style="list-style-type: none"> • Specify with <i>reinforcing channel</i>.
Related Products <ul style="list-style-type: none"> • Worksurface screens • Worksurface power and communication components • Bases for Universal Tables • Legs for Universal Tables 		<ul style="list-style-type: none"> ▶ Page 571 ▶ Page 573 ▶ Page 591 ▶ Page 592

Specification Information

Dimensions		Style Number	U.S. Base Prices			Option (Add \$ to Base Price)
A	B		High-Pressure Laminate	Composite Veneer	Wood	
			Plastic 3 mm Edge	Composite Veneer Square Edge	Wood Square Edge	
			No Suffix	Suffix SW	Suffix SW	Full-Fill Finish on Wood Group 1
36"	60"	BFRR3660	\$ 997	N.A.	N.A.	N.A.
36"	66"	BFRR3666	\$1058	N.A.	N.A.	N.A.
36"	72"	BFRR3672	\$1129	\$3315	\$3315	+\$137
42"	84"	BFRR4284	\$1704	\$3571	\$3571	+\$141
48"	96"	BFRR4896	\$2018	\$3668	\$3668	+\$145



For Canadian Pricing
Multiply U.S. Price by the Canadian price factor.
▶ See page 1 for details.

Oval Tables

High-Pressure Laminate

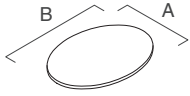

For laminate price group 2 and 3 pricing, please refer to the electronic catalog or SmartTools.

Tip: Bases and legs to support Universal Tables must be specified separately.

Tip: For leg and support guidelines, see Table and Base Combinations, ▶ Page 254 Table and Leg Combinations, ▶ Page 255

Tip: To specify 3 mm edge profile, no suffix is required.

Standard Includes	Required to Specify
-------------------	---------------------

<ul style="list-style-type: none"> ▶ Need help? Product details, page 248 • Tables: High-Pressure Laminate price group 1 • Laminate table: plastic 3 mm edge profile on all sides 	<ol style="list-style-type: none"> 1 Style number 2 High-Pressure Laminate color number for table 3 Plastic color number for edge on laminate table 4 Options, if selected (see below) <p>▶ See <i>Surface Materials</i>, page 668.</p>
--------------------------------------------------------------------------------------------------------------------------------------------------------------------------------------------------------------------	-----------------------------------------------------------------------------------------------------------------------------------------------------------------------------------------------------------------------------------------------------------------------------------

Options	U.S. Price	Required to Specify
---------	------------	---------------------

<p>Surface Materials</p> <p>High-Pressure Laminate tables</p> <ul style="list-style-type: none"> • Laminate price group 2 • Laminate price group 3 • Open Line laminate 	<p>See information at left</p> <p>See information at left +\$102</p> <p>plus cost of laminate</p>	<p>Specify laminate color number.</p> <p>Specify laminate color number.</p> <p>▶ See <i>Surface Materials Reference Manual</i>.</p>
<p>Related Products</p> <ul style="list-style-type: none"> • Bases for Universal Tables • Legs for Universal Tables 		<p>▶ Page 591</p> <p>▶ Page 592</p>

Specification Information		U.S. Base Price
---------------------------	--	-----------------

U.S. Base Price		High-Pressure Laminate	
Dimensions		Plastic 3 mm Edge	
A	B	Style Number	U.S. Price
21"	42"	BEL2142	\$ 752
30"	42"	BEL3042	\$ 820
36"	48"	BEL3648	\$ 900
30"	60"	BEL3060	\$1102
36"	72"	BEL3672	\$1129
42"	78"	BEL4278	\$1681
48"	96"	BEL4896	\$2018
:	:	:	:

Universal Tables

For Canadian Pricing
 Multiply U.S. Price by the Canadian price factor.
 ▶ See page 1 for details.

Hex Conference Tables

High-Pressure Laminate

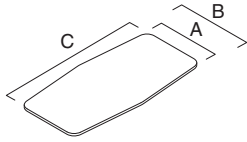

Tip: Hex conference tables 150"W or larger are shipped in two pieces. Tight-joint fasteners are supplied for proper assembly.

For laminate price group 2 and 3 pricing, please refer to the electronic catalog or SmartTools.

Tip: Bases to support Universal Tables must be specified separately.

Tip: For leg and support guidelines, see Table and Base Combinations, Page 254

Tip: To specify 3 mm edge profile, no suffix is required.

Standard Includes	Required to Specify
-------------------	---------------------

<ul style="list-style-type: none"> ▶ Need help? Product details, page 248 • Tables: High-Pressure Laminate price group 1 • Laminate table: plastic 3 mm edge profile on all sides • Reinforcing channels, for tables 120"W or wider • Tight-joint fasteners for tables 150"W or wider 	<ol style="list-style-type: none"> 1 Style number 2 High-Pressure Laminate color number for table 3 Plastic color number for edge on laminate table 4 Options, if selected (see below) <p>▶ See <i>Surface Materials</i>, page 668.</p>
------------------------------------------------------------------------------------------------------------------------------------------------------------------------------------------------------------------------------------------------------------------------------------------------------------------------------------------	-----------------------------------------------------------------------------------------------------------------------------------------------------------------------------------------------------------------------------------------------------------------------------------

Options	U.S. Price	Required to Specify
---------	------------	---------------------

Surface Materials High-Pressure Laminate tables <ul style="list-style-type: none"> • Laminate price group 2 • Laminate price group 3 • Open Line laminate 	See information at left See information at left +\$102 plus cost of laminate	Specify laminate color number. Specify laminate color number. ▶ See <i>Surface Materials Reference Manual</i> .
-------------------------------------------------------------------------------------------------------------------------------------------------------------------------------------------------------------	---------------------------------------------------------------------------------------	-----------------------------------------------------------------------------------------------------------------------

Related Products <ul style="list-style-type: none"> • Bases for Universal Tables 	▶ Page 591
--------------------------------------------------------------------------------------------------------	------------

Specification Information

Dimensions			Style Number	U.S. Base Price High-Pressure Laminate	Plastic 3 mm Edge
A	B	C			
30"	36"	60"	BHEX3660	\$ 997	
30"	36"	66"	BHEX3666	\$1058	
30"	36"	72"	BHEX3672	\$1129	
36"	42"	96"	BHEX4296	\$1930	
38"	48"	120"	BHEX48120	\$4663	
38"	48"	150"	BHEX48150	\$6810	
38"	48"	180"	BHEX48180	\$7082	
⋮	⋮	⋮	⋮	⋮	⋮



For Canadian Pricing
 Multiply U.S. Price by the Canadian price factor.
 ▶ See page 1 for details.

Bases for Universal Tables

Standard Includes		Required to Specify
▶ Need help? Product details, page 251	<ul style="list-style-type: none"> • Column: paint • Base: paint • Adjustable leveling glides: black plastic 	1 Style number 2 Paint color number for column 3 Paint color number for base 4 Options, if selected (see below) ▶ See <i>Surface Materials</i> , page 668.

Options	U.S. Price	Required to Specify
Surface Materials		
Base		
• Paint price group 1	No cost	Specify paint color number
• Paint price group 2	+\$ 28	Specify paint color number.
• Paint price group 3	+\$ 51	Specify paint color number.
• Polished Aluminum column and base	+\$237	Specify with <i>8046 Polished Aluminum column and base</i> .
• Polished Aluminum base with painted column	+\$237	Specify with <i>8046 Polished Aluminum base only</i> and select paint color number for column.

Tip: When specifying a 8046 Polished Aluminum base only, specify a paint color number for the column.

Specification Information			
Width	Column Diameter	Style Number	U.S. Base Price

T-Bases			
26"	2 1/4"	BT26	\$471
36"	2 1/4"	BT36	\$582

X-Bases			
26"	2 1/4"	BX26	\$531
36"	2 1/4"	BX36	\$685

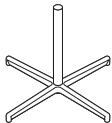
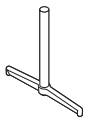

 **For Canadian Pricing**
 Multiply U.S. Price by the Canadian price factor.
 ▶ See page 1 for details.

Legs for Universal Tables

Adjustable-Height Legs

Tip: Corner tables require a leg in the back corner. Be sure to order fifth leg if specifying a package of four.

Tip: See Table and Leg Combinations page for number of legs required per table.
▶ Page 255

Tip: Dimensions listed are nominal and include the thickness of a table.



Standard Includes		Required to Specify
▶ Need help? Product details, page 252	<ul style="list-style-type: none"> Table legs: paint Glides, if selected: paint to match legs Locking casters, if selected: paint to match legs Attachment hardware 	1 Style number 2 Paint color number for leg 3 Options, if selected (see below) ▶ See <i>Surface Materials</i> , page 668.

Options	U.S. Price	Required to Specify
Surface Materials <ul style="list-style-type: none"> Paint price group 1 Paint price group 2 	No cost +\$29 per leg	Specify paint color number. Specify paint color number.

Specification Information					
Planning Height	Style Number	U.S. Base Price	Planning Height	Style Number	U.S. Base Price

Adjustable-Height Leg with Glide			Package of Four Adjustable-Height Legs with Glides		
25½"-31½"	BADJ	\$328	25½"-31½"	BADJ4	\$1312

Adjustable-Height Leg with Caster			Package of Four Adjustable-Height Legs with Casters		
25½"-31½"	BADJC	\$365	25½"-31½"	BADJ4C	\$1460



For Canadian Pricing
Multiply U.S. Price by the Canadian price factor.
▶ See page 1 for details.

Post Legs

With Alignment Tab

Tip: See Table and Leg Combinations page for number of legs required per worksurface.
 ▶ Page 255

Tip: Corner tables require a leg in the back corner. Be sure to order fifth leg if specifying a package of four.

Tip: Height dimensions listed are nominal and include the thickness of a table.



Standard Includes		Required to Specify
▶ Need help? Product details, page 252	<ul style="list-style-type: none"> Table legs: paint Attachment hardware Non-locking caster, if selected: black plastic only 	1 Style number 2 Paint color number for legs. 3 Options, if selected (see below) ▶ See <i>Surface Materials</i> , page 668.

Options	U.S. Price	Required to Specify
Surface Materials	<ul style="list-style-type: none"> Paint price group 1 Paint price group 2 Paint price group 3 	No cost +\$29 per leg +\$51 per leg Specify paint color number. Specify paint color number. Specify paint color number.

Specification Information

Planning Height	Style Number	U.S. Base Price	Planning Height	Style Number	U.S. Base Price
-----------------	--------------	-----------------	-----------------	--------------	-----------------

Post Leg with Glide			Package of Four Post Legs with Glides		
28½"	BPL	\$214	28½"	BPL4	\$856

Post Leg with Caster			Package of Four Post Legs with Casters		
28½"	BPLC	\$240	28½"	BPL4C	\$960

 **For Canadian Pricing**
 Multiply U.S. Price by the Canadian price factor.
 ▶ See page 1 for details.



Specifying Answer Monitor Mount Integration

Answer Monitor Mount

596

**Answer Monitor
Mount Integration**

Answer Monitor Mount

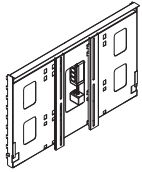

Tip: Use of a 40" or 42" monitor is recommended.

Standard Includes		Required to Specify
<ul style="list-style-type: none"> ▶ Need help? Product details, page 260 	<ul style="list-style-type: none"> • Monitor mount • Mounting brackets • Hardware package • Power strip 	<ul style="list-style-type: none"> • Style number

Specification Information			
Dimensions		Style	U.S.
D	W	Number	Price
21"	40"	TS7MTRMNT	\$4092
:	:	:	:

 **For Canadian Pricing**
 Multiply U.S. Price by the Canadian price factor.
 ▶ See page 1 for details.

Specifying Universal Steel Storage Products

Universal Pedestals

Universal Fixed Pedestals	598
Universal Pedestal Fillers and Counterweights	600
Universal Fixed to Freestanding Pedestal Conversion Kits	601
Universal Mobile Pedestals	602
Basic Cushions Enhanced	605

Universal Bins and Shelves

Universal Sliding Door Bins with Steel, Laminate, or Wood Front	606
Universal Over the Case Bins with Flat Fronts	608
Universal In the Case Bins with Steel, Laminate, or Wood Flat Fronts	610
Universal Shelves	613
Accessories for Overhead Bins and Shelves	614

Slim Shelves

619

Universal One-High, 1.5-High, and Two Drawer Lateral Files

620

Low Storage-to-Beam Tether Bracket

625

Cushion Tops

626

Basic Cushions Enhanced

627

Universal Towers

Universal Open Side Towers	628
Universal Dual Door Towers	632

Universal Fixed Pedestals

with Flush Steel, Proud Steel, Proud Laminate, or Proud Wood Fronts

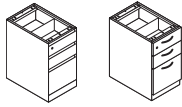

► Need help?
Product details,
page 278

Standard Includes

- Pedestal: paint price group 1
- Removable drawer fronts: paint to match pedestal, laminate price group 1 if proud laminate front selected, or wood group 1 veneer if proud wood front selected
- Integral pulls on units with flush steel fronts
- Pulls: metal
 - One pencil tray and two box drawer dividers per box/file
- Full drawer interiors: black only
- Lock, keyed random: 9201 Polished Chrome
- Mounting hardware
- Four adjustable leveling glides

Required to Specify

- 1 Style number with appropriate front style suffix in the space provided
 - F** Flush steel front
 - P** Proud steel front
 - L** Proud laminate front
 - W** Proud composite veneer or wood front
- 2 Paint color number for pedestal
- 3 Laminate color number for drawer fronts, if proud laminate front selected
- 4 Wood color number for drawer fronts, if proud wood front selected
- 5 Pull (see below under Required Selections)
- 6 Metal color number for pulls, if proud steel or proud wood front selected
- 7 Options, if selected (see below)
 - See *Surface Materials*, page 668.

Required Selections

Pulls

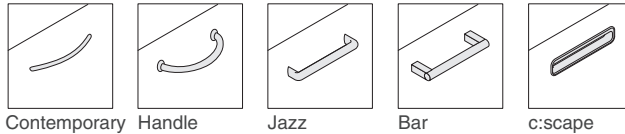

Contemporary

Handle

Jazz

Bar

c:scape

For composite veneer, wood group 2, wood group 3, laminate price group 2, and laminate price group 3 pricing, please refer to the electronic catalog or SmartTools.

Options

U.S. Price

Required to Specify

Surface Materials

- Paint price group 1 No cost
- Paint price group 2 +\$ 65
- Paint price group 3 +\$111
- Laminate price group 1 on proud laminate drawer fronts Prices at right
- Laminate price group 2 on proud laminate drawer fronts See information at left
- Laminate price group 3 on proud laminate drawer fronts See information at left
- Open Line laminate on proud laminate drawer fronts +\$102 plus cost of laminate
- Composite veneer group 1 on proud wood drawer fronts Prices at right
- Composite veneer group 2 on proud wood drawer fronts See information at left
- Wood group 2 on proud wood drawer fronts See information at left
- Wood group 3 on proud wood drawer fronts See information at left
- Customiz stain on proud wood drawer fronts No cost

- Specify paint color number.
- Specify paint color number.
- Specify paint color number.
- Specify laminate color number.
- Specify laminate color number.
- Specify laminate color number.
- See *Surface Materials Reference Manual*.
- Specify composite veneer color number.
- Specify composite veneer color number.
- Specify wood color number.
- Specify wood color number.
- Specify *with Customiz stain*.
- See *Surface Materials Reference Manual*.

Pulls

Flush steel fronts

- Full-width wood veneer pull +\$390
- Customiz stain on wood veneer pull No cost

- Specify *with wood pull* and indicate wood color number.
- Specify *with Customiz stain*.
- See *Surface Materials Reference Manual*.

Proud steel, laminate, or wood fronts

- Contemporary No cost
- Handle No cost
- Jazz +\$ 28 per pull
- Bar +\$ 43 per pull

- Specify *with contemporary pull*.
- Specify *with handle pull*.
- Specify *with jazz pull*.
- Specify *with bar pull*.

Proud steel fronts only

- c:scape +\$ 48 per pull

- Specify *with c:scape pull*.

► Options, continued on next page



For Canadian Pricing

Multiply U.S. Price by the Canadian price factor.

► See page 1 for details.

► Options, continued from previous page

Tip: Counterweight packages are required to ensure product stability and are ordered as an option or separately. Product specification pages indicate the correct counterweight package for each style number and any exceptions where counterweights are not required.

► See Counterweight Requirements for Storage Products, pages 265–272.

Options	U.S. Price	Required to Specify
Drawer Accessories • Two side-to-side hanging rails per file drawer	No cost	Specify with rails.
Basic Drawer Interiors • No rails, pencil trays, or box drawer dividers	–\$ 80	Specify with basic drawers.
Lock and Keying • Ember Chrome • No lock	No cost –\$101	Specify with 9250 Ember Chrome lock. Specify with no lock.
Individual locking drawers • File/file pedestals only	+\$191	Specify with individual drawer lock.
Keying • Factory- and field-installed keying		► Page 686
Related Products • Universal fixed to freestanding pedestal conversion kits • Steel storage accessories		► Page 601 ► Page 655

Specification Information

Tip: Your specification is not complete until you add a suffix to the style number to define the front style (for example, RPF1827A__ becomes RPF1827AP for proud steel front).

Dimensions		W	H	Counterweight Package	Style Number	U.S. Base Prices				
D	Front					Flush Steel Front	Proud Steel/Lam/Comp Ven/Wood Front	Proud Lam Front	Proud Comp Ven Front	Proud Wood Front
						Suffix F	Suffix P	Suffix L	Suffix W	Suffix W

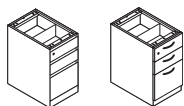

Tip: Use 27"H pedestals to align with Universal Storage with 3" base. 27"H pedestals support worksurfaces at 28½"H.

Tip: Only 22⅝"D, 23½"D, 28⅝"D, and 29½"D pedestals can accommodate legal-size filing.

27"H Fixed Pedestals with 3" Base

Two Box Drawers and One File Drawer

17½"	18⅜"	15"	27"	RPCW	RPF1827A__	\$ 908	\$1007	\$1277	\$1385	\$1385
22⅝"	23½"	15"	27"	RPCW	RPF2427A__	\$ 991	\$1090	\$1360	\$1468	\$1468
28⅝"	29½"	15"	27"	RPCW	RPF3027A__	\$1191	\$1290	\$1560	\$1668	\$1668

Two File Drawers

17½"	18⅜"	15"	27"	RPCW	RPF1827B__	\$ 879	\$ 978	\$1248	\$1356	\$1356
22⅝"	23½"	15"	27"	RPCW	RPF2427B__	\$ 962	\$1061	\$1331	\$1439	\$1439
28⅝"	29½"	15"	27"	RPCW	RPF3027B__	\$1162	\$1261	\$1531	\$1639	\$1639



For Canadian Pricing

Multiply U.S. Price by the Canadian price factor.

► See page 1 for details.

Universal Pedestal Fillers and Counterweights

Universal Pedestal Fillers for 27"H Fixed Pedestals with Flush and Proud Fronts

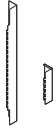

Standard Includes	Required to Specify
<ul style="list-style-type: none"> ▶ Need help? Product details, page 279 • Filler: all paint price groups • Installation hardware 	<ul style="list-style-type: none"> 1 Style number 2 Paint color number for filler ▶ See <i>Surface Materials</i>, page 668.

Specification Information						
Dimensions		H	On- or Off-Module	Application	Style Number	U.S. Price
D	Front					
Flush Steel Front	Proud Steel/Wood Front					

Pedestal Fillers for 27"H Fixed Pedestals with Flush Steel Fronts

13/8"	N.A.	27"	On-Module	Answer and Kick Panels	RPXFTAKFP	\$107
-------	------	-----	-----------	------------------------	------------------	-------

Pedestal Fillers for 27"H Fixed Pedestals with Proud Fronts

N.A.	1/2"	27"	On-Module	Answer and Kick Panels	RPXFTAKPP	\$107
------	------	-----	-----------	------------------------	------------------	-------

Universal Pedestal Counterweight

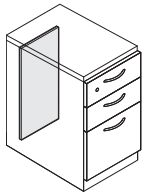

Tip: Counterweights fit 27"H fixed pedestals only.

Standard Includes	Required to Specify
<ul style="list-style-type: none"> ▶ Need help? Product details, page 279 • Pedestal counterweight: black 	<ul style="list-style-type: none"> Style number

Specification Information	
Style Number	U.S. Price
RPCW	\$221



For Canadian Pricing
 Multiply U.S. Price by the Canadian price factor.
 ▶ See page 1 for details.

Universal Fixed to Freestanding Pedestal Conversion Kits

Universal Fixed to Freestanding Pedestal Conversion Kits

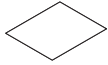

Tip: Flush and proud front pedestals require different conversion kits. Be sure to order the correct style number for your application.

Tip: When converting a file/file pedestal with individual drawer locks, an interlocking bar is required to provide stability to unit. Order 1043922SR through Service Parts.

Standard Includes	Required to Specify
<ul style="list-style-type: none"> ▶ Need help? Product details, page 279 • 1/8"H steel top: all paint price groups • Counterweight package • Installation hardware 	<ul style="list-style-type: none"> 1 Style number 2 Paint color number for top ▶ See <i>Surface Materials</i>, page 668.

Specification Information

• Dimensions		• Style	• U.S.
D	H	Number	Price

For 27"H Proud Steel or Proud Wood Front Pedestals

18 ³ / ₈ "	27"	RPXCK2718P	\$307
23 ¹ / ₂ "	27"	RPXCK2724P	\$338
29 ¹ / ₂ "	27"	RPXCK2730P	\$374

For 27"H Flush Steel Front Pedestals

17 ¹ / ₂ "	27"	RPXCK2718F	\$307
22 ⁵ / ₈ "	27"	RPXCK2724F	\$338
28 ⁵ / ₈ "	27"	RPXCK2730F	\$374

 **For Canadian Pricing**
 Multiply U.S. Price by the Canadian price factor.
 ▶ See page 1 for details.

Universal Mobile Pedestals

With Flush Steel, Proud Steel, Proud Laminate, or Proud Wood Fronts

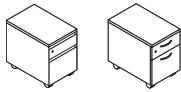

Tip: 1/8"H steel top is non-structural.

Tip: Counterweight packages for mobile pedestals are required to ensure product stability and are included.

▶ See Counterweight Requirements for Storage Products, pages 265–272.

Standard Includes	Required to Specify
<p>▶ Need help? Product details, page 278</p> <ul style="list-style-type: none"> • Pedestal: paint price group 1 • 1/8"H steel top: paint to match pedestal • Removable drawer fronts: paint to match pedestal, laminate price group 1 if proud laminate selected, or wood group 1 veneer if proud wood front selected • Integral pulls on units with flush steel fronts • Pulls: metal • Full drawer interiors: black only <ul style="list-style-type: none"> – One pencil tray per box/file or box/box/file and box drawer dividers • Lock, keyed random: 9201 Polished Chrome • Four hard-composition, non-locking casters: black only • Safety interlock mechanism • Counterweight package 	<ol style="list-style-type: none"> 1 Style number with appropriate front style suffix in the space provided <ul style="list-style-type: none"> F Flush steel front P Proud steel front L Proud laminate front W Proud composite veneer or wood front 2 Paint color number for pedestal 3 Laminate color number for drawer fronts, if proud laminate front selected 4 Wood color number for drawer fronts, if proud wood front selected 5 Pull (see below under required selections) 6 Metal color number for pulls, if proud steel, proud laminate, or proud wood front selected 7 Options, if selected (see below) <p>▶ See <i>Surface Materials</i>, page 668.</p>

Required Selections

Pulls

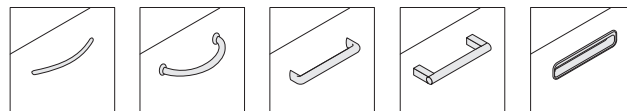

Contemporary Handle Jazz Bar c:scape

Options	U.S. Price	Required to Specify
<p>Surface Materials</p> <ul style="list-style-type: none"> • Paint price group 1 • Paint price group 2 • Paint price group 3 • Laminate price group 1 on proud laminate drawer fronts • Laminate price group 2 on proud laminate drawer fronts • Laminate price group 3 on proud laminate drawer fronts • Open Line laminate on proud laminate drawer fronts • Composite veneer group 1 on proud wood drawer fronts • Composite veneer group 2 on proud wood drawer fronts • Wood group 2 on proud wood drawer fronts • Wood group 3 on proud wood drawer fronts • Customiz stain on proud wood drawer fronts 	<p>No cost</p> <p>+\$ 65</p> <p>+\$111</p> <p>Prices at right</p> <p>+\$ 14</p> <p>+\$ 34</p> <p>+\$102 plus cost of laminate</p> <p>+\$ 41</p> <p>+\$138</p> <p>+\$ 41</p> <p>See information at left</p> <p>No cost</p>	<p>Specify paint color number.</p> <p>Specify paint color number.</p> <p>Specify paint color number.</p> <p>Specify laminate color number.</p> <p>Specify laminate color number.</p> <p>▶ See <i>Surface Materials Reference Manual</i>.</p> <p>Specify composite veneer color number.</p> <p>Specify composite veneer color number.</p> <p>Specify wood color number.</p> <p>Specify wood color number.</p> <p>Specify with <i>Customiz stain</i>.</p> <p>▶ See <i>Surface Materials Reference Manual</i>.</p>
<p>Tops</p> <ul style="list-style-type: none"> • 1"H square edge steel top • Laminate top • 1 3/16"H square edge laminate price group 1 top • 1 3/16"H square edge laminate price group 2 top 	<p>+\$105</p> <p>+\$440</p> <p>+\$447</p>	<p>Specify with <i>steel square top</i>.</p> <p>Specify with <i>laminate top</i> and indicate laminate color number for top and plastic color number for edges.</p> <p>Specify with <i>laminate top</i> and indicate laminate color number for top and plastic color number for edges.</p>

Tip: Composite veneer, laminate and wood price group 2 and 3 upcharges for drawer fronts are in addition to laminate and wood price group 1.

Tip: Optional tops will increase the overall pedestal height.

For Canadian Pricing
Multiply U.S. Price by the Canadian price factor.
▶ See page 1 for details.

▶ Options, continued on next page

► Options, continued from previous page

	Options	U.S. Price	Required to Specify
Tops continued	Laminate top, continued		
	• 1 ³ / ₁₆ "H square edge laminate price group 3 top	+\$ 458	Specify with <i>laminate top</i> and indicate laminate color number for top and plastic color number for edges. ► See <i>Surface Materials Reference Manual</i> .
	• Open Line laminate on laminate top	+\$ 102 plus cost of laminate	► See <i>Surface Materials Reference Manual</i> .
	Composite veneer top		
	• 1 ³ / ₁₆ "H composite veneer group 1 veneer top	+\$ 595	Specify with <i>composite veneer top</i> and indicate composite veneer color number.
	• 1 ³ / ₁₆ "H composite veneer group 2 veneer top	+\$ 637	Specify with <i>composite veneer top</i> and indicate composite veneer color number.
	Wood veneer top		
	• 1 ³ / ₁₆ "H wood price group 1 veneer top	+\$ 595	Specify with <i>wood veneer top</i> and indicate wood color number.
	• 1 ³ / ₁₆ "H wood group 2 veneer top	See information at left	Specify with <i>wood veneer top</i> and indicate wood color number.
	• 1 ³ / ₁₆ "H wood group 3 veneer top	See information at left	Specify with <i>wood veneer top</i> and indicate wood color number.
• Customiz stain on wood veneer top	No cost	Specify with <i>Customiz stain</i> . ► See <i>Surface Materials Reference Manual</i> .	
	Cushion top for factory installation on RPM2421C__ only		
	• Cushion top without handle	+\$ 544	Specify with <i>cushion top</i> and indicate fabric color number.
	• Cushion top with black handle	+\$ 685	Specify with <i>cushion top and handle</i> and indicate fabric color number.
	Upholstery on pedestal cushion top		
	• Fabric price group 1	No cost	Specify fabric color number.
	• Fabric price group 2	+\$ 12	Specify fabric color number.
	• Fabric price group 3	+\$ 59	Specify fabric color number.
	• Fabric price group 4	+\$ 73	Specify fabric color number.
	• Fabric price group 5	+\$ 92	Specify fabric color number.
	• Fabric price group 6	+\$ 129	Specify fabric color number.
	• Fabric price group 7	+\$ 154	Specify fabric color number.
	• Fabric price group 8	+\$ 223	Specify fabric color number.
	• Fabric price group 9	+\$ 286	Specify fabric color number.
	• Fabric price group 10	+\$ 348	Specify fabric color number.
	• Leather price group	+\$ 894	Specify leather color number.
	• Elmosoft leather price group	+\$1030	Specify Elmosoft leather color number. ► See <i>Surface Materials</i> , page 668. ► See <i>Surface Materials Reference Manual</i> to specify.
	• Customer's Own Material (COM) or Customer's Own Leather (COL)	+\$ 23	► See <i>Surface Materials Reference Manual</i> to specify.
Pulls	Flush steel fronts		
	• Full-width wood veneer pull	+\$ 390	Specify with <i>wood pull</i> and indicate wood color number.
	• Customiz stain on wood veneer pull	No cost	Specify with <i>Customiz stain</i> . ► See <i>Surface Materials Reference Manual</i> .
	Proud steel, laminate, or wood fronts		
	• Contemporary	No cost	Specify with <i>contemporary pull</i> .
	• Handle	No cost	Specify with <i>handle pull</i> .
	• Jazz	+\$ 28 per pull	Specify with <i>jazz pull</i> .
	• Bar	+\$ 43 per pull	Specify with <i>bar pull</i> .
	Proud steel fronts only		
	• c:scape	+\$ 48 per pull	Specify with <i>c:scape pull</i> .
Drawer Accessories	Rails		
	• Two side-to-side hanging rails per file drawer	No cost	Specify with <i>rails</i> .

► Options, continued on next page

Tip: If wood veneer top option is selected, finishes must be selected for both the wood veneer top and the wood veneer fronts.

For laminate and wood price group 2 and 3 pricing, please refer to the online catalog or SmartTools.

Tip: For both cushion top and basic cushion enhanced: fabric patterns with a linear design will always be applied from the front to back of the unit (depth of the unit).

Tip: For both cushion top and basic cushion enhanced: pattern matching will not be done on COM.



For Canadian Pricing
Multiply U.S. Price by the Canadian price factor.
► See page 1 for details.

Universal Mobile Pedestals with Flush Steel, Proud Steel, Proud Laminate, or Proud Wood Fronts, continued

► Options, continued from previous page

Options	U.S. Price	Required to Specify
Basic Drawer Interiors	Box/file and box/box/file pedestals • No rails, pencil trays, or box drawer dividers -\$ 80	Specify with basic drawers.
Lock and Keying	Lock • Ember Chrome No cost	Specify with 9250 Ember Chrome lock.
	Individual locking drawers • File/file pedestals only +\$194	Specify with individual drawer lock.
	Keying • Factory- and field-installed keying	► Page 686
Related Products	• Steel storage accessories	► Page 655

Tip: Your specification is not complete until you add a suffix to the style number to define the front style (for example, RPM1821C__ becomes RPM1821CP for proud steel front).

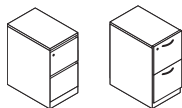
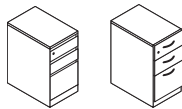
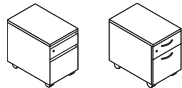

Specification Information										
Dimensions D	W	H	Counter-weight Package	Style Number	U.S. Base Prices					
					Flush Steel Front	Proud Steel Front	Proud Lam Front	Proud Comp Ven Front	Proud Wood Front	
					Suffix F	Suffix P	Suffix L	Suffix W	Suffix W	

Box/File

17½"	18¾"	15"	21"	Included	RPM1821C__	\$1246	\$1345	\$1615	\$1723	\$1723
22½"	23½"	15"	21"	Included	RPM2421C__	\$1358	\$1457	\$1727	\$1835	\$1835

Box/Box/File

17½"	18¾"	15"	27"	Included	RPM1827A__	\$1424	\$1477	\$1753	\$1861	\$1861
22½"	23½"	15"	27"	Included	RPM2427A__	\$1518	\$1566	\$1842	\$1950	\$1950

File/File

17½"	18¾"	15"	27"	Included	RPM1827B__	\$1353	\$1448	\$1724	\$1832	\$1832
22½"	23½"	15"	27"	Included	RPM2427B__	\$1492	\$1537	\$1813	\$1921	\$1921

Specification Information										
Actual Dimensions D W H			Style Number	U.S. Base Price						

Pedestal Cushion Top for Field Installation on RPM2421C__ only

Cushion Top without Handle

22½"	15"	2¼"	RPXTC24F	\$483	(For use with RPM2421CF only)
23½"	15"	2¼"	RPXTC24P	\$483	(For use with RPM2421CP, RPM2421CL, and RPM2421CW only)

Cushion Top with Black Handle

22½"	15"	2¼"	RPXTCH24F	\$649	(For use with RPM2421CF only)
23½"	15"	2¼"	RPXTCH24P	\$649	(For use with RPM2421CP, RPM2421CL, and RPM2421CW only)

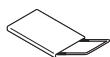

Tip: If used with a Universal mobile pedestal manufactured before 12/20/2011, you will need to order service part 1072962001SR for attachment hardware.

Basic Cushions Enhanced

For Universal Mobile Pedestals

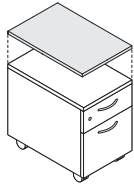

Tip: Basic cushion enhanced is field-installed and supplies to attach are included.

Tip: Basic cushion enhanced is available on Universal mobile pedestals RPM1821CF, RPM1821CP, RPM1821CL, RPM1821CW, RPM2421CF, RPM2421CP, PRM2421CL, and RPM2421CW with a top only.

Tip: Basic cushion enhanced is constructed with a thin solid base.

Tip: For both cushion top and basic cushion enhanced: Fabric patterns with a linear design will always be applied from the front to back of the unit (depth of the unit).

Tip: For both cushion top and basic cushion enhanced: Pattern matching will not be done on COM.

Standard Includes	Required to Specify
-------------------	---------------------

- | | | |
|------------------------------------------------------------------------------------------|-------------------------------------------------------------------------------------------------------------------------------------------------------|----------------------------------------------------------------------------------------------------------------------------------------------------------------------------------------------------------------|
| <ul style="list-style-type: none"> ▶ Need help? Product details, page 278 | <ul style="list-style-type: none"> • Enhanced cushion top: fabric price group 1 • Attachment supplies: hook and loop fastener | <ul style="list-style-type: none"> 1 Style number 2 Fabric color number for cushion top 3 Options, if selected (see below) ▶ See <i>Surface Materials</i>, page 668. |
|------------------------------------------------------------------------------------------|-------------------------------------------------------------------------------------------------------------------------------------------------------|----------------------------------------------------------------------------------------------------------------------------------------------------------------------------------------------------------------|

Options	U.S. Price	Required to Specify
---------	------------	---------------------

Surface Materials	Upholstery	U.S. Price	Required to Specify
	• Fabric price group 1	No cost	Specify fabric color number.
	• Fabric price group 2	+\$ 12	Specify fabric color number.
	• Fabric price group 3	+\$ 59	Specify fabric color number.
	• Fabric price group 4	+\$ 73	Specify fabric color number.
	• Fabric price group 5	+\$ 92	Specify fabric color number.
	• Fabric price group 6	+\$129	Specify fabric color number.
	• Fabric price group 7	+\$154	Specify fabric color number.
	• Fabric price group 8	+\$223	Specify fabric color number.
	• Fabric price group 9	+\$286	Specify fabric color number.
	• Fabric price group 10	+\$348	Specify fabric color number.
	• Customer's Own Material (COM)	+\$ 23	Specify fabric color number.
			▶ See <i>Surface Materials Reference Manual</i> .

Related Products	U.S. Price	Required to Specify
------------------	------------	---------------------

- | | | |
|--------------------------------------------------------------------------------|--|--------------------------------------------------------------|
| <ul style="list-style-type: none"> • Universal mobile pedestals | | <ul style="list-style-type: none"> ▶ Page 602 |
|--------------------------------------------------------------------------------|--|--------------------------------------------------------------|

Specification Information

Dimensions			Style Number	U.S. Base Price
D	W	H		
17½"	15"	1"	RCHE1715	\$275
22⅝"	15"	1"	RCHE2315	\$289

For Canadian Pricing
 Multiply U.S. Price by the Canadian price factor.
 ▶ See page 1 for details.

Universal Sliding Door Bins with Steel, Laminate, or Wood Front

For Use with Answer

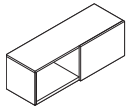

Standard Includes	Required to Specify
<ul style="list-style-type: none"> ▶ Need help? Product details, page 282 • Overhead bin: paint price group 1 • Sliding door: paint price group 1, laminate price group 1, or wood group 1 • Recess beneath unit to accommodate shelf light • Shelf backstop • On-module attachment brackets with safety catch: black paint only • Vertical off-module attachment brackets, if selected: black paint only • Lock, keyed random: 9201 Polished Chrome 	<ul style="list-style-type: none"> 1 Style number 2 Paint color number for overhead bin 3 Paint, laminate, or wood color number for door 4 Options, if selected (see below) ▶ See <i>Surface Materials</i>, page 668.

Options	U.S. Price	Required to Specify	
Surface Materials	Overhead bin with one steel door		
<ul style="list-style-type: none"> • Paint price group 1 • Paint price group 2 • Paint price group 3 	<ul style="list-style-type: none"> No cost +\$ 65 +\$111 	<ul style="list-style-type: none"> Specify paint color number. Specify paint color number. Specify paint color number. 	
	Overhead bin with one laminate or wood door		
<ul style="list-style-type: none"> • Paint price group 1 • Paint price group 2 • Paint price group 3 • Laminate price group 1 on laminate door • Laminate price group 2 on laminate door • Laminate price group 3 on laminate door • Open Line laminate on laminate door • Composite veneer group 1 on wood door • Composite veneer group 2 on wood door • Wood group 2 on wood door • Wood group 3 on wood door • Customiz stain on wood door 	<ul style="list-style-type: none"> No cost +\$ 65 +\$101 Prices at right See information at left See information at left See information at left +\$102 plus cost of laminate See information at left See information at left See information at left See information at left See information at left No cost 	<ul style="list-style-type: none"> Specify paint color number. Specify paint color number. Specify paint color number. Specify laminate color number. Specify laminate color number. Specify laminate color number. ▶ See <i>Surface Materials Reference Manual</i>. Specify composite veneer color number. Specify composite veneer color number. Specify wood color number. Specify wood color number. Specify with <i>Customiz stain</i>. ▶ See <i>Surface Materials Reference Manual</i>. 	
	Brackets		
	Off-module attachment brackets		
<ul style="list-style-type: none"> • One vertical off-module bracket • Two vertical off-module brackets 	<ul style="list-style-type: none"> +\$ 98 +\$196 	<ul style="list-style-type: none"> Specify with one vertical off-module bracket. Specify with two vertical off-module brackets. 	
	Upmount brackets		
<ul style="list-style-type: none"> • Upmount kit 	<ul style="list-style-type: none"> +\$288 	<ul style="list-style-type: none"> Specify with upmount kit. 	
	No brackets		
<ul style="list-style-type: none"> • Omit brackets 	<ul style="list-style-type: none"> -\$ 31 	<ul style="list-style-type: none"> Specify omit brackets. 	
Shelf Accessories	<ul style="list-style-type: none"> • Four dividers: white plastic 	<ul style="list-style-type: none"> +\$ 76 	<ul style="list-style-type: none"> Specify with dividers.
Lock and Keying	Lock		
	<ul style="list-style-type: none"> • No lock • Ember Chrome 	<ul style="list-style-type: none"> -\$104 No cost 	<ul style="list-style-type: none"> Specify with no lock. Specify with 9250 Ember Chrome lock.
	Keying		
	<ul style="list-style-type: none"> • Factory- and field-installed keying 		<ul style="list-style-type: none"> ▶ Page 686
Related Products	<ul style="list-style-type: none"> • Accessories 		<ul style="list-style-type: none"> ▶ Page 614

For composite veneer, wood group 2, wood group 3, laminate price group 2, and laminate price group 3 pricing, please refer to the electronic catalog or *SmartTools*.

Tip: Upmount brackets include steel back to enclose storage bin.



For Canadian Pricing
 Multiply U.S. Price by the Canadian price factor.
 ▶ See page 1 for details.

Specification Information

Dimensions			Style	U.S.	Style	U.S.
D	W	H	Number	Base Price	Number	Base Price

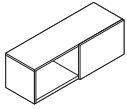

Tip: Overhead storage bins with a "TAK" suffix can be used with Privacy Wall as well.

▶ See Architectural Solutions Specification Guide for attachment information.

Steel Fronts

15¾"	36"	16¼"	RSB36TAK	\$1050
15¾"	42"	16¼"	RSB42TAK	\$1088
15¾"	48"	16¼"	RSB48TAK	\$1119
15¾"	60"	16¼"	RSB60TAK	\$1693
15¾"	66"	16¼"	RSB66TAK	\$1784
15¾"	72"	16¼"	RSB72TAK	\$1852

Laminate Fronts

RSB36LTAK	\$1602
RSB42LTAK	\$1640
RSB48LTAK	\$1671
RSB60LTAK	\$2692
RSB66LTAK	\$2783
RSB72LTAK	\$2851

Composite Veneer Fronts

15¾"	36"	16¼"	RSB36WTAK	\$1646
15¾"	42"	16¼"	RSB42WTAK	\$1684
15¾"	48"	16¼"	RSB48WTAK	\$1715
15¾"	60"	16¼"	RSB60WTAK	\$2736
15¾"	66"	16¼"	RSB66WTAK	\$2827
15¾"	72"	16¼"	RSB72WTAK	\$2895

Wood Fronts

RSB36WTAK	\$1646
RSB42WTAK	\$1684
RSB48WTAK	\$1715
RSB60WTAK	\$2736
RSB66WTAK	\$2827
RSB72WTAK	\$2895



For Canadian Pricing

Multiply U.S. Price by the Canadian price factor.

▶ See page 1 for details.

Universal Over the Case Bins with Flat Fronts

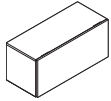

Standard Includes	Required to Specify
<ul style="list-style-type: none"> ▶ Need help? Product details, page 286 • Overhead bin with lift-up door: paint price group 1 • Recess beneath unit to accommodate shelf light • Shelf backstop • On-module attachment brackets with safety catch: black paint only • Off-module attachment brackets, if selected: black paint only • Picture frame door glass insert, if selected: 6580 Ice White only • Lock, keyed random: 9201 Polished Chrome 	<ul style="list-style-type: none"> 1 Style number 2 Paint color number for overhead bin 3 Options, if selected (see below) ▶ See <i>Surface Materials</i>, page 668.

Options	U.S. Price	Required to Specify
Surface Materials <ul style="list-style-type: none"> • Overhead bin with one door • Paint price group 1 No cost • Paint price group 2 +\$ 65 • Paint price group 3 +\$111 <hr/> <ul style="list-style-type: none"> • Overhead bin with two doors • Paint price group 1 No cost • Paint price group 2 +\$ 88 • Paint price group 3 +\$155 		<ul style="list-style-type: none"> Specify paint color number. Specify paint color number. Specify paint color number. <hr/> <ul style="list-style-type: none"> Specify paint color number. Specify paint color number. Specify paint color number.
Brackets <ul style="list-style-type: none"> • Off-module attachment brackets • One vertical off-module bracket +\$ 98 • Two vertical off-module brackets +\$196 <hr/> <ul style="list-style-type: none"> • Upmount brackets • Upmount kit +\$288 <hr/> <ul style="list-style-type: none"> • No brackets • Omit brackets -\$ 31 		<ul style="list-style-type: none"> Specify <i>with one vertical off-module bracket.</i> Specify <i>with two vertical off-module brackets.</i> <hr/> <ul style="list-style-type: none"> Specify <i>with upmount kit.</i> <hr/> <ul style="list-style-type: none"> Specify <i>omit brackets.</i>
Picture Frame Door on Flat Fronts <ul style="list-style-type: none"> • Omit insert Prices at right • Glass insert (assist mechanism recommended) Prices at right 		<ul style="list-style-type: none"> Specify <i>omit insert.</i> Specify <i>with glass insert.</i>
Door Mechanism <ul style="list-style-type: none"> • Assist mechanism for standard door, glass insert, or omit insert +\$288 per door 		<ul style="list-style-type: none"> Specify <i>with assist mechanism.</i>
Shelf Accessories <ul style="list-style-type: none"> • Four dividers: white plastic +\$ 76 		<ul style="list-style-type: none"> Specify <i>with dividers.</i>
Lock and Keying <ul style="list-style-type: none"> • Lock • No lock -\$104 per door • Ember Chrome No cost <hr/> <ul style="list-style-type: none"> • Keying • Factory- and field-installed keying 		<ul style="list-style-type: none"> Specify <i>with no lock.</i> Specify <i>with 9250 Ember Chrome lock.</i> <hr/> <ul style="list-style-type: none"> ▶ Page 686
Related Products <ul style="list-style-type: none"> • Accessories 		<ul style="list-style-type: none"> ▶ Page 614

Tip: Upmount brackets include steel back to enclose storage bin.

Tip: When ordering the omit insert option, remember that custom material cannot be factory installed. Custom material must be ordered from a material vendor.

Tip: Overhead storage bins and shelves with a "TAK" suffix can be used with Privacy Wall as well.
▶ See *Architectural Solutions Specification Guide* for attachment information.



For Canadian Pricing
Multiply U.S. Price by the Canadian price factor.
▶ See page 1 for details.

Specification Information						
Dimensions			Number of Doors	Style Number	U.S. Base Price	Options (Add \$ to Base Price)
D	W	H				
						Picture Frame Door Inserts
						Omit : Glass
						Insert : Insert

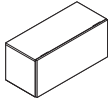

Tip: Overhead storage bins and shelves with a "TAK" suffix can be used with Privacy Wall as well.
▶ See Architectural Solutions Specification Guide for attachment information.

Bins with Flat Fronts

15¾"	24"	16¼"	1	RBB24QTAK	\$ 941	+\$403	+\$ 688
15¾"	30"	16¼"	1	RBB30QTAK	\$ 979	+\$425	+\$ 735
15¾"	36"	16¼"	1	RBB36QTAK	\$1026	+\$447	+\$ 780
15¾"	42"	16¼"	1	RBB42QTAK	\$1063	+\$464	+\$ 860
15¾"	48"	16¼"	1	RBB48QTAK	\$1098	+\$484	+\$ 938
15¾"	60"	16¼"	2	RBB60QTAK	\$1761	+\$795	+\$1398
15¾"	66"	16¼"	2	RBB66QTAK	\$1848	+\$813	+\$1482
15¾"	72"	16¼"	2	RBB72QTAK	\$1915	+\$831	+\$1562



For Canadian Pricing
Multiply U.S. Price by the Canadian price factor.
▶ See page 1 for details.

Universal In the Case Bins with Steel, Laminate, or Wood Flat Fronts

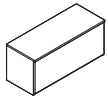

Standard Includes	Required to Specify
<ul style="list-style-type: none"> ▶ Need help? Product details, page 286 • Overhead bin with lift-up door: paint price group 1 • Door on units with laminate door fronts: laminate price group 1 • Door on units with wood door fronts: wood group 1 • Recess beneath unit to accommodate shelf light • Shelf backstop • On-module attachment brackets with safety catch: black paint only • Off-module attachment brackets, if selected: black paint only • Lock, keyed random: 9201 Polished Chrome 	<ol style="list-style-type: none"> 1 Style number 2 Paint color number for overhead bin 3 Laminate color number for door, if laminate door selected 4 Composite veneer or wood color number for door, if selected 5 Options, if selected (see below) <p>▶ See <i>Surface Materials</i>, page 668.</p>

Surface Materials	Options	U.S. Price	Required to Specify	
	Overhead bin with one steel door			
	• Paint price group 1	No cost	Specify paint color number.	
	• Paint price group 2	+\$ 65	Specify paint color number.	
	• Paint price group 3	+\$111	Specify paint color number.	
	Overhead bin with two steel doors			
	• Paint price group 1	No cost	Specify paint color number.	
	• Paint price group 2	+\$ 88	Specify paint color number.	
	• Paint price group 3	+\$155	Specify paint color number.	
	Overhead bin with one laminate or wood door			
	• Paint price group 1	No cost	Specify paint color number.	
	• Paint price group 2	+\$ 65	Specify paint color number.	
	• Paint price group 3	+\$101	Specify paint color number.	
• Laminate price group 1 on laminate door	Prices at right	Specify laminate color number.		
• Laminate price group 2 on laminate door	See information at left	Specify laminate color number.		
• Laminate price group 3 on laminate door	See information at left	Specify laminate color number.		
• Open Line laminate on laminate door	+\$102 plus cost of laminate	▶ See <i>Surface Materials Reference Manual</i> .		
• Composite veneer group 1 on wood door	Prices at right	Specify composite veneer color number.		
• Composite veneer group 2 on wood door	See information at left	Specify composite veneer color number.		
• Wood group 2 on wood door	See information at left	Specify wood color number.		
• Wood group 3 on wood door	See information at left	Specify wood color number.		
• Customiz stain on wood door	No cost	Specify <i>with Customiz stain</i> .		
		▶ See <i>Surface Materials Reference Manual</i> .		
Overhead bin with two laminate or wood doors				
• Paint price group 1	No cost	Specify paint color number.		
• Paint price group 2	+\$ 88	Specify paint color number.		
• Paint price group 3	+\$135	Specify paint color number.		
• Laminate price group 1 on laminate doors	Prices at right	Specify laminate color number.		
• Laminate price group 2 on laminate doors	See information at left	Specify laminate color number.		
• Laminate price group 3 on laminate doors	See information at left	Specify laminate color number.		
• Open Line laminate on laminate doors	+\$102 plus cost of laminate	▶ See <i>Surface Materials Reference Manual</i> .		
• Composite veneer group 1 on wood doors	Prices at right	Specify composite veneer color number.		
• Composite veneer group 2 on wood doors	See information at left	Specify composite veneer color number.		
• Wood group 2 on wood doors	See information at left	Specify wood color number.		
• Wood group 3 on wood doors	See information at left	Specify wood color number.		
• Customiz stain on wood doors	No cost	Specify <i>with Customiz stain</i> .		
		▶ See <i>Surface Materials Reference Manual</i> .		

For composite veneer, wood group 2, wood group 3, laminate price group 2, and laminate price group 3 pricing, please refer to the electronic catalog or SmartTools.

▶ Options, continued on next page

 **For Canadian Pricing**
Multiply U.S. Price by the Canadian price factor.
▶ See page 1 for details.

► Options, continued from previous page

	Options	U.S. Price	Required to Specify
Brackets	Off-module attachment brackets		
	• One vertical off-module bracket	+\$ 98	Specify with one vertical off-module bracket.
	• Two vertical off-module brackets	+\$196	Specify with two vertical off-module brackets.
	Upmount brackets		
	• Upmount kit	+\$288	Specify with upmount kit.
	No brackets		
	• Omit brackets	-\$ 31	Specify omit brackets.
Picture Frame Door on Flat Fronts	• Omit insert	Prices below	Specify omit insert.
Door Mechanism	• Assist mechanism for standard door or omit insert	+\$288 per door	Specify with assist mechanism.
Shelf Accessories	• Four dividers: white plastic	+\$ 76	Specify with dividers.
Lock and Keying	Lock		
	• No lock • Ember Chrome	-\$104 per door No cost	Specify with no lock. Specify with 9250 Ember Chrome lock.
	Keying		
	• Factory- and field-installed keying		► Page 686
Related Products	• Accessories		► Page 614

Tip: Upmount brackets include steel back to enclose storage bin.

Tip: When ordering the omit insert option, remember that custom material cannot be factory installed. Custom material must be ordered from a material vendor.

Tip: Overhead storage bins and shelves with a "TAK" suffix can be used with Privacy Wall as well.
► See Architectural Solutions Specification Guide for attachment information.

Specification Information

Dimensions			Number of Doors	Style Number	U.S. Base Price	Option (Add \$ to Base Price) Picture Frame Door —Omit Insert
D	W	H				

Bins with Steel Flat Fronts

15¾"	24"	16¼"	1	RBB24TAK	\$ 941	+\$403
15¾"	30"	16¼"	1	RBB30TAK	\$ 979	+\$425
15¾"	36"	16¼"	1	RBB36TAK	\$1026	+\$447
15¾"	42"	16¼"	1	RBB42TAK	\$1063	+\$464
15¾"	48"	16¼"	1	RBB48TAK	\$1098	+\$484
15¾"	60"	16¼"	2	RBB60TAK	\$1761	+\$795
15¾"	66"	16¼"	2	RBB66TAK	\$1848	+\$813
15¾"	72"	16¼"	2	RBB72TAK	\$1915	+\$831

► Specification Information, continued on next page

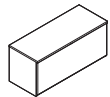

Tip: Overhead storage bins and shelves with a "TAK" suffix can be used with Privacy Wall as well.
► See Architectural Solutions Specification Guide for attachment information.



For Canadian Pricing
Multiply U.S. Price by the Canadian price factor.
► See page 1 for details.

Universal In the Case Bins with Steel, Laminate, or Wood Flat Fronts, continued

► Specification Information, continued from previous page

Specification Information

Dimensions			Number of Doors	Style Number	U.S. Base Price
D	W	H			

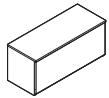

Bins with Laminate Flat Fronts

15¾"	24"	16¼"	1	RBB24LTAK	\$1493
15¾"	30"	16¼"	1	RBB30LTAK	\$1531
15¾"	36"	16¼"	1	RBB36LTAK	\$1578
15¾"	42"	16¼"	1	RBB42LTAK	\$1615
15¾"	48"	16¼"	1	RBB48LTAK	\$1650
15¾"	60"	16¼"	2	RBB60LTAK	\$2760
15¾"	66"	16¼"	2	RBB66LTAK	\$2847
15¾"	72"	16¼"	2	RBB72LTAK	\$2914

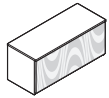

Bins with Composite Veneer Flat Fronts

15¾"	24"	16¼"	1	RBB24WTAK	\$1537
15¾"	30"	16¼"	1	RBB30WTAK	\$1575
15¾"	36"	16¼"	1	RBB36WTAK	\$1622
15¾"	42"	16¼"	1	RBB42WTAK	\$1659
15¾"	48"	16¼"	1	RBB48WTAK	\$1694
15¾"	60"	16¼"	2	RBB60WTAK	\$2804
15¾"	66"	16¼"	2	RBB66WTAK	\$2891
15¾"	72"	16¼"	2	RBB72WTAK	\$2958

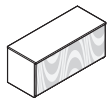

Bins with Wood Flat Fronts

15¾"	24"	16¼"	1	RBB24WTAK	\$1537
15¾"	30"	16¼"	1	RBB30WTAK	\$1575
15¾"	36"	16¼"	1	RBB36WTAK	\$1622
15¾"	42"	16¼"	1	RBB42WTAK	\$1659
15¾"	48"	16¼"	1	RBB48WTAK	\$1694
15¾"	60"	16¼"	2	RBB60WTAK	\$2804
15¾"	66"	16¼"	2	RBB66WTAK	\$2891
15¾"	72"	16¼"	2	RBB72WTAK	\$2958



For Canadian Pricing

Multiply U.S. Price by the Canadian price factor.

► See page 1 for details.

Universal Shelves

Universal Shelves

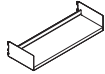

Standard Includes		Required to Specify
<ul style="list-style-type: none"> ▶ Need help? Product details, page 290 	<ul style="list-style-type: none"> • Shelf: paint price group 1 • Recess beneath unit to accommodate shelf light • Shelf backstop • On-module attachment hooks with safety catch 	<ul style="list-style-type: none"> 1 Style number 2 Paint color number for shelf 3 Options, if selected (see below) ▶ See <i>Surface Materials</i>, page 668.

Options	U.S. Price	Required to Specify
Surface Materials <ul style="list-style-type: none"> • Paint price group 1 • Paint price group 2 • Paint price group 3 	<ul style="list-style-type: none"> No cost +\$22 +\$36 	<ul style="list-style-type: none"> Specify paint color number. Specify paint color number. Specify paint color number.

Related Products <ul style="list-style-type: none"> • Accessories 	▶ Page 614
-----------------------------------------------------------------------------------------	------------

Specification Information				
Dimensions			Style Number	U.S. Base Price
D	W	H		
14 ³ / ₄ "	24"	7 ¹ / ₂ "	RSH24TAK	\$307
14 ³ / ₄ "	30"	7 ¹ / ₂ "	RSH30TAK	\$322
14 ³ / ₄ "	36"	7 ¹ / ₂ "	RSH36TAK	\$340
14 ³ / ₄ "	42"	7 ¹ / ₂ "	RSH42TAK	\$362
14 ³ / ₄ "	48"	7 ¹ / ₂ "	RSH48TAK	\$391
14 ³ / ₄ "	60"	7 ¹ / ₂ "	RSH60TAK	\$435
14 ³ / ₄ "	72"	7 ¹ / ₂ "	RSH72TAK	\$484
:	:	:	:	:

Tip: Overhead storage bins and shelves with a "TAK" suffix can be used with Privacy Wall as well.
▶ See *Architectural Solutions Specification Guide* for attachment information.

 **For Canadian Pricing**
Multiply U.S. Price by the Canadian price factor.
▶ See page 1 for details.

Accessories for Overhead Bins and Shelves

Universal Personal Shelves

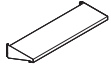

Tip: Overhead storage bins and shelves with a "TAK" suffix can be used with Privacy Wall as well.
 ▶ See Architectural Solutions Specification Guide for attachment information.

Standard Includes	Required to Specify
<ul style="list-style-type: none"> ▶ Need help? Product details, page 290 • Personal shelf: paint price group 1 • Recess beneath unit to accommodate shelf light • On-module attachment hooks 	<ul style="list-style-type: none"> 1 Style number 2 Paint color number for personal shelf 3 Options, if selected (see below) ▶ See <i>Surface Materials</i>, page 668.

Options	U.S. Price	Required to Specify
Surface Materials <ul style="list-style-type: none"> • Paint price group 1 • Paint price group 2 • Paint price group 3 	No cost +\$22 +\$36	Specify paint color number. Specify paint color number. Specify paint color number.

Specification Information			
Dimensions		Style Number	U.S. Base Price
D	W		
13 ¹ / ₁₆ "	24"	RDS24TAK	\$307
13 ¹ / ₁₆ "	30"	RDS30TAK	\$322
13 ¹ / ₁₆ "	36"	RDS36TAK	\$340
13 ¹ / ₁₆ "	42"	RDS42TAK	\$362
13 ¹ / ₁₆ "	48"	RDS48TAK	\$391

Dividers

For Use with Universal Sliding Door, Universal Over the Case, Universal In the Case, and Universal Shelves
 For Use with Hutch Kit



Standard Includes	Required to Specify
<ul style="list-style-type: none"> ▶ Need help? Product details, page 292 • Package of four dividers: white plastic only 	Style number

Specification Information	
Style Number	U.S. Price
RDIV	\$76



For Canadian Pricing
 Multiply U.S. Price by the Canadian price factor.
 ▶ See page 1 for details.

Dividers for Overhead Bin and Full-Height Shelf

For Use with Overhead Storage Products Introduced prior to March 2007



Standard Includes		Required to Specify
▶ Need help? Product details, page 292	• Carton of four dividers: clear textured plastic	Style number

Specification Information				
• Dimensions			• Style	• U.S.
D	W	H	Number	Price
10¾"	4"	4½"	TS7STDIV	\$85

Universal Vertical Off-Module Bracket

For Use with Universal Sliding Door, Universal Over the Case, and Universal In the Case Bins



Tip: For two-sided, off-module application, order two vertical off-module brackets.

Tip: Vertical off-module brackets are used with panels which have vertical slot patterns including Answer, Kick, and Montage.

Tip: For Montage, vertical off-module brackets can be used with 30"W to 60"W bins only.

Standard Includes		Required to Specify
▶ Need help? Product details, page 286	• Vertical off-module bracket with safety catch: black paint only	Style number

Specification Information	
• Style	• U.S.
Number	Price
RBKVOFM	\$95



For Canadian Pricing

Multiply U.S. Price by the Canadian price factor.

▶ See page 1 for details.

Standard Overhead Upmount Packages

For Use on Answer Panels

For Use with Universal Sliding Door, Universal Over the Case, and Universal In the Case Bins



Standard Includes	Required to Specify
<ul style="list-style-type: none"> ▶ Need help? Product details, page 287 • Pair of steel upmount brackets: paint price group 1 • Steel back to enclose storage bin 	<ul style="list-style-type: none"> 1 Style number 2 Paint color number for brackets and back 3 Options, if selected (see below) ▶ See <i>Surface Materials</i>, page 668.

Options	U.S. Price	Required to Specify
Surface Materials <ul style="list-style-type: none"> • Paint price group 1 • Paint price group 2 • Paint price group 3 	<ul style="list-style-type: none"> No cost +\$22 +\$36 	<ul style="list-style-type: none"> Specify paint color number. Specify paint color number. Specify paint color number.

Specification Information		
Width	Style Number	U.S. Base Price
24"	RUK24TAK	\$286
30"	RUK30TAK	\$286
36"	RUK36TAK	\$286
42"	RUK42TAK	\$286
48"	RUK48TAK	\$286
60"	RUK60TAK	\$286
72"	RUK72TAK	\$286
:	:	:



For Canadian Pricing

Multiply U.S. Price by the Canadian price factor.

▶ See page 1 for details.

Tackboards for Use with Wall Channels

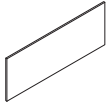

Standard Includes	Required to Specify
-------------------	---------------------

- | | |
|---------------------------------------------------------------------------------------------------------------------------------|------------------------------------------------------------------------------------------------------------------------------------------------------------------------------------------------|
| Standard Includes | Required to Specify |
| <ul style="list-style-type: none"> Tackboard, fabric direction with horizontal application: fabric price group 1 | <ul style="list-style-type: none"> 1 Style number 2 Fabric color number 3 Options, if selected (see below) ▶ See <i>Surface Materials</i>, page 668. |

Surface Materials	Options	U.S. Price	Required to Specify
-------------------	---------	------------	---------------------

- | | | | |
|-------------------|--------------------------------------------------------------------------------------------------------------------------------------------------------------------------------------------------------------------------------|--------------------------------------------------------------------------------------------------------------------------------------|------------------------------------------------------------------------------------------------------------------------------------------------------------------------------------------------------------------------------------------------------------------------------|
| Surface Materials | Options | U.S. Price | Required to Specify |
| | <ul style="list-style-type: none"> Fabric price group 1 Fabric price group 2 Fabric price group 3 Fabric price group 4 Fabric price group 5 Fabric price group COM | <ul style="list-style-type: none"> No cost +\$21 +\$39 +\$57 +\$87 +\$55 | <ul style="list-style-type: none"> Specify fabric color number. Specify fabric color number. Specify fabric color number. Specify fabric color number. Specify fabric color number. Specify fabric color number. |

Fabric direction on 24"W to 60"W tackboards

- | | | |
|------------------------------------------------------------------------|---------|------------------------------------|
| <ul style="list-style-type: none"> Vertical application | No cost | Specify with vertical application. |
|------------------------------------------------------------------------|---------|------------------------------------|

Tip: 72"W tackboards accommodate fabric in the horizontal direction only.

Tip: For further information about fabric direction, ▶ Page 674.

Specification Information			
Dimensions	Style		U.S. Base Price
	W	H	

Dimensions	Style		U.S. Base Price
	W	H	
24"	18"	TS71824TB	\$207
30"	18"	TS71830TB	\$229
36"	18"	TS71836TB	\$251
42"	18"	TS71842TB	\$275
48"	18"	TS71848TB	\$307
60"	18"	TS71860TB	\$389
72"	18"	TS71872TB	\$477
:	:	:	:

 **For Canadian Pricing**
Multiply U.S. Price by the Canadian price factor.
▶ See page 1 for details.

Flexible Markerboard Surface

For Use with Universal Over the Case Bins

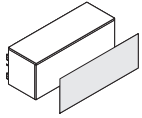

Tip: To order the flexible markerboard surface parametrically, please use style number TS7MBSP.

▶ Page 447

Standard Includes	Required to Specify
<ul style="list-style-type: none"> Flexible, magnetic markerboard surface to attach to door of overhead storage bin: white plastic 	Style number

Specification Information

• Dimensions		• Style	• U.S.
W	H	Number	Price
30"	16¼"	R30MBB	\$177
36"	16¼"	R36MBB	\$187
42"	16¼"	R42MBB	\$193
48"	16¼"	R48MBB	\$205
:	:	:	:



For Canadian Pricing

Multiply U.S. Price by the Canadian price factor.

▶ See page 1 for details.

Slim Shelves

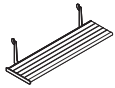

Standard Includes		Required to Specify
▶ Need help? Product details, page 293	<ul style="list-style-type: none"> Shelf: paint price group 1 Attachment brackets: paint to match shelf 	1 Style number 2 Paint color number for shelf 3 Options, if selected (see below) ▶ See <i>Surface Materials</i> , page 668.

Options	U.S. Price	Required to Specify
Surface Materials	<ul style="list-style-type: none"> Paint price group 1 Paint price group 2 Paint price group 3 	No cost +\$22 +\$36

Specification Information			
Dimensions		Style Number	U.S. Base Price
D	W		
6"	24"	RSS24TAK	\$319
6"	30"	RSS30TAK	\$340
6"	36"	RSS36TAK	\$364
6"	42"	RSS42TAK	\$391
6"	48"	RSS48TAK	\$416
6"	60"	RSS60TAK	\$521
6"	72"	RSS72TAK	\$570
6"	96"	RSS96TAK	\$671

Tip: Slim shelves with a "TAK" suffix can attach to Privacy Wall.
 ▶ See *Architectural Solutions Specification Guide* for attachment information.

 **For Canadian Pricing**
 Multiply U.S. Price by the Canadian price factor.
 ▶ See page 1 for details.

Universal One-High, 1.5-High, and Two Drawer Lateral Files

with Flush Steel, Proud Steel, Proud Laminate, Proud Wood, or Open Fronts

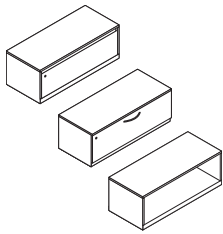

Tip: Service part Y30291SR, (paintable black plug), can be ordered to cover the glide adjustment holes in the front of the lateral file.

Standard Includes		Required to Specify
-------------------	--	---------------------

<p>▶ Need help? Product details, page 298</p>	<ul style="list-style-type: none"> • Lateral file: paint price group 1 • 1"H top on units with flush steel or proud steel fronts: paint to match file • Drawer fronts on units with proud laminate fronts: laminate price group 1 • Drawer fronts on units with proud wood fronts: wood group 1 veneer • Base (see below under Required Selections) • Pulls: metal • Integral pulls on units with flush steel fronts • Central lock, keyed random: 9201 Polished Chrome • One label holder per drawer: clear plastic • Drawer body: black only • Drawer suspensions: black only • One hanging folder bar per drawer on 18"D units • Two rails per drawer on 24"D units • Four adjustable leveling glides • Ganging hardware • Counterweight package, if selected 	<ol style="list-style-type: none"> 1 Style number with appropriate front style suffix in the space provided <ul style="list-style-type: none"> F Flush steel front P Proud steel front L Proud laminate front W Proud composite veneer or wood front 2 Paint color number for file 3 Laminate color number for drawer fronts, if proud laminate front selected 4 Wood color number for drawer fronts, if proud wood front selected 5 Base (see below under Required Selections) 6 Pull (see below under Required Selections) 7 Metal color number for pulls, if proud steel, proud laminate, or proud wood front selected 8 Options, if selected (see below) <ul style="list-style-type: none"> ▶ See <i>Surface Materials</i>, page 668.
-----------------------------------------------	------------------------------------------------------------------------------------------------------------------------------------------------------------------------------------------------------------------------------------------------------------------------------------------------------------------------------------------------------------------------------------------------------------------------------------------------------------------------------------------------------------------------------------------------------------------------------------------------------------------------------------------------------------------------------------------------------------------------------------------------------------------------------------------------------------------------------------------------------------------------------------------------------------------------	--------------------------------------------------------------------------------------------------------------------------------------------------------------------------------------------------------------------------------------------------------------------------------------------------------------------------------------------------------------------------------------------------------------------------------------------------------------------------------------------------------------------------------------------------------------------------------------------------------------------------------------------------------------------------------------------------------------------------------------------------------------------------------------------------------------------------------------------------------------------------------------------------------------------------------------------------------

Tip: Power infeed sits proud of the panel approximately 3" and will interfere with Universal storage with the Universal 3" base, FrameOne foot base, or c:scape glide.

Required Selections	U.S. Price	Required to Specify
---------------------	------------	---------------------

Bases	<ul style="list-style-type: none"> • Universal 3" base • FrameOne foot base • c:scape glide base 	<p>No cost</p> <p>+\$144</p> <p>+\$144</p> <p>Specify with <i>Universal 3" base</i>, painted to match tower.</p> <p>Specify with <i>FrameOne foot base</i>, painted to match tower.</p> <p>Specify with <i>c:scape glide base</i>, 4799 Platinum only.</p>
--------------	-----------------------------------------------------------------------------------------------------------------------------------	------------------------------------------------------------------------------------------------------------------------------------------------------------------------------------------------------------------------------------------------------------

Pulls

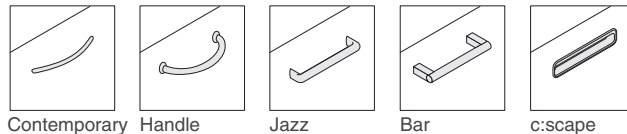

Options	U.S. Price	Required to Specify
---------	------------	---------------------

Surface Materials	<ul style="list-style-type: none"> • Paint price group 1 • Paint price group 2 • Paint price group 3 • Laminate price group 1 on proud laminate drawer fronts • Laminate price group 2 on proud laminate drawer fronts • Laminate price group 3 on proud laminate drawer fronts • Open Line laminate on proud laminate drawer fronts • Composite veneer group 1 on proud wood drawer fronts • Composite veneer group 2 on proud wood drawer fronts • Wood group 2 on proud wood drawer fronts • Wood group 3 on proud wood drawer fronts • Customiz stain on proud wood drawer fronts 	<p>No cost</p> <p>+\$111</p> <p>+\$192</p> <p>Prices at right</p> <p>See information at left</p> <p>See information at left</p> <p>+\$102 plus cost of laminate</p> <p>Prices at right</p> <p>See information at left</p> <p>See information at left</p> <p>See information at left</p> <p>See information at left</p> <p>No cost</p>	<p>Specify paint color number.</p> <p>Specify paint color number.</p> <p>Specify paint color number.</p> <p>Specify laminate color number.</p> <p>Specify laminate color number.</p> <p>Specify laminate color number.</p> <p>▶ See <i>Surface Materials Reference Manual</i>.</p> <p>Specify composite veneer color number.</p> <p>Specify composite veneer color number.</p> <p>Specify wood color number.</p> <p>Specify wood color number.</p> <p>Specify with <i>Customiz stain</i>.</p> <p>▶ See <i>Surface Materials Reference Manual</i>.</p>
--------------------------	---------------------------------------------------------------------------------------------------------------------------------------------------------------------------------------------------------------------------------------------------------------------------------------------------------------------------------------------------------------------------------------------------------------------------------------------------------------------------------------------------------------------------------------------------------------------------------------------------------------------------------------------------------------------------------------------------------	---------------------------------------------------------------------------------------------------------------------------------------------------------------------------------------------------------------------------------------------------------------------------------------------------------------------------------------	-------------------------------------------------------------------------------------------------------------------------------------------------------------------------------------------------------------------------------------------------------------------------------------------------------------------------------------------------------------------------------------------------------------------------------------------------------------------------------------------------------------------------------------------------------

For composite veneer, laminate and wood group 2 and 3 pricing, please refer to the electronic catalog or SmartTools.

▶ **Options, continued on next page**



For Canadian Pricing
Multiply U.S. Price by the Canadian price factor.
▶ See page 1 for details.

► Options, continued from previous page

Tip: Security top reduces overall height by approximately 1".

Tip: Laminate and wood veneer tops are 3/16" taller than other tops and will add 3/16" to overall case height.

For composite veneer, laminate and wood group 2 and 3 pricing, please refer to the electronic catalog or SmartTools.

	Options	U.S. Price	Required to Specify
Tops for Flush Steel Front and Proud Steel Front	Security top		
	• For use on 28"H lateral files only	No cost	Specify with <i>security top</i> .
	No top		
	• For use with a cushion top or beneath a common top	-\$147	Specify with <i>no top</i> .
	Laminate top		
	• Square edge laminate price group 1 top	+\$205	Specify with <i>laminate top</i> and indicate laminate color number for top and plastic color number for edges.
	• Square edge laminate price group 2 top	See information at left	Specify with <i>laminate top</i> and indicate laminate color number for top and plastic color number for edges.
	• Square edge laminate price group 3 top	See information at left	Specify with <i>laminate top</i> and indicate laminate color number for top and plastic color number for edges.
	• Open Line laminate on laminate top	+\$102 plus cost of laminate	► See <i>Surface Materials Reference Manual</i> .
	Composite veneer top		
	• Composite veneer group 1	+\$619	Specify with <i>composite veneer top</i> and indicate composite veneer color number.
	• Composite veneer group 2	See information at left	Specify with <i>composite veneer top</i> and indicate composite veneer color number.
	Tops for Proud Wood Front	Wood veneer top	
• Wood group 1		+\$619	Specify with <i>wood veneer top</i> and indicate wood color number.
• Wood group 2		See information at left	Specify with <i>wood veneer top</i> and indicate wood color number.
• Wood group 3		See information at left	Specify with <i>wood veneer top</i> and indicate wood color number.
• Customiz stain on wood veneer top		No cost	Specify with <i>Customiz stain</i> . ► See <i>Surface Materials Reference Manual</i> .
Security top			
• For use on 28"H lateral files only		-\$619	Specify with <i>security top</i> .
No top			
• For use with a cushion top or beneath a common top		-\$766	Specify with <i>no top</i> .
Laminate top			
• Square edge laminate price group 1 top	-\$414	Specify with <i>laminate top</i> and indicate laminate color number for top and plastic color number for edges.	
• Square edge laminate price group 2 top	See information at left	Specify with <i>laminate top</i> and indicate laminate color number for top and plastic color number for edges.	
• Square edge laminate price group 3 top	See information at left	Specify with <i>laminate top</i> and indicate laminate color number for top and plastic color number for edges.	
• Open Line laminate on laminate top	+\$102 plus cost of laminate	► See <i>Surface Materials Reference Manual</i> .	
Composite veneer top			
• Composite veneer group 1 veneer top	Prices at right	Specify with <i>composite veneer top</i> and indicate composite veneer color number.	
• Composite veneer group 2 veneer top	See information at left	Specify with <i>composite veneer top</i> and indicate composite veneer color number.	
Wood veneer top			
• Wood group 2 on proud wood top	See information at left	Specify wood color number.	
• Wood group 3 on proud wood top	See information at left	Specify wood color number.	
• Customiz stain on proud wood top	No cost	Specify with <i>Customiz stain</i> . ► See <i>Surface Materials Reference Manual</i> .	

For Canadian Pricing
Multiply U.S. Price by the Canadian price factor.
► See page 1 for details.

► Options, continued on next pages

Universal One-High, 1.5-High, and Two Drawer Lateral Files with Flush Steel, Proud Steel, Proud Laminate, Proud Wood, or Open Fronts, continued

► Options, continued from previous page

	Options	U.S. Price	Required to Specify
Tops for Proud Laminate Front	Security top • For use on 28"H lateral files only	-\$206	Specify with security top.
	No top • For use with a cushion top or beneath a common top	-\$414	Specify with no top.
	Laminate top • Laminate price group 2 on laminate top	See information at left	Specify laminate color number.
	• Laminate price group 3 on laminate top	See information at left	Specify laminate color number.
	• Open Line laminate on laminate top	+\$102 plus cost of laminate	► See <i>Surface Materials Reference Manual</i> .
	Composite veneer top • Composite veneer group 1 veneer top	+\$352	Specify with composite veneer top and indicate composite veneer color number.
	• Composite veneer group 2 veneer top	See information at left	Specify with composite veneer top and indicate composite veneer color number.
	Wood veneer top • Wood veneer top	+\$352	Specify with wood veneer top and indicate wood color number.
	• Wood group 2 top	See information at left	Specify wood color number.
	• Wood group 3 top	See information at left	Specify wood color number.
• Customiz stain top	No cost	Specify with Customiz stain. ► See <i>Surface Materials Reference Manual</i> .	
Drawer Interiors	• HF bar for use on 24"D units only	+\$ 22	Specify with HF bar.
	• Divider package	+\$ 40	Specify with divider package.
	• Rails for use on 18"D units only	+\$ 51	Specify with rails.
Pulls	Proud steel, laminate, or wood fronts • Contemporary	No cost	Specify with contemporary pull.
	• Handle	No cost	Specify with handle pull.
	• Jazz	+\$ 28 per pull	Specify with jazz pull.
	• Bar	+\$ 43 per pull	Specify with bar pull.
	Proud steel fronts only • c:scape	+\$ 48 per pull	Specify with c:scape pull.
Counterweights	One-High and 1.5-High lateral files with Universal 3" base		
	• Package 30	+\$329	Specify with counterweight.
	• Package 36	+\$329	Specify with counterweight.
	• Package 42	+\$329	Specify with counterweight.
	• Package D	+\$180	Specify with counterweight.
	• Package E	+\$235	Specify with counterweight.
	• Package F	+\$329	Specify with counterweight.
	One-High and 1.5-High lateral files with c:scape glide and FrameOne foot bases		
	• Package 30	+\$329	Specify with counterweight.
	• Package 36	+\$329	Specify with counterweight.
	• Package 42	+\$329	Specify with counterweight.
	Two Drawer with Universal 3" bases		
	• Package 3	+\$180	Specify with counterweight.
	• Package 4	+\$235	Specify with counterweight.
	Two Drawer with c:scape glide and FrameOne foot bases		
• Package 7	+\$329	Specify with counterweight.	
• Package 8	+\$329	Specify with counterweight.	

► Options, continued on next pages

Tip: 6"H box drawers come standard with a divider package.

For composite veneer, laminate and wood group 2 and 3 pricing, please refer to the electronic catalog or SmartTools.

Tip: 6"H box drawers come standard with a divider package.

Tip: Counterweight packages are required to ensure product stability and are ordered as an option or separately. Product specification pages indicate the correct counterweight package for each style number and any exceptions where counterweights are not required.

► See Counterweight Requirements for Storage Products, pages 265–272.

Tip: Height dimension listed is for units with 1" top. Overall height will vary if another top is selected.

Tip: Your specification is not complete until you add a suffix to the style number to define the front style (for example, RLF18301__ becomes RLF18301F for flush steel front).

► Options, continued from previous page

Options	U.S. Price	Required to Specify
Lock and Keying		
Lock		
• Ember Chrome	No cost	Specify with 9250 Ember Chrome lock.
Individual locking drawers		
• 18"D with two drawers	+\$196	Specify with individual lock.
• 24"D with two drawers	+\$220	Specify with individual lock.
Keying		
• Factory- and field-installed keying		► Page 686
Related Products		
• Cushion tops		► Page 626
• Field-installed tops		► Page 652
• Steel storage accessories		► Page 655
• Bookends		► Page 658
• Counterweight packages		► Page 660
• Low storage-to-beam tether bracket		► Page 625
• Basic cushions enhanced		► Page 627

Tip: Your specification is not complete until you add a suffix to the style number to define the front style (for example, RLF18301__ becomes RLF18301F for flush steel front).

Specification Information									
Dimensions		Counterweight Packages		Style Number	U.S. Base Prices				
D	W	H	Universal 3" Base	FrameOne Foot and c:scape Glide Bases	Flush Steel Front	Proud Steel Front	Proud Lam Front	Proud Comp Ven Front	Proud Wood Front
					Suffix F	Suffix P	Suffix L	Suffix W	Suffix W

One 12"H Drawer

18"	18 ⁷ / ₈ "	30"	16"	Package 30	Package 30	RLF18301__	\$1224	\$1260	\$1669	\$2468	\$2468
18"	18 ⁷ / ₈ "	36"	16"	Package 36	Package 36	RLF18361__	\$1356	\$1412	\$1812	\$2611	\$2611
18"	18 ⁷ / ₈ "	42"	16"	Package 42	Package 42	RLF18421__	\$1490	\$1554	\$1946	\$2745	\$2745

Open Configurations

18"	18 ⁷ / ₈ "	30"	16"	Not required	Not required	RSC18301A__	\$1051	\$1138	N.A.	N.A.	N.A.
18"	18 ⁷ / ₈ "	36"	16"	Not required	Not required	RSC18361A__	\$1230	\$1337	N.A.	N.A.	N.A.
18"	18 ⁷ / ₈ "	42"	16"	Not required	Not required	RSC18421A__	\$1397	\$1514	N.A.	N.A.	N.A.

Open-Open Configurations

One 6"H Opening with Fixed Shelf and One 12"H Opening with Fixed Shelf

18"	18 ⁷ / ₈ "	30"	22"	Not required	Not required	RLF18301A__	\$1104	\$1197	N.A.	N.A.	N.A.
18"	18 ⁷ / ₈ "	36"	22"	Not required	Not required	RLF18361A__	\$1327	\$1441	N.A.	N.A.	N.A.
18"	18 ⁷ / ₈ "	42"	22"	Not required	Not required	RLF18421A__	\$1539	\$1666	N.A.	N.A.	N.A.
23 ¹ / ₈ "	24"	30"	22"	Not required	Not required	RLF24301A__	\$1458	\$1576	N.A.	N.A.	N.A.
23 ¹ / ₈ "	24"	36"	22"	Not required	Not required	RLF24361A__	\$1741	\$1879	N.A.	N.A.	N.A.

► Specification Information, continued on next page

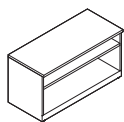
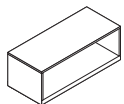
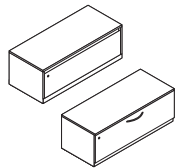

Tip: For open-open units, the shelf is affixed with screws. The screws can be removed to adjust the clips/shelf to a different height.

 **For Canadian Pricing**
Multiply U.S. Price by the Canadian price factor.
► See page 1 for details.

Universal One-High, 1.5-High, and Two Drawer Lateral Files with Flush Steel, Proud Steel, Proud Laminate, Proud Wood, or Open Fronts, continued

Tip: Height dimension listed is for units with 1" top. Over-all height will vary if another top is selected.

Tip: Your specification is not complete until you add a suffix to the style number to define the front style (for example, RLF18301__ becomes RLF18301F for flush steel front).

► Specification Information, continued from previous page

Specification Information										
Dimensions		Counterweight Packages		Style Number		U.S. Base Prices				
D	W	H				Flush Steel Front	Proud Steel Front	Proud Lam Front	Proud Comp Ven Front	Proud Wood Front
Flush Steel	Proud Steel/Lam/Comp Ven/Wood		Universal 3" Base	FrameOne Foot and c:scape Glide Bases		Suffix F	Suffix P	Suffix L	Suffix W	Suffix W

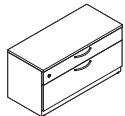

Drawer-Drawer Configurations

One 6"H Drawer and One 12"H Drawer

18"	18 ⁷ / ₈ "	30"	22"	Package 30	Package 30	RLF18301B__	\$1321	\$1416	\$2042	\$2841	\$2841
18"	18 ⁷ / ₈ "	36"	22"	Package 36	Package 36	RLF18361B__	\$1549	\$1657	\$2249	\$3048	\$3048
18"	18 ⁷ / ₈ "	42"	22"	Package 42	Package 42	RLF18421B__	\$1756	\$1885	\$2658	\$3457	\$3457
23 ¹ / ₈ "	24"	30"	22"	Package 30	Package 30	RLF24301B__	\$1679	\$1793	\$2619	\$3418	\$3418
23 ¹ / ₈ "	24"	36"	22"	Package 36	Package 36	RLF24361B__	\$1961	\$2102	\$2879	\$3678	\$3678

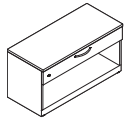

Drawer-Open Configurations

One 6"H Drawer and One 12"H Opening with Fixed Shelf

18"	18 ⁷ / ₈ "	30"	22"	Package D	Package D	RLF18301C__	\$1223	\$1315	\$1808	\$2607	\$2607
18"	18 ⁷ / ₈ "	36"	22"	Package E	Package E	RLF18361C__	\$1445	\$1550	\$2015	\$2814	\$2814
18"	18 ⁷ / ₈ "	42"	22"	Package F	Package F	RLF18421C__	\$1647	\$1775	\$2420	\$3219	\$3219
23 ¹ / ₈ "	24"	30"	22"	Package D	Package D	RLF24301C__	\$1567	\$1683	\$2386	\$3185	\$3185
23 ¹ / ₈ "	24"	36"	22"	Package E	Package E	RLF24361C__	\$1839	\$1973	\$2646	\$3445	\$3445

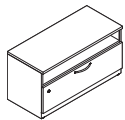

Open-Drawer Configurations

One 6"H Opening with Fixed Shelf and One 12"H Drawer

18"	18 ⁷ / ₈ "	30"	22"	Package 30	Package 30	RLF18301D__	\$1223	\$1315	\$1808	\$2607	\$2607
18"	18 ⁷ / ₈ "	36"	22"	Package 36	Package 36	RLF18361D__	\$1445	\$1550	\$2015	\$2814	\$2814
18"	18 ⁷ / ₈ "	42"	22"	Package 42	Package 42	RLF18421D__	\$1647	\$1775	\$2420	\$3219	\$3219
23 ¹ / ₈ "	24"	30"	22"	Package 30	Package 30	RLF24301D__	\$1567	\$1683	\$2386	\$3185	\$3185
23 ¹ / ₈ "	24"	36"	22"	Package 36	Package 36	RLF24361D__	\$1839	\$1973	\$2646	\$3445	\$3445

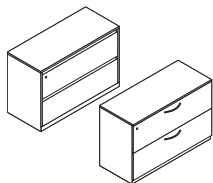

Two 12"H Drawers

18"	18 ⁷ / ₈ "	30"	28"	Package 3	Package 30	RLF18302__	\$1355	\$1448	\$2042	\$2841	\$2841
18"	18 ⁷ / ₈ "	36"	28"	Package 4	Package 30	RLF18362__	\$1586	\$1693	\$2253	\$3052	\$3052
18"	18 ⁷ / ₈ "	42"	28"	Package 4	Package 30	RLF18422__	\$1792	\$1922	\$2657	\$3456	\$3456
23 ¹ / ₈ "	24"	30"	28"	Package 3	Package 30	RLF24302__	\$1664	\$1779	\$2619	\$3418	\$3418
23 ¹ / ₈ "	24"	36"	28"	Package 4	Package 30	RLF24362__	\$1997	\$2132	\$2880	\$3679	\$3679



For Canadian Pricing
Multiply U.S. Price by the Canadian price factor.
► See page 1 for details.

Low Storage-to-Beam Tether Bracket

Low Storage-to-Beam
Tether Bracket



Standard Includes		Required to Specify
▶ Need help? Product details, page 300	<ul style="list-style-type: none"> • Pair of tether brackets: black • Attachment hardware 	Style number

Specification Information	
Style Number	U.S. Price
UFSTB	\$24

 **For Canadian Pricing**
Multiply U.S. Price by the
Canadian price factor.
▶ See page 1 for details.

Cushion Tops

For Universal One-High and 1.5-High Lateral Files

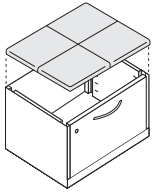

Tip: Seam pattern is determined by upholstery selected.

Tip: Your specification is not complete until you add a suffix to the style number to define the front style of the lateral (for example, RPDC1830__ becomes RPDC1830F for cushion top for flush steel front).

Standard Includes	Required to Specify
-------------------	---------------------

- | | | |
|------------------------------------------------------------------------------------------|--------------------------------------------------------------------------------------------------------|-------------------------------------------------------------------------------------------------------------------------------------------------------------------------------------------------------------------------------------------------------------------------------------------------------------------------------|
| <ul style="list-style-type: none"> ▶ Need help? Product details, page 301 | <ul style="list-style-type: none"> • Cushion top: fabric • Attachment hardware | <p>1 Style number with appropriate front style suffix in the space provided</p> <ul style="list-style-type: none"> F Flush steel front P Proud steel/wood front <p>2 Fabric color number</p> <p>3 Options, if selected (see below)</p> <p>▶ See <i>Surface Materials</i>, page 668.</p> |
|------------------------------------------------------------------------------------------|--------------------------------------------------------------------------------------------------------|-------------------------------------------------------------------------------------------------------------------------------------------------------------------------------------------------------------------------------------------------------------------------------------------------------------------------------|

Surface Materials	Options	U.S. Price	Required to Specify
-------------------	---------	------------	---------------------

Surface Materials	Options	U.S. Price	Required to Specify
	Upholstery		
	• Fabric price group 1	No cost	Specify fabric color number.
	• Fabric price group 2	+\$ 12	Specify fabric color number.
	• Fabric price group 3	+\$ 59	Specify fabric color number.
	• Fabric price group 4	+\$ 73	Specify fabric color number.
	• Fabric price group 5	+\$ 92	Specify fabric color number.
	• Fabric price group 6	+\$ 129	Specify fabric color number.
	• Fabric price group 7	+\$ 154	Specify fabric color number.
	• Fabric price group 8	+\$ 223	Specify fabric color number.
	• Fabric price group 9	+\$ 286	Specify fabric color number.
	• Fabric price group 10	+\$ 348	Specify fabric color number.
	• Leather price group	+\$ 894	Specify leather color number.
	• Select Surfaces leather price group 1	+\$ 894	▶ See <i>Surface Materials Reference Manual</i> .
	• Elmosoft leather price group	+\$1030	Specify Elmosoft leather color number.
	• Select Surfaces leather price group 2	+\$1030	▶ See <i>Surface Materials Reference Manual</i> .
	• Vinyl	+\$ 12	Specify vinyl color number.
	• Customer's Own Material (COM) or Customer's Own Leather (COL)	+\$ 23	▶ See <i>Surface Materials Reference Manual</i> .

Related Products	• Universal One-High lateral files	▶ Page 620
	• Universal 1.5-High lateral files	▶ Page 620

Specification Information

• Dimensions		• Style		• U.S. Base Price	
D	W H	Number		Flush Steel Front	Proud Steel/Wood Front
.....	Suffix F	Suffix P

Cushion Tops

18"	18 ⁷ / ₈ "	30"	1 ¹ / ₂ "	RPDC1830__	\$ 950	\$ 950
18"	18 ⁷ / ₈ "	36"	1 ¹ / ₂ "	RPDC1836__	\$ 968	\$ 968
18"	18 ⁷ / ₈ "	42"	1 ¹ / ₂ "	RPDC1842__	\$ 985	\$ 985
23 ¹ / ₈ "	24"	30"	1 ¹ / ₂ "	RPDC2430__	\$1008	\$1008
23 ¹ / ₈ "	24"	36"	1 ¹ / ₂ "	RPDC2436__	\$1026	\$1026



For Canadian Pricing
Multiply U.S. Price by the Canadian price factor.
▶ See page 1 for details.

Basic Cushions Enhanced

For Universal Lateral Files

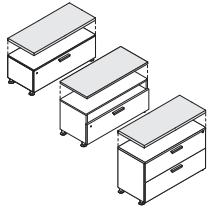

Tip: Basic cushion enhanced is field-installed and supplies to attach are included.

Tip: Basic cushion enhanced is constructed with a thin solid base.

Tip: Basic cushion enhanced is available on Universal laterals with a top only.

Standard Includes		Required to Specify	
▶ Need help? Product details, page 298	<ul style="list-style-type: none"> Enhanced cushion top: fabric price group 1 Attachment supplies: hook and loop fastener 	1 Style number	2 Fabric color number for cushion top 3 Options, if selected (see below) ▶ See <i>Surface Materials</i> , page 668.

Options	U.S. Price	Required to Specify
Surface Materials		
Upholstery		
• Fabric price group 1	No cost	Specify fabric color number.
• Fabric price group 2	+\$ 12	Specify fabric color number.
• Fabric price group 3	+\$ 59	Specify fabric color number.
• Fabric price group 4	+\$ 73	Specify fabric color number.
• Fabric price group 5	+\$ 92	Specify fabric color number.
• Fabric price group 6	+\$129	Specify fabric color number.
• Fabric price group 7	+\$154	Specify fabric color number.
• Fabric price group 8	+\$223	Specify fabric color number.
• Fabric price group 9	+\$286	Specify fabric color number.
• Fabric price group 10	+\$348	Specify fabric color number.
• Customer's Own Material (COM)	+\$ 23	▶ See <i>Surface Materials Reference Manual</i> .
Support Brace	For 30"W and 36"W steel Universal laterals with an open configuration	
• Brace (30"W and 36"W)	+\$ 77	Specify <i>with brace</i> .
Related Products	• Universal laterals files	▶ Page 620

Specification Information				
• Dimensions			• Style Number	• U.S. Base Price
D	W	H		
18"	30"	1"	RCHE1830	\$374
18"	36"	1"	RCHE1836	\$397
18"	42"	1"	RCHE1842	\$420
23 1/8"	30"	1"	RCHE2430	\$427
23 1/8"	36"	1"	RCHE2436	\$443
.

 **For Canadian Pricing**
Multiply U.S. Price by the Canadian price factor.
▶ See page 1 for details.

Universal Open Side Towers

with Flush Steel, Proud Steel, Proud Laminate, or Proud Wood Fronts

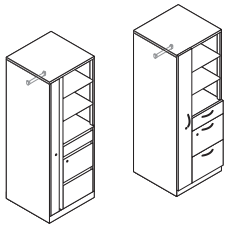

► Need help?
Product details,
page 302

Standard Includes

- Tower: paint price group 1
- 1"H top: paint to match tower
- Door and drawer fronts on units with proud laminate fronts: laminate price group 1
- Door and drawer fronts on units with proud wood fronts: wood group 1 veneer
- Lock, keyed random: 9201 Polished Chrome
- Base (see below under required selections)
- Pulls: metal
- Integral pulls on units with flush steel fronts
- Drawer body: black only
- Adjustable shelves on 52"H and 65½"H: paint to match tower
- Brackets for adjustable shelves: black
- Post to support adjustable shelf: paint to match tower
- One box drawer divider and one pencil tray: black only
- Coat rod: black
- Four adjustable leveling glides
- Ganging hardware
- Counterweight package, if selected

Required to Specify

- 1 Style number with appropriate front style suffix in the space provided
 - F** Flush steel front
 - P** Proud steel front
 - L** Proud laminate front
 - W** Proud composite veneer or wood front
 - 2 Paint color number for tower
 - 3 Laminate color number for door and drawer fronts, if proud laminate front selected
 - 4 Wood color number for door and drawer fronts, if proud wood front selected
 - 5 Base (see below under required selections)
 - 6 Pull (see below under required selections)
 - 7 Metal color number for pulls, if proud steel, proud laminate, or proud wood front selected
 - 8 Options, if selected (see below)
- See *Surface Materials*, page 668.

	Required Selections	U.S. Price	Required to Specify
Bases	• Universal 3" base	No cost	Specify with <i>Universal 3" base</i> , painted to match tower.
	• FrameOne foot base	+\$286	Specify with <i>FrameOne foot base</i> , painted to match tower.
	• c:scape glide base	+\$286	Specify with <i>c:scape glide base</i> , 4799 Platinum Metallic only.

Pulls

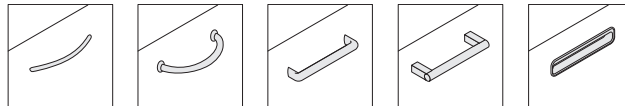

Contemporary Handle Jazz Bar c:scape

	Options	U.S. Price	Required to Specify
Surface Materials	• Paint price group 1	No cost	Specify paint color number.
	• Paint price group 2	+\$111	Specify paint color number.
	• Paint price group 3	+\$192	Specify paint color number.
	• Laminate price group 1 on proud laminate fronts	Prices at right	Specify laminate color number.
	• Laminate price group 2 on proud laminate fronts	See information at left	Specify laminate color number.
	• Laminate price group 3 on proud laminate fronts	See information at left	Specify laminate color number.
	• Open Line laminate on proud laminate fronts	+\$102 plus cost of laminate	► See <i>Surface Materials Reference Manual</i> .
	• Composite veneer group 1 on proud wood fronts	Prices at right	Specify composite veneer color number.
	• Composite veneer group 2 on proud wood fronts	See information at left	Specify composite veneer color number.
	• Wood group 2 on proud wood fronts	See information at left	Specify wood color number.
	• Wood group 3 on proud wood fronts	See information at left	Specify wood color number.
	• Customiz stain on proud wood fronts	No cost	Specify with <i>Customiz stain</i> . ► See <i>Surface Materials Reference Manual</i> .

► Options, continued on next page

For composite veneer, laminate and wood group 2 and 3 pricing, please refer to the electronic catalog or SmartTools.

Tip: Laminate and wood veneer tops are 3/16" taller than other tops and will add 3/16" to overall case height.



For Canadian Pricing
Multiply U.S. Price by the Canadian price factor.
► See page 1 for details.

► Options, continued from previous page

	Options	U.S. Price	Required to Specify
Tops for Flush Steel Front, Proud Steel Front, Proud Laminate Front, and Proud Wood Front	Laminate top		
	• Square edge laminate price group 1 top	+\$205	Specify with <i>laminate top</i> and indicate laminate color number for top and plastic color number for edges.
	• Square edge laminate price group 2 top	See information at left	Specify with <i>laminate top</i> and indicate laminate color number for top and plastic color number for edges.
	• Square edge laminate price group 3 top	See information at left	Specify with <i>laminate top</i> and indicate laminate color number for top and plastic color number for edges.
	• Open Line laminate on laminate top	+\$102 plus cost of laminate	► See <i>Surface Materials Reference Manual</i> .
	Composite veneer top		
	• Composite veneer group 1	+\$619	Specify with <i>composite veneer top</i> and indicate composite veneer color number.
	• Composite veneer group 2	See information at left	Specify with <i>composite veneer top</i> and indicate composite veneer color number.
	Wood veneer top		
	• Wood group 1	+\$619	Specify with <i>wood veneer top</i> and indicate wood color number.
	• Wood group 2	See information at left	Specify with <i>wood veneer top</i> and indicate wood color number.
	• Wood group 3	See information at left	Specify with <i>wood veneer top</i> and indicate wood color number.
	• Customiz stain on wood veneer top on units with flush steel or proud steel fronts	No cost	Specify with <i>Customiz stain</i> . ► See <i>Surface Materials Reference Manual</i> .
	Pulls		
	Proud steel, laminate, or wood fronts		
	• Contemporary	No cost	Specify with <i>contemporary pull</i> .
	• Handle	No cost	Specify with <i>handle pull</i> .
	• Jazz	+\$ 28 per pull	Specify with <i>jazz pull</i> .
	• Bar	+\$ 43 per pull	Specify with <i>bar pull</i> .
	Proud steel fronts only		
	• c:scape	+\$ 48 per pull	Specify with <i>c:scape pull</i> .
	Counterweights		
	• Tower package 1	+\$161	Specify with <i>counterweight</i> .
	• Tower package 2	+\$198	Specify with <i>counterweight</i> .
	Lock and Keying		
	Lock		
	• Ember Chrome	No cost	Specify with <i>9250 Ember Chrome lock</i> .
	Keying		
	• Factory- and field-installed keying		► Page 686
	Related Products		
	• Field-installed tops		► Page 650
	• Adjustable shelves		► Page 654
	• Counterweights		► Page 660
	• Steel storage accessories		► Page 655
	• Bookends		► Page 658

For composite veneer, laminate and wood group 2 and 3 pricing, please refer to the electronic catalog or SmartTools.

Tip: If wood veneer top option is selected, wood veneer top color will default to match wood front.

*Tip: Counterweight packages are required to ensure product stability and are ordered as an option or separately. Product specification pages indicate the correct counterweight package for each style number and any exceptions where counterweights are not required.
► See Counterweight Requirements for Storage Products, pages 265–272.*

Tip: Height dimension listed is for units with 1" top. Over-all height will vary if another top is selected.

*Tip: Your specification is not complete until you add a suffix to the style number to define the front style (for example, **RQS24244LA** becomes **RQS24244LAF** for flush steel front).*

► Specification Information, on next page

Universal Open Side Towers with Flush Steel, Proud Steel, or Proud Wood Fronts, continued

► Options, on previous page

Specification Information

Dimensions		Style Number	U.S. Base Prices					Counterweights			
D	W H		Flush Steel Front	Proud Steel Front	Proud Lam Front	Proud Comp Ven Front	Proud Wood Front	Steel Fronts		Lam/Comp Ven or Wood Fronts	
								Universal 3" Base	FrameOne Foot and c:scape Glide Bases	Universal 3" Base	FrameOne Foot and c:scape Glide Bases
Flush Steel Front	Proud Steel/Lam/Comp Ven/Wood Front										
			Suffix F	Suffix P	Suffix L	Suffix W	Suffix W				

Tower with Door Hinged on Left

One 6"H Drawer and Two 12"H Drawers

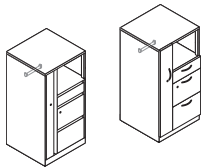

18"	18 7/8"	24" 47 1/2"	RQS182448LA__	\$3063	\$3560	\$4046	\$4251	\$4251	Tower package 1	Tower package 1	Tower package 2	Tower package 2
23 1/8"	24"	24" 47 1/2"	RQS242448LA__	\$3394	\$3891	\$4377	\$4582	\$4582	Not required	Tower package 1	Not required	Tower package 1

One Adjustable Shelf, One 6"H Drawer, and Two 12"H Drawers

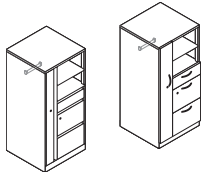

18"	18 7/8"	24" 52"	RQS18244LA__	\$3166	\$3663	\$4149	\$4354	\$4354	Tower package 1	Tower package 1	Tower package 1	Tower package 1
23 1/8"	24"	24" 52"	RQS24244LA__	\$3523	\$4020	\$4506	\$4711	\$4711	Not required	Not required	Not required	Not required

Two Adjustable Shelves, One 6"H Drawer, and Two 12"H Drawers

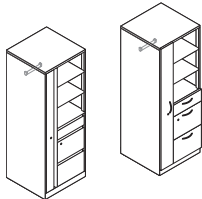

18"	18 7/8"	24" 65 1/2"	RQS18245LC__	\$3736	\$4233	\$4719	\$4924	\$4924	Tower package 1	Tower package 1	Tower package 1	Tower package 1
23 1/8"	24"	24" 65 1/2"	RQS24245LC__	\$4153	\$4650	\$5136	\$5341	\$5341	Not required	Not required	Not required	Not required

► Specification Information, continued on next page



For Canadian Pricing

Multiply U.S. Price by the Canadian price factor.

► See page 1 for details.

► Specification Information, continued from previous page

Specification Information													
Dimensions			Style Number	U.S. Base Prices					Counterweights				
D	W	H		Flush Steel Front	Proud Steel Front	Proud Lam Front	Proud Comp Ven Front	Proud Wood Front	Steel Fronts		Lam/Comp Ven or Wood Fronts		
Flush Steel Front	Proud Steel/Lam/Comp Ven/Wood Front		Suffix F	Suffix P	Suffix L	Suffix W	Suffix W	Universal 3" Base	FrameOne Foot and c:scape Glide Bases	Universal 3" Base	FrameOne Foot and c:scape Glide Bases		

Tower with Door Hinged on Right

One 6"H Drawer and Two 12"H Drawers

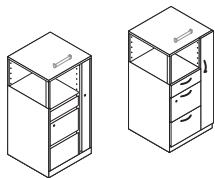

18"	18 ⁷ / ₈ "	24"	47 ¹ / ₂ "	RQS182448RA	\$3063	\$3560	\$4046	\$4251	\$4251	Tower package 1	Tower package 1	Tower package 2	Tower package 2
23 ¹ / ₈ "	24"	24"	47 ¹ / ₂ "	RQS242448RA	\$3394	\$3891	\$4377	\$4582	\$4582	Not required	Tower package 1	Not required	Tower package 1

One Adjustable Shelf, One 6"H Drawer, and Two 12"H Drawers

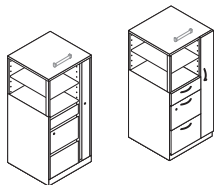

18"	18 ⁷ / ₈ "	24"	52"	RQS18244RA	\$3166	\$3663	\$4149	\$4354	\$4354	Tower package 1	Tower package 1	Tower package 1	Tower package 1
23 ¹ / ₈ "	24"	24"	52"	RQS24244RA	\$3523	\$4020	\$4506	\$4711	\$4711	Not required	Not required	Not required	Not required

Two Adjustable Shelves, One 6"H Drawer, and Two 12"H Drawers

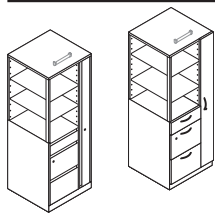

18"	18 ⁷ / ₈ "	24"	65 ¹ / ₂ "	RQS18245RC	\$3736	\$4233	\$4719	\$4924	\$4924	Tower package 1	Tower package 1	Tower package 1	Tower package 1
23 ¹ / ₂ "	24"	24"	65 ¹ / ₂ "	RQS24245RC	\$4153	\$4650	\$5136	\$5341	\$5341	Not required	Not required	Not required	Not required

► Specification Information, continued on next page



For Canadian Pricing

Multiply U.S. Price by the Canadian price factor.

► See page 1 for details.

Universal Dual Door Towers

with Flush Steel, Proud Steel, Proud Laminate, or Proud Wood Fronts

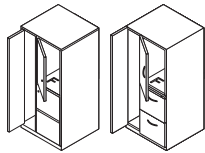

▶ Need help?
Product details,
page 302

Standard Includes

- Tower: paint price group 1
- 1"H top: paint to match tower
- Door and drawer fronts on units with proud laminate fronts: laminate price group 1
- Door and drawer fronts on units with proud wood fronts: wood group 1 veneer
- Lock, keyed random: 9201 Polished Chrome
- Base (see below under Required Selections)
- Pulls: metal
- Integral pulls on units with flush steel fronts
- Drawer body: black only
- Adjustable shelves on 52"H and 65½"H:
paint to match tower
- Brackets for adjustable shelves: black
- Post to support adjustable shelf: paint to match tower
- One box drawer divider and one pencil tray: black only
- Coat rod: black
- Four adjustable leveling glides
- Ganging hardware
- Counterweight package, if selected

Required to Specify

- 1 Style number with appropriate front style suffix in the space provided
 - F** Flush steel front
 - P** Proud steel front
 - L** Proud laminate front
 - W** Proud composite veneer or wood front
 - 2 Paint color number for tower
 - 3 Laminate color number for door and drawer fronts, if proud laminate front selected
 - 4 Wood color number for door and drawer fronts, if proud wood front selected
 - 5 Base (see below under Required Selections)
 - 6 Pull (see below under Required Selections)
 - 7 Metal color number for pulls, if proud steel, proud laminate, or proud wood front selected
 - 8 Options, if selected (see below)
- ▶ See *Surface Materials*, page 668.

	Required Selections	U.S. Price	Required to Specify
Bases	• Universal 3" base	No cost	Specify with <i>Universal 3" base</i> , painted to match tower.
	• FrameOne foot base	+\$286	Specify with <i>FrameOne foot base</i> , painted to match tower.
	• c:scape glide base	+\$286	Specify with <i>c:scape glide base</i> , 4799 Platinum Metallic only.

Pulls

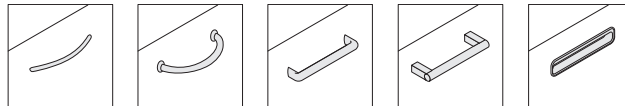

Contemporary Handle Jazz Bar c:scape

	Options	U.S. Price	Required to Specify
Surface Materials	• Paint price group 1	No cost	Specify paint color number.
	• Paint price group 2	+\$111	Specify paint color number.
	• Paint price group 3	+\$192	Specify paint color number.
	• Laminate price group 1 on proud laminate fronts	Prices at right	Specify laminate color number.
	• Laminate price group 2 on proud laminate fronts	See information at left	Specify laminate color number.
	• Laminate price group 3 on proud laminate fronts	See information at left	Specify laminate color number.
	• Open Line laminate on proud laminate fronts	+\$102 plus cost of laminate	▶ See <i>Surface Materials Reference Manual</i> .
	• Composite veneer group 1 on proud wood fronts	Prices at right	Specify composite veneer color number.
	• Composite veneer group 2 on proud wood fronts	See information at left	Specify composite veneer color number.
	• Wood group 2 on proud wood fronts	See information at left	Specify wood color number.
	• Wood group 3 on proud wood fronts	See information at left	Specify wood color number.
	• Customiz stain on proud wood fronts	No cost	Specify with Customiz stain. ▶ See <i>Surface Materials Reference Manual</i> .

▶ Options, continued on next page

For composite veneer, laminate and wood group 2 and 3 pricing, please refer to the electronic catalog or SmartTools.

Tip: Laminate and wood veneer tops are 3/16" taller than other tops and will add 3/16" to overall case height.



For Canadian Pricing

Multiply U.S. Price by the Canadian price factor.

▶ See page 1 for details.

► Options, continued from previous page

	Options	U.S. Price	Required to Specify
Tops for Flush Steel Front, Proud Steel Front, Proud Laminate Front, and Proud Wood Front	Laminate top		
	• Square edge laminate price group 1 top	+\$205	Specify with <i>laminate top</i> and indicate laminate color number for top and plastic color number for edges.
	• Square edge laminate price group 2 top	See information at left	Specify with <i>laminate top</i> and indicate laminate color number for top and plastic color number for edges.
	• Square edge laminate price group 3 top	See information at left	Specify with <i>laminate top</i> and indicate laminate color number for top and plastic color number for edges.
	• Open Line laminate on laminate top	+\$102 plus cost of laminate	► See <i>Surface Materials Reference Manual</i> .
	Composite veneer top		
	• Composite veneer group 1	+\$619	Specify with <i>composite veneer top</i> and indicate composite veneer color number.
	• Composite veneer group 2	See information at left	Specify with <i>composite veneer top</i> and indicate composite veneer color number.
	Wood veneer top		
	• Wood group 1 veneer top	+\$619	Specify with <i>wood veneer top</i> and indicate wood color number.
	• Wood group 2 veneer top	See information at left	Specify with <i>wood veneer top</i> and indicate wood color number.
	• Wood group 3 veneer top	See information at left	Specify with <i>wood veneer top</i> and indicate wood color number.
	• Customiz stain on wood veneer top on units with flush steel or proud steel fronts	No cost	Specify with <i>Customiz stain</i> . ► See <i>Surface Materials Reference Manual</i> .
	Pulls		
	Proud steel, laminate, or wood fronts		
	• Contemporary	No cost	Specify with <i>contemporary pull</i> .
	• Handle	No cost	Specify with <i>handle pull</i> .
	• Jazz	+\$ 28 per pull	Specify with <i>jazz pull</i> .
	• Bar	+\$ 43 per pull	Specify with <i>bar pull</i> .
	Proud steel fronts only		
	• c:scape	+\$ 48 per pull	Specify with <i>c:scape pull</i> .
	Counterweights		
	• Tower package 1	+\$161	Specify with <i>counterweight</i> .
	• Tower package 2	+\$198	Specify with <i>counterweight</i> .
	Lock and Keying		
	Lock		
	• Ember Chrome	No cost	Specify with <i>9250 Ember Chrome lock</i> .
	Keying		
	• Factory- and field-installed keying		► Page 686
	Related Products		
	• Field-installed tops		► Page 650
	• Adjustable shelves		► Page 654
	• Counterweights		► Page 660
	• Steel storage accessories		► Page 655

For composite veneer, laminate and wood group 2 and 3 pricing, please refer to the electronic catalog or SmartTools.

Tip: If wood veneer top option is selected, wood veneer top color will default to match wood front.

Tip: Height dimension listed is for units with 1" top. Overall height will vary if another top is selected.

Tip: Counterweight packages are required to ensure product stability and are ordered as an option or separately. Product specification pages indicate the correct counterweight package for each style number and any exceptions where counterweights are not required. ► See Counterweight Requirements for Storage Products, pages 265–272.

Tip: Your specification is not complete until you add a suffix to the style number to define the front style (for example, RDD182448LA becomes RDD182448LAF for flush steel front).

 **For Canadian Pricing**
Multiply U.S. Price by the Canadian price factor.
► See page 1 for details.

► Specification Information, on next page

Universal Steel Storage

Universal Dual Door Towers with Flush Steel, Proud Steel, Proud Laminate, or Proud Wood Fronts, continued

► **Options, on previous page**

Specification Information

Dimensions		Style Number	U.S. Base Prices					Counterweights			
D	W H		Flush Steel Front	Proud Steel Front	Proud Lam Front	Proud Comp Ven Front	Proud Wood Front	Steel Fronts		Lam/Comp Ven or Wood Fronts	
Flush Steel Front	Proud Steel/Lam/Comp Ven/Wood Front		Suffix F	Suffix P	Suffix L	Suffix W	Suffix W	Universal 3" Base	FrameOne Foot and c:scape Glide Bases	Universal 3" Base	FrameOne Foot and c:scape Glide Bases

Tower with Doors Hinged on Left

One Fixed Shelf and Two 12"H Drawers

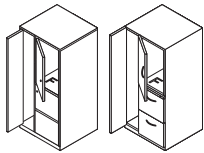

18"	18 ⁷ / ₈ "	24" 47 ¹ / ₂ "	RDD182448LA	\$2700	\$3135	\$3536	\$3741	\$3741	Tower package 1	Tower package 1	Tower package 2	Tower package 2
23 ¹ / ₈ "	24"	24" 47 ¹ / ₂ "	RDD242448LA	\$3253	\$3410	\$3826	\$4031	\$4031	Not required	Tower package 1	Not required	Tower package 1

One Fixed Shelf, Two 6"H Drawers, and One 12"H Drawer

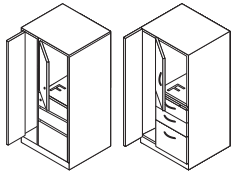

18"	18 ⁷ / ₈ "	24" 47 ¹ / ₂ "	RDD182448LB	\$2940	\$3387	\$3797	\$4002	\$4002	Tower package 1	Tower package 1	Tower package 2	Tower package 2
23 ¹ / ₈ "	24"	24" 47 ¹ / ₂ "	RDD242448LB	\$3482	\$3652	\$4094	\$4299	\$4299	Not required	Tower package 1	Not required	Tower package 1

One Fixed Shelf, One Adjustable Shelf, and Two 12"H Drawers

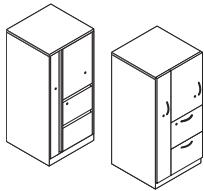

18"	18 ⁷ / ₈ "	24" 52"	RDD18244LA	\$2985	\$3391	\$3785	\$3990	\$3990	Tower package 1	Tower package 1	Tower package 1	Tower package 1
23 ¹ / ₈ "	24"	24" 52"	RDD24244LA	\$3515	\$3704	\$4048	\$4253	\$4253	Not required	Not required	Not required	Not required

► **Specification Information, continued on next page**



For Canadian Pricing

Multiply U.S. Price by the Canadian price factor.

► See page 1 for details.

► Specification Information, continued from previous page

Specification Information												
Dimensions			Style Number	U.S. Base Prices					Counterweights			
D	W	H		Flush Steel Front	Proud Steel Front	Proud Lam Front	Proud Comp Ven Front	Proud Wood Front	Steel Fronts		Lam/Comp Ven or Wood Fronts	
Flush Steel Front	Proud Steel/Lam/Comp Ven/Wood Front		Suffix F	Suffix P	Suffix L	Suffix W	Suffix W	Universal 3" Base	FrameOne Foot and c:scape Glide Bases	Universal 3" Base	FrameOne Foot and c:scape Glide Bases	

Tower with Doors Hinged on Left, continued

One Fixed Shelf, One Adjustable Shelf, Two 6"H Drawers, and One 12"H Drawer

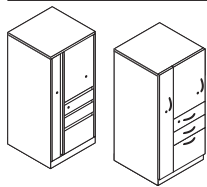

18"	18 ⁷ / ₈ "	24"	52"	RDD18244LB__	\$3181	\$3493	\$3982	\$4187	\$4187	Tower package 1	Tower package 1	Tower package 1	Tower package 1
23 ¹ / ₈ "	24"	24"	52"	RDD24244LB__	\$3710	\$3793	\$4293	\$4498	\$4498	Not required	Not required	Not required	Not required

One Fixed Shelf, Two Adjustable Shelves, and Two 12"H Drawers

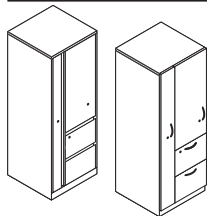

18"	18 ⁷ / ₈ "	24"	65 ¹ / ₂ "	RDD18245LC__	\$3349	\$3816	\$4204	\$4409	\$4409	Tower package 1	Tower package 1	Tower package 1	Tower package 1
23 ¹ / ₈ "	24"	24"	65 ¹ / ₂ "	RDD24245LC__	\$3710	\$3842	\$4580	\$4785	\$4785	Not required	Not required	Not required	Not required

One Fixed Shelf, Two Adjustable Shelves, Two 6"H Drawers, and One 12"H Drawer

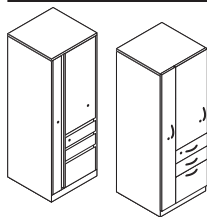

18"	18 ⁷ / ₈ "	24"	65 ¹ / ₂ "	RDD18245LD__	\$3544	\$3988	\$4400	\$4605	\$4605	Tower package 1	Tower package 1	Tower package 1	Tower package 1
23 ¹ / ₈ "	24"	24"	65 ¹ / ₂ "	RDD24245LD__	\$3906	\$4036	\$4781	\$4986	\$4986	Not required	Not required	Not required	Not required

► Specification Information, continued on next page



For Canadian Pricing

Multiply U.S. Price by the Canadian price factor.

► See page 1 for details.

Universal Steel Storage

Universal Dual Door Towers with Flush Steel, Proud Steel, Proud Laminate, or Proud Wood Fronts, continued

► **Specification Information, continued from previous page**

Specification Information												
Dimensions			Style Number	U.S. Base Prices					Counterweights			
D	W	H		Flush Steel Front	Proud Steel Front	Proud Lam Front	Proud Comp Ven Front	Proud Wood Front	Steel Fronts		Lam/Comp Ven or Wood Fronts	
Flush Steel Front	Proud Steel/Lam/Comp Ven/Wood Front								Universal 3" Base	FrameOne Foot and c:scape Glide Bases	Universal 3" Base	FrameOne Foot and c:scape Glide Bases
			Suffix F	Suffix P	Suffix L	Suffix W	Suffix W					

Tower with Doors Hinged on Right

One Fixed Shelf and Two 12"H Drawers

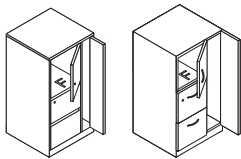

18"	18 ⁷ / ₈ "	24"	47 ¹ / ₂ "	RDD182448RA _	\$2700	\$3135	\$3536	\$3741	\$3741	Tower package 1	Tower package 1	Tower package 2	Tower package 2
23 ¹ / ₈ "	24"	24"	47 ¹ / ₂ "	RDD242448RA _	\$3253	\$3410	\$3826	\$4031	\$4031	Not required	Tower package 1	Not required	Tower package 1

One Fixed Shelf, Two 6"H Drawers, and One 12"H Drawer

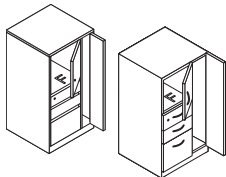

18"	18 ⁷ / ₈ "	24"	47 ¹ / ₂ "	RDD182448RB _	\$2940	\$3387	\$3797	\$4002	\$4002	Tower package 1	Tower package 1	Tower package 2	Tower package 2
23 ¹ / ₈ "	24"	24"	47 ¹ / ₂ "	RDD242448RB _	\$3482	\$3652	\$4094	\$4299	\$4299	Not required	Tower package 1	Not required	Tower package 1

One Fixed Shelf, One Adjustable Shelf, and Two 12"H Drawers

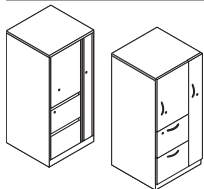

18"	18 ⁷ / ₈ "	24"	52"	RDD18244RA _	\$2985	\$3391	\$3785	\$3990	\$3990	Tower package 1	Tower package 1	Tower package 1	Tower package 1
23 ¹ / ₈ "	24"	24"	52"	RDD24244RA _	\$3515	\$3704	\$4048	\$4253	\$4253	Not required	Not required	Not required	Not required

► **Specification Information, continued on next page**



For Canadian Pricing

Multiply U.S. Price by the Canadian price factor.

► See page 1 for details.

► Specification Information, continued from previous page

Specification Information													
Dimensions			Style Number	U.S. Base Prices					Counterweights				
D	W	H		Flush Steel Front	Proud Steel Front	Proud Lam Front	Proud Comp Ven Front	Proud Wood Front	Steel Fronts		Lam/Comp Ven or Wood Fronts		
Flush Steel Front	Proud Steel/Lam/Comp Ven/Wood Front								Universal 3" Base	FrameOne Foot and c:scape Glide Bases	Universal 3" Base	FrameOne Foot and c:scape Glide Bases	
			Suffix F	Suffix P	Suffix L	Suffix W	Suffix W						

Tower with Doors Hinged on Right, continued

One Fixed Shelf, One Adjustable Shelf, Two 6"H Drawers, and One 12"H Drawer

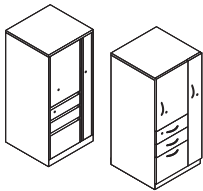

18"	18 ⁷ / ₈ "	24"	52"	RDD18244RB__	\$3181	\$3493	\$3982	\$4187	\$4187	Tower package 1	Tower package 1	Tower package 1	Tower package 1
23 ¹ / ₈ "	24"	24"	52"	RDD24244RB__	\$3710	\$3793	\$4293	\$4498	\$4498	Not required	Not required	Not required	Not required

One Fixed Shelf, Two Adjustable Shelves, and Two 12"H Drawers

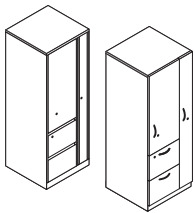

18"	18 ⁷ / ₈ "	24"	65 ¹ / ₂ "	RDD18245RC__	\$3349	\$3816	\$4204	\$4409	\$4409	Tower package 1	Tower package 1	Tower package 1	Tower package 1
23 ¹ / ₈ "	24"	24"	65 ¹ / ₂ "	RDD24245RC__	\$3710	\$3842	\$4580	\$4785	\$4785	Not required	Not required	Not required	Not required

One Fixed Shelf, Two Adjustable Shelves, Two 6"H Drawers, and One 12"H Drawer

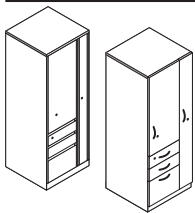

18"	18 ⁷ / ₈ "	24"	65 ¹ / ₂ "	RDD18245RD__	\$3544	\$3988	\$4400	\$4605	\$4605	Tower package 1	Tower package 1	Tower package 1	Tower package 1
23 ¹ / ₈ "	24"	24"	65 ¹ / ₂ "	RDD24245RD__	\$3906	\$4036	\$4781	\$4986	\$4986	Not required	Not required	Not required	Not required

 **For Canadian Pricing**
 Multiply U.S. Price by the Canadian price factor.
 ► See page 1 for details.



Specifying High-Density Storage Products

High-Density Storage Products	640
High-Density Storage Products Value Package	644
High-Density Storage Products Accessories	646

High-Density Storage

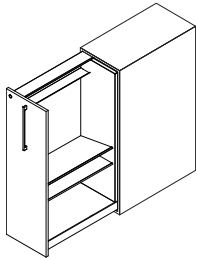

Drawing shows left-hand application, right-hand application is also available.

Standard Includes		Required to Specify
<ul style="list-style-type: none"> ▶ Need help? Product details, page 310 	<ul style="list-style-type: none"> • Case: laminate price group 1 • Drawer front: laminate to match case • Case interior: paint • Mirror • Nile pull: metal • Lock, keyed random: 9201 Polished Chrome • Four adjustable leveling glides • Vertical grain direction • Shelf, if 12"W is selected 	<ol style="list-style-type: none"> 1 Style number 2 Case width (see below under Required Selections) 3 Case depth (see below under Required Selections) 4 Case height (see below under Required Selections) 5 Handedness (see below under Required Selections) 6 Interior configuration (see below under Required Selections) 7 Laminate color number for case and drawer front 8 Paint color number for case interior 9 Pull (see below under Required Selections) 10 Metal color number for pulls 11 Options, if selected (see below) <p>▶ See <i>Surface Materials</i>, page 668.</p>

Required Selections	U.S. Price	Required to Specify
Case Width <ul style="list-style-type: none"> • 12"W • 15"W 	Prices at right Prices at right	Specify with 12" width. Specify with 15" width.
Case Depth <ul style="list-style-type: none"> • 24"D • 30"D 	Prices at right Prices at right	Specify with 24" depth. Specify with 30" depth.
Case Height <ul style="list-style-type: none"> • 42"H • 48"H 	No cost +\$255	Specify with 42" height. Specify with 48" height.
Handedness <ul style="list-style-type: none"> • Left hand • Right hand 	No cost No cost	Specify left-hand. Specify right-hand.
Interior Configuration <ul style="list-style-type: none"> • 12"W storage • Shelf 	\$ 146 Included in U.S. Base Price	Specify with shelf.
<ul style="list-style-type: none"> • 15"W storage • Bag drop • Shelf 	No cost +\$146	Specify with bag drop. Specify with shelf.

Tip: Shelf comes standard with 12"W storage. Bag drop is not available on 12"W storage.

Tip: Nile pull will default as the standard pull, you must confirm this selection or specify an optional pull.

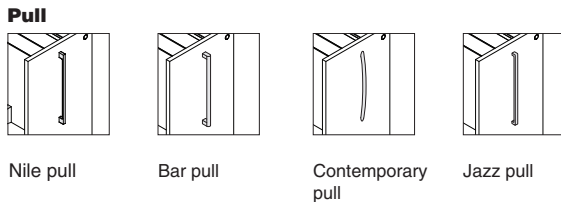

Nile pull Bar pull Contemporary pull Jazz pull

Options	U.S. Price	Required to Specify
Front Color Scheme <ul style="list-style-type: none"> • Non contrasting • Contrasting 	No cost +\$ 64	Specify with non contrasting. Specify with contrasting.
Surface Materials <ul style="list-style-type: none"> • Laminate on case • Laminate price group 2 • Laminate price group 3 • Open Line laminate 	See information at left See information at left +\$102 plus cost of laminate	Specify laminate color number. Specify laminate color number. ▶ See <i>Surface Material Reference Manual</i> .
<ul style="list-style-type: none"> • Laminate on contrasting case front • Laminate price group 2 on case front • Laminate price group 3 on case front • Open Line laminate on case front 	See information at left See information at left +\$102 plus cost of laminate	Specify laminate color number. Specify laminate color number. ▶ See <i>Surface Material Reference Manual</i> .

For laminate price group 2 and 3 pricing, please refer to the electronic catalog or SmartTools.



For Canadian Pricing
 Multiply U.S. Price by the Canadian price factor.
 ▶ See page 1 for details.

▶ Options, continued on next page

► Options, continued from previous page

Options	U.S. Price	Required to Specify	
Surface Materials, continued	Composite veneer for non-contrasting color scheme		
	• Composite veneer group 1	+\$1742	Specify with <i>composite veneer</i> and indicate composite veneer color number.
	• Composite veneer group 2	+\$2171	Specify with <i>composite veneer</i> and indicate composite veneer color number.
	Wood veneer for non-contrasting color scheme		
	• Wood group 1	+\$1742	Specify with <i>wood veneer</i> and indicate wood color number.
	• Wood group 2	+\$2171	Specify with <i>wood veneer</i> and indicate wood color number.
	• Wood group 3	+\$3236	Specify with <i>wood veneer</i> and indicate wood color number.
	• Customiz stain	No cost	Specify with <i>Customiz stain</i> .
	Composite veneer for contrasting color scheme		
	• For case front		
	–Composite group 1	+\$ 349	Specify with <i>composite veneer</i> and indicate composite veneer color number.
	–Composite group 2	+\$ 434	Specify with <i>composite veneer</i> and indicate composite veneer color number.
	• For case		
	–Composite group 1	+\$1395	Specify with <i>composite veneer</i> and indicate composite veneer color number.
	–Composite group 2	+\$1738	Specify with <i>composite veneer</i> and indicate composite veneer color number.
Wood veneer for contrasting color scheme			
• For case front			
–Wood group 1	+\$ 349	Specify with <i>wood veneer</i> and indicate wood color number.	
–Wood group 2	+\$ 434	Specify with <i>wood veneer</i> and indicate wood color number.	
–Wood group 3	+\$ 653	Specify with <i>wood veneer</i> and indicate wood color number.	
–Customiz stain	No cost	Specify with <i>Customiz stain</i> .	
• For case			
–Wood group 1	+\$1395	Specify with <i>wood veneer</i> and indicate wood color number.	
–Wood group 2	+\$1738	Specify with <i>wood veneer</i> and indicate wood color number.	
–Wood group 3	+\$2585	Specify with <i>wood veneer</i> and indicate wood color number.	
–Customiz stain	No cost	Specify with <i>Customiz stain</i> .	
Paint for case interior			
• Paint price group 1	No cost	Specify paint color number.	
• Paint price group 2	+\$ 87	Specify paint color number.	
• Paint price group 3	+\$ 227	Specify paint color number.	
Pull	Laminate or wood fronts		
	• Nile	No cost	Specify with <i>nile pull</i> .
	• Bar	No cost	Specify with <i>bar pull</i> .
	• Contemporary	–\$ 36	Specify with <i>contemporary pull</i> .
	• Jazz	–\$ 12	Specify with <i>jazz pull</i> .
Light	• Light	+\$ 305	Specify with <i>light</i> .
Coat Closet	• Coat closet	+\$ 74	Specify with <i>coat closet</i> .
Grain Direction	• Horizontal	No cost	Specify with <i>horizontal grain direction</i> .

Tip: Contrasting fronts and horizontal grain direction are available options for laminate front/laminate case, veneer front/laminate case, or laminate front/veneer case.

Tip: Light is available with bag drop configuration only.

► Options, continued on next page

 **For Canadian Pricing**
 Multiply U.S. Price by the Canadian price factor.
 ► See page 1 for details.

High-Density Storage, continued

► Options, continued from previous page

Tip: Magnetic boards are not available on 12"W storage.

Options		U.S. Price		Required to Specify
Magnetic Board	One magnetic board	42"H	48"H	Specify Cogent: Connect fabric number. Specify Billiard Multi-Use by Designtex fabric number.
	• Fabric price group 2	+\$173	+\$218	
	• Fabric price group 3	+\$218	+\$263	
	Two magnetic boards	42"H	48"H	Specify Cogent: Connect fabric number. Specify Billiard Multi-Use by Designtex fabric number.
	• Fabric price group 2	+\$347	+\$436	
	• Fabric price group 3	+\$436	+\$525	
Lock and Keying	Lock			Specify with 9250 Ember Chrome lock.
	• Ember Chrome	No cost		
	Keying			► Page 686
	• Factory and field-installed keying			
Related Products	• Worksurface support bracket			► Page 646
	• Panel connector bracket			► Page 646

Specification Information

Style Number	Width	U.S. Base Prices	
		24"D	30"D
HDSTG	12"	\$3827	\$4182
	15"	\$4078	\$4433

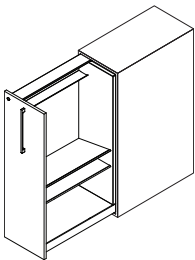

For Canadian Pricing

Multiply U.S. Price by the Canadian price factor.

► See page 1 for details.

High-Density Storage—Value Package

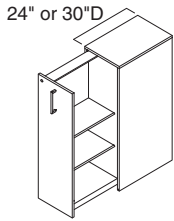

Drawing shows left-hand application, right-hand application is also available.

Tip: The high-density value package is a simplified version of high-density storage that includes two fixed shelves to solve organizational needs at a lower price point.

Tip: Nile pull will default as the standard pull, you must confirm this selection or specify an optional pull.

Standard Includes		Required to Specify
<ul style="list-style-type: none"> ▶ Need help? Product details, page 312 	<ul style="list-style-type: none"> • Case: laminate price group 1 • Drawer front: laminate to match case • Case interior: paint • Two fixed shelves: 7360 Merle • Nile pull: metal • Lock, keyed random: 9201 Polished Chrome • Four adjustable leveling glides • Vertical grain direction 	<ol style="list-style-type: none"> 1 Style number 2 Case width (see below under Required Selections) 3 Case depth (see below under Required Selections) 4 Case height (see below under Required Selections) 5 Handedness (see below under Required Selections) 6 Laminate color number for case and drawer front 7 Paint color number for case interior 8 Pull (see below under Required Selections) 9 Metal color number for pulls 10 Options, if selected (see below) <ul style="list-style-type: none"> ▶ See <i>Surface Materials</i>, page 668.

Required Selections	U.S. Price	Required to Specify
Case Width <ul style="list-style-type: none"> • 12"W • 15"W 	Prices at right Prices at right	Specify with 12" width. Specify with 15" width.
Case Depth <ul style="list-style-type: none"> • 24"D • 30"D 	Prices at right Prices at right	Specify with 24" depth. Specify with 30" depth.
Case Height <ul style="list-style-type: none"> • 42"H • 48"H 	No cost +\$255	Specify with 42" height. Specify with 48" height.
Handedness <ul style="list-style-type: none"> • Left hand • Right hand 	No cost No cost	Specify left-hand. Specify right-hand.

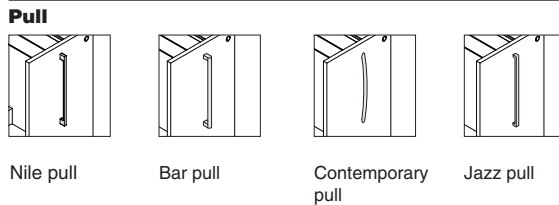

Options	U.S. Price	Required to Specify
Front Color Scheme <ul style="list-style-type: none"> • Non contrasting • Contrasting 	No cost +\$ 64	Specify with non contrasting. Specify with contrasting.
Surface Materials <p>Laminate on case</p> <ul style="list-style-type: none"> • Laminate price group 2 • Laminate price group 3 • Open Line laminate <p>Laminate on contrasting case front</p> <ul style="list-style-type: none"> • Laminate price group 2 on case front • Laminate price group 3 on case front • Open Line laminate on case front <p>Paint for case interior</p> <ul style="list-style-type: none"> • Paint price group 1 • Paint price group 2 • Paint price group 3 	See information at left See information at left +\$102 plus cost of laminate	Specify laminate color number. Specify laminate color number. ▶ See <i>Surface Material Reference Manual</i> .
	See information at left See information at left +\$102 plus cost of laminate	Specify laminate color number. Specify laminate color number. ▶ See <i>Surface Material Reference Manual</i> .
	No cost +\$ 87 +\$227	Specify paint color number. Specify paint color number. Specify paint color number.

For laminate price group 2 and 3 pricing, please refer to the electronic catalog or SmartTools.

 **For Canadian Pricing**
Multiply U.S. Price by the Canadian price factor.
▶ See page 1 for details.

▶ Options, continued on next page

► Options, continued from previous page

Options	U.S. Price	Required to Specify
Pull	Laminate fronts	
	• Nile	No cost Specify with <i>nile pull</i> .
	• Bar	No cost Specify with <i>bar pull</i> .
	• Contemporary	-\$36 Specify with <i>contemporary pull</i> .
	• Jazz	-\$12 Specify with <i>jazz pull</i> .
Coat Closet	• Coat closet	+\$74 Specify with <i>coat closet</i> .
Grain Direction	• Horizontal	No cost Specify with <i>horizontal grain direction</i> .
Lock and Keying	Lock	
	• Ember Chrome	No cost Specify with <i>9250 Ember Chrome lock</i> .
	Keying	
	• Factory and field-installed keying	► Page 686
Related Products	• Worksurface support bracket	► Page 646
	• Panel connector bracket	► Page 646

Specification Information

Style Number	Dimensions W	U.S. Base Prices	
		24"D	30"D
HDSTGV	12"	\$2833	\$3188
	15"	\$3084	\$3439

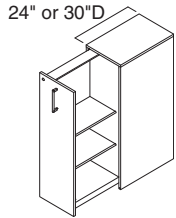

 **For Canadian Pricing**
Multiply U.S. Price by the
Canadian price factor.
► See page 1 for details.

High-Density Storage Accessories

Worksurface Support Bracket

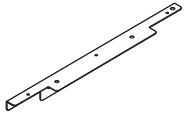

Standard Includes		Required to Specify
<ul style="list-style-type: none"> ▶ Need help? Product details, page 310 	<ul style="list-style-type: none"> • Bracket: paint • Attachment hardware 	<ol style="list-style-type: none"> 1 Style number 2 Depth (see below under Required Selections) 3 Paint color number for bracket <ul style="list-style-type: none"> ▶ See <i>Surface Materials</i>, page 668.

	Required Selections	U.S. Price	Required to Specify
Depth	<ul style="list-style-type: none"> • 24"D • 30"D 	No cost No cost	Specify with 24"D bracket. Specify with 30"D bracket.
Related Products	<ul style="list-style-type: none"> • High-density storage 		▶ Pages 640 and 644

Specification Information	
Style Number	U.S. Price
HDWS	\$167

Panel Connector Bracket



Standard Includes		Required to Specify
<ul style="list-style-type: none"> ▶ Need help? Product details, page 310 	<ul style="list-style-type: none"> • Connector bracket 	<ol style="list-style-type: none"> 1 Style number 2 Handedness (see below under Required Selections)

	Required Selections	U.S. Price	Required to Specify
Handedness	<ul style="list-style-type: none"> • Left hand • Right hand 	No cost No cost	Specify left hand. Specify right hand.
Related Products	<ul style="list-style-type: none"> • High-density storage 		▶ Pages 640 and 644

Specification Information		
Style Number	Dimensions H	U.S. Price
HDPNLCNT	39 ⁵ / ₈ "	\$122



For Canadian Pricing
 Multiply U.S. Price by the Canadian price factor.
 ▶ See page 1 for details.

Specifying Storage Tops, Shelves, and Accessories

Connectors	648
Steel Security Tops	650
Square Edge Tops	652
Adjustable Shelves for Towers	654
Steel Storage Accessories	655

Connectors

Worksurface-to-Tower Connectors



Tip: For use with universal steel storage only.

Standard Includes	Required to Specify
<ul style="list-style-type: none"> ▶ Need help? Product details, page 305 • Connector: paint • Attachment hardware 	<ul style="list-style-type: none"> 1 Style number 2 Paint color number for connector ▶ See <i>Surface Materials</i>, page 668.

Specification Information		
• Dimensions	• Style	• U.S.
: D	: Number	: Price
24"	UFSTOWER24	\$182
30"	UFSTOWER30	\$182
:	:	:



For Canadian Pricing
 Multiply U.S. Price by the Canadian price factor.
 ▶ See page 1 for details.

Storage-to-Panel Connectors

Tip: Storage-to-panel connectors can only be used with universal steel storage products manufactured on or after October 2005.

Tip: For use with universal steel storage only.

Standard Includes	Required to Specify
-------------------	---------------------

▶ Need help? Product details, page 306

- Connector: black paint
- Attachment hardware

Style number

Specification Information		
Dimensions	Style	U.S.
H	Number	Price

Low Storage-to-Panel Connectors for One-High Storage

Left-Hand

8¾"	UFSLOWLHANS	\$133
-----	--------------------	-------

Right-Hand

8¾"	UFSLOWRHANS	\$133
-----	--------------------	-------

Medium Storage-to-Panel Connectors for 1.5-High, 2-High, and 3-High Storage

Left-Hand

16"	UFSMEDLHANS	\$133
-----	--------------------	-------

Right-Hand

16"	UFSMEDRHANS	\$133
-----	--------------------	-------

Tall Storage-to-Panel Connectors for 48"H, 4-High, and 5-High Towers

Left-Hand

39⅝"	UFSTALLHANS	\$133
------	--------------------	-------

Right-Hand

39⅝"	UFSTALLRHANS	\$133
------	---------------------	-------



 **For Canadian Pricing**
 Multiply U.S. Price by the Canadian price factor.
 ▶ See page 1 for details.

Steel Security Tops

For Use with Flush or Proud Front Products

Tip: Tops are for field installation only.

*Tip: Security tops should only be used on units that are positioned under a work-surface—these are **NOT** structural tops.*

Tip: Security top cannot be installed on a file with a lift-up door in the top position.

Tip: For use with universal steel storage only.

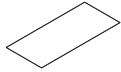
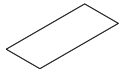

Standard Includes		Required to Specify
▶ Need help? Product details, page 302	<ul style="list-style-type: none"> • Security top: all paint price groups • Attachment hardware 	1 Style number 2 Paint color number for top ▶ See <i>Surface Materials</i> , page 668.

Specification Information

Dimensions		For Use On	Style Number	U.S. Price
D	W			

Flush Front

18"	30"	Lateral file, storage cabinet	RATF1830F	\$155
18"	36"	Lateral file, storage cabinet	RATF1836F	\$155
18"	42"	Lateral file, storage cabinet	RATF1842F	\$155
23½"	30"	Lateral file, storage cabinet	RATF2430F	\$155
23½"	36"	Lateral file, storage cabinet	RATF2436F	\$155

Proud Front

18⅞"	30"	Lateral file, storage cabinet	RATF1830P	\$155
18⅞"	36"	Lateral file, storage cabinet	RATF1836P	\$155
18⅞"	42"	Lateral file, storage cabinet	RATF1842P	\$155
24"	30"	Lateral file, storage cabinet	RATF2430P	\$155
24"	36"	Lateral file, storage cabinet	RATF2436P	\$155



For Canadian Pricing

Multiply U.S. Price by the Canadian price factor.

▶ See page 1 for details.

Square Edge Tops

For Use with Flush and Proud Front Products

Standard Includes		Required to Specify
<ul style="list-style-type: none"> ▶ Need help? See <i>Storage Specification Guide</i>. 	<ul style="list-style-type: none"> • 1³/₁₆"H top with square edge profile on all sides: laminate price group 1 or wood group 1 • Attachment hardware 	<ol style="list-style-type: none"> 1 Style number with appropriate front style suffix in the space provided <ul style="list-style-type: none"> F Flush steel front P Proud steel or proud wood front 2 Laminate or wood color number for top 3 Plastic color number for 1 mm edges of laminate top 4 Options, if selected (see below) <p>▶ See <i>Surface Materials</i>, page 668.</p>

Tip: For use with universal steel storage only.

For wood group 2, wood group 3, laminate price group 2, and laminate price group 3 pricing, please refer to the electronic catalog or SmartTools.

Options	U.S. Price	Required to Specify
Surface Materials <ul style="list-style-type: none"> • Laminate top <ul style="list-style-type: none"> • Laminate price group 2 • Laminate price group 3 • Open Line laminate • Wood veneer top <ul style="list-style-type: none"> • Wood group 2 • Wood group 3 • Customiz stain on wood veneer top • Full-fill finish on wood group 1 veneer 	See information at left See information at left +\$102 plus cost of laminate See information at left See information at left No cost Prices at right	Specify laminate color number. Specify laminate color number. ▶ See <i>Surface Materials Reference Manual</i> . Specify wood color number. Specify wood color number. Specify <i>with Customiz stain</i> . ▶ See <i>Surface Materials Reference Manual</i> . Specify <i>with full-fill finish</i> and select wood color number. ▶ See <i>Surface Materials Reference Manual</i> .

Specification Information						
Dimensions		Style		U.S. Base Prices		Option
D	W	H	Number	Flush Steel Front	Proud Steel or Proud Wood Front	(Add \$ to Base Price)
Flush Steel Front	Proud Steel/ Proud Wood			Suffix F	Suffix P	Full-Fill Finish on Wood Group 1

Tip: Your specification is not complete until you add a suffix to the style number to define the front style (for example, RATL1524 becomes RATL1524F for a top to be used on a flush steel front unit).

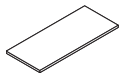

Individual File Laminate Tops

18"	18 ⁷ / ₈ "	30"	1 ³ / ₁₆ "	RATL1830__	\$ 294	\$ 294	N.A.
18"	18 ⁷ / ₈ "	36"	1 ³ / ₁₆ "	RATL1836__	\$ 318	\$ 318	N.A.
18"	18 ⁷ / ₈ "	42"	1 ³ / ₁₆ "	RATL1842__	\$ 344	\$ 344	N.A.
23 ¹ / ₈ "	24"	30"	1 ³ / ₁₆ "	RATL2430__	\$ 325	\$ 325	N.A.
23 ¹ / ₈ "	24"	36"	1 ³ / ₁₆ "	RATL2436__	\$ 344	\$ 344	N.A.

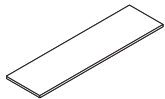

Laminate Common Tops

18"	18 ⁷ / ₈ "	60 ¹ / ₁₆ "	1 ³ / ₁₆ "	RATCL1860__	\$ 476	\$ 476	N.A.
18"	18 ⁷ / ₈ "	66 ¹ / ₁₆ "	1 ³ / ₁₆ "	RATCL1866__	\$ 552	\$ 552	N.A.
18"	18 ⁷ / ₈ "	72 ¹ / ₁₆ "	1 ³ / ₁₆ "	RATCL1872__	\$ 619	\$ 619	N.A.
18"	18 ⁷ / ₈ "	78 ¹ / ₁₆ "	1 ³ / ₁₆ "	RATCL1878__	\$ 787	\$ 787	N.A.
18"	18 ⁷ / ₈ "	84 ¹ / ₁₆ "	1 ³ / ₁₆ "	RATCL1884__	\$ 888	\$ 888	N.A.
18"	18 ⁷ / ₈ "	90 ¹ / ₈ "	1 ³ / ₁₆ "	RATCL1890__	\$ 989	\$ 989	N.A.
18"	18 ⁷ / ₈ "	96 ¹ / ₈ "	1 ³ / ₁₆ "	RATCL1896__	\$1089	\$1089	N.A.
18"	18 ⁷ / ₈ "	108 ¹ / ₈ "	1 ³ / ₁₆ "	RATCL18108__	\$1310	\$1310	N.A.



For Canadian Pricing
Multiply U.S. Price by the Canadian price factor.

▶ See page 1 for details.

▶ **Specification Information, continued on next page**

► Specification Information, continued from previous page

Tip: Your specification is not complete until you add a suffix to the style number to define the front style (for example, RATL1524_ becomes RATL1524F for a top to be used on a flush steel front unit).

Specification Information							
Dimensions				Style Number	U.S. Base Prices		Option (Add \$ to Base Price)
D	W	H	Flush Steel Front		Proud Steel/Wood	Proud Steel or Proud Wood Front	

Laminate Common Tops, continued

23 ¹ / ₈ "	24"	60 ¹ / ₁₆ "	1 ³ / ₁₆ "	RATCL2460 _	\$ 502	\$ 502	N.A.
23 ¹ / ₈ "	24"	66 ¹ / ₁₆ "	1 ³ / ₁₆ "	RATCL2466 _	\$ 561	\$ 561	N.A.
23 ¹ / ₈ "	24"	72 ¹ / ₁₆ "	1 ³ / ₁₆ "	RATCL2472 _	\$ 633	\$ 633	N.A.
23 ¹ / ₈ "	24"	90 ¹ / ₈ "	1 ³ / ₁₆ "	RATCL2490 _	\$1061	\$1061	N.A.
23 ¹ / ₈ "	24"	96 ¹ / ₈ "	1 ³ / ₁₆ "	RATCL2496 _	\$1165	\$1165	N.A.
23 ¹ / ₈ "	24"	108 ¹ / ₈ "	1 ³ / ₁₆ "	RATCL24108 _	\$1406	\$1406	N.A.
36 ¹ / ₁₆ "	37 ¹³ / ₁₆ "	36"	1 ³ / ₁₆ "	RATCL3636 _	\$ 604	\$ 604	N.A.
36 ¹ / ₁₆ "	37 ¹³ / ₁₆ "	72 ¹ / ₁₆ "	1 ³ / ₁₆ "	RATCL3672 _	\$ 832	\$ 832	N.A.
46 ⁵ / ₁₆ "	48 ¹ / ₁₆ "	36"	1 ³ / ₁₆ "	RATCL4836 _	\$ 681	\$ 681	N.A.
46 ⁵ / ₁₆ "	48 ¹ / ₁₆ "	72 ¹ / ₁₆ "	1 ³ / ₁₆ "	RATCL4872 _	\$ 933	\$ 933	N.A.

Individual File Wood Tops

18"	18 ⁷ / ₈ "	30"	1 ³ / ₁₆ "	RATW1830 _	\$ 760	\$ 760	+\$102
18"	18 ⁷ / ₈ "	36"	1 ³ / ₁₆ "	RATW1836 _	\$ 776	\$ 776	+\$102
18"	18 ⁷ / ₈ "	42"	1 ³ / ₁₆ "	RATW1842 _	\$ 875	\$ 875	+\$102
23 ¹ / ₈ "	24"	30"	1 ³ / ₁₆ "	RATW2430 _	\$ 788	\$ 788	+\$102
23 ¹ / ₈ "	24"	36"	1 ³ / ₁₆ "	RATW2436 _	\$ 809	\$ 809	+\$102

Wood Common Tops

18"	18 ⁷ / ₈ "	60 ¹ / ₁₆ "	1 ³ / ₁₆ "	RATCW1860 _	\$1071	\$1071	+\$102
18"	18 ⁷ / ₈ "	66 ¹ / ₁₆ "	1 ³ / ₁₆ "	RATCW1866 _	\$1127	\$1127	+\$102
18"	18 ⁷ / ₈ "	72 ¹ / ₁₆ "	1 ³ / ₁₆ "	RATCW1872 _	\$1188	\$1188	+\$102
18"	18 ⁷ / ₈ "	78 ¹ / ₁₆ "	1 ³ / ₁₆ "	RATCW1878 _	\$1418	\$1418	+\$102
18"	18 ⁷ / ₈ "	84 ¹ / ₁₆ "	1 ³ / ₁₆ "	RATCW1884 _	\$1613	\$1613	+\$102
18"	18 ⁷ / ₈ "	90 ¹ / ₈ "	1 ³ / ₁₆ "	RATCW1890 _	\$1704	\$1704	+\$102
18"	18 ⁷ / ₈ "	96 ¹ / ₈ "	1 ³ / ₁₆ "	RATCW1896 _	\$1878	\$1878	+\$102
23 ¹ / ₈ "	24"	60 ¹ / ₁₆ "	1 ³ / ₁₆ "	RATCW2460 _	\$1100	\$1100	+\$102
23 ¹ / ₈ "	24"	66 ¹ / ₁₆ "	1 ³ / ₁₆ "	RATCW2466 _	\$1154	\$1154	+\$102
23 ¹ / ₈ "	24"	72 ¹ / ₁₆ "	1 ³ / ₁₆ "	RATCW2472 _	\$1227	\$1227	+\$102
23 ¹ / ₈ "	24"	90 ¹ / ₈ "	1 ³ / ₁₆ "	RATCW2490 _	\$1822	\$1822	+\$102
23 ¹ / ₈ "	24"	96 ¹ / ₈ "	1 ³ / ₁₆ "	RATCW2496 _	\$2009	\$2009	+\$102

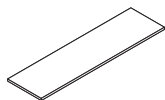
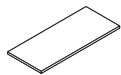
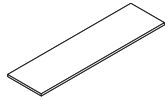

 **For Canadian Pricing**
Multiply U.S. Price by the Canadian price factor.
► See page 1 for details.

Adjustable Shelves for Towers

Adjustable Steel Standard Shelves

For Use with Towers



Tip: Adjustable shelves are for field installation only.

Standard Includes	Required to Specify
<ul style="list-style-type: none"> ▶ Need help? See <i>Storage Specification Guide</i>. • ¾"H adjustable shelf: all paint price groups • Set of adjustable brackets: black only 	<ul style="list-style-type: none"> 1 Style number 2 Paint color number for shelf ▶ See <i>Surface Materials</i>, page 668.

Specification Information

Dimensions		Style	U.S.
D	W	Number	Price

For Use with Open Side Towers

24"	15"	RXSA2415	\$88
30"	15"	RXSA3015	\$95

For Use with Dual Door Towers

24"	15"	RXSAFFT2415	\$88

Adjustable Glass Shelves

For Use with Open Side Towers Only



Tip: Adjustable shelves are for field installation only.

Standard Includes	Required to Specify
<ul style="list-style-type: none"> ▶ Need help? See <i>Storage Specification Guide</i>. • ¾"H adjustable shelf: frosted glass only • Set of four adjustable brackets: black only 	<ul style="list-style-type: none"> Style number

Specification Information

Dimensions		Style	U.S.
D	W	Number	Price

24"	15"	RXSG2415	\$218
30"	15"	RXSG3015	\$243



For Canadian Pricing

Multiply U.S. Price by the Canadian price factor.

▶ See page 1 for details.

Steel Storage Accessories

Rails

For Use in Pedestals Manufactured after February 22, 2004
 For Use in Universal Towers

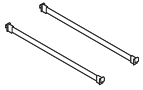

Tip: Two rails per drawer accommodate side-to-side filing of letter-, A4-, and legal-size hanging folders. Exception: Legal-size file folders cannot be filed in 18"D pedestals.

Tip: For pedestals manufactured on or before February 22, 2004, see Service Parts catalog.

Standard Includes	Required to Specify
<ul style="list-style-type: none"> ▶ Need help? See <i>Storage Specification Guide</i>. • Package of two rails: black only 	Style number

Specification Information		
Width	Style Number	U.S. Price
12"	RXADRL15	\$37

Storage Accessories

Dividers

For Use in Pedestals Manufactured after February 22, 2004
 For Use in Universal Towers

Tip: For pedestals manufactured on or before February 22, 2004, see Service Parts catalog.

Standard Includes	Required to Specify
<ul style="list-style-type: none"> ▶ Need help? See <i>Storage Specification Guide</i>. • Package of dividers: black only 	Style number

Specification Information			
Width	Quantity	Style Number	U.S. Price

For Use in 6"H Drawers

12"	2	RDV1506	\$ 59
-----	---	----------------	-------

For Use in 12"H Drawers

12"	2	RDV1512	\$ 63
12"	10	RDV151210	\$296



For Canadian Pricing
 Multiply U.S. Price by the Canadian price factor.
 ▶ See page 1 for details.

Steel Storage Accessories, continued

Pencil Tray

For Use in Pedestals and Universal Towers

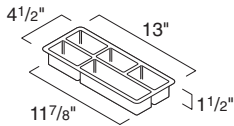

Tip: Pedestals with box drawers include one pencil tray per pedestal.

Standard Includes	Required to Specify
-------------------	---------------------

- | | | |
|--------------------------------------------------------------------------------------------------------|-----------------------------------------------------------------------------|--------------|
| <ul style="list-style-type: none"> ▶ Need help? See <i>Storage Specification Guide</i>. | <ul style="list-style-type: none"> • Pencil tray: black only | Style number |
|--------------------------------------------------------------------------------------------------------|-----------------------------------------------------------------------------|--------------|

Specification Information

Style Number	U.S. Price
RPXDPT	\$51

Reference Shelf

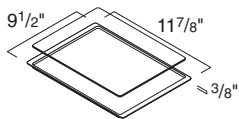

Standard Includes	Required to Specify
-------------------	---------------------

- | | | |
|--------------------------------------------------------------------------------------------------------|-----------------------------------------------------------------------------------------------------------------------|--------------|
| <ul style="list-style-type: none"> ▶ Need help? See <i>Storage Specification Guide</i>. | <ul style="list-style-type: none"> • Reference shelf: black only • Insert: clear plastic only | Style number |
|--------------------------------------------------------------------------------------------------------|-----------------------------------------------------------------------------------------------------------------------|--------------|

Specification Information

Style Number	U.S. Price
RPXDRS	\$74

Hanging Folder Bars

For Use with Universal Lateral Files and Universal Combination Cabinets Manufactured on or after October 17, 2005

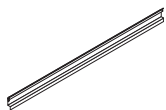

Standard Includes	Required to Specify
-------------------	---------------------

- | | | |
|--------------------------------------------------------------------------------------------------------|------------------------------------------------------------------------------------|--------------|
| <ul style="list-style-type: none"> ▶ Need help? See <i>Storage Specification Guide</i>. | <ul style="list-style-type: none"> • Hanging folder bar: black only | Style number |
|--------------------------------------------------------------------------------------------------------|------------------------------------------------------------------------------------|--------------|

Specification Information

Width	Style Number	U.S. Price
30"	RAHF30	\$22
36"	RAHF36	\$22
42"	RAHF42	\$22



For Canadian Pricing
 Multiply U.S. Price by the Canadian price factor.
 ▶ See page 1 for details.

Rails

For Use with Lateral Files and Combination Cabinets

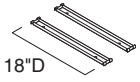

18"D

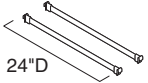

24"D

Tip: All drawer sizes require two rails per drawer for maximum capacity front-to-back filling.

Note: Actual rail dimensions are 15½" deep for an 18" deep cabinet and 20" deep for a 24" deep cabinet.

Standard Includes	Required to Specify
-------------------	---------------------

- | | | |
|----------------------------------------------------------|--------------------------------------------|--------------|
| ▶ Need help?
See <i>Storage Specification Guide</i> . | • Package of two or four rails: black only | Style number |
|----------------------------------------------------------|--------------------------------------------|--------------|

Specification Information

Depth	Style Number	U.S. Price
:	:	:

Package of Two

18"	800RW	\$51
24"	RXADRL24	\$37
:	:	:

Package of Four

24"	RXADRL2442	\$70
:	:	:

Dividers

For Use in Lateral Files and Combination Cabinets

Standard Includes	Required to Specify
-------------------	---------------------

- | | | |
|----------------------------------------------------------|----------------------------------------|--------------|
| ▶ Need help?
See <i>Storage Specification Guide</i> . | • Carton of three dividers: black only | Style number |
|----------------------------------------------------------|----------------------------------------|--------------|

Specification Information

Dimensions			Style Number	U.S. Price
D	W	H		
:	:	:	:	:

For Use in 12"H Drawers or 12"H Roll-Out Shelves

11 7/8"	1/16"	6 1/4"	800DV12	\$38
:	:	:	:	:

For Use in 6"H Roll-Out Shelves or Drawers and 9"H Drawers

13 1/2"	1/16"	3 5/8"	800DV6	\$38
:	:	:	:	:

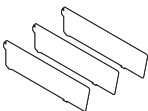

For Canadian Pricing

Multiply U.S. Price by the Canadian price factor.

▶ See page 1 for details.

Steel Storage Accessories, continued

Shelf Divider Assembly

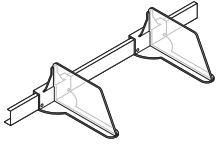

Standard Includes	Required to Specify
<ul style="list-style-type: none"> ▶ Need help? See <i>Storage Specification Guide</i>. • Divider bracket: black only • Two dividers: clear plastic 	Style number

Specification Information		
• Width	• Style Number	• U.S. Price
30"	RASTDIV30	\$145
36"	RASTDIV36	\$145
42"	RASTDIV42	\$145
:	:	:

Bookends

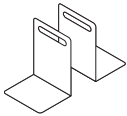

Standard Includes	Required to Specify
<ul style="list-style-type: none"> ▶ Need help? See <i>Storage Specification Guide</i>. • Package of two or twenty bookends: 6695 Midnight only 	Style number

Specification Information		
• Style Number	• Quantity	• U.S. Price
KDIV02	2	\$ 47
KDIV20	20	\$441
:	:	:



For Canadian Pricing
 Multiply U.S. Price by the Canadian price factor.
 ▶ See page 1 for details.

Wood Drawer Pulls

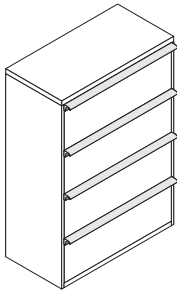

Standard Includes		Required to Specify
<ul style="list-style-type: none"> ▶ Need help? See <i>Storage Specification Guide</i>. 	<ul style="list-style-type: none"> • Pull: wood group 1 	<ul style="list-style-type: none"> 1 Style number 2 Wood color number 3 Options, if selected (see below) ▶ See <i>Surface Materials</i>, page 668.

Options	U.S. Price	Required to Specify
Surface Materials <ul style="list-style-type: none"> • Customiz stain 	No cost	<ul style="list-style-type: none"> Specify with <i>Customiz stain</i>. ▶ See <i>Surface Materials Reference Manual</i>.

Specification Information		
Width	Style Number	U.S. Price
15"	RPULL15W	\$245
30"	RPULL30W	\$335
36"	RPULL36W	\$379
42"	RPULL42W	\$425

Counterweight Packages

For Use with Universal One-High and 1.5-high Lateral Files

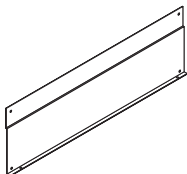

Standard Includes		Required to Specify
<ul style="list-style-type: none"> ▶ Need help? See <i>Storage Specification Guide</i>. 	<ul style="list-style-type: none"> • Counterweight: black only • Attachment hardware 	<ul style="list-style-type: none"> Style number

Specification Information		
Package Name	Style Number	U.S. Price
Package 30	RAACW30	\$329
Package 36	RAACW36	\$329
Package 42	RAACW42	\$329
Package D	RAACWD	\$180
Package E	RAACWE	\$235
Package F	RAACWF	\$329

 **For Canadian Pricing**
 Multiply U.S. Price by the Canadian price factor.
 ▶ See page 1 for details.

Steel Storage Accessories, continued

Counterweight Retro Kit

For Use with Universal One-High and Two Drawer Lateral Files

*Tip: Use this retrofit kit when ordering **RAACW30**, **RAACW36**, or **RAACW42**. For use on One-High or Two Drawer lateral files with feet that were manufactured prior to February 21, 2020.*

Standard Includes	Required to Specify
<ul style="list-style-type: none"> Counterweight retrofit kit 	Style number

Specification Information

Style Number	U.S. Price
RAACWR	\$74

Counterweight Packages

For Use with Universal 2H, 3H, 4H, and 5H Lateral Files, and Combination Cabinets

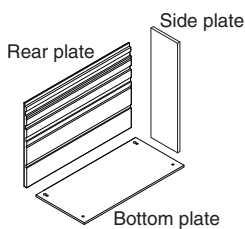

Standard Includes	Required to Specify
<ul style="list-style-type: none"> Need help? See <i>Storage Specification Guide</i>. Counterweight: black only Attachment hardware 	Style number

Specification Information

Package Number	Style Number	U.S. Price	Package Number	Style Number	U.S. Price
Package 1	RAACW1	\$180	Package 5	RAACW5	\$329
Package 2	RAACW2	\$180	Package 6	RAACW6	\$329
Package 3	RAACW3	\$180	Package 7	RAACW7	\$329
Package 4	RAACW4	\$235	Package 8	RAACW8	\$329

Counterweight Packages

For Use with Universal Towers

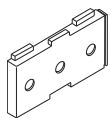

Tip: Tower packages 1 and 2 are for 18"D and 24"D units and tower package 3 is for 30"D units.

Standard Includes	Required to Specify
<ul style="list-style-type: none"> Need help? See <i>Storage Specification Guide</i>. Counterweight: black only Attachment hardware 	Style number

Specification Information

Package Name	Style Number	U.S. Price
Tower package 1	RAACT1	\$161
Tower package 2	RAACT2	\$198
Tower package 3	RAACT3	\$161

For Canadian Pricing
Multiply U.S. Price by the Canadian price factor.
▶ See page 1 for details.

Anchor Bracket Package for Products with Glides

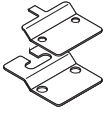

Tip: Four anchor bracket packages are required for each cabinet.

Standard Includes	Required to Specify
<ul style="list-style-type: none"> ▶ Need help? See <i>Storage Specification Guide</i>. • Two-piece anchor bracket and attachment hardware 	Style number

Specification Information	
Style Number	U.S. Price
RAANBRK	\$52

Underworksurface Lateral File Fillers

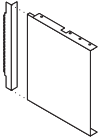

Tip: Order filler which matches nominal worksurface depth.

Tip: 24"D filler is used with 18"D storage. 30"D filler is used with 18"D or 24"D storage.

Tip: Fillers are for use with a Universal 3" base only.

Standard Includes	Required to Specify
<ul style="list-style-type: none"> ▶ Need help? See <i>Storage Specification Guide</i>. • Filler: paint 	<ul style="list-style-type: none"> 1 Style number 2 Paint color number for filler 3 Options, if selected (see below) ▶ See <i>Surface Materials</i>, page 668.

Options	U.S. Price	Required to Specify
Surface Materials	<ul style="list-style-type: none"> • Paint price group 1 • Paint price group 2 • Paint price group 3 	<ul style="list-style-type: none"> No cost +\$45 +\$74
		<ul style="list-style-type: none"> Specify paint color number. Specify paint color number. Specify paint color number.

Specification Information		
Depth	Style Number	U.S. Base Price

For Lateral Files with Flush Steel Fronts

24"	ULFF24F	\$81
30"	ULFF30F	\$81

For Lateral Files with Proud Fronts

24"	ULFF24P	\$81
30"	ULFF30P	\$81



For Canadian Pricing
Multiply U.S. Price by the Canadian price factor.
▶ See page 1 for details.

Steel Storage Accessories, continued

Attachment Cable



Tip: For use with underwork-surface lateral files.

Standard Includes	Required to Specify
<ul style="list-style-type: none"> • Attachment cable • Package of 1 or 25 	Style number

Specification Information

Style Number	U.S. Price
PAB12 (package of 1)	\$ 31
PAB12M (package of 25)	\$480



For Canadian Pricing

Multiply U.S. Price by the Canadian price factor.

▶ See page 1 for details.

Specifying Duo Storage Products

Duo Storage

664

Duo Storage

Duo Storage

For Use with Answer In-Line, L, T, and End-of-Run Junctions

Standard Includes		Required to Specify
<ul style="list-style-type: none"> ▶ Need help? Product details, page 318 	<ul style="list-style-type: none"> Tall storage box: laminate Painted steel interior divider cover: paint price group 1 Leg: 4799 Platinum paint Panel attachment brackets: 4799 Platinum paint Worksurface brackets 	<ul style="list-style-type: none"> 1 Style number 2 Laminate color number for box 3 Paint color number for interior 4 Options, if selected (see below) ▶ See <i>Surface Materials</i>, page 668.

Options	U.S. Price	Required to Specify
Surface Materials Interior divider cover <ul style="list-style-type: none"> Paint price group 1 Paint price group 2 Paint price group 3 	<ul style="list-style-type: none"> No cost +\$ 22 +\$ 36 	<ul style="list-style-type: none"> Specify paint color number. Specify paint color number. Specify paint color number.
<ul style="list-style-type: none"> Open Line laminate on box 	<ul style="list-style-type: none"> +\$102 plus cost of laminate 	<ul style="list-style-type: none"> ▶ See <i>Surface Materials Reference Manual</i>.

Specification Information					
Dimensions			Style	U.S.	
D	W	H	Number	Base	Price

Individual Tall Storage with Leg

18"	54"	15"	BDTS54ANL	\$1615
18"	66"	15"	BDTS66ANL	\$1808
18"	78"	15"	BDTS78ANL	\$2027

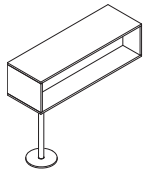

Tip: For individual tall storage, only the external side of the interior divider cover has the option to be painted.

Shared Tall Storage with Leg

18"	54"	15"	BDTD54ANL	\$1766
18"	66"	15"	BDTD66ANL	\$1954
18"	78"	15"	BDTD78ANL	\$2275

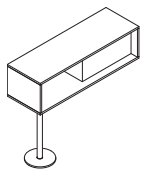

For Canadian Pricing

Multiply U.S. Price by the Canadian price factor.

▶ See page 1 for details.

Duo Storage

For Use with Top Cap Mounted Storage

Standard Includes		Required to Specify
<ul style="list-style-type: none"> ▶ Need help? Product details, page 318 	<ul style="list-style-type: none"> • Tall storage box: laminate • Painted steel interior divider cover on tall storage: paint price group 1 	<ul style="list-style-type: none"> 1 Style number 2 Paint color number for top cap 3 Paint color number for interior ▶ See <i>Surface Materials</i>, page 668.

Options	U.S. Price	Required to Specify
Surface Materials <ul style="list-style-type: none"> • Interior divider cover • Paint price group 1 • Paint price group 2 • Paint price group 3 	<ul style="list-style-type: none"> No cost +\$ 22 +\$ 36 	<ul style="list-style-type: none"> Specify paint color number. Specify paint color number. Specify paint color number.
<ul style="list-style-type: none"> • Open Line laminate on box 	<ul style="list-style-type: none"> +\$102 plus cost of laminate 	<ul style="list-style-type: none"> ▶ See <i>Surface Materials Reference Manual</i>.

Specification Information				
Dimensions			Style	U.S.
D	W	H	Number	Base Price

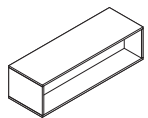

Individual Tall Storage

18"	54"	15"	BDTS54	\$1101
18"	66"	15"	BDTS66	\$1281
:	:	:	:	:

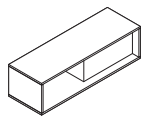

Shared Tall Storage

18"	54"	15"	BDTD54	\$1246
18"	66"	15"	BDTD66	\$1426
:	:	:	:	:

 **For Canadian Pricing**
 Multiply U.S. Price by the Canadian price factor.
 ▶ See page 1 for details.



Surface Materials

Surface Materials	668
Specification Guidelines for Directional Fabrics	674
Paint Color Availability Matrix	676
Recommended Worksurface Edge Finishes	678
Directional Laminate Grain Directions	680
Wood Veneer Grain Directions	682

Surface Materials

This listing includes all the surface material choices that are available for the products in this specification guide.

Resources

For more information about surface materials, refer to the following resources:

Additional surface materials specification tools are available to assist you in the specification process—the Surface Materials Binders.

The global surface materials palette is a core collection of finishes that is available across multiple geographies (Americas/ EMEA – Europe, Middle East, and Africa/ APAC – Asia Pacific) and on global product lines, where applicable. For a list of finishes included in the offering, see the Surface Materials Reference Manual. Additional details, like product approvals by geography and finish number conversions, can also be found in the Surface Materials Reference Manual or see steelcase.com/surface-materials under the Select Surface section.

Surface Materials Binders

- Surface Materials Reference Manual
- A complete set of swatch cards for hard surfaces, vertical surface fabrics, and seating upholstery

Paint

Tip: All products may not be available in all colors listed below.

- ▶ See page 676 for an overview of the paint colors available on each component.

Steelcase Surfaces

Price Group 1

Smooth Paint

- 4238 Mocha
- 4239 Clay
- 4240 Chalk
- 4242 Milk

Textured Paint

- 7207 Black
- 7225 Sand
- 7237 Slate **E**
- 7238 Fieldstone
- 7239 Midnight
- 7241 Arctic White
- 7243 Seagull
- 7250 Sterling Dark Solid
- 7360 Merle

Price Group 2

Smooth Metallic Paint

- 4743 Mineral Metallic
- 4750 Champagne Metallic
- 4798 Sterling Metallic
- 4799 Platinum Metallic
- 4803 Near Black Metallic

Smooth Paint

- 0835 Black
- 4700 Warm White

Textured Metallic Paint

- 7245 Carbon Metallic
- 7246 Midnight Metallic

Applies to:

- 2 1/2" round grommet

Price Group 1

Smooth Paint

- 7241 Arctic White

Textured Paint

- 7360 Merle

Price Group 2

Smooth Paint

- 0835 Black
- 4700 Warm White

Smooth Metallic Paint

- 4799 Platinum Metallic

Price Group 3

Accent paint

Accent paints allow you to choose from a pre-matched color palette of trend driven colors. Refer to the *Surface Materials Reference Manual* for more information.

Coatings

- 1ATT Cast Shadow

Lux Coatings

- 4B20 Obsidian
- 4B22 Matte Brass
- 4B23 Burnished Bronze
- 4B24 Night Bronze
- 4B25 Matte Copper
- 4B26 Smoked Mica
- 4B29 Cast Iron

Tip: Lux Coatings is not offered on Answer panels with a square or an oval trim.

Custom Surfaces

Price Group 3

PerfectMatch

PerfectMatch is a service that allows you to create your own paint color. Refer to the *Surface Materials Reference Manual* for more information about this program.

Applies to:

- Post legs

Price Group 1

- 7207 Black (Textured)

- 7225 Sand (Textured)

- 7241 Arctic White (Textured)

- 7243 Seagull (Textured)

Price Group 2

- 4750 Champagne Metallic

- 4798 Sterling Metallic

- 4799 Platinum Metallic

- 7246 Midnight Metallic (Textured)

Laminate

Steelcase Surfaces

Applies to:

- Duo storage boxes

Solid Laminate

- 2722 Cream **E**

- 2730 Arctic White

- 2746 Black

- 2759 Warm White

- 2811 Mist **E**

- 2883 Seagull

- 2884 Milk

- 2885 Dune

Applies to:

- Answer laminate skins
- High-Density storage
- Universal worksurfaces and tables—High-Pressure Laminate
- Universal storage tops
- Infills for FrameOne legs

High-Pressure Laminate

Price Group 1

Fiber Laminate

- 2850 Vanadium Fiber

- 2854 Vellum Fiber **E**

- 2860 Granite Fiber

- 2862 Stucco Fiber **E**

Micro Laminate

- 2920 Marl Micro

- 2921 Gypsum Micro

- 2922 Clay Micro

Patina Laminate

- 2870 Blonde Bronze Patina

- 2873 Instant Iron Patina

Solid Laminate

- 2722 Cream **E**

- 2730 Arctic White

- 2746 Black

- 2759 Warm White

- 2811 Mist **E**

- 2883 Seagull

- 2884 Milk

- 2885 Dune

- 2HAA Persian Salt

- 2HAB Rose

- 2HAC Indigo

- 2HAD Green Citrine

- 2HAE Dark Olivine

- 2HAF Cloudy

- 2HMG Merle

- 2HWJ Clay

- 2HW Chalk

Speckle Laminate

- 2820 Coffee Speckle **E**

- 2823 Driftwood Speckle

- 2824 Smoke Speckle

- 2825 Vanadium Speckle

Tip: Some wood veneer finishes and woodgrain laminates share the same name. Because of the difference in materials, veneers and laminates of the same name are not an exact match but do coordinate with each other.

Woodgrain Laminate

- 2406 Clear Cherry **E**

- 2409 Clear Maple

- 2410 Graphite Walnut

- 2412 Natural Cherry

- 2422 Medium Cherry

- 2511 Winter on Maple

- 2535 Virginia Walnut

- 2536 Blackwood

- 2538 Clear Walnut

- 2592 Blonde on Maple **E**

- 2714 Natural Walnut **E**

- 2HAK Clear Oak

- 2HAN Ash Noce

- 2HAT Acacia

- 2HAW Ash Wenge

- 2HBN Bisque Noce

- 2HBW Bisque Wenge

- 2HCN Clay Noce

- 2HCW Clay Wenge

- 2HSN Storm Noce

- 2HSW Storm Wenge

- 2HWA Grey Kingswood

- 2HWB Planked Walnut

- 2HWD Resolute Walnut

- 2HWE Natural Recon

- 2HWF Smoked Walnut

Tip: Woodgrain laminates are not available as a matched set. The grain patterns will not align. These are not recommended for fully segmented skin applications.

Tip: 2535 Virginia Walnut and 2536 Blackwood are not available on doors.

E = Established

Price Group 2**Textured Laminate**

2TH2	Fawn Cypress
2TH4	Saddle Oak
2TH5	Veranda Teak
2TH7	Walnut Heights
2UH1	Reclaimed Aggregate
2UH2	Reclaimed Gravel
2UH4	Cement**
2UH6	Sheetrock

** 2UH4 Cement has limited availability, determined by product sizing and/or options.

Price Group 3**Solid Laminate**

24H1	Satin White
24H2	Satin Black
24H3	Satin Stone
24H4	Satin Mocha

Custom Surfaces**Open Line Laminate (OLL)**

This service allows you to order non-standard laminate at an additional processing fee of \$102 U.S. per unit, plus the cost of the laminate.

High-Pressure Laminate pricing does not include premium or digitally printed patterns from any suppliers. Laminate cost may also vary for basic or standard laminates from other suppliers. Please contact the OLL consultant at 616.475.2426 for pricing. The cost of the laminate will be added to your invoice as a separate line on the acknowledgement.

When processing orders for Open Line laminate on Universal worksurfaces and Universal Storage tops, specify 2900 in the laminate finish field and enter the OLL manufacturer information. Enter the required edge finish as you would a standard laminate.

Laminate Approval and Material Requirements

To confirm whether a particular laminate has already been tested for use on a specific Steelcase product or to determine material square foot requirements:

- Visit www.steelcase.com

For additional information, refer to the *Steelcase Surface Materials Reference Manual*.

Wood

Applies to:

- Universal worksurfaces and tables—wood veneer
- Answer pedestal tops and fronts
- High-Density storage
- Universal storage tops and fronts
- Wood skins and trims
- Infills for FrameOne legs

Tip: Wood is not offered as a finish on the value package for High-Density storage cases.

Steelcase carefully selects veneer and solid wood for consistent color and grain structure. Wood is a natural material and variations will occur in color, grain and texture. These variations are part of the inherent natural beauty of wood and are not considered defects.

All wood products will darken with age and exposure to ultraviolet light. This is especially apparent with cherry and maple veneer. We recommend that desk accessories be rearranged periodically to ensure even aging of wood surfaces.

When storing your wood furniture, please follow the following guidelines:

- Do not store products in trailers
- Store products in areas that simulate office temperatures (60°F to 90°F)
- Store products in areas that maintain constant, office-like humidity levels
- Keep product away from light. Cover products to make sure they are not exposed to light.

Steelcase Surfaces

Veneers are matched for proper balance and consistency. Veneers are available flat cut or quarter cut, except for Oak, which is rift cut. Refer to the *Surface Materials Reference Manual* for descriptions of each cut.

Tip: Answer panel wood trims are only available with quarter-cut finishes with the exception of maple finishes. Maple on wood trims is only available with flat-cut finishes. For ordering simplicity, both flat-cut and quarter-cut finishes can be specified on panel trims. However, for all finishes except maple, if a flat-cut finish is selected, the trims will have the coordinating quarter-cut finish. For maple finishes, if quarter-cut is selected, the trims will have the coordinating flat-cut finish. Blending panel trims with other wood products that have flat-cut finishes may be visually acceptable for most applications. If a more exact match is desired for non-maple finishes, please specify quarter-cut finishes for the entire project. If a more exact match is desired for maple finishes, please specify flat-cut finishes for the entire project.

Open-pore finish is a medium gloss finish that leaves the wood grain texture visible to the eye and distinguishable to the touch.

Veneer**Wood Group 1****Flat-Cut Open-Pore**

3062	FC/OP Graphite Walnut
3402	FC/OP Clear Cherry (Aged)
3412	FC/OP Natural Cherry E
3422	FC/OP Medium Cherry
3522	FC/OP Clear Maple
3592	FC/OP Blonde on Maple E
3702	FC/OP Clear Walnut
3712	FC/OP Natural Walnut
3752	FC/OP Medium Walnut E
3762	FC/OP Dark Walnut
3772	FC/OP Medium Mahogany on Walnut

Flat-Cut Open-Pore, Natural Veneer

3342	FC/OP Black Walnut
35A2	FC/OP Blanch Maple
37A2	FC/OP Thunder Walnut

Quarter-Cut Open-Pore

3042	QC/OP Ash E
3222	QC/OP Clear Maple
3292	QC/OP Blonde on Maple E
3302	QC/OP Clear Walnut
3312	QC/OP Natural Walnut
3352	QC/OP Medium Walnut E
3362	QC/OP Dark Walnut
3372	QC/OP Medium Mahogany on Walnut
3382	QC/OP Graphite Walnut

Quarter-Cut Open-Pore, Natural Veneer

32A2	QC/OP Blanch Maple
33A2	QC/OP Thunder Walnut
3392	QC/OP Black Walnut

Rift-Cut Open-Pore

3602	RC/OP Desert Oak
------	------------------

Rift-Cut Full-Fill, Natural Veneer

36A2	RC/OP Volcanic Oak
------	--------------------

Wood Group 3**Flat-Cut Open-Pore, Natural Veneer**

3082	FC/OP Washed Walnut
------	---------------------

Wood Group 1**Open-Pore Planked Veneer**

3P41	OP Planked Cherry
3P51	OP Planked Maple
3P61	OP Planked Oak
3P71	OP Planked Walnut
3VFX	OP Unmarked Oak

Tip: Known for its uniqueness, planked veneer has intentional and natural variations that include, but are not limited to: character marks, grain pattern, color, and natural color aging.

E = Established

Full-Fill

Full-fill finish is a medium-gloss finish that completely fills the grain texture, yet allows the grain pattern to be seen. The wood has a lustrous, satiny look, and it is smooth to the touch. This finish is available on the wood worksurface or field-installed top only.

Wood Group 2

Flat-Cut Full-Fill

- 3064 FC/FF Graphite Walnut
- 3404 FC/FF Clear Cherry (Aged)
- 3414 FC/FF Natural Cherry **E**
- 3424 FC/FF Medium Cherry
- 3524 FC/FF Clear Maple
- 3544 FC/FF Blonde on Maple **E**
- 3704 FC/FF Clear Walnut
- 3714 FC/FF Natural Walnut
- 3754 FC/FF Medium Walnut **E**
- 3764 FC/FF Dark Walnut
- 3774 FC/FF Medium Mahogany on Walnut

Flat-Cut Full-Fill, Natural Veneer

- 3734 FC/FF Black Walnut

Quarter-Cut Full-Fill

- 3224 QC/FF Clear Maple
- 3294 QC/FF Blonde on Maple **E**
- 3304 QC/FF Clear Walnut
- 3314 QC/FF Natural Walnut
- 3354 QC/FF Medium Walnut **E**
- 3364 QC/FF Dark Walnut
- 3374 QC/FF Medium Mahogany on Walnut
- 3384 QC/FF Graphite Walnut

Quarter-Cut Full-Fill, Natural Veneer

- 3394 QC/FF Black Walnut

Rift-Cut Full-Fill

- 3604 RC/FF Desert Oak

Wood Group 3

Flat-Cut Full-Fill, Natural Veneer

- 3084 FC/FF Washed Walnut

Premium Veneers

A selection of Premium veneers in this collection are available on most Steelcase brand products. The collection will be available as close to standard leadtimes as possible. However, because adequate supplies of veneer and solids must be secured, all orders will be scheduled individually. Leadtimes will vary based on Premium veneer and Premium solids availability at the time the order is placed. The collection is available as Wood Group 3 as part of our Select Surfaces program and supported like standard veneers to make ordering easy. Please see the Steelcase surface materials section on village.steelcase.com for sample information and product line availability. All premium veneers are in clear-coat.

Wood Group 3

Quarter-Cut Open-Pore

- 3832 QC/OP Figured Anegre

Select Surfaces

Composite Veneer

Composite veneers are an engineered wood intended to create specific grain patterns and characteristics. They are pre-stained and finished with Steelcase's Clarity water-borne UV topcoat, which protects the environment while providing durability and clarity. Only open-pore finishes are available on composite wood. Composite veneer and matching edge bands are available on most Steelcase brand products. Composites, for use as a solid nosing substitute, are not available. Steelcase does not recommend mixing composite veneers with natural solid nosings because composite and natural wood grain and color matching are rarely compatible. Composite veneers are available as part of our Select Surfaces program, with Wood Group 1 pricing.

Composite veneers are not available on Answer trims.

Composite Veneer Group 1

Composite Flat-Cut Open-Pore

- 3JDX FC/OP Oak Composite
- 3JJX FC/OP Walnut Composite
- 3LAX FC/OP Graphite on Oak Composite
- 3LCX FC/OP Medium Cherry on Cherry Composite

Composite Quarter-Cut Open-Pore

- 3F8X QC/OP European Walnut Composite
- 3GGX QC/OP Zebrano Composite
- 3HGX QC/OP Oak Composite
- 3HVX QC/OP Walnut Composite
- 3LBX QC/OP Clear Walnut on Walnut Composite
- 3LDX QC/OP Natural Walnut on Walnut Composite
- 3ZNX QC/OP Night Cerused Oak Composite

Composite Veneer Group 2

Composite Flat-Cut Open-Pore

- 3LHX FC/OP Espresso on Walnut Composite

Composite Quarter-Cut Open-Pore

- 3LEX QC/OP Desert Oak on Oak Composite
- 3LGX QC/OP Chai on Walnut Composite
- 3LJX QC/OP Ebony on Walnut Composite

Custom Surfaces

Customiz stain is a service that allows you to create your own stain colors and finishes on standard veneer. Customiz stain color is available on all product lines that offer wood veneer.

A \$500 stain-matching fee applies on CUSTOMIZ requests (Exception: The \$500 fee does not apply on matches to Coalesse standard finishes or for a low-gloss finish request on a standard color). The \$500 fee covers the cost of formulating the Customiz color finish and applies regardless of whether or not an order for product is placed.

In addition, an approval form must be signed to indicate customer acceptance of Customiz match. A \$1,500 initiation fee will be charged prior to first order entry. This initiation fee activates the finish for unlimited use on any Steelcase product for an 18 month time period. After the 18 month time period has lapsed, the Customiz finish may be reactivated for another 18 months for a \$1,000 fee at any point within five years after the \$1,500 initiation fee was paid. If the finish is not reactivated within five years after the \$1,500 initiation fee was paid, the finish will be culled and the customer will need to pay the \$1,500 initiation fee again. All style number related Customiz charges products are no cost as of April 2014. The matching and initiation fees are not discountable.

Customiz stain takes 10 days to formulate. Consult the *Surface Materials Reference Manual* for more information. Custom veneers are also available and must be quoted by Steelcase specials group. Customiz stain on custom veneers takes 2 to 4 weeks to formulate.

Requirements and information on ordering a Customiz stain color are found in the *Surface Materials Reference Manual*.

E = Established

Plastic**Steelcase Surfaces**

Applies to:

- Oval trim components

6000 Black
6009 Arctic White
6052 Milk
6053 Seagull
6271 Plywood
6654 Sand
6655 Warm White
6685 Champagne
6686 Gold Dust **E**
6695 Midnight
6696 Sterling **E**
6697 Fog
6698 Fieldstone
6699 Platinum

Applies to:

- Oval pull

6000 Black
6249 Platinum Solid
6654 Sand
6695 Midnight
6698 Fieldstone

Applies to:

- Oval trim components
- Oval pulls

Tip: The following plastic is available for existing customers only. The matching paints have moved to the Surface Materials Reference Manual.

6651 Tungsten **E**

Applies to:

- Duplex cable grommets

6000 Black
6009 Arctic White
6249 Platinum Solid
6607 Woodrose
6608 Driftwood
6609 Smoke
6612 Grey V2
6655 Warm White **E**
6697 Fog
66WU Clay
66WV Chalk

Applies to:

- 3 mm and 1 mm front edge profile on Universal systems worksurfaces and tables
- 1 mm square edge profile on Universal storage laminate tops

6000 Black
6009 Arctic White
6034 Natural Cherry
6036 Medium Cherry
6037 Winter on Maple
6038 Blonde on Maple **E**
6041 Natural Walnut **E**
6052 Milk
6053 Seagull
6169 Stone
6170 Mocha
61AA Persian Salt
61AB Rose
61AC Indigo
61AD Green Citrine
61AE Dark Olivine
61AF Cloudy
6213 Acacia
6219 Clear Oak
6231 Graphite Walnut
6237 Clear Maple
6242 Virginia Walnut
6243 Blackwood **E**
6245 Clear Walnut
6249 Platinum Solid
6271 Plywood
6527 Merle
6619 Ice **E**
6631 Cream **E**
6635 Dawn **E**
6636 Mist
6654 Sand
6655 Warm White
6695 Midnight
6697 Fog
6698 Fieldstone
66WA Grey Kingswood
66WB Planked Walnut
66WD Resolute Walnut
66WE Natural Recon
66WF Smoked Walnut
66WU Clay
66WV Chalk
6703 Ash Wenge
6704 Storm Wenge
6705 Bisque Wenge
6706 Clay Wenge
6707 Ash Noce
6708 Bisque Noce
6709 Clay Noce
6710 Storm Noce
6T02 Fawn Cypress
6T04 Saddle Oak
6T05 Veranda Teak
6T07 Walnut Heights
6T08 Aggregate
6T09 Gravel
6T10 Cement
6T12 Sheetrock

Tip: Light color plastic edges are susceptible to degradation due to normal wear and tear. Staining (e.g., ball point pen or clothing dyes such as blue jeans) and dirt effects are more pronounced in light colors and are not considered defects.

Accessory Paint**Steelcase Surfaces**

Applies to:

- Adjustable-height legs with glides
 - Universal table bases
- 4140 Arctic White Gloss
4144 Black Gloss

Metal**Steelcase Surfaces**

Applies to:

- 2½ round grommet
- 9201 Polished Chrome
9211 Nickel

Applies to:

- X-base and T-base
- 8046 Polished Aluminum

Plated Metal**Steelcase Surfaces**

Applies to:

- Universal storage pulls
- 0835 Black
9201 Polished Chrome
9211 Nickel
9212 Silver

Glass**Steelcase Surfaces**

Applies to:

- Back painted glass skins
- 6521 Truffle
6571 Aubergine
6575 Peacock
6576 Jungle
6577 Merlot
6578 Lagoon
6579 Saffron
6581 Blue Jay
6584 Tangerine
6586 Green Citrine
6588 Purple Berry
6589 Mercury
6591 Merle
6593 Greyscale
6595 Winter
6597 Honey
6BB1 Cloud
6BB2 Rose Quartz
6BB3 Olivine
6BB4 Electric Indigo

Vertical Surface Fabric

▶ See *Surface Materials Reference Manual* for a listing of available fabrics for Divisio side screen.

Applies to:

- Fabric skins and trims

Steelcase Surfaces**Price Group A****Sprite**

5540 Khaki
5541 Snow
5543 Linen
5544 Sherbet
5545 Powder
5547 Sky

Price Group 1**Abacus **E****

P123 Portico
P124 Opus
P125 Cusp
P126 Artifact

Alloy

P525 Polar
P526 Skim
P527 Bubbly
P528 Tern
P529 Shore
P530 Asti
P531 Silver
P532 Oxide
P533 Element
P534 Construct
P535 Currency
P536 Iron

Boccie

P200 New Rice
P201 New Almond
P203 New Camel
P204 New Opal
P205 New Mist
P206 New Plum
P208 New Spearmint
P209 New Sky

Buzz2

5F03 Tomato
5F04 Red **E**
5F05 Burgundy
5F06 Sky **E**
5F07 Blue
5F08 Navy
5F15 Stone
5F16 Grey
5F17 Black
5G50 Dunegrass
5G51 Sable
5G55 Pumpkin
5G57 Rouge
5G59 Meadow
5G61 Cyan
5G62 Atlantic
5G63 Crocus
5G64 Alpine
5G65 Tornado

E = Established

Charm

- P505 Shell
- P506 Mimosa
- P507 Birch
- P508 Sparkle
- P510 Debut
- P511 Clover
- P513 Twilight

Optic

- P540 Hazel
- P541 Twinkle
- P542 Orion
- P543 Seaglass
- P546 Whiskey
- P547 Bath
- P548 Whisper
- P549 Breezy
- P551 Glimmer

Pianista

- P420 Sand
- P421 Mist
- P422 Rain
- P423 Natural
- P424 Café
- P425 Denim
- P426 Carbon
- P427 Stone
- P428 Flax
- P429 Oat
- P430 Wheat
- P431 Maize

Rhythm

- P555 Allegro
- P556 Tempo
- P557 Refrain
- P558 Pitch
- P560 Melody
- P562 Opus

Tinsel

- P515 Sugar
- P516 Lit
- P517 Ego
- P518 Fizz
- P519 Muse
- P520 Depth
- P521 Bliss
- P522 Grow
- P523 Dolce
- P524 Boost

Price Group 2

Bariolage

- G200 New Etude
- G201 New Andante **E**
- G202 New Cantata **E**
- G203 New Adagio
- G205 New Ballata

Code

- 5FA1 Fossil
- 5FA2 Gabbro
- 5FA3 Reed
- 5FA4 Bluff
- 5FA5 Sea Salt
- 5FA6 Cannon
- 5FA7 Tussah
- 5FA8 Mica
- 5FA9 Ecu
- 5FB1 Bamboo

Dovetail by Designtex

- 5H39 Light Mocha
- 5H40 Pebble
- 5H41 Warm White
- 5H42 Sandstone
- 5H43 Honeycomb
- 5H44 Terra
- 5H45 Honeydew
- 5H46 Denim
- 5H47 Storm
- 5H48 Ice Blue
- 5H49 Aura
- 5H50 Darkest Grey

Flip: Orbit

- 5F85 Mud Pie **E**
- 5F87 Petoskey
- 5F88 Pluto **E**
- 5F89 Papyrus
- 5F91 Blizzard
- 5F92 Briquette

Flip: TexHex

- 5F75 Mud Pie **E**
- 5F77 Petoskey
- 5F78 Pluto **E**
- 5F79 Papyrus
- 5F97 Blizzard
- 5F98 Briquette

Fresco

- G001 Sandrift
- G002 Mistiblu
- G003 Faon
- G006 Chamoline

Intersection

- P211 Summit
- P212 Chalk
- P213 Lace

Latch

- P600 Seashell
- P601 Clam
- P602 Eggshell
- P603 Zen
- P604 Cool Gray
- P605 Armor
- P606 Sentinel
- P607 Rye
- P608 Billow
- P609 Nimbus

SoftNext

- 5H27 Obsidian
- 5H28 Foggy Night
- 5H29 Greystone
- 5H30 Mocha
- 5H31 Clay
- 5H32 Sandstone
- 5H33 Chalk
- 5H34 Midnight
- 5H35 Blue Mica
- 5H36 Jade
- 5H37 Burnt Umber
- 5H38 Cinnabar

Stencil

- P455 Midnight
- P456 Mulberry
- P457 Cracked Pepper
- P458 Denim
- P459 Chartreuse
- P460 Bittersweet
- P461 Mauvelous
- P462 Bermuda
- P463 Concrete
- P464 Orchid
- P465 Parchment
- P466 Silk
- P467 Sea Salt
- P468 Honeydew
- P469 Sepia

Price Group 3

Billiard Multi-Use by Designtex

- 5H11 Poppy
- 5H12 Tangelo
- 5H13 Citrine/Citron
- 5H14 Avocado
- 5H16 Indigo
- 5H17 Mallard
- 5H18 Teak
- 5H19 Cumulus
- 5H20 Pewter
- 5H21 Gunmetal
- 5H22 Ink
- 5H23 Rose Quartz
- 5H24 Sea Salt
- 5H25 Storm Cloud
- 5H26 Olivine

Applies to:

- Universal screens

Price Group 1

- Abacus **E**
- Buzz2

Price Group 2

- Code
- Cogent: Connect
- Crossweave by Designtex
- Dovetail by Designtex
- Gamut by Designtex
- Intersection
- Latch
- SoftNext
- Stencil
- Tip: Designtex: Gamut and Designtex: Crossweave are part of the Select Surfaces program.*

▶ See Surface Materials Reference Manual for more information on the Select Surfaces program.

Price Group 3

- Billiard Multi-Use by Designtex

Applies to:

- Sarto screens

Price Group A

- Sprite

Price Group 1

- Abacus **E**
- Alloy
- Boccie
- Buzz2
- Charm
- Link
- Optic
- Pianista
- Rhythm

Price Group 2

- Bariolage
- Cogent: Connect
- Dovetail by Designtex
- Flip: Orbit
- Flip: TexHex
- Fresco
- Intersection
- Latch
- SoftNext
- Stencil

Applies to:

- Universal screens
- Sarto screens

Price Group 6

- Fusion

Select Surfaces

For information on products within Select Surfaces, including accent paints and fabrics from Designtex, Gabriel, Kvadrat, and Pollack, please refer to the *Surface Materials Reference Manual* or visit steelcase.com/surface-materials under the Select Surfaces section.

Custom Surfaces

Price Group COM (Customer's Own Material)

Fabric Approval and Yardage

To confirm whether a particular COM material has already been tested for use on a specific Steelcase product or to determine actual yardage requirements:

- Visit www.steelcase.com

For additional information regarding Customer's Own Material, call

1.888.STEELCASE (1.888.783.3522) or send an e-mail to lineone@steelcase.com.

▶ See *Surface Materials Reference Manual* for a listing of available seating upholstery colors.

E = Established

Seating Upholstery

► See *Surface Materials Reference Manual* for a listing of available fabrics for Divisio side screen.

Applies to:

- Mobile pedestal cushion top
- Basic cushion enhanced

*Not available on basic cushion enhanced

Steelcase Surfaces**Price Group 1**

Buzz2

Era

Jacks **E**

Link

New Black

Tip: New Black upholstery has color numbers in both price group 1 and price group 2.

Price Group 2

Chainmail

Cogent: Connect

Dovetail by DesignTex

Foundation*

New Black

Nitelights

SoftNext

Stand In*

Tip: New Black upholstery has color numbers in both price group 1 and price group 2.

Price Group 3

Billiard Multi-Use by

DesignTex

Gaja

Redeem

Retrieve

Price Group 5

Bo Peep

Remix

Price Group 6

Brisa*

Price Group 7

Steelcut Trio*

Leather

Café*

Steelcase Leather*

Elmosoft Leather

Elmosoft Leather*

Applies to:

- High-Density storage magnetic board

Price Group 2

Cogent: Connect

Price Group 3

Billiard Multi-Use by

DesignTex

Select Surfaces

For information on products within Select Surfaces, including accent paints and fabrics from DesignTex, Gabriel, Kvadrat, and Pollack, please refer to the *Surface Materials Reference Manual* or visit steelcase.com/surface-materials under the Select Surfaces section.

Custom Surfaces**Price Group COM (Customer's Own Material)****Fabric Approval and Yardage**

To confirm whether a particular COM material has already been tested for use on a specific Steelcase product or to determine actual yardage requirements:

- Visit www.steelcase.com

E = Established

Specification Guidelines for Directional Fabrics

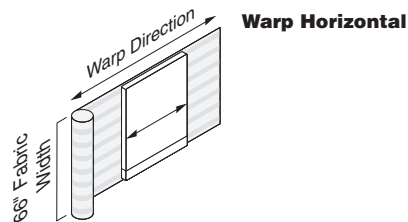

The standard application direction of fabric on Answer panels, skins, and Hutch kit tackboard is warp horizontal. Standard Steelcase fabrics were designed for this application direction.

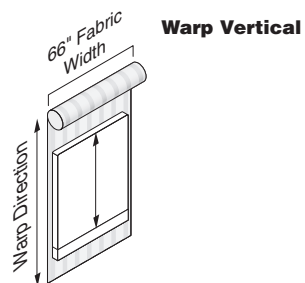

The optional application direction of fabrics on Answer panels, skins, and Hutch kit tackboard is warp vertical. This is most commonly used on COMs designed for warp vertical application.

For more information about the warp direction of fabrics, see the *Surface Materials Reference Manual*.

Recommended Worksurface Edge Finishes

Recommended Edge Colors—High-Pressure Laminate

Edges

The recommended edge color will complement the laminate color you specify. Edge color is specified separately.

Laminate Color	Recommended 3 mm or 1 mm Edge Color
----------------	-------------------------------------

Fiber Laminate

2850	Vanadium Fiber	6654	Sand
2851	Rhyme Fiber E	6631	Cream E
2854	Vellum Fiber E	6655	Warm White
2859	Novell Fiber	6695	Midnight Solid
2860	Granite Fiber	6000	Black
2861	Coconut Fiber	6654	Sand
2862	Stucco Fiber E	6053	Seagull

Micro Laminate

2920	Marl Micro	6053	Seagull
2921	Gypsum Micro	6654	Sand
2922	Clay Micro	6654	Sand

Patina Laminate

2870	Blonde Bronze Patina	6654	Sand
2873	Instant Iron Patina	6527	Merle

Solid Laminate

24H1	Satin White	6009	Arctic White
24H2	Satin Black	6000	Black
24H3	Satin Stone	6169	Stone
24H4	Satin Mocha	6170	Mocha
2722	Cream E	6631	Cream E
2730	Arctic White	6009	Arctic White
2746	Black	6000	Black
2759	Warm White	6655	Warm White
2811	Mist E	6636	Mist
2883	Seagull	6053	Seagull
2884	Milk	6052	Milk
2885	Dune	6654	Sand
2HAA	Persian Salt	61AA	Persian Salt
2HAB	Rose	61AB	Rose
2HAC	Indigo	61AC	Indigo
2HAD	Green Citrine	61AD	Green Citrine
2HAE	Dark Olivine	61AE	Dark Olivine
2HAF	Cloudy	61AF	Cloudy
2HMG	Merle	6527	Merle
2HWU	Clay	66WU	Clay
2HWV	Chalk	66WV	Chalk

Speckle Laminate

2820	Coffee Speckle E	6631	Cream E
2823	Driftwood Speckle	6631	Cream E
2824	Smoke Speckle	6636	Mist
2825	Vanadium Speckle	6619	Ice E

► Recommended Worksurface Edge Finishes, continued on next page

Laminate Color	Recommended 3 mm or 1 mm Edge Color
----------------	-------------------------------------

Textured Laminate

2TH2	Fawn Cypress	6T02	Fawn Cypress
2TH4	Saddle Oak	6T04	Saddle Oak
2TH5	Veranda Teak	6T05	Veranda Teak
2TH7	Walnut Heights	6T07	Walnut Heights
2UH1	Reclaimed Aggregate	6T08	Aggregate
2UH2	Reclaimed Gravel	6T09	Gravel
2UH4	Cement	6T10	Cement
2UH6	Sheetrock	6T12	Sheetrock

Woodgrain Laminate

2406	Clear Cherry E	6234	Clear Cherry
2409	Clear Maple	6237	Clear Maple
2410	Graphite Walnut	6231	Graphite Walnut
2412	Natural Cherry	6034	Natural Cherry
2422	Medium Cherry	6036	Medium Cherry
2511	Winter on Maple	6037	Winter on Maple
2535	Virginia Walnut	6242	Virginia Walnut
2536	Blackwood E	6243	Blackwood E
2538	Clear Walnut	6245	Clear Walnut
2592	Blonde on Maple E	6038	Blonde on Maple E
2714	Natural Walnut E	6041	Natural Walnut E
2HAK	Clear Oak	6219	Clear Oak
2HAN	Ash Noce	6707	Ash Noce
2HAT	Acacia	6213	Acacia
2HAW	Ash Wenge	6703	Ash Wenge
2HBN	Bisque Noce	6708	Bisque Noce
2HBW	Bisque Wenge	6705	Bisque Wenge
2HCN	Clay Noce	6709	Clay Noce
2HCW	Clay Wenge	6706	Clay Wenge
2HSN	Storm Noce	6710	Storm Noce
2HSW	Storm Wenge	6704	Storm Wenge
2HWA	Grey Kingswood	66WA	Grey Kingswood
2HWB	Planked Walnut	66WB	Planked Walnut
2HWD	Resolute Walnut	66WD	Resolute Walnut
2HWE	Natural Recon	66WE	Natural Recon
2HWF	Smoked Walnut	66WF	Smoked Walnut

E = Established

Directional Laminate Grain Directions

Directional laminates are standard with the grain directions shown.

Universal Systems Worksurfaces—High-Pressure Laminate



Universal Tables—High-Pressure Laminate



Straight
Table



Capsule
Table



Spanner
Table



Peninsula
Table



Tapered Peninsula
Table



Round
Table



Square
Table



Rectangle
Table



Oval
Table



Hex Conference
Table

Wood Veneer Grain Directions

The appearance of wood veneer may change slightly depending on the angle from which it is viewed. This natural phenomenon is called polarization, and it can be seen on natural veneer, and to a lesser extent on composite veneer. Polarization is often noticed on worksurfaces installed at a 90-degree angle with each other. Please refer to the following illustrations for an understanding of grain direction on your installation.

Universal Systems Worksurfaces—Wood Veneer

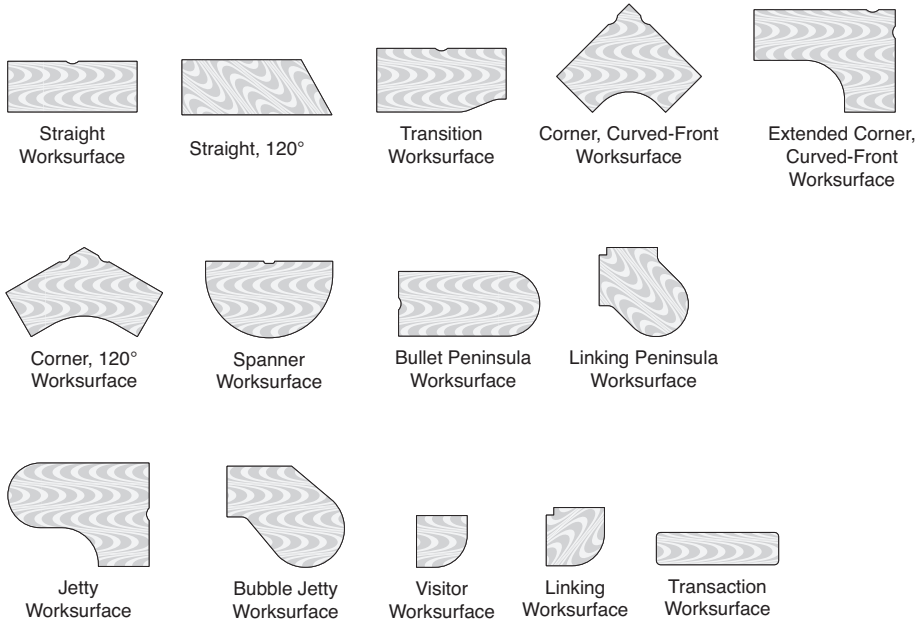

Universal Tables—Wood Veneer

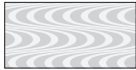

Straight
Table

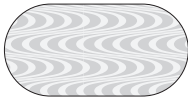

Capsule
Table



Spanner
Table



Peninsula
Table

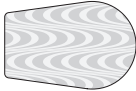

Tapered Peninsula
Table



Round
Table



Square
Table

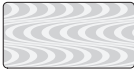

Rectangle
Table

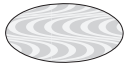

Oval Table

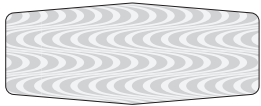

Hex Conference Table



Resources

**Lock and Keying for Universal Steel Storage Products
and High-Density Storage**

686

Style Number Index

688

Lock and Keying for Universal Steel Storage Products and High-Density Storage

All locking products are standard with factory-installed, keyed-random locks. Consecutive, specific, and random keying are available as field-installed options. *Exception: Individual locking drawers are only available with field-installed locks.*

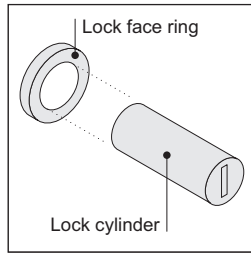

Locks consist of a factory- or field-installed lock cylinder and a factory-installed lock face ring.

Two types of locks are available — the standard keying system (FR series) and the master keying system (XF series). All the locks in the XF series can be opened with a single master key.

Factory-Installed Keying

Factory-installed locks are always key random (standard) or master key random (option). Key random means that the locks will be assigned arbitrarily at the factory with key numbers ranging from FR305 to FR454 (Master keying numbers: XF1001 to XF1150). All locks within a unit will be keyed alike.

Tip: Random keying can mean that different furniture units will have the same key number. If you must have all locks keyed differently, you should specify field-installed, key specific or key consecutive lock cylinders.

▶ See below.

Key Random

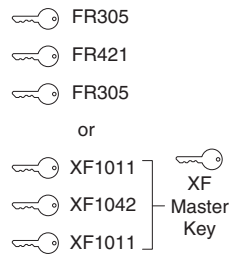

Required to Specify

Master key random	+\$36	Specify with master key random.
--------------------------	-------	---------------------------------

Field-Installed Keying

Field-installed locks are only available on products that include factory-installed lock mechanisms.

Specify "plug" when specifying furniture, and the product will ship with a plastic plug in place of the lock cylinder.

Front-removable lock cylinders must be specified separately. You must also order a special lock tool to install or remove lock cylinders in the field.

Tip: Lock tools are reusable. You do not need to order additional lock tools with every furniture order.

Lock cylinders will be shipped separately so that you can install the locks when you are ready.

Three keying choices

are available for field installation—random (standard), specific, and consecutive. All three are also available with master keying, which means that all locks can be opened with a single master key.

Key random means that the locks will be assigned arbitrarily at the factory with key numbers ranging from FR305 to FR454 (Master keying numbers: XF1001 to XF1150).

Tip: Random keying can mean that different furniture units will have the same key number. If you must have all locks keyed differently, you should specify key specific or key consecutive lock cylinders.

Key Random

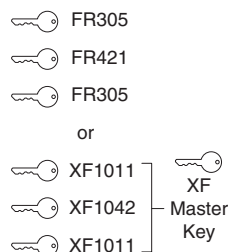

Key specific means that you can specify any key number from FR305 to FR454 (Master keying numbers: XF1001 to XF1150). This option can be used to key all the furniture units in a workstation or department the same.

Tip: Designate the quantity per key number in your specification.

▶ See example at right.

Key Specific

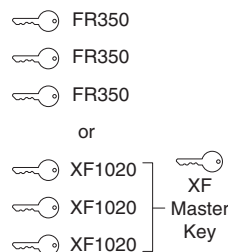

Key consecutive

means that you can specify lock numbers in a consecutive order to ensure that no two locks have the same key number until the key sequence repeats. You must select a beginning key number from FR305 to FR454 (Master keying numbers: XF1001 to XF1150).

Example of a typical lock cylinder specification is shown below:

10	LOCK9201FR FR320
5	LOCK9201FR FR350
15	LOCK9201XF XF1100
30	Total
1	877102003SR standard lock tool
1	877102002SR master lock tool

Key Consecutive

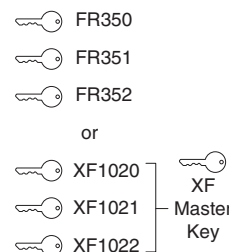

Field-Installed Lock Cylinders

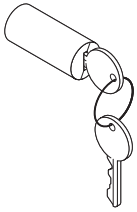

Tip: Lock price is included in price of furniture with locks.

Tip: For replacement lock cylinders, refer to Service Parts.

Standard Includes		Required to Specify
<ul style="list-style-type: none"> Lock cylinder: 9201 Polished Chrome or 9250 Ember Chrome Two keys 		1 Style number 2 Options, if selected (see below)

Options	U.S. Price	Required to Specify
Key specific	No cost	Select key number from FR305–FR454.
Key consecutive	No cost	Specify <i>key consecutive</i> and select beginning key number from FR305–FR454.
Master key random	+\$36 each	Specify <i>master key random</i> .
Master key specific	+\$36 each	Specify key number from XF1001–XF1150.
Master key consecutive	+\$36 each	Specify <i>master key consecutive</i> and select beginning key number from XF1001–XF1150.

Specification Information		
Color	Style Number	U.S. Base Price
:	:	:
:	:	:

FR Series (Standard Keying System)—Lock Cylinder

Polished Chrome	LOCK9201FR	No cost
Ember Chrome	LOCK9250FR	No cost
:	:	:

Standard Lock Tool

	877102003SR	\$36
:	:	:

XF Series (Master Keying System)—Lock Cylinder

Polished Chrome	LOCK9201XF	No additional cost. Price included in price of furniture with master-keyed locks.
Ember Chrome	LOCK9250XF	No additional cost. Price included in price of furniture with master-keyed locks.
:	:	:

Master Lock Tool

	877102002SR	\$36
:	:	:

Tip: You can change lock cylinders in the field by using the appropriate lock tool.

 **For Canadian Pricing**
Multiply U.S. Price by the Canadian price factor.
▶ See page 1 for details.

Style Number Index

Style Number	Page	Description
800DV12	657	Dividers
800DV6	657	Dividers
800RW	657	Rail
877102002SR	687	Master Lock Tool
877102003SR	687	Standard Lock Tool
98765	576	Termination Plate
98766	576	Cable/Fiber Reel
98767	577	Cord Reels
98863	498	Dx Cable Grom
999CHT	577	Wire Clips
AWAG2	575	2 1/2" Round Grommet
AWVBP	575	Power/Power Box
AWVW	577	Wire Mgr
BADJ	592	U Tbl Adj-Hgt Leg
BADJ4	592	U Tbl Adj-Hgt Leg
BADJ4C	592	U Tbl Adj-Hgt Leg
BADJC	592	U Tbl Adj-Hgt Leg
BDTD54	665	Shared Tall Storage
BDTD54ANL	664	Shared Tall Storage
BDTD66	665	Shared Tall Storage
BDTD66ANL	664	Shared Tall Storage
BDTD78ANL	664	Shared Tall Storage
BDTS54	665	Individual Tall Storage
BDTS54ANL	664	Individual Tall Storage
BDTS66	665	Individual Tall Storage
BDTS66ANL	664	Individual Tall Storage
BDTS78ANL	664	Individual Tall Storage
BEL2142	589	U Tbl Oval
BEL3042	589	U Tbl Oval
BEL3060	589	Univ Tbl Oval
BEL3648	589	U Tbl Oval
BEL3672	589	U Tbl Oval
BEL4278	589	U Tbl Oval
BEL4896	589	U Tbl Oval
BFK2448	582	U Tbl Capsule
BFK3060	582	U Tbl Capsule
BFK3672	582	U Tbl Capsule
BFK4284	582	U Tbl Capsule
BFK4896	582	U Tbl Capsule
BFP2736	584	U Tbl Pnsl
BFR30	586	U Tbl Round
BFR36	586	U Tbl Round
BFR42	586	U Tbl Round
BFR48	586	U Tbl Round
BFR54	586	U Tbl Round
BFRQ24	587	U Tbl Square
BFRQ30	587	Univ Tbl Square
BFRQ36	587	U Tbl Square
BFRQ42	587	U Tbl Square
BFRQ48	587	U Tbl Square
BFRQ54	587	U Tbl Square
BFRR3660	588	U Tbl Rectangle
BFRR3666	588	U Tbl Rectangle
BFRR3672	588	U Tbl Rectangle
BFRR4284	588	U Tbl Rectangle
BFRR4896	588	U Tbl Rectangle
BFS2430	581	U Tbl Str
BFS2436	581	U Tbl Str
BFS2442	581	Univ Tbl Str
BFS2448	581	U Tbl Str
BFS2454	581	U Tbl Str

Style Number	Page	Description
BFS2460	581	U Tbl Str
BFS2466	581	U Tbl Str
BFS2472	581	U Tbl Str
BFS2478	581	U Tbl Str
BFS3036	581	U Tbl Str
BFS3042	581	U Tbl Str
BFS3048	581	U Tbl Str
BFS3054	581	U Tbl Str
BFS3060	581	U Tbl Str
BFS3066	581	U Tbl Str
BFS3072	581	U Tbl Str
BFS3078	581	U Tbl Str
BFSP48	583	U Tbl Spnr
BFSP52	583	U Tbl Spnr
BFSP60	583	U Tbl Spnr
BFSP64	583	U Tbl Spnr
BFTP48	585	U Tbl Taprd Pnsl
BFTP60	585	U Tbl Taprd Pnsl
BHEX3660	590	Univ Tbl Hex Conf
BHEX3666	590	U Tbl Hex Conf
BHEX3672	590	U Tbl Hex Conf
BHEX4296	590	U Tbl Hex Conf
BHEX48120	590	U Tbl Hex Conf
BHEX48150	590	U Tbl Hex Conf
BHEX48180	590	U Tbl Hex Conf
BHHCX	496, 549	Connector
BHHCY	496, 549	Connector
BHHCZ	496, 549	Connector
BPL	593	U Tbl Post Leg
BPL4	593	U Tbl Post Leg
BPL4C	593	U Tbl Post Leg
BPLC	593	U Tbl Post Leg
BT26	591	Univ Tbl Base
BT36	591	U Tbl Hex Conf
BX26	591	U Tbl Base
BX36	591	U Tbl Base
CBRKTS	343, 411	Flr Anchor Bracket
DVSS2912	571	Divisio Side Screen
FCD20	548	Center Drawer
FMVF	550	Filler Pkg Pwr/Data
FSCD20	548	Center Drawer
GQTUHCX	496, 549	Connector
GQTUHCY	496, 549	Connector
GQTUHCZ	496, 549	Connector
GSGUH100X	494	Internode Harness
GSGUH100XN	494	Modular Harness
GSGUH100Y	494	Modular Harness
GSGUH100YN	494	Modular Harness
GSGUH100Z	495	Modular Harness
GSGUH100ZN	495	Modular Harness
GSGUH120X	494	Modular Harness
GSGUH120XN	494	Modular Harness
GSGUH120Y	494	Modular Harness
GSGUH120YN	494	Modular Harness
GSGUH120Z	495	Modular Harness
GSGUH120ZN	495	Modular Harness
GSGUH12X	494	Modular Harness
GSGUH12XN	494	Modular Harness
GSGUH12Y	494	Modular Harness
GSGUH12YN	494	Modular Harness
GSGUH12Z	495	Modular Harness

Style Number	Page	Description
GSGUH12ZN	495	Modular Harness
GSGUH144X	494	Modular Harness
GSGUH144XN	494	Modular Harness
GSGUH144Y	494	Modular Harness
GSGUH144YN	494	Modular Harness
GSGUH144Z	495	Modular Harness
GSGUH144ZN	495	Modular Harness
GSGUH22X	494	Modular Harness
GSGUH22XN	494	Modular Harness
GSGUH22Y	494	Modular Harness
GSGUH22YN	494	Modular Harness
GSGUH22Z	495	Modular Harness
GSGUH22ZN	495	Modular Harness
GSGUH28X	494	Modular Harness
GSGUH28XN	494	Modular Harness
GSGUH28Y	494	Modular Harness
GSGUH28YN	494	Modular Harness
GSGUH28Z	495	Modular Harness
GSGUH28ZN	495	Modular Harness
GSGUH32X	494	Modular Harness
GSGUH32XN	494	Modular Harness
GSGUH32Y	494	Modular Harness
GSGUH32YN	494	Modular Harness
GSGUH32Z	495	Modular Harness
GSGUH32ZN	495	Modular Harness
GSGUH38X	494	Modular Harness
GSGUH38XN	494	Modular Harness
GSGUH38Y	494	Modular Harness
GSGUH38YN	494	Modular Harness
GSGUH38Z	495	Modular Harness
GSGUH38ZN	495	Modular Harness
GSGUH44X	494	Modular Harness
GSGUH44XN	494	Modular Harness
GSGUH44Y	494	Modular Harness
GSGUH44YN	494	Modular Harness
GSGUH44Z	495	Modular Harness
GSGUH44ZN	495	Modular Harness
GSGUH50X	494	Modular Harness
GSGUH50XN	494	Modular Harness
GSGUH50Y	494	Modular Harness
GSGUH50YN	494	Modular Harness
GSGUH50Z	495	Modular Harness
GSGUH50ZN	495	Modular Harness
GSGUH54X	494	Modular Harness
GSGUH54XN	494	Modular Harness
GSGUH54Y	494	Modular Harness
GSGUH54YN	494	Modular Harness
GSGUH54Z	495	Modular Harness
GSGUH54ZN	495	Modular Harness
GSGUH64X	494	Modular Harness
GSGUH64XN	494	Modular Harness
GSGUH64Y	494	Modular Harness
GSGUH64YN	494	Modular Harness
GSGUH64Z	495	Modular Harness
GSGUH64ZN	495	Modular Harness
GSGUH76X	494	Modular Harness
GSGUH76XN	494	Modular Harness
GSGUH76Y	494	Modular Harness
GSGUH76YN	494	Modular Harness
GSGUH76Z	495	Modular Harness
GSGUH76ZN	495	Modular Harness

Style Number	Page	Description	Style Number	Page	Description	Style Number	Page	Description
GSGUH88X	494	Modular Harness	RATCL24108_	653	Square Edge Top	RBB48WTAK	612	U Ovr the Case Bin
GSGUH88XN	494	Modular Harness	RATCL2460_	653	Square Edge Top	RBB60LTAK	612	U In the Case Bin
GSGUH88Y	494	Modular Harness	RATCL2466_	653	Square Edge Top	RBB60QTAK	609	U Ovr the Case Bin
GSGUH88YN	494	Modular Harness	RATCL2472_	653	Square Edge Top	RBB60TAK	611	U In the Case Bin
GSGUH88Z	495	Modular Harness	RATCL2490_	653	Square Edge Top	RBB60WTAK	612	U In the Case Bin
GSGUH88ZN	495	Modular Harness	RATCL2496_	653	Square Edge Top	RBB66LTAK	612	U In the Case Bin
HDPNLCNT	646	Panel Conn Bracket	RATCL3636_	653	Square Edge Top	RBB66QTAK	609	U Ovr the Case Bin
HDSTG	642	High-Density Storage	RATCL3672_	653	Square Edge Top	RBB66TAK	611	U In the Case Bin
HDSTGV	645	High-Den Strg Val Pckg	RATCL4836_	653	Square Edge Top	RBB66WTAK	612	U In the Case Bin
HDWS	646	Wrksrf Supp Bracket	RATCL4872_	653	Square Edge Top	RBB72LTAK	612	U In the Case Bin
KDIV02	658	Bookends	RATCW1860_	653	Square Edge Top	RBB72QTAK	609	U Ovr the Case Bin
KDIV20	658	Bookends	RATCW1866_	653	Square Edge Top	RBB72TAK	611	U In the Case Bin
LOCK9201FR	687	Lock Cylinder	RATCW1872_	653	Square Edge Top	RBB72WTAK	612	U In the Case Bin
LOCK9201XF	687	Lock Cylinder	RATCW1878_	653	Square Edge Top	RBKVOFM	615	Vert OM Brkt
LOCK9250FR	687	Lock Cylinder	RATCW1884_	653	Square Edge Top	RCHE1715	605	Bsc Cushion E
LOCK9250XF	687	Lock Cylinder	RATCW1890_	653	Square Edge Top	RCHE1830	627	Bsc Cushion E
PAB12	662	Attachment Cable	RATCW1896_	653	Square Edge Top	RCHE1836	627	Bsc Cushion E
PAB12M	662	Attachment Cable	RATCW2460_	653	Square Edge Top	RCHE1842	627	Bsc Cushion E
PSCB	570	Sarto Almnt Clip	RATCW2466_	653	Square Edge Top	RCHE2315	605	Bsc Cushion E
PSPM	567	Sarto Privacy Screens	RATCW2472_	653	Square Edge Top	RCHE2430	627	Bsc Cushion E
PSPS	569	Sarto Privacy Screens	RATCW2490_	653	Square Edge Top	RCHE2436	627	Bsc Cushion E
PTDMGB1	574	Power Sphere	RATCW2496_	653	Square Edge Top	RDD182448LA_	634	U Dual Door Tower
PTDMGB3	574	Pwr Comm Sphere	RATF1830F	650	Steel Security Top	RDD182448LB_	634	U Dual Door Tower
PTRSGB1	574	Power Comm Port	RATF1830P	650	Steel Security Top	RDD182448RA_	636	U Dual Door Tower
R30MBB	618	Flexible Mb Surf	RATF1836F	650	Steel Security Top	RDD182448RB_	636	U Dual Door Tower
R36MBB	618	Flexible Mb Surf	RATF1836P	650	Steel Security Top	RDD18244LA_	634	U Dual Door Tower
R42MBB	618	Flexible Mb Surf	RATF1842F	650	Steel Security Top	RDD18244LB_	635	U Dual Door Tower
R48MBB	618	Flexible Mb Surf	RATF1842P	650	Steel Security Top	RDD18244RA_	636	U Dual Door Tower
RAACT1	660	Counterweight Pkg	RATF2430F	650	Steel Security Top	RDD18244RB_	637	U Dual Door Tower
RAACT2	660	Counterweight Pkg	RATF2430P	650	Steel Security Top	RDD18245LC_	635	U Dual Door Tower
RAACT3	660	Counterweight Pkg	RATF2436F	650	Steel Security Top	RDD18245LD_	635	U Dual Door Tower
RAACW1	660	Counterweight Pkg	RATF2436P	650	Steel Security Top	RDD18245RC_	637	U Dual Door Tower
RAACW2	660	Counterweight Pkg	RATL1830_	652	Square Edge Top	RDD18245RD_	637	U Dual Door Tower
RAACW3	660	Counterweight Pkg	RATL1836_	652	Square Edge Top	RDD242448LA_	634	U Dual Door Tower
RAACW30	659	Counterweight Pkg	RATL1842_	652	Square Edge Top	RDD242448LB_	634	U Dual Door Tower
RAACW36	659	Counterweight Pkg	RATL2430_	652	Square Edge Top	RDD242448RA_	636	U Dual Door Tower
RAACW4	660	Counterweight Pkg	RATL2436_	652	Square Edge Top	RDD242448RB_	636	U Dual Door Tower
RAACW42	659	Counterweight Pkg	RATW1830_	653	Square Edge Top	RDD24244LA_	634	U Dual Door Tower
RAACW5	660	Counterweight Pkg	RATW1836_	653	Square Edge Top	RDD24244LB_	635	U Dual Door Tower
RAACW6	660	Counterweight Pkg	RATW1842_	653	Square Edge Top	RDD24244RA_	636	U Dual Door Tower
RAACW7	660	Counterweight Pkg	RATW2430_	653	Square Edge Top	RDD24244RB_	637	U Dual Door Tower
RAACW8	660	Counterweight Pkg	RATW2436_	653	Square Edge Top	RDD24245LC_	635	U Dual Door Tower
RAACWD	659	Counterweight Pkg	RBB24LTAK	612	U In the Case Bin	RDD24245LD_	635	U Dual Door Tower
RAACWE	659	Counterweight Pkg	RBB24QTAK	609	U Ovr the Case Bin	RDD24245RC_	637	U Dual Door Tower
RAACWF	659	Counterweight Pkg	RBB24TAK	611	U In the Case Bin	RDD24245RD_	637	U Dual Door Tower
RAACWR	660	CW Retro Kit	RBB24WTAK	612	U In the Case Bin	RDIV	614	Dividers
RAANBRK	661	Anchor Bracket Pkg	RBB30LTAK	612	U In the Case Bin	RDS24TAK	614	U Personal Shelf
RAHF30	656	Hanging Folder Bars	RBB30QTAK	609	U Ovr the Case Bin	RDS30TAK	614	U Personal Shelf
RAHF36	656	Hanging Folder Bars	RBB30TAK	611	U In the Case Bin	RDS36TAK	614	U Personal Shelf
RAHF42	656	Hanging Folder Bars	RBB30WTAK	612	U In the Case Bin	RDS42TAK	614	U Personal Shelf
RASTDIV30	658	Shelf Div Assembly	RBB36LTAK	612	U In the Case Bin	RDS48TAK	614	U Personal Shelf
RASTDIV36	658	Shelf Div Assembly	RBB36QTAK	609	U Ovr the Case Bin	RDV1506	655	Dividers
RASTDIV42	658	Shelf Div Assembly	RBB36TAK	611	U In the Case Bin	RDV1512	655	Dividers
RATCL18108_	652	Square Edge Top	RBB36WTAK	612	U In the Case Bin	RDV151210	655	Dividers
RATCL1860_	652	Square Edge Top	RBB42LTAK	612	U In the Case Bin	RLF18301_	623	U One-High Lat File
RATCL1866_	652	Square Edge Top	RBB42QTAK	609	U Ovr the Case Bin	RLF18301A_	623	U 1.5-High Lat File
RATCL1872_	652	Square Edge Top	RBB42TAK	611	U In the Case Bin	RLF18301B_	624	U 1.5-High Lat File
RATCL1878_	652	Square Edge Top	RBB42WTAK	612	U In the Case Bin	RLF18301C_	624	U 1.5-High Lat File
RATCL1884_	652	Square Edge Top	RBB48LTAK	612	U In the Case Bin	RLF18301D_	624	U 1.5-High Lat File
RATCL1890_	652	Square Edge Top	RBB48QTAK	609	U Ovr the Case Bin	RLF18302_	624	U Lat File
RATCL1896_	652	Square Edge Top	RBB48TAK	611	U In the Case Bin	RLF18361_	623	U One-High Lat File

Style Number Index, continued

Style Number	Page	Description
RLF18361A	623	U 1.5-High Lat File
RLF18361B	624	U 1.5-High Lat File
RLF18361C	624	U 1.5-High Lat File
RLF18361D	624	U 1.5-High Lat File
RLF18362	624	U Lat File
RLF18421	623	U One-High Lat File
RLF18421A	623	U 1.5-High Lat File
RLF18421B	624	U 1.5-High Lat File
RLF18421C	624	U 1.5-High Lat File
RLF18421D	624	U 1.5-High Lat File
RLF18422	624	U Lat File
RLF24301A	623	U 1.5-High Lat File
RLF24301B	624	U 1.5-High Lat File
RLF24301C	624	U 1.5-High Lat File
RLF24301D	624	U 1.5-High Lat File
RLF24302	624	U Lat File
RLF24361A	623	U 1.5-High Lat File
RLF24361B	624	U 1.5-High Lat File
RLF24361C	624	U 1.5-High Lat File
RLF24361D	624	U 1.5-High Lat File
RLF24362	624	U Lat File
RPCW	600	U Ped Counterwght
RPDC1830	626	Cushion Top
RPDC1836	626	Cushion Top
RPDC1842	626	Cushion Top
RPDC2430	626	Cushion Top
RPDC2436	626	Cushion Top
RPF1827A	599	U Fixed Pedestal
RPF1827B	599	U Fixed Pedestal
RPF2427A	599	U Fixed Pedestal
RPF2427B	599	U Fixed Pedestal
RPF3027A	599	U Fixed Pedestal
RPF3027B	599	U Fixed Pedestal
RPM1821C	604	U Mobile Pedestal
RPM1827A	604	U Mobile Pedestal
RPM1827B	604	U Mobile Pedestal
RPM2421C	604	U Mobile Pedestal
RPM2427A	604	U Mobile Pedestal
RPM2427B	604	U Mobile Pedestal
RPULL15W	659	Wood Drawer Pull
RPULL30W	659	Wood Drawer Pull
RPULL36W	659	Wood Drawer Pull
RPULL42W	659	Wood Drawer Pull
RPXCK2718F	601	U Conv Kit
RPXCK2718P	601	U Conv Kit
RPXCK2724F	601	U Conv Kit
RPXCK2724P	601	U Conv Kit
RPXCK2730F	601	U Conv Kit
RPXCK2730P	601	U Conv Kit
RPXDPT	656	Pencil Tray
RPXDRS	656	Reference Shelf
RPXFTAKFP	600	U Fil Prd Frnt Ped
RPXFTAKPP	600	U Fil Prd Frnt Ped
RPXTC24F	604	U Ped Cushion Top
RPXTC24P	604	U Ped Cushion Top
RPXTCH24F	604	U Ped Cushion Top
RPXTCH24P	604	U Ped Cushion Top
RQS182448LA	630	U Open Side Tower
RQS182448RA	631	U Open Side Tower
RQS182448LA	630	U Open Side Tower
RQS182448RA	631	U Open Side Tower

Style Number	Page	Description
RQS18245LC	630	U Open Side Tower
RQS18245RC	631	U Open Side Tower
RQS242448RA	630	U Open Side Tower
RQS242448RA	631	U Open Side Tower
RQS24244LA	630	U Open Side Tower
RQS24244RA	631	U Open Side Tower
RQS24245LC	630	U Open Side Tower
RQS24245RC	631	U Open Side Tower
RSB36LTAK	607	U Sldg Dr Bin Lam Frnt
RSB36TAK	607	U Sldg Dr Bin Stl Frnt
RSB36WTAK	607	U Sldg Dr Bin Wd Frnt
RSB42LTAK	607	U Sldg Dr Bin Lam Frnt
RSB42TAK	607	U Sldg Dr Bin Stl Frnt
RSB42WTAK	607	U Sldg Dr Bin Wd Frnt
RSB48LTAK	607	U Sldg Dr Bin Lam Frnt
RSB48TAK	607	U Sldg Dr Bin Stl Frnt
RSB48WTAK	607	U Sldg Dr Bin Wd Frnt
RSB60LTAK	607	U Sldg Dr Bin Lam Frnt
RSB60TAK	607	U Sldg Dr Bin Stl Frnt
RSB60WTAK	607	U Sldg Dr Bin Wd Frnt
RSB66LTAK	607	U Sldg Dr Bin Lam Frnt
RSB66TAK	607	U Sldg Dr Bin Stl Frnt
RSB66WTAK	607	U Sldg Dr Bin Wd Frnt
RSB72LTAK	607	U Sldg Dr Bin Lam Frnt
RSB72TAK	607	U Sldg Dr Bin Stl Frnt
RSB72WTAK	607	U Sldg Dr Bin Wd Frnt
RSC18301A	623	U One-High Lat File
RSC18361A	623	U One-High Lat File
RSC18421A	623	U One-High Lat File
RSH24TAK	613	U Shelf
RSH30TAK	613	U Shelf
RSH36TAK	613	U Shelf
RSH42TAK	613	U Shelf
RSH48TAK	613	U Shelf
RSH60TAK	613	U Shelf
RSH72TAK	613	U Shelf
RSS24TAK	619	Slim Shelf
RSS30TAK	619	Slim Shelf
RSS36TAK	619	Slim Shelf
RSS42TAK	619	Slim Shelf
RSS48TAK	619	Slim Shelf
RSS60TAK	619	Slim Shelf
RSS72TAK	619	Slim Shelf
RSS96TAK	619	Slim Shelf
RUK24TAK	616	Stnd OH Upmnt Pkg
RUK30TAK	616	Stnd OH Upmnt Pkg
RUK36TAK	616	Stnd OH Upmnt Pkg
RUK42TAK	616	Stnd OH Upmnt Pkg
RUK48TAK	616	Stnd OH Upmnt Pkg
RUK60TAK	616	Stnd OH Upmnt Pkg
RUK72TAK	616	Stnd OH Upmnt Pkg
RXADRL15	655	Rails
RXADRL24	657	Rails
RXADRL2442	657	Rails
RXSA2415	654	Adj Steel Std Shelf
RXSA3015	654	Adj Steel Std Shelf
RXSAFFT2415	654	Adj Steel Std Shelf
RXSG2415	654	Adjustable Glass Shelf
RXSG3015	654	Adjustable Glass Shelf
TS7120JB3	357	120° Jct Block
TS7120JB4	357	120° Jct Block

Style Number	Page	Description
TS7120JB5	357	120° Jct Block
TS7120JC	358	120° Jct Cap
TS7120JCW	358	120° Jct Cap
TS7120VA4	359	120° to V Trim Aligner
TS71218GS	466	Back Ptd Glass Skin
TS71218HS	443	Steel Pnl Skin
TS71218MB	448	MB Surf Pnl Bldp
TS71218TA	436	F-Cvrd Pnl Skin
TS71218TK	436	F-Cvrd Pnl Skin
TS71224GS	466	Back Ptd Glass Skin
TS71224HS	443	Steel Pnl Skin
TS71224LS	452	Lam Skin
TS71224MB	448	Mb Skin
TS71224MBS	447	Mb Surf Steel Skin
TS71224SBP	451	Slatwall Skin Brc Pkg
TS71224SCW	476	Sgl-Pane Gls Win Kit
TS71224SFG	433	Frameless Gls Screen
TS71224SPW	475	Sgl-Pane Glass Win
TS71224SW	450	Slatwall Skin
TS71224TA	436	F-Cvrd Pnl Skin
TS71224TFG	368	Frameless Glass
TS71224TFGR	365	Frameless Glass
TS71224TK	436	F-Cvrd Pnl Skin
TS71224TSMB	473	Mb Tech Skin
TS71224TSS	471	Stl Tech Skin
TS71224TSSW	472	Slatwall Tech Skin
TS71224WS	454	Wood Skin
TS71230GS	466	Back Ptd Glass Skin
TS71230HS	443	Steel Pnl Skin
TS71230LS	452	Lam Skin
TS71230LTSMB	473	Mk Tech Skin, LH Co
TS71230LTSS	471	Stl Tech Skin, LH Co
TS71230LTSSW	472	Sw Tech Skin, LH Co
TS71230MB	448	Mb Skin
TS71230MBS	447	Mb Surf Steel Skin
TS71230RTSMB	473	Mb Tech Skin, RH Co
TS71230RTSS	471	St Tech Skin, RH Co
TS71230RTSSW	472	Sw Tech Skin, RH Co
TS71230SBP	451	Sw Skin Brace Pkg
TS71230SCW	476	Sgl-Pane Gls Win Kit
TS71230SFG	433	Frameless Gls Screen
TS71230SPW	475	Sgl-Pane Glass Win
TS71230SW	450	Slatwall Skin
TS71230TA	436	F-Cvrd Pnl Skin
TS71230TFG	368	Frameless Glass
TS71230TFGR	365	Frameless Glass
TS71230TK	436	F-Cvrd Pnl Skin
TS71230TSMB	473	Mb Tech Skin
TS71230TSS	471	Stl Tech Skin
TS71230TSSW	472	Slatwall Tech Skin
TS71230WS	454	Wood Skin
TS71236GS	466	Back Ptd Glass Skin
TS71236HS	443	Steel Pnl Skin
TS71236LS	452	Lam Skin
TS71236LTSMB	473	MB Tech Skin, LH Co
TS71236LTSS	471	Stl Tech Skin, LH Co
TS71236LTSSW	472	SW Tech Skin, LH Co
TS71236MB	448	Mb Skin
TS71236MBS	447	MB Surf for Steel Skin
TS71236RTSMB	473	Mb Tech Skin, RH Co
TS71236RTSS	471	Stl Tech Skin, RH Co

Style Number	Page	Description	Style Number	Page	Description	Style Number	Page	Description
TS71236RTSSW	472	SW Tech Skin, RH Co	TS71248WS	454	Wood Skin	TS712LPJS	414	Stck L Pnl Jct
TS71236SBP	451	SW Skin Brace Pkg	TS71254TFGR	365	Frameless Glass	TS712SCH	424	C-O-H Trim
TS71236SCW	476	Sgl-Pane Gls Win Kit	TS71260GS	466	Back Ptd Gls Skin	TS712SCHS	424	C-O-H Trim
TS71236SFG	433	Frameless Gls Screen	TS71260HS	443	Steel Pnl Skin	TS712T120CHT	355	120° Cor C-O-H Trim
TS71236SPW	475	Sgl-Pane Glass Win	TS71260LTSS	471	Stl Tech Skin, LH Co	TS712T120CHTW	355	120° Cor C-O-H Trim
TS71236SW	450	Slatwall Skin	TS71260MB	448	Mb Skin	TS712TCLCHT	354	L Cor C-O-H Trim
TS71236TA	436	F-Cvrd Pnl Skin	TS71260RTSS	471	Stl Tech Skin, RH Co	TS712TCLCHTW	354	L Cor C-O-H Trim
TS71236TFG	368	Frameless Glass	TS71260SCW	476	Sgl-Pane Gls Win Kit	TS712TCTCHT	354	T Cor C-O-H Trim
TS71236TFGR	365	Frameless Glass	TS71260SFG	433	Frameless Gls Scrn	TS712TCTCHTW	354	T Cor C-O-H Trim
TS71236TK	436	F-Cvrd Pnl Skin	TS71260SPW	475	Sgl-Pane Glass Win	TS712TEPJS	345	Stck EOR Pnl Jct
TS71236TSMB	473	Mb Tech Skin	TS71260TA	436	F-Cvrd Pnl Skin	TS712TICHT	353	EOR In-Line COH Trim
TS71236TSS	471	Stl Tech Skin	TS71260TFG	368	Frameless Glass	TS712TICHTW	353	EOR In-Line COH Trim
TS71236TSSW	472	Slatwall Tech Skin	TS71260TFGR	365	Frameless Glass	TS712TLPJS	346	Stck L Pnl Jct
TS71236WS	454	Wood Skin	TS71260TK	436	F-Cvrd Pnl Skin	TS712TPJS	414	Stck T Pnl Jct
TS71242GS	466	Back Ptd Gls Skin	TS71260TSS	471	Stl Tech Skin	TS712TTPJS	346	Stacking T Pnl Jct
TS71242HS	443	Steel Pnl Skin	TS71266TFGR	365	Frameless Glass	TS712TVCHT	355	V Cnr C-O-H Trim
TS71242LS	452	Lam Skin	TS71272GS	466	Back Ptd Gls Skin	TS712TVCHTW	355	V Cnr C-O-H Trim
TS71242LTSMB	473	MB Tech Skin, LH Co	TS71272HS	443	Steel Pnl Skin	TS712TVPJS	346	Stck V Pnl Jct
TS71242LTSS	471	Stl Tech Skin, LH Co	TS71272LTSS	471	Stl Tech Skin, LH Co	TS712UPHX	492	Mul. Pwr Infeed
TS71242LTSSW	472	SW Tech Skin, LH Co	TS71272MB	448	Mb Skin	TS712UPHXN	492	Mul. Pwr Infeed
TS71242MB	448	Mb Skin	TS71272RTSS	471	Stl Tech Skin, RH Co	TS712UPHY	492	Mul. Pwr Infeed
TS71242MBS	447	MB Surf for Stl Skin	TS71272SCW	476	Sgl-Pane Gls Win Kit	TS712UPHYN	492	Mul. Pwr Infeed
TS71242RTSMB	473	MB Tech Skin, RH Co	TS71272SFG	433	Frameless Gls Screen	TS712UPHZ	492	Mul. Pwr Infeed
TS71242RTSS	471	Stl Tech Skin, RH Co	TS71272SPW	475	Sgl-Pane Glass Win	TS712UPHZN	492	Mul. Pwr Infeed
TS71242RTSSW	472	SW Tech Skin, RH Co	TS71272TA	436	F-Cvrd Pnl Skin	TS712VPJS	416	Stck V Pnl Jct
TS71242SBP	451	SW Skin Brace Pkg	TS71272TFG	368	Frameless Glass	TS712WPJS	345, 417	Stck Wall-Start Jct
TS71242SCW	476	Sgl-Pane Gls Win Kit	TS71272TFGR	365	Frameless Glass	TS712XPJS	346, 414	Stck X Pnl Jct
TS71242SFG	433	Frameless Gls Screen	TS71272TK	436	F-Cvrd Pnl Skin	TS712YPJS	346, 416	Stck Y Pnl Jct
TS71242SPW	475	Sgl-Pane Glass Win	TS71272TSS	471	Stl Tech Skin	TS71324TSSC	370	Sarto Top Cap Screen
TS71242SW	450	Slatwall Skin	TS71278SCW	476	Sgl-Pane Gls Win Kit	TS71324TUSC	370	Univ Top Cap Screen
TS71242TA	436	F-Cvrd Pnl Skin	TS71278SFG	433	Frameless Gls Scrn	TS71330TSSC	370	Sarto Top Cap Screen
TS71242TFG	368	Frameless Glass	TS71278SPW	475	Sgl-Pane Gls Win	TS71330TUSC	370	Univ Top Cap Screen
TS71242TFGR	365	Frameless Glass	TS71278TFG	368	Frameless Glass	TS71336TSSC	370	Sarto Top Cap Screen
TS71242TK	436	F-Cvrd Pnl Skin	TS71278TFGR	365	Frameless Glass	TS71336TUSC	370	Univ Top Cap Screen
TS71242TSMB	473	Mb Tech Skin	TS71284SCW	476	Sgl-Pane Gls Win Kit	TS71342TUSC	370	Univ Top Cap Screen
TS71242TSS	471	Stl Tech Skin	TS71284SFG	433	Frameless Gls Scrn	TS71348TSSC	370	Sarto Top Cap Screen
TS71242TSSW	472	Slatwall Tech Skin	TS71284SPW	475	Sgl-Pane Gls Win	TS71348TUSC	370	Univ Top Cap Screen
TS71242WS	454	Wood Skin	TS71284TFG	368	Frameless Glass	TS71354TSSC	370	Sarto Top Cap Screen
TS71248GS	466	Back Ptd Gls Skin	TS71284TFGR	365	Frameless Glass	TS71354TUSC	370	Univ Top Cap Screen
TS71248HS	443	Steel Pnl Skin	TS71290SCW	476	Sgl-Pane Gls Win Kit	TS71360TSSC	370	Sarto Top Cap Screen
TS71248LS	452	Lam Skin	TS71290SFG	433	Frameless Gls Scrn	TS71360TUSC	370	Univ Top Cap Screen
TS71248LTSMB	473	MB Tech Skin, LH Co	TS71290SPW	475	Sgl-Pane Glass Win	TS71366TSSC	370	Sarto Top Cap Screen
TS71248LTSS	471	Stl Tech Skin, LH Co	TS71290TFG	368	Frameless Glass	TS71366TUSC	370	Univ Top Cap Screen
TS71248LTSSW	472	SW Tech Skin, LH Co	TS71290TFGR	365	Frameless Glass	TS71372TSSC	370	Sarto Top Cap Screen
TS71248MB	448	Mb Skin	TS71296SCW	476	Sgl-Pane Gls Win Kit	TS71372TUSC	370	Univ Top Cap Screen
TS71248MBS	447	MB Surf for Stl Skin	TS71296SFG	433	Frameless Gls Screen	TS71378TSSC	371	Sarto Top Cap Screen
TS71248RTSMB	473	MB Tech Skin, RH Co	TS71296SPW	475	Sgl-Pane Glass Win	TS71378TUSC	371	Univ Top Cap Screen
TS71248RTSS	471	Stl Tech Skin, RH Co	TS71296TFG	368	Frameless Glass	TS71384TSSC	371	Sarto Top Cap Screen
TS71248RTSSW	472	SW Tech Skin, RH Co	TS71296TFGR	365	Frameless Glass	TS71384TUSC	371	Univ Top Cap Screen
TS71248SBP	451	SW Skin Brace Pkg	TS712BPSFX	489	Bs Pwr Infeed	TS71390TSSC	371	Sarto Top Cap Screen
TS71248SCW	476	Sgl-Pane Gls Win Kit	TS712BPSFY	489	Bs Pwr Infeed	TS71390TUSC	371	Univ Top Cap Screen
TS71248SFG	433	Frameless Gls Scrn	TS712BPSFZ	489	Bs Pwr Infeed	TS71396TSSC	371	Sarto Top Cap Screen
TS71248SPW	475	Sgl-Pane Glass Win	TS712BPX	489	Bs Pwr Infeed	TS71396TUSC	371	Univ Top Cap Screen
TS71248SW	450	Slatwall Skin	TS712BPY	489	Bs Pwr Infeed	TS714WSP	552	U Support Plate
TS71248TA	436	F-Cvrd Pnl Skin	TS712BPZ	489	Bs Pwr Infeed	TS71818GS	466	Back Ptd Gls Skins
TS71248TFG	368	Frameless Glass	TS712CH	425	C-O-H Trim	TS71818HS	443	Steel Pnl Skin
TS71248TFGR	365	Frameless Glass	TS712CHS	425	C-O-H Trim	TS71818MB	448	MB Surf for Panel Bldp
TS71248TK	436	F-Cvrd Pnl Skin	TS712CHST	426	Stck C-O-H Trim	TS71818TA	436	F-Cvrd Pnl Skin
TS71248TSMB	473	Mb Tech Skin	TS712CHT	426	Stck C-O-H Trim	TS71818TK	436	F-Cvrd Pnl Skin
TS71248TSS	471	Stl Tech Skin	TS712EPJS	415	Stck EOR Pnl Jct	TS71824GS	466	Back Ptd Gls Skin
TS71248TSSW	472	Slatwall Tech Skin	TS712IPJS	345, 413	Stck In-Line Pnl Jct	TS71824HS	443	Steel Pnl Skin

Style Number Index, continued

Style Number	Page	Description
TS71824LS	452	Lam Skin
TS71824MB	448	Mb Skin
TS71824SBP	451	SW Skin Brace Pkg
TS71824SCW	476	Sgl-Pane Gls Win Kit
TS71824SPW	475	Sgl-Pane Glass Win
TS71824SW	450	Slatwall Skin
TS71824TA	436	F-Cvrd Pnl Skin
TS71824TB	617	TB Use w/Wall Chan
TS71824TFGR	365	Frameless Glass
TS71824TK	436	F-Cvrd Pnl Skin
TS71824TSMB	473	Mb Tech Skin
TS71824TSS	471	Stl Tech Skin
TS71824TSSW	472	Slatwall Tech Skin
TS71824WS	454	Wood Skin
TS71830GS	466	Bk Ptd Gls Skin
TS71830HS	443	Steel Pnl Skin
TS71830LS	452	Lam Skin
TS71830LTSMB	473	MB Tech Skin, LH Co
TS71830LTSS	471	Stl Tech Skin, LH Co
TS71830LTSSW	472	SW Tech Skin, LH Co
TS71830MB	448	Mb Skin
TS71830RTSMB	473	MB Tech Skin, RH Co
TS71830RTSS	471	Stl Tech Skin, RH Co
TS71830RTSSW	472	SW Tech Skin, RH Co
TS71830SBP	451	SW Skin Brace Pkg
TS71830SCW	476	Sgl-Pane Gls Win Kit
TS71830SPW	475	Sgl-Pane Glass Win
TS71830SW	450	Slatwall Skin
TS71830TA	436	F-Cvrd Pnl Skin
TS71830TB	617	TB Use w/Wall Chan
TS71830TFGR	365	Frameless Glass
TS71830TK	436	F-Cvrd Pnl Skin
TS71830TSMB	473	Mb Tech Skin
TS71830TSS	471	Stl Tech Skin
TS71830TSSW	472	Slatwall Tech Skin
TS71830WS	454	Wood Skin
TS71836GS	466	Back Ptd Gls Skn
TS71836HS	443	Steel Pnl Skin
TS71836LS	452	Lam Skin
TS71836LTSMB	473	MB Tech Skin, LH Co
TS71836LTSS	471	Stl Tech Skin, LH Co
TS71836LTSSW	472	SW Tech Skin, LH Co
TS71836MB	448	Mb Skin
TS71836RTSMB	473	MB Tech Skin, RH Co
TS71836RTSS	471	Stl Tech Skin, RH Co
TS71836RTSSW	472	SW Tech Skin, RH Co
TS71836SBP	451	Stl Skin Brace Pkg
TS71836SCW	476	Sgl-Pane Gls Win Kit
TS71836SPW	475	Sgl-Pane Glass Win
TS71836SW	450	Slatwall Skin
TS71836TA	436	F-Cvrd Pnl Skin
TS71836TB	617	TB Use w/Wall Chan
TS71836TFGR	365	Frameless Glass
TS71836TK	436	F-Cvrd Pnl Skin
TS71836TSMB	473	Mb Tech Skin
TS71836TSS	471	Stl Tech Skin
TS71836TSSW	472	Slatwall Tech Skin
TS71836WS	454	Wood Skin
TS71842GS	466	Back Ptd Gls Skin
TS71842HS	443	Steel Pnl Skin
TS71842LS	452	Lam Skin

Style Number	Page	Description
TS71842LTSMB	473	MB Tech Skin, LH Co
TS71842LTSS	471	Stl Tech Skin, LH Co
TS71842LTSSW	472	SW Tech Skin, LH Co
TS71842MB	448	Mb Skin
TS71842RTSMB	473	MB Tech Skin, RH Co
TS71842RTSS	471	Stl Tech Skin, RH Co
TS71842RTSSW	472	SW Tech Skin, RH Co
TS71842SBP	451	SW Skin Brace Pkg
TS71842SCW	476	Sgl-Pane Gls Win Kit
TS71842SPW	475	Sgl-Pane Glass Win
TS71842SW	450	Slatwall Skin
TS71842TA	436	F-Cvrd Pnl Skin
TS71842TB	617	TB Use w/Wall Chan
TS71842TFGR	365	Frameless Glass
TS71842TK	436	F-Cvrd Pnl Skin
TS71842TSMB	473	Mb Tech Skin
TS71842TSS	471	Stl Tech Skin
TS71842TSSW	472	Slatwall Tech Skin
TS71842WS	454	Wood Skin
TS71848GS	466	Back Ptd Gls Skin
TS71848HS	443	Steel Pnl Skin
TS71848LS	452	Lam Skin
TS71848LTSMB	473	MB Tech Skin, LH Co
TS71848LTSS	471	Stl Tech Skin, LH Co
TS71848LTSSW	472	SW Tech Skin, LH Co
TS71848MB	448	Mb Skin
TS71848RTSMB	473	MB Tech Skin, RH Co
TS71848RTSS	471	Stl Tech Skin, RH Co
TS71848RTSSW	472	SW Tech Skin, RH Co
TS71848SBP	451	SW Skin Brace Pkg
TS71848SCW	476	Sgl-Pane Gls Win Kit
TS71848SPW	475	Sgl-Pane Glass Win
TS71848SW	450	Slatwall Skin
TS71848TA	436	F-Cvrd Pnl Skin
TS71848TB	617	TB Use w/Wall Chan
TS71848TFGR	365	Frameless Glass
TS71848TK	436	F-Cvrd Pnl Skin
TS71848TSMB	473	Mb Tech Skin
TS71848TSS	471	Stl Tech Skin
TS71848TSSW	472	Slatwall Tech Skin
TS71848WS	454	Wood Skin
TS71854TFGR	365	Frameless Glass
TS71860GS	466	Back Ptd Glass Skin
TS71860HS	443	Steel Pnl Skin
TS71860LTSS	471	Stl Tech Skin, LH Co
TS71860MB	448	Mb Skin
TS71860RTSS	471	Stl Tech Skin, RH Co
TS71860SCW	476	Sgl-Pane Gls Win Kit
TS71860SPW	475	Sgl-Pane Glass Win
TS71860TA	436	F-Cvrd Pnl Skin
TS71860TB	617	TB Use w/Wall Chan
TS71860TFGR	365	Frameless Glass
TS71860TK	436	F-Cvrd Pnl Skin
TS71860TSS	471	Stl Tech Skin
TS71860TFGR	365	Frameless Glass
TS71872GS	466	Back Ptd Gls Skin
TS71872HS	443	Steel Pnl Skin
TS71872LTSMB	471	Stl Tech Skin, LH Co
TS71872MB	448	Mb Skin
TS71872RTSS	471	Stl Tech Skin, RH Co
TS71872SCW	476	Sgl-Pane Gls Win Kit

Style Number	Page	Description
TS71872SPW	475	Sgl-Pane Glass Win
TS71872TA	436	F-Cvrd Pnl Skin
TS71872TB	617	TB Use w/Wall Chan
TS71872TFGR	365	Frameless Glass
TS71872TK	436	F-Cvrd Pnl Skin
TS71872TSS	471	Stl Tech Skin
TS71878SCW	476	Sgl-Pane Gls Win Kit
TS71878SPW	475	Sgl-Pane Glass Win
TS71878TFGR	365	Frameless Glass
TS71884SCW	476	Sgl-Pane Gls Win Kit
TS71884SPW	475	Sgl-Pane Glass Win
TS71884TFGR	365	Frameless Glass
TS71890SCW	476	Sgl-Pane Gls Win Kit
TS71890SPW	475	Sgl-Pane Glass Win
TS71890TFGR	365	Frameless Glass
TS71896SCW	476	Sgl-Pane Gls Win Kit
TS71896SPW	475	Sgl-Pane Glass Win
TS71896TFGR	365	Frameless Glass
TS718BT	399	Base Trim
TS718CH	425	C-O-H Trim
TS718CHS	425	C-O-H Trim
TS718CHST	426	Stck C-O-H Trim
TS718CHT	426	Stck C-O-H Trim
TS718CT	481	Cable Tray
TS718EPJS	415	Stck EOR Pnl Jct
TS718HF	430	Base Horiz Frame Pkg
TS718HFS	362, 431	Stck Horiz Frame Pkg
TS718HSBOB	446	Stl Pnl Skn B O Base
TS718IPJS	345, 413	Stck In-Line Pnl Jct
TS718LPJS	414	Stck L Pnl Jct
TS718OBK	399	Opn Bs Conver Kit
TS718SCH	424	C-O-H Trim
TS718SCHS	424	C-O-H Trim
TS718SHF	429	Base Horiz Frame Pkg
TS718T120CHT	355	120° Cnr C-O-H Trim
TS718T120CHTW	355	120° Cnr C-O-H Trim
TS718TCLCHT	354	L Cnr C-O-H Trim
TS718TCLCHTW	354	L Cnr C-O-H Trim
TS718TCTCHT	354	T Cnr C-O-H Trim
TS718TCTCHTW	354	T Cnr C-O-H Trim
TS718TEPJS	345	Stck EOR Pnl Jct
TS718THF	361	Base Horiz Frame Pkg
TS718TICHT	353	EOR In-Line COH Trim
TS718TICHTW	353	EOR In-Line COH Trim
TS718TKBOB	440	Fb Cvd Pnl S B O Bs
TS718TLPJS	346	Stck L Pnl Jct
TS718TPJS	414	Stck T Pnl Jct
TS718TTPJS	346	Stck T Pnl Jct
TS718TVCHT	355	V Cnr C-O-H Trim
TS718TVCHTW	355	V Cnr C-O-H Trim
TS718TVPJS	346	Stck V Pnl Jct
TS718VPJS	416	Stck V Pnl Jct
TS718WPJS	345, 417	Stck Wall-Start Jct
TS718XPJS	346, 414	Stck X Pnl Jct
TS718YPJS	346, 416	Stck Y Pnl Jct
TS71924TSSC	371	Sarto Top Cap Screen
TS71924TUSC	371	Univ Top Cap Screen
TS71930TSSC	371	Sarto Top Cap Screen
TS71930TUSC	371	Univ Top Cap Screen
TS71936TSSC	371	Sarto Top Cap Screen
TS71936TUSC	371	Univ Top Cap Screen

Style Number	Page	Description	Style Number	Page	Description	Style Number	Page	Description
TS71942TSSC	371	Sarto Top Cap Screen	TS72430GSF	468	Bk Ptd Gls Flr Skin	TS72448HS	443	Steel Pnl Skin
TS71942TUSC	371	Univ Top Cap Screen	TS72430HS	443	Steel Pnl Skin	TS72448HSF	445	Steel To The Flr Skin
TS71948TSSC	371	Sarto Top Cap Screen	TS72430HSF	445	Steel To The Flr Skin	TS72448LS	452	Lam Skin
TS71948TUSC	371	Univ Top Cap Screen	TS72430LS	452	Lam Skin	TS72448LSF	453	Lam To The Flr Skin
TS71954TSSC	371	Sarto Top Cap Screen	TS72430LSF	453	Lam To The Flr Skin	TS72448MB	448	Mkd Skin
TS71954TUSC	371	Univ Top Cap Screen	TS72430MB	448	Mb Skin	TS72448MBF	449	Mkd to the Floor Skin
TS71960TSSC	371	Sarto Top Cap Screen	TS72430MBF	449	MB to the Floor Skin	TS72448MBS	447	Mkd Surf for Steel Skin
TS71960TUSC	371	Univ Top Cap Screen	TS72430MBS	447	MB Surf for Stl Skin	TS72448SBP	451	SW Skin Brace Pkg
TS71966TSSC	371	Sarto Top Cap Screen	TS72430SBP	451	SW Skin Brace Pkg	TS72448SCW	476	Sgl-Pane Gls Win Kit
TS71966TUSC	371	Univ Top Cap Screen	TS72430SCW	476	Sgl-Pane Gls Win Kit	TS72448SPW	475	Sgl-Pane Glass Win
TS71972TSSC	371	Sarto Top Cap Screen	TS72430SPW	475	Sgl-Pane Glass Win	TS72448SW	450	Slatwall Skin
TS71972TUSC	371	Univ Top Cap Screen	TS72430SW	450	Slatwall Skin	TS72448TA	436	F-Cvrd Pnl Skin
TS71978TSSC	371	Sarto Top Cap Screen	TS72430TA	436	F-Cvrd Pnl Skin	TS72448TAF	438	F-Cvrd To The Flr Skin
TS71978TUSC	371	Univ Top Cap Screen	TS72430TAF	438	F-Cvrd The Flr Skin	TS72448TFGR	366	Frameless Glass
TS71984TSSC	371	Sarto Top Cap Screen	TS72430TFGR	366	Frameless Glass	TS72448TK	436	F-Cvrd Pnl Skin
TS71984TUSC	371	Univ Top Cap Screen	TS72430TK	436	F-Cvrd Pnl Skin	TS72448TKF	438	F-Cvrd To The Flr Skin
TS71990TSSC	371	Sarto Top Cap Screen	TS72430TKF	438	F-Cvrd The Flr Skin	TS72448WS	454	Wood Skin
TS71990TUSC	371	Univ Top Cap Screen	TS72430WS	454	Wood Skin	TS72448WSF	456	Wood To The Flr Skin
TS71996TSSC	371	Sarto Top Cap Screen	TS72430WSF	456	Wood To The Flr Skin	TS72454TFGR	366	Frameless Glass
TS71996TUSC	371	Univ Top Cap Screen	TS72436GS	466	Back Ptd Gls Skin	TS72460GS	466	Back Ptd Gls Skin
TS71SGX	484	15-Amp Duplex Rcpt	TS72436GSF	468	Bck Ptd Gls to Flr Skn	TS72460GSF	468	Back Ptd Gls Flr Skin
TS71SGY	484	15-Amp Duplex Rcpt	TS72436HS	443	Steel Pnl Skin	TS72460HS	443	Steel Pnl Skin
TS71SGZ	484	15-Amp Duplex Rcpt	TS72436HSF	445	Steel To The Flr Skin	TS72460HSF	445	Steel To The Flr Skin
TS71SSX	484	15-Amp Duplex Rcpt	TS72436LS	452	Lam Skin	TS72460MB	448	Mkd Skin
TS71SSY	484	15-Amp Duplex Rcpt	TS72436LSF	453	Lam The Flr Skin	TS72460MBF	449	Mkd to the Floor Skin
TS71SSZ	484	15-Amp Duplex Rcpt	TS72436MB	448	Mkd Skin	TS72460SCW	476	Sgl-Pane Gls Win Kit
TS71USBX	485	USB Receptacle	TS72436MBF	449	Mkd to the Floor Skin	TS72460SPW	475	Sgl-Pane Gls Win
TS71USBY	485	USB Receptacle	TS72436MBS	447	Mkd Surf for Steel Skin	TS72460TA	436	F-Cvrd Pnl Skin
TS71USBZ	485	USB Receptacle	TS72436SBP	451	SW Skin Brace Pkg	TS72460TAF	438	F-Cvrd To The Flr Skin
TS720WSP	552	U Support Plate	TS72436SCW	476	Sgl-Pane Gls Win Kit	TS72460TFGR	366	Frameless Glass
TS72418GS	466	Back Ptd Gls Skin	TS72436SPW	475	Sgl-Pane Glass Win	TS72460TK	436	F-Cvrd Pnl Skin
TS72418GSF	468	Back Ptd Gls Flr Sk	TS72436SW	450	Slatwall Skin	TS72460TKF	438	F-Cvrd To The Flr Skin
TS72418HS	443	Steel Pnl Skin	TS72436TA	436	F-Cvrd Pnl Skin	TS72466TFGR	366	Frameless Glass
TS72418HSF	445	Steel To The Flr Skin	TS72436TAF	438	F-Cvrd The Flr Skin	TS72472GS	466	Bk Ptd Gls Skin
TS72418MB	448	MB Surf Pnl Bldps	TS72436TFGR	366	Frameless Glass	TS72472GSF	468	Bk Ptd Gls to Flr Skin
TS72418MBF	449	MB to the Floor Skin	TS72436TK	436	F-Cvrd Pnl Skin	TS72472HS	443	Steel Pnl Skin
TS72418TA	436	F-Cvrd Pnl Skin	TS72436TKF	438	F-Cvrd The Flr Skin	TS72472HSF	445	Steel To Flr Skin
TS72418TAF	438	F-Cvrd Pnl Skin	TS72436WS	454	Wood Skin	TS72472MB	448	Mkd Skin
TS72418TK	436	F-Cvrd Pnl Skin	TS72436WSF	456	Wood To The Flr Skin	TS72472MBF	449	Mkd to the Floor Skin
TS72418TKF	438	F-Cvrd To The Flr Skin	TS72442GS	466	Bk Ptd Gls Skin	TS72472SCW	476	Sgl-Pane Gls Win Kit
TS72424GS	466	Back Ptd Gls Skin	TS72442GSF	468	Bk Ptd Gls Flr Skin	TS72472SPW	475	Sgl-Pane Glass Win
TS72424GSF	468	Bck Ptd Glas Flr Skin	TS72442HS	443	Steel Pnl Skin	TS72472TA	436	F-Cvrd Pnl Skin
TS72424HS	443	Steel Pnl Skin	TS72442HSF	445	Steel To The Flr Skin	TS72472TAF	438	F-Cvrd To The Flr Skin
TS72424HSF	445	Steel To The Flr Skin	TS72442LS	452	Lam Skin	TS72472TFGR	366	Frameless Glass
TS72424LS	452	Lam Skin	TS72442LSF	453	Lam The Flr Skin	TS72472TK	436	F-Cvrd Pnl Skin
TS72424LSF	453	Lam To The Flr Skin	TS72442MB	448	Mkd Skin	TS72472TKF	438	F-Cvrd To The Flr Skin
TS72424MB	448	MB Skin	TS72442MBF	449	Mkd to the Floor Skin	TS72478SCW	476	Sgl-Pane Gls Win Kit
TS72424MBF	449	MB to the Floor Skin	TS72442MBS	447	Mkd Surf for Steel Skin	TS72478SPW	475	Sgl-Pane Glass Win
TS72424MBS	447	MB Surf for Steel Skin	TS72442SBP	451	SW Skin Brace Pkg	TS72478TFGR	366	Frameless Glass
TS72424SBP	451	SW Skin Brace Pkg	TS72442SCW	476	Sgl-Pane Gls Win Kit	TS72484SCW	476	Sgl-Pane Gls Win Kit
TS72424SCW	476	Sgl-Pane Gls Win Kit	TS72442SPW	475	Sgl-Pane Gls Win	TS72484SPW	475	Sgl-Pane Glass Win
TS72424SPW	475	Sgl-Pane Glass Win	TS72442SW	450	Slatwall Skin	TS72484TFGR	366	Frameless Glass
TS72424SW	450	Slatwall Skin	TS72442TA	436	F-Cvrd Pnl Skin	TS72490SCW	476	Sgl-Pane Gls Win Kit
TS72424TA	436	F-Cvrd Pnl Skin	TS72442TAF	438	F-Cvrd The Flr Skin	TS72490SPW	475	Sgl-Pane Glass Win
TS72424TAF	438	F-Cvrd To Flr Skin	TS72442TFGR	366	Frameless Glass	TS72490TFGR	366	Frameless Glass
TS72424TFGR	366	Frameless Glass	TS72442TK	436	F-Cvrd Pnl Skin	TS72496SCW	476	Sgl-Pane Gls Win Kit
TS72424TK	436	F-Cvrd Pnl Skin	TS72442TKF	438	F-Cvrd The Flr Skin	TS72496SPW	475	Sgl-Pane Glass Win
TS72424TKF	438	F-Cvrd The Flr Skin	TS72442WS	454	Wood Skin	TS72496TFGR	366	Frameless Glass
TS72424WS	454	Wood Skin	TS72442WSF	456	Wood To The Flr Skin	TS724BK	344, 412	Off-Mod Pnl Conn
TS72424WSF	456	Wood To The Flr Skin	TS72448GS	466	Bk Pntd Gls Skin	TS724BT	399	Base Trim
TS72430GS	466	Back Ptd Gls Skin	TS72448GSF	468	Bk Ptd Glass Flr Skin	TS724BTH	479	Hardwire Base Trim

Style Number Index, continued

Style Number	Page	Description	Style Number	Page	Description	Style Number	Page	Description
TS724CH	425	C-O-H Trim	TS73024GS	466	Bk Ptd Gls Skin	TS73048LSF	453	Lam To The Flr Skin
TS724CHS	425	C-O-H Trim	TS73024GSF	468	Bk Ptd Gls to Flr Skin	TS73048MB	448	Mkd Skin
TS724CHST	426	Stacking C-O-H Trim	TS73024HS	443	Steel Pnl Skin	TS73048MBF	449	Mkd to the Floor Skin
TS724CHT	426	Stacking C-O-H Trim	TS73024HSF	445	Steel To The Flr Skin	TS73048TA	436	F-Cvrd Pnl Skin
TS724CT	481	Cable Tray	TS73024LS	452	Lam Skin	TS73048TAF	438	F-Cvrd To The Flr Skin
TS724EPJS	415	Stck EOR Pnl Jct	TS73024LSF	453	Lam To The Flr Skin	TS73048TK	436	F-Cvrd Pnl Skin
TS724HF	430	Base Horz Frame Pkg	TS73024MB	448	Mkd Skin	TS73048TKF	438	F-Cvrd To The Flr Skin
TS724HFS	362, 431	Stck Horz Frame Pkg	TS73024MBF	449	Mkd to the Floor Skin	TS73048WS	454	Wood Skin
TS724HSBOB	446	Stl Pnl Skn B O Base	TS73024TA	436	F-Cvrd Pnl Skin	TS73048WSF	456	Wood To The Flr Skin
TS724IPJS	345, 413	Stck In-Line Pnl Jct	TS73024TAF	438	F-Cvrd To The Flr Skin	TS73060GS	466	Bk Ptd Glass Skin
TS724LPJS	414	Stacking L Pnl Jct	TS73024TK	436	F-Cvrd Pnl Skin	TS73060GSF	468	Bk Ptd Gls to Flr Skin
TS724OBK	399	Open Base Conv Kit	TS73024TKF	438	F-Cvrd To The Flr Skin	TS73060HS	443	Steel Pnl Skin
TS724SCH	424	C-O-H Trim	TS73024WS	454	Wood Skin	TS73060HSF	445	Steel To The Flr Skin
TS724SCHS	424	C-O-H Trim	TS73024WSF	456	Wood To The Flr Skin	TS73060MB	448	Mkd Skin
TS724SHF	429	Base Horz Frame Pkg	TS73030GS	466	Bk Ptd Glass Skin	TS73060MBF	449	Mkd to the Floor Skin
TS724T120CHT	355	120° Cnr C-O-H Trim	TS73030GSF	468	Bk Ptd Gls to Flr Skin	TS73060TA	436	F-Cvrd Pnl Skin
TS724T120CHTW	355	120° Cnr C-O-H Trim	TS73030HS	443	Steel Pnl Skin	TS73060TAF	438	F-Cvrd To The Flr Skin
TS724TCLCHT	354	L Cnr C-O-H Trim	TS73030HSF	445	Steel To The Flr Skin	TS73060TK	436	F-Cvrd Pnl Skin
TS724TCLCHTW	354	L Cnr C-O-H Trim	TS73030LS	452	Lam Skin	TS73060TKF	438	F-Cvrd To The Flr Skin
TS724TCTCHT	354	T Cnr C-O-H Trim	TS73030LSF	453	Lam To The Flr Skin	TS73072GS	466	Bk Ptd Glass Skin
TS724TCTCHTW	354	T Cnr C-O-H Trim	TS73030MB	448	Mkd Skin	TS73072GSF	468	Bk Ptd Gls to Flr Skin
TS724TEPJS	345	Stck EOR Pnl Jct	TS73030MBF	449	Mkd to the Floor Skin	TS73072HS	443	Steel Pnl Skin
TS724THF	361	Base Horz Frame Pkg	TS73030TA	436	F-Cvrd Pnl Skin	TS73072HSF	445	Steel To The Flr Skin
TS724TICHT	353	EOR In-Line COH Trim	TS73030TAF	438	F-Cvrd To The Flr Skin	TS73072MB	448	Mkd Skin
TS724TICHTW	353	EOR In-Line COH Trim	TS73030TK	436	F-Cvrd Pnl Skin	TS73072MBF	449	Mkd to the Floor Skin
TS724TKBOB	440	Fb Cvd Pnl S B O Bs	TS73030TKF	438	F-Cvrd To The Flr Skin	TS73072TA	436	F-Cvrd Pnl Skin
TS724TLPJS	346	Stacking L Pnl Jct	TS73030TKF	438	F-Cvrd To The Flr Skin	TS73072TAF	438	F-Cvrd To The Flr Skin
TS724TPJS	414	Stacking T Pnl Jct	TS73030WS	454	Wood Skin	TS73072TAF	436	F-Cvrd Pnl Skin
TS724TTPJS	346	Stacking T Pnl Jct	TS73030WSF	456	Wood To The Flr Skin	TS73072TK	436	F-Cvrd Pnl Skin
TS724TVCHT	355	V Cnr C-O-H Trim	TS73036GS	466	Bk Ptd Glass Skin	TS73072TKF	438	F-Cvrd To The Flr Skin
TS724TVCHTW	355	V Cnr C-O-H Trim	TS73036GSF	468	Bk Ptd Gls to Flr Skin	TS730BKT	344, 412	Off-Mod Pnl Conn
TS724TVPJS	346	Stacking V Pnl Jct	TS73036HS	443	Steel Pnl Skin	TS730BT	399	Base Trim
TS724UPHX	492	Mpp Power Infeed	TS73036HSF	445	Steel To The Flr Skin	TS730BTH	479	Hardwire Base Trim
TS724UPHXN	492	Mpp Power Infeed	TS73036LS	452	Lam Skin	TS730CH	425	C-O-H Trim
TS724UPHY	492	Mpp Power Infeed	TS73036LSF	453	Lam To The Flr Skin	TS730CHS	425	C-O-H Trim
TS724UPHYN	492	Mpp Power Infeed	TS73036MB	448	Mkd Skin	TS730CT	481	Cable Tray
TS724UPHZ	492	Mpp Power Infeed	TS73036MBF	449	Mkd to the Floor Skin	TS730EPJ	407	EOR Base Pnl Jct
TS724UPHZN	492	Mpp Power Infeed	TS73036TA	436	F-Cvrd Pnl Skin	TS730HF	430	Base Horz Frame Pkg
TS724VPJS	416	Stacking V Pnl Jct	TS73036TAF	438	F-Cvrd To The Flr Skin	TS730HFS	362, 431	Stck Horz Frame Pkg
TS724WPJS	345, 417	Stacking Wall-Start Jct	TS73036TK	436	F-Cvrd Pnl Skin	TS730HSBOB	446	Stl Pnl Skn B O Base
TS724XPJS	346, 414	Stacking X Pnl Jct	TS73036TKF	438	F-Cvrd To The Flr Skin	TS730IPJ	403	In-Line Base Pnl Jct
TS724YPJS	346, 416	Stacking Y Pnl Jct	TS73036WS	454	Wood Skin	TS730JP	356	Jct Post
TS72SGX	484	15-Amp Duplex Rcpt	TS73036WSF	456	Wood To The Flr Skin	TS730LPJ	405	L Base Pnl Jct
TS72SGY	484	15-Amp Duplex Rcpt	TS73042GS	466	Bk Ptd Glass Skin	TS730OBK	399	Open Base Conv Kit
TS72SGZ	484	15-Amp Duplex Rcpt	TS73042GSF	468	Bk Ptd Gls to Flr Skin	TS730SCH	424	C-O-H Trim
TS72SSX	484	15-Amp Duplex Rcpt	TS73042HS	443	Steel Pnl Skin	TS730SCHS	424	C-O-H Trim
TS72SSY	484	15-Amp Duplex Rcpt	TS73042HSF	445	Steel To The Flr Skin	TS730SEPJ	406	EOR Base Pnl Jct
TS72SSZ	484	15-Amp Duplex Rcpt	TS73042LS	452	Lam Skin	TS730SHF	429	Base Horz Frame Pkg
TS72USBX	485	USB Receptacle	TS73042LSF	453	Lam To The Flr Skin	TS730SIPJ	402	In-Line Base Pnl Jct
TS72USBY	485	USB Receptacle	TS73042MB	448	Mkd Skin	TS730SLPJ	404	L Base Pnl Jct
TS72USBZ	485	USB Receptacle	TS73042MBF	449	Mkd to the Floor Skin	TS730SSUC	420	Clg-Acs Lay-In Ut Pkg
TS73018GS	466	Bk Ptd Gls Skin	TS73042TA	436	F-Cvrd Pnl Skin	TS730SSUF	422	Flr-Acs Lay-In Util Pkg
TS73018GSF	468	Bk Ptd Gls to Flr Skin	TS73042TAF	438	F-Cvrd To The Flr Skin	TS730STPJ	404	T Base Pnl Jct
TS73018HS	443	Steel Pnl Skin	TS73042TK	436	F-Cvrd Pnl Skin	TS730SUC	421	Clg-Acs Lay-In Ut Pkg
TS73018HSF	445	Steel To The Flr Skin	TS73042TKF	438	F-Cvrd To The Flr Skin	TS730SUF	423	Flr-Acs Lay-In Util Pkg
TS73018MB	448	Mkd Surf for Pnl Bldps	TS73042WS	454	Wood Skin	TS730SVPJ	408	V Base Pnl Jct
TS73018MBF	449	Mkd to the Floor Skin	TS73042WSF	456	Wood To The Flr Skin	TS730SXPJ	404	X Base Pnl Jct
TS73018TA	436	F-Cvrd Pnl Skin	TS73048GS	466	Bk Ptd Glass Skin	TS730SYPJ	408	Y Base Pnl Jct
TS73018TAF	438	F-Cvrd To The Flr Skin	TS73048GSF	468	Bk Ptd Gls to Flr Skin	TS730T120CHT	355	120° Cnr C-O-H Trim
TS73018TK	436	F-Cvrd Pnl Skin	TS73048HS	443	Steel Pnl Skin	TS730T120CHTW	355	120° Cnr C-O-H Trim
TS73018TKF	438	F-Cvrd To The Flr Skin	TS73048HSF	445	Steel To The Flr Skin	TS730TCLCHT	354	L Cnr C-O-H Trim
TS73018TKF	438	F-Cvrd To The Flr Skin	TS73048LS	452	Lam Skin	TS730TCLCHTW	354	L Cnr C-O-H Trim

Style Number	Page	Description	Style Number	Page	Description	Style Number	Page	Description
TS730TCTCHT	354	T Cnr C-O-H Trim	TS73388TCXJW	335	X C-O-H Jct	TS73630LSF	453	Lam To The Flr Skin
TS730TCTCHTW	354	T Cnr C-O-H Trim	TS73388TCTJ	332	T C-O-H Jct	TS73630MB	448	Mkd Skin
TS730TEPJ	325	EOR Base Pnl Jct	TS73388TCTJW	332	T C-O-H Jct	TS73630MBF	449	Mkd to the Floor Skin
TS730TEPJW	325	EOR Base Pnl Jct	TS73388TCXJ	335	X C-O-H Jct	TS73630MBS	447	Mkd Surf for Steel Skin
TS730TEVT	350	EOR Vrtl Trim	TS73388TCXJW	335	X C-O-H Jct	TS73630TA	437	F-Cvrd Pnl Skin
TS730TEVTW	350	EOR Vrtl Trim	TS73388TCTJ	332	T C-O-H Jct	TS73630TAF	438	F-Cvrd To The Flr Skin
TS730THF	361	Base Horz Frame Pkg	TS73388TCTJW	332	T C-O-H Jct	TS73630TK	437	F-Cvrd Pnl Skin
TS730TICHT	353	EOR In-Line COH Trim	TS73434TCXJ	334	X C-O-H Jct	TS73630TKF	438	F-Cvrd To The Flr Skin
TS730TICHTW	353	EOR In-Line COH Trim	TS73434TCXJW	334	X C-O-H Jct	TS73630WS	455	Wood Skin
TS730TIPJ	322	In-Line Base Pnl Jct	TS73434TCTJ	330	T C-O-H Jct	TS73630WSF	457	Wood To The Flr Skin
TS730TKBOB	440	Fb Cvd Pnl S B O Bs	TS73434TCTJW	330	T C-O-H Jct	TS73636GS	467	Bk Ptd Gls Skin
TS730TLPJ	323	L Base Pnl Jct	TS73444TCYJ	341	Y C-O-H Jct	TS73636GSF	468	Bk Ptd Gls to Flr Skin
TS730TLPJW	323	L Base Pnl Jct	TS73444TCYJW	341	Y C-O-H Jct	TS73636HS	443	Steel Pnl Skin
TS730TLVT	351	L Vrtl Trim	TS73444TCYJ	327	In-Line C-O-H Jct	TS73636HSF	445	Steel To The Flr Skin
TS730TLVTW	351	L Vrtl Trim	TS73444TCYJW	327	In-Line C-O-H Jct	TS73636LS	452	Lam Skin
TS730TPJ	405	T Base Pnl Jct	TS73444TCYJ	327	In-Line C-O-H Jct	TS73636LSF	453	Lam To The Flr Skin
TS730TSUC	348	Clg-Acs Lay-in Ut Pkg	TS73444TCYJW	327	In-Line C-O-H Jct	TS73636MB	448	Mkd Skin
TS730TSUF	349	Flr-Acs Lay-in Util Pkg	TS73444TCYJ	338	V C-O-H Jct	TS73636MBF	449	Mkd to the Floor Skin
TS730TTCR	373	T C & Algnr Pkg – Ptd	TS73444TCYJW	338	V C-O-H Jct	TS73636MBS	447	Mkd Surf for Steel Skin
TS730TTCRWR	373	T C & Algnr Pkg – Wd	TS73444TCYJ	334	X C-O-H Jct	TS73636TA	437	F-Cvrd Pnl Skin
TS730TTPJ	323	T Base Pnl Jct	TS73444TCYJW	334	X C-O-H Jct	TS73636TAF	438	F-Cvrd To The Flr Skin
TS730TTPJW	323	T Base Pnl Jct	TS73444TCYJ	330	T C-O-H Jct	TS73636TCXJ	334	X C-O-H Jct
TS730TTVT	351	T Vrtl Trim	TS73444TCYJW	330	T C-O-H Jct	TS73636TCXJW	334	X C-O-H Jct
TS730TTVTW	351	T Vrtl Trim	TS73444TCYJ	341	Y C-O-H Jct	TS73636TKF	437	F-Cvrd Pnl Skin
TS730TVCHT	355	V Cnr C-O-H Trim	TS73444TCYJW	341	Y C-O-H Jct	TS73636TKF	438	F-Cvrd To The Flr Skin
TS730TVCHTW	355	V Cnr C-O-H Trim	TS73444TCYJ	327	In-Line C-O-H Jct	TS73636WS	455	Wood Skin
TS730VVPJ	326	V Base Pnl Jct	TS73444TCYJW	327	In-Line C-O-H Jct	TS73636WSF	457	Wood To The Flr Skin
TS730VVPJW	326	V Base Pnl Jct	TS73444TCYJ	328	L C-O-H Jct	TS73636TCTJ	330	T C-O-H Jct
TS730TVVT	352	V Vrtl Trim	TS73444TCYJW	328	L C-O-H Jct	TS73636TCTJW	330	T C-O-H Jct
TS730TVVTW	352	V Vrtl Trim	TS73444TCYJ	338	V C-O-H Jct	TS73642GS	467	Bk Ptd Gls Skin
TS730TXPJ	324	X Base Pnl Jct	TS73444TCYJW	338	V C-O-H Jct	TS73642GSF	468	Bk Ptd Gls to Flr Skin
TS730TXPJW	324	X Base Pnl Jct	TS73444TCYJ	338	V C-O-H Jct	TS73642HS	443	Steel Pnl Skin
TS730TYPJ	326	Y Base Pnl Jct	TS73444TCYJW	467	Bk Ptd Gls Skin	TS73642HSF	445	Steel To The Flr Skin
TS730TYPJW	326	Y Base Pnl Jct	TS73444TCYJ	468	Bk Ptd Gls to Flr Skin	TS73642LS	452	Lam Skin
TS730VPJ	409	V Base Pnl Jct	TS73444TCYJW	443	Steel Pnl Skin	TS73642LSF	453	Lam To The Flr Skin
TS730WPJ	342	Wall-Start Jct	TS73444TCYJ	445	Steel To The Flr Skin	TS73642MB	448	Mkd Skin
TS730XPJ	405	X Base Pnl Jct	TS73444TCYJW	448	Mkd Surf for Pnl Bldps	TS73642MBF	449	Mkd to the Floor Skin
TS730YPJ	409	Y Base Pnl Jct	TS73444TCYJ	449	Mkd to the Floor Skin	TS73642MBS	447	Mkd Surf for Steel Skin
TS73334TCXJ	336	X C-O-H Jct	TS73444TCYJW	437	F-Cvrd Pnl Skin	TS73642TA	437	F-Cvrd Pnl Skin
TS73334TCXJW	336	X C-O-H Jct	TS73444TCYJ	438	F-Cvrd To The Flr Skin	TS73642TAF	438	F-Cvrd To The Flr Skin
TS73335TCXJ	336	X C-O-H Jct	TS73444TCYJW	437	F-Cvrd Pnl Skin	TS73642TK	437	F-Cvrd Pnl Skin
TS73335TCXJW	336	X C-O-H Jct	TS73444TCYJ	438	F-Cvrd To The Flr Skin	TS73642TKF	438	F-Cvrd To The Flr Skin
TS73336TCXJ	336	X C-O-H Jct	TS73444TCYJW	467	Bk Ptd Gls Skin	TS73642TKF	438	F-Cvrd To The Flr Skin
TS73336TCXJW	336	X C-O-H Jct	TS73444TCYJ	468	Bk Ptd Gls to Flr Skin	TS73642WS	455	Wood Skin
TS73338TCXJ	336	X C-O-H Jct	TS73444TCYJW	443	Steel Pnl Skin	TS73642WSF	457	Wood To The Flr Skin
TS73338TCXJW	336	X C-O-H Jct	TS73444TCYJ	445	Steel To The Flr Skin	TS73648GS	467	Bk Ptd Glass Skin
TS73338TCXJW	336	X C-O-H Jct	TS73444TCYJW	452	Lam Skin	TS73648GSF	468	Bk Ptd Gls to Flr Skin
TS73338TCXJW	336	X C-O-H Jct	TS73444TCYJ	452	Lam Skin	TS73648HS	443	Steel Pnl Skin
TS73338TCXJW	336	X C-O-H Jct	TS73444TCYJW	453	Lam To The Flr Skin	TS73648HSF	445	Steel To The Flr Skin
TS73338TCXJW	336	X C-O-H Jct	TS73444TCYJ	448	Mkd Skin	TS73648HSF	445	Steel To The Flr Skin
TS73338TCXJW	336	X C-O-H Jct	TS73444TCYJW	449	Mkd to the Floor Skin	TS73648LS	452	Lam Skin
TS73338TCXJW	336	X C-O-H Jct	TS73444TCYJ	447	Mkd Surf for St Skin	TS73648LSF	453	Lam To The Flr Skin
TS73338TCXJW	336	X C-O-H Jct	TS73444TCYJW	437	F-Cvrd Pnl Skin	TS73648MB	448	Mkd Skin
TS73338TCXJW	336	X C-O-H Jct	TS73444TCYJ	438	F-Cvrd To The Flr Skin	TS73648MBF	449	Mkd to the Floor Skin
TS73338TCXJW	336	X C-O-H Jct	TS73444TCYJW	437	F-Cvrd Pnl Skin	TS73648MBS	447	Mkd Surf for Steel Skin
TS73338TCXJW	336	X C-O-H Jct	TS73444TCYJ	438	F-Cvrd To The Flr Skin	TS73648TA	437	F-Cvrd Pnl Skin
TS73338TCXJW	336	X C-O-H Jct	TS73444TCYJW	438	F-Cvrd To The Flr Skin	TS73648TAF	438	F-Cvrd To The Flr Skin
TS73338TCXJW	336	X C-O-H Jct	TS73444TCYJ	455	Wood Skin	TS73648TK	437	F-Cvrd Pnl Skin
TS73338TCXJW	336	X C-O-H Jct	TS73444TCYJW	457	Wood To The Flr Skin	TS73648TKF	438	F-Cvrd To The Flr Skin
TS73338TCXJW	336	X C-O-H Jct	TS73444TCYJ	467	Bk Ptd Glass Skin	TS73648WS	455	Wood Skin
TS73338TCXJW	336	X C-O-H Jct	TS73444TCYJW	468	Bk Ptd Gls to Flr Skin	TS73648WSF	457	Wood To The Flr Skin
TS73338TCXJW	336	X C-O-H Jct	TS73444TCYJ	443	Steel Pnl Skin	TS73660GS	467	Bk Ptd Glass Skin
TS73338TCXJW	336	X C-O-H Jct	TS73444TCYJW	445	Steel To The Flr Skin	TS73660GSF	468	Bk Ptd Gls to Flr Skin
TS73338TCXJW	336	X C-O-H Jct	TS73444TCYJ	452	Lam Skin			

Style Number	Page	Description	Style Number	Page	Description	Style Number	Page	Description
TS74248WS	455	Wood Skin	TS742TTCWR	373	T C & Algnr Pkgs – Wd	TS74545TCXJW	334	X C-O-H Jct
TS74248WSF	457	Wood To The Flr Skin	TS742TTPJ	323	T Base Pnl Jct	TS7454TCTJ	330	T C-O-H Jct
TS74260TA	437	F-Cvrd Pnl Skin	TS742TTPJW	323	T Base Pnl Jct	TS7454TCTJW	330	T C-O-H Jct
TS74260TAF	439	F-Cvrd To The Flr Skin	TS742TTVT	351	T Vrtl Trim	TS7455TCYJ	341	Y C-O-H Jct
TS74260TK	437	F-Cvrd Pnl Skin	TS742TTVTW	351	T Vrtl Trim	TS7455TCYJW	341	Y C-O-H Jct
TS74260TKF	439	F-Cvrd To The Flr Skin	TS742TUP	419	T Jct w/Util Pole	TS745TCIJ	327	In-Line C-O-H Jct
TS74260TPF	375	Perf Tack Acst Pnl Pkg	TS742TVPJ	326	V Base Pnl Jct	TS745TCIJW	327	In-Line C-O-H Jct
TS74260TTF	375	Tack Acst Pnl Pkg	TS742TVPJW	326	V Base Pnl Jct	TS745TCLJ	328	L C-O-H Jct
TS74272TA	437	F-Cvrd Pnl Skin	TS742TVVT	352	V Vrtl Trim	TS745TCLJW	328	L C-O-H Jct
TS74272TAF	439	F-Cvrd To The Flr Skin	TS742TVVTW	352	V Vrtl Trim	TS745TCVJ	338	V C-O-H Jct
TS74272TK	437	F-Cvrd Pnl Skin	TS742TXPJ	324	X Base Pnl Jct	TS745TCVJW	338	V C-O-H Jct
TS74272TKF	439	F-Cvrd To The Flr Skin	TS742TXPJW	324	X Base Pnl Jct	TS74646TCXJ	334	X C-O-H Jct
TS74272TPF	375	Perf Tack Acst Pnl Pkg	TS742TYPJ	326	Y Base Pnl Jct	TS74646TCXJW	334	X C-O-H Jct
TS74272TTF	375	Tack Acst Pnl Pkg	TS742TYPJW	326	Y Base Pnl Jct	TS7464TCTJ	330	T C-O-H Jct
TS742BKT	344, 412	Off-Mod Pnl Conn	TS742VPJ	409	V Base Pnl Jct	TS7464TCTJW	330	T C-O-H Jct
TS742BT	399	Base Trim	TS742WPJ	342, 410	Wall-Start Jct	TS7466TCYJ	341	Y C-O-H Jct
TS742BTH	479	Hardwire Base Trim	TS742XPJ	405	X Base Pnl Jct	TS7466TCYJW	341	Y C-O-H Jct
TS742CT	481	Cable Tray	TS742YPJ	409	Y Base Pnl Jct	TS746TCIJ	327	In-Line C-O-H Jct
TS742EPJ	407	EOR Base Pnl Jct	TS7433TCYJ	340	Y C-O-H Jct	TS746TCIJW	327	In-Line C-O-H Jct
TS742ERUP	419	EOR Jct w/Util Pole	TS7433TCYJW	340	Y C-O-H Jct	TS746TCLJ	328	L C-O-H Jct
TS742HF	430	Base Horiz Frame Pkg	TS7434TCTJ	331	T C-O-H Jct	TS746TCLJW	328	L C-O-H Jct
TS742HFS	362, 431	Stcking Horiz Frm Pkg	TS7434TCTJW	331	T C-O-H Jct	TS746TCVJ	338	V C-O-H Jct
TS742HSBOB	446	Stl Pnl Skn B O Base	TS743MHX	493	Modular Harness	TS746TCVJW	338	V C-O-H Jct
TS742IPJ	403	In-Line Base Pnl Jct	TS743MHN	493	Modular Harness	TS74747TCXJ	334	X C-O-H Jct
TS742JP	356	Jct Post	TS743MHY	493	Modular Harness	TS74747TCXJW	334	X C-O-H Jct
TS742LPJ	405	L Base Pnl Jct	TS743MHYN	493	Modular Harness	TS7474TCTJ	330	T C-O-H Jct
TS742LUP	419	L/In-Line Jct w/Util Ple	TS743MHZ	493	Modular Harness	TS7474TCTJW	330	T C-O-H Jct
TS742OBK	399	Open Base Conv Kit	TS743MHZN	493	Modular Harness	TS7477TCYJ	341	Y C-O-H Jct
TS742SEPJ	406	EOR Base Pnl Jct	TS7443TCTJ	333	T C-O-H Jct	TS7477TCYJW	341	Y C-O-H Jct
TS742SERUP	418	EOR Jct w/Util Pole	TS7443TCTJW	333	T C-O-H Jct	TS747TCIJ	327	In-Line C-O-H Jct
TS742SHF	429	Base Horiz Frame Pkg	TS74443TCXJ	337	X C-O-H Jct	TS747TCIJW	327	In-Line C-O-H Jct
TS742SIPJ	402	In-Line Base Pnl Jct	TS74443TCXJW	337	X C-O-H Jct	TS747TCLJ	328	L C-O-H Jct
TS742SLPJ	404	L Base Pnl Jct	TS74445TCXJ	336	X C-O-H Jct	TS747TCLJW	328	L C-O-H Jct
TS742SLUP	418	L/In-Line Jct w/Util Pl	TS74445TCXJW	336	X C-O-H Jct	TS747TCVJ	338	V C-O-H Jct
TS742SSUC	420	Clg-Acs Lay-In Utl Pkg	TS74446TCXJ	336	X C-O-H Jct	TS747TCVJW	338	V C-O-H Jct
TS742SSUF	422	Flr-Acs Lay-In Utl Pkg	TS74446TCXJW	336	X C-O-H Jct	TS74818TA	437	F-Cvrd Pnl Skin
TS742STC	432	Spanning Top Cap	TS74447TCXJ	336	X C-O-H Jct	TS74818TAF	439	F-Cvrd To The Flr Skin
TS742STPJ	404	T Base Pnl Jct	TS74447TCXJW	336	X C-O-H Jct	TS74818TK	437	F-Cvrd Pnl Skin
TS742STUP	418	T Jct w/Util Pole	TS74448TCXJ	336	X C-O-H Jct	TS74818TKF	439	F-Cvrd To The Flr Skin
TS742SUC	421	Clg-Acs Lay-In Utl Pkg	TS74448TCXJW	336	X C-O-H Jct	TS74818TPF	375	Perf Tack Acst Pnl Pkg
TS742SUF	423	Flr-Acs Lay-In Utl Pkg	TS7444QTCXJ	337	X C-O-H Jct	TS74818TTF	375	Tack Acst Pnl Pkg
TS742SVPJ	408	V Base Pnl Jct	TS7444QTCXJW	337	X C-O-H Jct	TS74824AWSF	462	Wood To Flr Skin Set
TS742SXPJ	404	X Base Pnl Jct	TS74455TCXJ	335	X C-O-H Jct	TS74824AWSS	458	Wood Skin Set
TS742SYPJ	408	Y Base Pnl Jct	TS74455TCXJW	335	X C-O-H Jct	TS74824BWSF	462	Wood To Flr Skin Set
TS742TEPJ	325	EOR Base Pnl Jct	TS7445TCTJ	332	T C-O-H Jct	TS74824BWS	458	Wood Skin Set
TS742TEPJW	325	EOR Base Pnl Jct	TS7445TCTJW	332	T C-O-H Jct	TS74824LS	452	Lam Skin
TS742TEVT	350	EOR Vrtl Trim	TS74466TCXJ	335	X C-O-H Jct	TS74824LSF	453	Lam To The Flr Skin
TS742TEVTW	350	EOR Vrtl Trim	TS74466TCXJW	335	X C-O-H Jct	TS74824TA	437	F-Cvrd Pnl Skin
TS742THF	361	Base Horiz Frame Pkg	TS7446TCTJ	332	T C-O-H Jct	TS74824TAF	439	F-Cvrd To The Flr Skin
TS742TIPJ	322	In-Line Base Pnl Jct	TS7446TCTJW	332	T C-O-H Jct	TS74824TK	437	F-Cvrd Pnl Skin
TS742TKBOB	440	Fb Cvd Pnl S B O Bs	TS74477TCXJ	335	X C-O-H Jct	TS74824TKF	439	F-Cvrd To The Flr Skin
TS742TLPJ	323	L Base Pnl Jct	TS74477TCXJW	335	X C-O-H Jct	TS74824TPF	375	Perf Tack Acst Pnl Pkg
TS742TLPJW	323	L Base Pnl Jct	TS7447TCTJ	332	T C-O-H Jct	TS74824TTF	375	Tack Acst Pnl Pkg
TS742TLVT	351	L Vrtl Trim	TS7447TCTJW	332	T C-O-H Jct	TS74824WS	455	Wood Skin
TS742TLVTW	351	L Vrtl Trim	TS74488TCXJ	335	T C-O-H Jct	TS74824WSF	457	Wood To The Flr Skin
TS742TPJ	405	T Base Pnl Jct	TS74488TCXJW	335	X C-O-H Jct	TS74830AWSF	462	Wood To Flr Skin Set
TS742TSUC	348	Clg-Acs Lay-in Utl Pkg	TS7448TCTJ	332	T C-O-H Jct	TS74830AWSS	458	Wood Skin Set
TS742TSUF	349	Flr-Acs Lay-in Utl Pkg	TS7448TCTJW	332	T C-O-H Jct	TS74830BWSF	462	Wood To Flr Skin Set
TS742TTC	363	Spanning Top Cap	TS744QTCXJ	333	T C-O-H Jct	TS74830BWS	458	Wood Skin Set
TS742TTCR	373	T C & Algnr Pkgs – Ptd	TS744QTCTJ	333	T C-O-H Jct	TS74830LS	452	Lam Skin
TS742TTCW	363	Spanning Top Cap	TS74545TCXJ	334	X C-O-H Jct	TS74830LSF	453	Lam To Flr Skin

Resources

Style Number Index, continued

Style Number	Page	Description	Style Number	Page	Description	Style Number	Page	Description
TS74830TA	437	F-Cvrd Pnl Skin	TS74872TAF	439	F-Cvrd To The Flr Skin	TS748TTPJ	323	T Base Pnl Jct
TS74830TAF	439	F-Cvrd To The Flr Skin	TS74872TK	437	F-Cvrd Pnl Skin	TS748TTPJW	323	T Base Pnl Jct
TS74830TK	437	F-Cvrd Pnl Skin	TS74872TKF	439	F-Cvrd To The Flr Skin	TS748TTVT	351	T Vrtl Trim
TS74830TKF	439	F-Cvrd To The Flr Skin	TS74872TPF	375	Perf Tack Acst Pnl Pkg	TS748TTVTW	351	T Vrtl Trim
TS74830TPF	375	Perf Tack Acst Pnl Pkg	TS74872TTF	375	Tack Acst Pnl Pkg	TS748TUP	419	T Jct w/Util Pole
TS74830TTF	375	Tack Acst Pnl Pkg	TS7488TCYJ	341	Y C-O-H Jct	TS748TVPJ	326	V Base Pnl Jct
TS74830WS	455	Wood Skin	TS7488TCYJW	341	Y C-O-H Jct	TS748TVPJW	326	V Base Pnl Jct
TS74830WSF	457	Wood To The Flr Skin	TS748BKT	344, 412	Off-Mod Pnl Conntor	TS748TVVT	352	V Vrtl Trim
TS74836AWSF	462	Wood To Flr Skin Set	TS748BT	399	Base Trim	TS748TVVTW	352	V Vrtl Trim
TS74836AWSS	458	Wood Skin Set	TS748BTH	479	Hardwire Base Trim	TS748TXPJ	324	X Base Pnl Jct
TS74836BWSF	462	Wood To Flr Skin Set	TS748CT	481	Cable Tray	TS748TXPJW	324	X Base Pnl Jct
TS74836BWSS	458	Wood Skin Set	TS748EPJ	407	EOR Base Pnl Jct	TS748TYPJ	326	Y Base Pnl Jct
TS74836LS	452	Lam Skin	TS748ERUP	419	EOR Jct w/Util Pole	TS748TYPJW	326	Y Base Pnl Jct
TS74836LSF	453	Lam To The Flr Skin	TS748HF	430	Base Horiz Frame Pkg	TS748VPJ	409	V Base Pnl Jct
TS74836TA	437	F-Cvrd Pnl Skin	TS748HFS	362, 431	Stck Horiz Frame Pkg	TS748WPJ	342, 410	Wall-Start Jct
TS74836TAF	439	F-Cvrd To The Flr Skin	TS748HSBOB	446	Stl Pnl Skn B O Base	TS748XPJ	405	X Base Pnl Jct
TS74836TK	437	F-Cvrd Pnl Skin	TS748IPJ	403	In-Line Base Pnl Jct	TS748YPJ	409	Y Base Pnl Jct
TS74836TKF	439	F-Cvrd To The Flr Skin	TS748JP	356	Jct Post	TS748Q4TCTJ	331	T C-O-H Jct
TS74836TPF	375	Perf Tack Acst Pnl Pkg	TS748LNPJ	405	L Base Pnl Jct	TS748Q4TCTJW	331	T C-O-H Jct
TS74836TTF	375	Tack Acst Pnl Pkg	TS748LUP	419	L/In-Ln Jct w/Util Pole	TS748QQTCTYJ	340	Y C-O-H Jct
TS74836WS	455	Wood Skin	TS748OBK	399	Open Base Conv Kit	TS748QQTCTYJW	340	Y C-O-H Jct
TS74836WSF	457	Wood To The Flr Skin	TS748SEPJ	406	EOR Base Pnl Jct	TS748SGX	484	15-Amp Duplex Rcpt
TS74842AWSF	462	Wood To Flr Skin Set	TS748SERUP	418	EOR Jct w/Util Pole	TS748SGY	484	15-Amp Duplex Rcpt
TS74842AWSS	458	Wood Skin Set	TS748SHF	429	Base Horiz Frame Pkg	TS748SSX	484	15-Amp Duplex Rcpt
TS74842BWSF	462	Wood To Flr Skin Set	TS748SIPJ	402	In-Line Base Pnl Jct	TS748SSY	484	15-Amp Duplex Rcpt
TS74842BWSS	458	Wood Skin Set	TS748SLPJ	404	L Base Pnl Jct	TS748USBX	485	USB Receptacle
TS74842LS	452	Lam Skin	TS748SLUP	418	L/In-Ln Jct w/Util Pole	TS748USBY	485	USB Receptacle
TS74842LSF	453	Lam To The Flr Skin	TS748SSUC	420	C-A Lay-In Util Pkg	TS7533TCYJ	340	Y C-O-H Jct
TS74842TA	437	F-Cvrd Pnl Skin	TS748SSUF	422	F-A Lay-In Util Pkg	TS7533TCYJW	340	Y C-O-H Jct
TS74842TAF	439	F-Cvrd To The Flr Skin	TS748STC	432	Spanning Top Cap	TS7535TCTJ	331	T C-O-H Jct
TS74842TK	437	F-Cvrd Pnl Skin	TS748STPJ	404	T Base Pnl Jct	TS7535TCTJW	331	T C-O-H Jct
TS74842TKF	439	F-Cvrd To The Flr Skin	TS748STUP	418	T Jct w/Util Pole	TS75418TPF	375	Perf Tack Acst Pnl Pkg
TS74842TPF	375	Perf Tack Acst Pnl Pkg	TS748SUC	421	C-A Lay-In Util Pkg	TS75418TTF	375	Tack Acst Pnl Pkg
TS74842TTF	375	Tack Acst Pnl Pkg	TS748SUF	423	F-A Lay-In Util Pkg	TS75424AWSF	463	Wood To Flr Skin Set
TS74842WS	455	Wood Skin	TS748SVPJ	408	V Base Pnl Jct	TS75424AWSS	459	Wood Skin Set
TS74842WSF	457	Wood To The Flr Skin	TS748SXPJ	404	X Base Pnl Jct	TS75424BWSF	463	Wood To Flr Skin Set
TS74848AWSF	462	Wood To Flr Skin Set	TS748SYPJ	408	V Base Pnl Jct	TS75424BWSS	459	Wood Skin Set
TS74848AWSS	458	Wood Skin Set	TS748TCIJ	327	In-Line C-O-H Jct	TS75424CWSF	463	Wood To Flr Skin Set
TS74848BWSF	462	Wood To Flr Skin Set	TS748TCIJW	327	In-Line C-O-H Jct	TS75424CWSS	459	Wood Skin Set
TS74848BWSS	458	Wood Skin Set	TS748TCLJ	328	In-Line C-O-H Jct	TS75424TPF	375	Perf Tack Acst Pnl Pkg
TS74848LS	452	Lam Skin	TS748TCLJW	328	L C-O-H Jct	TS75424TTF	375	Tack Acst Pnl Pkg
TS74848LSF	453	Lam To The Flr Skin	TS748TCVJ	338	V C-O-H Jct	TS75430AWSF	463	Wood To Flr Skin Set
TS74848TA	437	F-Cvrd Pnl Skin	TS748TCVJW	338	V C-O-H Jct	TS75430AWSS	459	Wood Skin Set
TS74848TAF	439	F-Cvrd To The Flr Skin	TS748TEPJ	325	EOR Base Pnl Jct	TS75430BWSF	463	Wood To Flr Skin Set
TS74848TCXJ	334	X C-O-H Jct	TS748TEPJW	325	EOR Base Pnl Jct	TS75430BWSS	459	Wood Skin Set
TS74848TCXJW	334	X C-O-H Jct	TS748TEVT	350	EOR Vrtl Trim	TS75430CWSF	463	Wood To Flr Skin Set
TS74848TK	437	F-Cvrd Pnl Skin	TS748TEVTW	350	EOR Vrtl Trim	TS75430CWSS	459	Wood Skin Set
TS74848TKF	439	F-Cvrd To The Flr Skin	TS748THF	361	Base Horiz Frame Pkg	TS75430TPF	375	Perf Tack Acst Pnl Pkg
TS74848TPF	375	Perf Tack Acst Pnl Pkg	TS748TIPJ	322	In-Line Base Pnl Jct	TS75430TTF	375	Tack Acst Pnl Pkg
TS74848TTF	375	Tack Acst Pnl Pkg	TS748TKBOB	440	Fb Cvd Pnl S B O Bs	TS75436AWSF	463	Wood To Flr Skin Set
TS74848WS	455	Wood Skin	TS748TLPJ	323	L Base Pnl Jct	TS75436AWSS	459	Wood Skin Set
TS74848WSF	457	Wood To The Flr Skin	TS748TLPJW	323	L Base Pnl Jct	TS75436BWSF	463	Wood To Flr Skin Set
TS7484TCTJ	330	T C-O-H Jct	TS748TLVT	351	L Vrtl Trim	TS75436BWSS	459	Wood Skin Set
TS7484TCTJW	330	T C-O-H Jct	TS748TLVTW	351	L Vrtl Trim	TS75436CWSF	463	Wood To Flr Skin Set
TS74860TA	437	F-Cvrd Pnl Skin	TS748TPJ	405	T Base Pnl Jct	TS75436CWSS	459	Wood Skin Set
TS74860TAF	439	F-Cvrd To The Flr Skin	TS748TSUC	348	C-A Lay-in Util Pkg	TS75436TPF	375	Perf Tack Acst Pnl Pkg
TS74860TK	437	F-Cvrd Pnl Skin	TS748TSUF	349	F-A Lay-in Util Pkg	TS75436TTF	375	Tack Acst Pnl Pkg
TS74860TKF	439	F-Cvrd To The Flr Skin	TS748TTC	363	Spanning Top Cap	TS75442AWSF	463	Wood To Flr Skin Set
TS74860TPF	375	Perf Tack Acst Pnl Pkg	TS748TTCR	373	T C & Algr Pkg – Ptd	TS75442AWSS	459	Wood Skin Set
TS74860TTF	375	Tack Acst Pnl Pkg	TS748TTCW	363	Spanning Top Cap	TS75442BWSF	463	Wood To Flr Skin Set
TS74872TA	437	F-Cvrd Pnl Skin	TS748TTCWR	373	T C & Algr Pkg – Wd	TS75442BWSS	459	Wood Skin Set

Style Number	Page	Description	Style Number	Page	Description	Style Number	Page	Description
TS75442CWSF	463	Wood To Flr Skin Set	TS754TXPJW	324	X Base Pnl Jct	TS7588TCYJ	340	Y C-O-H Jct
TS75442CWSS	459	Wood Skin Set	TS754TYPJ	326	Y Base Pnl Jct	TS7588TCYJW	340	Y C-O-H Jct
TS75442TPF	375	Perf Tack Acst Pnl Pkg	TS754TYPJW	326	Y Base Pnl Jct	TS759TCIJ	327	In-Line C-O-H Jct
TS75442TTF	375	Tack Acst Pnl Pkg	TS754VPJ	409	V Base Pnl Jct	TS759TCIJW	327	In-Line C-O-H Jct
TS75448AWSF	463	Wood To Flr Skin Set	TS754WPJ	342, 410	Wall-Start Jct	TS759QTCYJ	331	T C-O-H Jct
TS75448AWSS	459	Wood Skin Set	TS754XPJ	405	X Base Pnl Jct	TS759QTCYJW	331	T C-O-H Jct
TS75448BWSF	463	Wood To Flr Skin Set	TS754YPJ	409	Y Base Pnl Jct	TS759QTCYJW	340	T C-O-H Jct
TS75448BWSS	459	Wood Skin Set	TS7553TCTJ	333	T C-O-H Jct	TS76018TA	437	F-Cvrd Pnl Skin
TS75448CWSF	463	Wood To Flr Skin Set	TS7553TCTJW	333	T C-O-H Jct	TS76018TAF	439	F-Cvrd To The Flr Skin
TS75448CWSS	459	Wood Skin Set	TS7554TCTJ	333	T C-O-H Jct	TS76018TK	437	F-Cvrd Pnl Skin
TS75448TPF	375	Perf Tack Acst Pnl Pkg	TS7554TCTJW	333	T C-O-H Jct	TS76018TKF	439	F-Cvrd To The Flr Skin
TS75448TTF	375	Tack Acst Pnl Pkg	TS75553TCXJ	337	X C-O-H Jct	TS76024LS	452	Lam Skin
TS7544TCYJ	340	Y C-O-H Jct	TS75553TCXJW	337	X C-O-H Jct	TS76024LSF	453	Lam To The Flr Skin
TS7544TCYJW	340	Y C-O-H Jct	TS75554TCXJ	337	X C-O-H Jct	TS76024TA	437	F-Cvrd Pnl Skin
TS7545TCTJ	331	T C-O-H Jct	TS75554TCXJW	337	X C-O-H Jct	TS76024TAF	439	F-Cvrd To The Flr Skin
TS7545TCTJW	331	T C-O-H Jct	TS75555TCXJ	336	X C-O-H Jct	TS76024TK	437	F-Cvrd Pnl Skin
TS75460TPF	375	Perf Tack Acst Pnl Pkg	TS75555TCXJW	336	X C-O-H Jct	TS76024TKF	439	F-Cvrd To The Flr Skin
TS75460TTF	375	Tack Acst Pnl Pkg	TS75557TCXJ	336	X C-O-H Jct	TS76024WS	455	Wood Skin
TS75472TPF	375	Perf Tack Acst Pnl Pkg	TS75557TCXJW	336	X C-O-H Jct	TS76024WSF	457	Wood To The Flr Skin
TS75472TTF	375	Tack Acst Pnl Pkg	TS75558TCXJ	337	X C-O-H Jct	TS76030LS	452	Lam Skin
TS754EPJ	407	EOR Base Pnl Jct	TS75558TCXJW	337	X C-O-H Jct	TS76030LSF	453	Lam To The Flr Skin
TS754ERUP	419	EOR Jct w/Util Pole	TS75559TCXJ	337	X C-O-H Jct	TS76030TA	437	F-Cvrd Pnl Skin
TS754ICLS	357	Inside Cnr Light Seal	TS75559TCXJW	337	X C-O-H Jct	TS76030TAF	439	F-Cvrd To The Flr Skin
TS754IPJ	403	In-Line Base Pnl Jct	TS75566TCXJ	335	X C-O-H Jct	TS76030TK	437	F-Cvrd Pnl Skin
TS754JP	356	Jct Post	TS75566TCXJW	335	X C-O-H Jct	TS76030TKF	439	F-Cvrd To The Flr Skin
TS754LPJ	405	L Base Pnl Jct	TS7556TCTJ	332	T C-O-H Jct	TS76030WS	455	Wood Skin
TS754LUP	419	L/In-Ln Jct w/Util Pole	TS7556TCTJW	332	T C-O-H Jct	TS76030WSF	457	Wood To The Flr Skin
TS754SEPJ	406	EOR Base Pnl Jct	TS75577TCXJ	335	X C-O-H Jct	TS76036LS	452	Lam Skin
TS754SERUP	418	EOR Jct w/Util Pole	TS75577TCXJW	335	X C-O-H Jct	TS76036LSF	453	Lam To The Flr Skin
TS754SIPJ	402	In-Line Base Pnl Jct	TS7557TCTJ	332	T C-O-H Jct	TS76036TA	437	F-Cvrd Pnl Skin
TS754SLPJ	404	L Base Pnl Jct	TS7557TCTJW	332	T C-O-H Jct	TS76036TAF	439	F-Cvrd To The Flr Skin
TS754SLUP	418	L/In-Ln Jct w/Util Pole	TS7558TCTJ	333	T C-O-H Jct	TS76036TK	437	F-Cvrd Pnl Skin
TS754STPJ	404	T Base Pnl Jct	TS7558TCTJW	333	T C-O-H Jct	TS76036TKF	439	F-Cvrd To The Flr Skin
TS754STUP	418	T Jct w/Util Pole	TS7559TCTJ	333	T C-O-H Jct	TS76036WS	455	Wood Skin
TS754SVPJ	408	V Base Pnl Jct	TS7559TCTJW	333	T C-O-H Jct	TS76036WSF	457	Wood To The Flr Skin
TS754SXPJ	404	X Base Pnl Jct	TS75656TCXJ	334	X C-O-H Jct	TS76042LS	452	Lam Skin
TS754SYPJ	408	Y Base Pnl Jct	TS75656TCXJW	334	X C-O-H Jct	TS76042LSF	453	Lam To The Flr Skin
TS754TEPJ	325	EOR Base Pnl Jct	TS7565TCTJ	330	T C-O-H Jct	TS76042TA	437	F-Cvrd Pnl Skin
TS754TEPJW	325	EOR Base Pnl Jct	TS7565TCTJW	330	T C-O-H Jct	TS76042TAF	439	F-Cvrd To The Flr Skin
TS754TEVT	350	EOR Vrtl Trim	TS7566TCYJ	341	Y C-O-H Jct	TS76042TK	437	F-Cvrd Pnl Skin
TS754TEVTW	350	EOR Vrtl Trim	TS7566TCYJW	341	Y C-O-H Jct	TS76042TKF	439	F-Cvrd To The Flr Skin
TS754TIPJ	322	In-Line Base Pnl Jct	TS756TCIJ	327	In-Line C-O-H Jct	TS76042WS	455	Wood Skin
TS754TLPJ	323	L Base Pnl Jct	TS756TCIJW	327	In-Line C-O-H Jct	TS76042WSF	457	Wood To The Flr Skin
TS754TLPJW	323	L Base Pnl Jct	TS756TCLJ	328	L C-O-H Jct	TS76048LS	452	Lam Skin
TS754TLVT	351	L Vrtl Trim	TS756TCLJW	328	L C-O-H Jct	TS76048LSF	453	Lam To The Flr Skin
TS754TLVTW	351	L Vrtl Trim	TS756TCVJ	338	V C-O-H Jct	TS76048TA	437	F-Cvrd Pnl Skin
TS754TPJ	405	T Base Pnl Jct	TS756TCVJW	338	V C-O-H Jct	TS76048TAF	439	F-Cvrd To The Flr Skin
TS754TTC	363	Spanning Top Cap	TS75757TCXJ	334	X C-O-H Jct	TS76048TK	437	F-Cvrd Pnl Skin
TS754TTCR	373	T C & Algn Pkg – Ptd	TS75757TCXJW	334	X C-O-H Jct	TS76048TKF	439	F-Cvrd To The Flr Skin
TS754TTCW	363	Spanning Top Cap	TS7575TCTJ	330	T C-O-H Jct	TS76048WS	455	Wood Skin
TS754TTCWR	373	T C & Algn Pkg – Wd	TS7575TCTJW	330	T C-O-H Jct	TS76048WSF	457	Wood To The Flr Skin
TS754TTPJ	323	T Base Pnl Jct	TS7577TCYJ	341	Y C-O-H Jct	TS76060TA	437	F-Cvrd Pnl Skin
TS754TTPJW	323	T Base Pnl Jct	TS7577TCYJW	341	Y C-O-H Jct	TS76060TAF	439	F-Cvrd To The Flr Skin
TS754TTVT	351	T Vrtl Trim	TS757TCIJ	327	In-Line C-O-H Jct	TS76060TK	437	F-Cvrd Pnl Skin
TS754TTVTW	351	T Vrtl Trim	TS757TCIJW	327	In-Line C-O-H Jct	TS76060TKF	439	F-Cvrd To The Flr Skin
TS754TUP	419	T Jct w/Util Pole	TS757TCLJ	328	L C-O-H Jct	TS76072TA	437	F-Cvrd Pnl Skin
TS754TVPJ	326	V Base Pnl Jct	TS757TCLJW	328	L C-O-H Jct	TS76072TK	437	F-Cvrd Pnl Skin
TS754TVPJW	326	V Base Pnl Jct	TS757TCVJ	338	V C-O-H Jct	TS760BKT	344, 412	Off-Mod Pnl Connect
TS754TVVT	352	V Vrtl Trim	TS757TCVJW	338	V C-O-H Jct	TS760BT	399	Base Trim
TS754TVVTW	352	V Vrtl Trim	TS7585TCTJ	331	T C-O-H Jct	TS760BTH	479	Hardwire Base Trim
TS754TXPJ	324	X Base Pnl Jct	TS7585TCTJW	331	T C-O-H Jct			

Style Number Index, continued

Style Number	Page	Description
TS760CT	481	Cable Tray
TS760HF	430	Base Horiz Frame Pkg
TS760HFS	362, 431	Stacking Horiz Fr Pkg
TS760HSBOB	446	Stl Pnl Skn B O Base
TS760OBK	399	Open Base Conv Kit
TS760SHF	429	Base Horiz Frame Pkg
TS760STC	432	Spanning Top Cap
TS760TEVT	350	EOR Vrtl Trim
TS760TEVTW	350	EOR Vrtl Trim
TS760THF	361	Base Horiz Frame Pkg
TS760TKBOB	440	Fb Cvd Pnl S B O Bs
TS760TLVT	351	L Vrtl Trim
TS760TLVTW	351	L Vrtl Trim
TS760TTC	363	Spanning Top Cap
TS760TTCR	373	T C & Algn Pkg – Ptd
TS760TTCW	363	Spanning Top Cap
TS760TTCWR	373	T C & Algn Pkg – Wd
TS760TTVT	351	T Vrtl Trim
TS760TTVTW	351	T Vrtl Trim
TS760TVVT	352	V Vrtl Trim
TS760TVVTW	352	V Vrtl Trim
TS7624HS	471	Stl Tech Skin, No Co
TS7624TFGR	364	Frameless Glass
TS7624TSS	471	Steel Tech Skin
TS7630HS	471	Stl Tech Skin, No Co
TS7630LTSS	471	Stl Tech Skin, LH Co
TS7630RTSS	471	Stl Tech Skin, RH Co
TS7630TFGR	364	Frameless Glass
TS7630TSS	471	Steel Tech Skin
TS7633TCYJ	340	Y C-O-H Jct
TS7633TCYJW	340	Y C-O-H Jct
TS7636HS	471	Stl Tech Skin, No Co
TS7636LTSS	471	Stl Tech Skin, LH Co
TS7636RTSS	471	Stl Tech Skin, RH Co
TS7636TCTJ	331	T C-O-H Jct
TS7636TCTJW	331	T C-O-H Jct
TS7636TFGR	364	Frameless Glass
TS7636TSS	471	Steel Tech Skin
TS7642HS	471	Stl Tech Skin, No Co
TS7642LTSS	471	Stl Tech Skin, LH Co
TS7642RTSS	471	Stl Tech Skin, RH Co
TS7642TFGR	364	Frameless Glass
TS7642TSS	471	Steel Tech Skin
TS7644TCYJ	340	Y C-O-H Jct
TS7644TCYJW	340	Y C-O-H Jct
TS7646TCTJ	331	T C-O-H Jct
TS7646TCTJW	331	T C-O-H Jct
TS7648HS	471	Stl Tech Skin, No Co
TS7648LTSS	471	Stl Tech Skin, LH Co
TS7648RTSS	471	Stl Tech Skin, RH Co
TS7648TFGR	364	Frameless Glass
TS7648TSS	471	Steel Tech Skin
TS7654TFGR	364	Frameless Glass
TS7655TCYJ	340	Y C-O-H Jct
TS7655TCYJW	340	Y C-O-H Jct
TS7656TCTJ	331	T C-O-H Jct
TS7656TCTJW	331	T C-O-H Jct
TS7660HS	471	Stl Tech Skin, No Co
TS7660LTSS	471	Stl Tech Skin, LH Co
TS7660RTSS	471	Stl Tech Skin, RH Co
TS7660TFGR	364	Frameless Glass

Style Number	Page	Description
TS7660TSS	471	Steel Tech Skin
TS76618TPF	375	Perf Tack Acst Pnl Pkg
TS76618TTF	375	Tack Acst Pnl Pkg
TS76624AWSF	463	Wood To Flr Skin Set
TS76624AWSS	459	Wood Skin Set
TS76624BWSF	464	Wood To Flr Skin Set
TS76624BWSS	460	Wood Skin Set
TS76624CWSF	464	Wood To Flr Skin Set
TS76624CWSS	460	Wood Skin Set
TS76624TPF	375	Perf Tack Acst Pnl Pkg
TS76624TTF	375	Tack Acst Pnl Pkg
TS76630AWSF	463	Wood To Flr Skin Set
TS76630AWSS	459	Wood Skin Set
TS76630BWSF	464	Wood To Flr Skin Set
TS76630BWSS	460	Wood Skin Set
TS76630CWSF	464	Wood To Flr Skin Set
TS76630CWSS	460	Wood Skin Set
TS76630TPF	375	Perf Tack Acst Pnl Pkg
TS76630TTF	375	Tack Acst Pnl Pkg
TS76636AWSF	463	Wood To Flr Skin Set
TS76636AWSS	459	Wood Skin Set
TS76636BWSF	464	Wood To Flr Skin Set
TS76636BWSS	460	Wood Skin Set
TS76636CWSF	464	Wood To Flr Skin Set
TS76636CWSS	460	Wood Skin Set
TS76636TPF	375	Perf Tack Acst Pnl Pkg
TS76636TTF	375	Tack Acst Pnl Pkg
TS7663TCTJ	333	T C-O-H Jct
TS7663TCTJW	333	T C-O-H Jct
TS76642AWSF	463	Wood To Flr Skin Set
TS76642AWSS	459	Wood Skin Set
TS76642BWSF	464	Wood To Flr Skin Set
TS76642BWSS	460	Wood Skin Set
TS76642CWSF	464	Wood To Flr Skin Set
TS76642CWSS	460	Wood Skin Set
TS76642TPF	375	Perf Tack Acst Pnl Pkg
TS76642TTF	375	Tack Acst Pnl Pkg
TS76648AWSF	463	Wood To Flr Skin Set
TS76648AWSS	459	Wood Skin Set
TS76648BWSF	464	Wood To Flr Skin Set
TS76648BWSS	460	Wood Skin Set
TS76648CWSF	464	Wood To Flr Skin Set
TS76648CWSS	460	Wood Skin Set
TS76648TPF	375	Perf Tack Acst Pnl Pkg
TS76648TTF	375	Tack Acst Pnl Pkg
TS7664TCTJ	333	T C-O-H Jct
TS7664TCTJW	333	T C-O-H Jct
TS7665TCTJ	333	T C-O-H Jct
TS7665TCTJW	333	T C-O-H Jct
TS76660TPF	375	Perf Tack Acst Pnl Pkg
TS76660TTF	375	Tack Acst Pnl Pkg
TS76663TCXJ	337	X C-O-H Jct
TS76663TCXJW	337	X C-O-H Jct
TS76664TCXJ	337	X C-O-H Jct
TS76664TCXJW	337	X C-O-H Jct
TS76665TCXJ	337	X C-O-H Jct
TS76665TCXJW	337	X C-O-H Jct
TS76667TCXJ	336	X C-O-H Jct
TS76667TCXJW	336	X C-O-H Jct
TS76668TCXJ	337	X C-O-H Jct
TS76668TCXJW	337	X C-O-H Jct

Style Number	Page	Description
TS7666QTCXJ	337	X C-O-H Jct
TS7666QTCXJW	337	X C-O-H Jct
TS7666TFGR	364	Frameless Glass
TS76672TPF	375	Perf Tack Acst Pnl Pkg
TS76672TTF	375	Tack Acst Pnl Pkg
TS76677TCXJ	335	X C-O-H Jct
TS76677TCXJW	335	X C-O-H Jct
TS7667TCTJ	332	T C-O-H Jct
TS7667TCTJW	332	T C-O-H Jct
TS7668TCTJ	333	T C-O-H Jct
TS7668TCTJW	333	T C-O-H Jct
TS766EPJ	407	EOR Base Pnl Jct
TS766ERUP	419	EOR Jct w/Util Pole
TS766ICLS	357	Inside Cnr Light Seal
TS766IPJ	403	In-Line Base Pnl Jct
TS766JP	356	Jct Post
TS766LPJ	405	L Base Pnl Jct
TS766LUP	419	L/In-Ln Jct w/Util Pole
TS766QTCTJ	333	T C-O-H Jct
TS766QTCTJW	333	T C-O-H Jct
TS766SEPJ	406	EOR Base Pnl Jct
TS766SERUP	418	EOR Jct w/Util Pole
TS766SIPJ	402	In-Line Base Pnl Jct
TS766SLPJ	404	L Base Pnl Jct
TS766SLUP	418	L/In-Ln Jct w/Util Pole
TS766STPJ	404	T Base Pnl Jct
TS766STUP	418	T Jct w/Util Pole
TS766SVPJ	408	V Base Pnl Jct
TS766SXPJ	404	X Base Pnl Jct
TS766SYPJ	408	Y Base Pnl Jct
TS766TEPJ	325	EOR Base Pnl Jct
TS766TEPJW	325	EOR Base Pnl Jct
TS766TEVT	350	EOR Vrtl Trim
TS766TEVTW	350	EOR Vrtl Trim
TS766TIPJ	322	In-Line Base Pnl Jct
TS766TLPJ	323	L Base Pnl Jct
TS766TLPJW	323	L Base Pnl Jct
TS766TLVT	351	L Vrtl Trim
TS766TLVTW	351	L Vrtl Trim
TS766TPJ	405	T Base Pnl Jct
TS766TTC	363	Spanning Top Cap
TS766TTCR	373	T C & Algn Pkg – Ptd
TS766TTCW	363	Spanning Top Cap
TS766TTCWR	373	T C & Algn Pkg – Wd
TS766TTPJ	323	T Base Pnl Jct
TS766TTPJW	323	T Base Pnl Jct
TS766TTVT	351	T Vrtl Trim
TS766TTVTW	351	T Vrtl Trim
TS766TUP	419	T Jct w/Util Pole
TS766TVPJ	326	V Base Pnl Jct
TS766TVPJW	326	V Base Pnl Jct
TS766TVVT	352	V Vertical Trim
TS766TVVTW	352	V Vertical Trim
TS766TXPJ	324	X Base Pnl Jct
TS766TXPJW	324	X Base Pnl Jct
TS766TYPJ	326	Y Base Pnl Jct
TS766TYPJW	326	Y Base Pnl Jct
TS766VPJ	409	V Base Pnl Jct
TS766WPJ	342, 410	Wall-Start Jct
TS766XPJ	405	X Base Pnl Jct
TS766YPJ	409	Y Base Pnl Jct

Style Number Index, continued

Style Number	Page	Description
TS784TLVT	351	L Vrtl Trim
TS784TLVTW	351	L Vrtl Trim
TS784TTC	363	Spanning Top Cap
TS784TTCW	363	Spanning Top Cap
TS784TTVT	351	T Vrtl Trim
TS784TTVTW	351	T Vrtl Trim
TS784TVVT	352	V Vrtl Trim
TS784TVVTW	352	V Vrtl Trim
TS785TCYJ	341	Y C-O-H Jct
TS785TCYJW	341	Y C-O-H Jct
TS78585TCXJ	334	X C-O-H Jct
TS78585TCXJW	334	X C-O-H Jct
TS7858TCTJ	330	T C-O-H Jct
TS7858TCTJW	330	T C-O-H Jct
TS785TCIJ	327	In-Line C-O-H Jct
TS785TCIJW	327	In-Line C-O-H Jct
TS785TCLJ	328	L C-O-H Jct
TS785TCLJW	328	L C-O-H Jct
TS785TCVJ	338	V C-O-H Jct
TS785TCVJW	338	V C-O-H Jct
TS7866TCYJ	341	Y C-O-H Jct
TS7866TCYJW	341	Y C-O-H Jct
TS78686TCXJ	334	X C-O-H Jct
TS78686TCXJW	334	X C-O-H Jct
TS7868TCTJ	330	T C-O-H Jct
TS7868TCTJW	330	T C-O-H Jct
TS786TCIJ	327	In-Line C-O-H Jct
TS786TCIJW	327	In-Line C-O-H Jct
TS786TCLJ	328	L C-O-H Jct
TS786TCLJW	328	L C-O-H Jct
TS786TCVJ	338	V C-O-H Jct
TS786TCVJW	338	V C-O-H Jct
TS7877TCYJ	341	Y C-O-H Jct
TS7877TCYJW	341	Y C-O-H Jct
TS78787TCXJ	334	X C-O-H Jct
TS78787TCXJW	334	X C-O-H Jct
TS7878TCTJ	330	T C-O-H Jct
TS7878TCTJW	330	T C-O-H Jct
TS787TCLJ	328	L C-O-H Jct
TS787TCLJW	328	L C-O-H Jct
TS787TCVJ	338	V C-O-H Jct
TS787TCVJW	338	V C-O-H Jct
TS7883TCTJ	333	T C-O-H Jct
TS7883TCTJW	333	T C-O-H Jct
TS7884TCTJ	333	T C-O-H Jct
TS7884TCTJW	333	T C-O-H Jct
TS78855TCXJ	335	X C-O-H Jct
TS78855TCXJW	335	X C-O-H Jct
TS7885TCTJ	332	T C-O-H Jct
TS7885TCTJW	332	T C-O-H Jct
TS78866TCXJ	335	X C-O-H Jct
TS78866TCXJW	335	X C-O-H Jct
TS7886TCTJ	332	T C-O-H Jct
TS7886TCTJW	332	T C-O-H Jct
TS78877TCXJ	335	X C-O-H Jct
TS78877TCXJW	335	X C-O-H Jct
TS7887TCTJ	332	T C-O-H Jct
TS7887TCTJW	332	T C-O-H Jct
TS78883TCXJ	337	X C-O-H Jct
TS78883TCXJW	337	X C-O-H Jct
TS78884TCXJ	337	X C-O-H Jct

Style Number	Page	Description
TS78884TCXJW	337	X C-O-H Jct
TS78885TCXJ	336	X C-O-H Jct
TS78885TCXJW	336	X C-O-H Jct
TS78886TCXJ	336	X C-O-H Jct
TS78886TCXJW	336	X C-O-H Jct
TS78887TCXJ	336	X C-O-H Jct
TS78887TCXJW	336	X C-O-H Jct
TS7888QTCXJ	337	X C-O-H Jct
TS7888QTCXJW	337	X C-O-H Jct
TS788QTCTJ	333	T C-O-H Jct
TS788QTCTJW	333	T C-O-H Jct
TS788TCTJ	331	T C-O-H Jct
TS788TCTJW	331	T C-O-H Jct
TS788QTCTYJ	340	Y C-O-H Jct
TS788QTCTYJW	340	Y C-O-H Jct
TS790COHJC	358	90° C-O-H Jct Cap
TS790COHJCW	358	90° C-O-H Jct Cap
TS790JB3	357	90° Jct Block, Pkg of 3
TS790JB4	357	90° Jct Block, Pkg of 4
TS790JB5	357	90° Jct Block, Pkg of 5
TS790JC	358	90° Cnr Jct Cap
TS790JCW	358	90° Cnr Jct Cap
TS790STC	432	Spanning Top Cap
TS790TEVT	350	EOR Vrtl Trim
TS790TEVTW	350	EOR Vrtl Trim
TS790TLVT	351	L Vrtl Trim
TS790TLVTW	351	L Vrtl Trim
TS790TTC	363	Spanning Top Cap
TS790TTCW	363	Spanning Top Cap
TS790TTVT	351	T Vrtl Trim
TS790TTVTW	351	T Vrtl Trim
TS790TVVT	352	V Vrtl Trim
TS790TVVTW	352	V Vrtl Trim
TS796STC	432	Spanning Top Cap
TS796TTC	363	Spanning Top Cap
TS796TTCW	363	Spanning Top Cap
TS7BPNY24X	490	Bs Pwr Infeed - NYC
TS7BPNY24XN	490	Bs Pwr Infeed - NYC
TS7BPNY24Y	490	Bs Pwr Infeed - NYC
TS7BPNY24YN	490	Bs Pwr Infeed - NYC
TS7BPNY24Z	490	Bs Pwr Infeed - NYC
TS7BPNY24ZN	490	Bs Pwr Infeed - NYC
TS7BPNY30X	490	Bs Pwr Infeed - NYC
TS7BPNY30XN	490	Bs Pwr Infeed - NYC
TS7BPNY30Y	490	Bs Pwr Infeed - NYC
TS7BPNY30YN	490	Bs Pwr Infeed - NYC
TS7BPNY30Z	490	Bs Pwr Infeed - NYC
TS7BPNY30ZN	490	Bs Pwr Infeed - NYC
TS7BPNY36X	490	Bs Pwr Infeed - NYC
TS7BPNY36YN	490	Bs Pwr Infeed - NYC
TS7BPNY36Z	490	Bs Pwr Infeed - NYC
TS7BPNY36ZN	490	Bs Pwr Infeed - NYC
TS7BPNY42X	490	Bs Pwr Infeed - NYC
TS7BPNY42XN	490	Bs Pwr Infeed - NYC
TS7BPNY42Y	490	Bs Pwr Infeed - NYC
TS7BPNY42YN	490	Bs Pwr Infeed - NYC
TS7BPNY42Z	490	Bs Pwr Infeed - NYC
TS7BPNY42ZN	490	Bs Pwr Infeed - NYC
TS7BPNY48X	490	Bs Pwr Infeed - NYC

Style Number	Page	Description
TS7BPNY48XN	490	Bs Pwr Infeed - NYC
TS7BPNY48Y	490	Bs Pwr Infeed - NYC
TS7BPNY48YN	490	Bs Pwr Infeed - NYC
TS7BPNY48Z	490	Bs Pwr Infeed - NYC
TS7BPNY48ZN	490	Bs Pwr Infeed - NYC
TS7BPNY60X	490	Bs Pwr Infeed - NYC
TS7BPNY60XN	490	Bs Pwr Infeed - NYC
TS7BPNY60Y	490	Bs Pwr Infeed - NYC
TS7BPNY60YN	490	Bs Pwr Infeed - NYC
TS7BPNY60Z	490	Bs Pwr Infeed - NYC
TS7BPNY60ZN	490	Bs Pwr Infeed - NYC
TS7BPNY72X	490	Bs Pwr Infeed - NYC
TS7BPNY72XN	490	Bs Pwr Infeed - NYC
TS7BPNY72Y	490	Bs Pwr Infeed - NYC
TS7BPNY72YN	490	Bs Pwr Infeed - NYC
TS7BPNY72Z	490	Bs Pwr Infeed - NYC
TS7BPNY72ZN	490	Bs Pwr Infeed - NYC
TS7CJCA10	359	Jct Cap Cnr Aligner
TS7CMB2	372	T C Mnt Strg – Brkts
TS7CMB2A	372	T C Mnt Strg – Brkts
TS7CMB2A3	372	T C Mnt Strg – Brkts
TS7CPK24	491	Hardwired Pwrkit
TS7CPK30	491	Hardwired Pwrkit
TS7CPK36	491	Hardwired Pwrkit
TS7CPK42	491	Hardwired Pwrkit
TS7CPK48	491	Hardwired Pwrkit
TS7CPK60	491	Hardwired Pwrkit
TS7CPK72	491	Hardwired Pwrkit
TS7DCLSPT	396-398	Ans Boundary Screen
TS7DCLSSD	393-395	Ans Boundary Screen
TS7DCSPN	382	Ans Boundary Screen
TS7DCSPT	383	Ans Boundary Screen
TS7DCSSD	381	Ans Boundary Screen
TS7DF	488	Data Filler
TS7FGJG	367	Frameless Glass
TS7FSLVE	497	Fd-Thru Horiz Cbl Slv
TS7GGC10	356	Gripper Glide Caps
TS7HSLVE	497	Grm for Hor Bar & Jct
TS7JSLVE	498	Grommet for Jct
TS7JTSLVE	496	Jct Tall Sleeve
TS7LSLVE	497	Lay-In Jct Cbl Sleeve
TS7LTA4	359	L to T Trim Aligner
TS7MBSP	447	Mkb Sfcs for St Skins
TS7MTRMNT	596	Ans Monitor Mount
TS7PF	480	Panel and Beam Foot
TS7PK24X	482	4-Cir, 3+1 Wrg, Pwrkit
TS7PK24XN	482	4-Cir, 3+1 Wrg, Pwrkit
TS7PK24Y	482	4-Cir, 2+2 Wrg, Pwrkit
TS7PK24YN	482	4-Cir, 2+2 Wrg, Pwrkit
TS7PK24Z	482	3-Cir, 3SN Wrg, Pwrkt
TS7PK24ZN	482	3-Cir, 3SN Wrg, Pwrkt
TS7PK30X	482	4-Cir, 3+1 Wrg, Pwrkit
TS7PK30XN	482	4-Cir, 3+1 Wrg, Pwrkit
TS7PK30Y	482	4-Cir, 2+2 Wrg, Pwrkt
TS7PK30YN	482	4-Cir, 2+2 Wrg, Pwrkt
TS7PK30Z	482	3-Cir, 3SN Wrg, Pwrkt
TS7PK30ZN	482	3-Cir, 3SN Wrg, Pwrkt
TS7PK36X	482	4-Cir, 3+1 Wrg, Pwrkit
TS7PK36XN	482	4-Cir, 3+1 Wrg, Pwrkit
TS7PK36Y	482	4-Cir, 2+2 Wrg, Pwrkt
TS7PK36YN	482	4-Cir, 2+2 Wrg, Pwrkt

Style Number	Page	Description	Style Number	Page	Description	Style Number	Page	Description
TS7PK36Z	482	3-Cir, 3SN Wrg, Pwrkt	TS7PT48ZN	483	3-Cir, 3SN, P-T Pwrkt	TS7Q8TCLJ	328	L C-O-H Jct
TS7PK36ZN	482	3-Cir, 3SN Wrg, Pwrkt	TS7PT60X	483	4-Cir, 3+1, P-T Pwrkt	TS7Q8TCLJW	328	L C-O-H Jct
TS7PK42X	482	4-Cir, 3+1 Wrg, Pwrkit	TS7PT60XN	483	4-Cir, 3+1, P-T Pwrkt	TS7Q8TCVJ	338	V C-O-H Jct
TS7PK42XN	482	4-Cir, 3+1 Wrg, Pwrkit	TS7PT60Y	483	4-Cir, 2+2, P-T Pwrkt	TS7Q8TCVJW	338	V C-O-H Jct
TS7PK42Y	482	4-Cir, 2+2 Wrg, Pwrkt	TS7PT60YN	483	4-Cir, 2+2, P-T Pwrkt	TS7QQ3TCTJ	333	T C-O-H Jct
TS7PK42YN	482	4-Cir, 2+2 Wrg, Pwrkt	TS7PT60Z	483	3-Cir, 3SN, P-T Pwrkt	TS7QQ3TCTJW	333	T C-O-H Jct
TS7PK42Z	482	3-Cir, 3SN Wrg, Pwrkt	TS7PT60ZN	483	3-Cir, 3SN, P-T Pwrkt	TS7QQ44TCXJ	335	X C-O-H Jct
TS7PK42ZN	482	3-Cir, 3SN Wrg, Pwrkt	TS7PT72X	483	4-Cir, 3+1, P-T Pwrkt	TS7QQ44TCXJW	335	X C-O-H Jct
TS7PK48X	482	4-Cir, 3+1 Wrg, Pwrkit	TS7PT72XN	483	4-Cir, 3+1, P-T Pwrkt	TS7QQ4TCTJ	332	T C-O-H Jct
TS7PK48XN	482	4-Cir, 3+1 Wrg, Pwrkit	TS7PT72Y	483	4-Cir, 2+2, P-T Pwrkt	TS7QQ4TCTJW	332	T C-O-H Jct
TS7PK48Y	482	4-Cir, 2+2 Wrg, Pwrkt	TS7PT72YN	483	4-Cir, 2+2, P-T Pwrkt	TS7QQ55TCXJ	335	X C-O-H Jct
TS7PK48YN	482	4-Cir, 2+2 Wrg, Pwrkt	TS7PT72Z	483	3-Cir, 3SN, P-T Pwrkt	TS7QQ55TCXJW	335	X C-O-H Jct
TS7PK48Z	482	3-Cir, 3SN Wrg, Pwrkt	TS7PT72ZN	483	3-Cir, 3SN, P-T Pwrkt	TS7QQ5TCTJ	332	T C-O-H Jct
TS7PK48ZN	482	3-Cir, 3SN Wrg, Pwrkt	TS7Q33TCYJ	340	Y C-O-H Jct	TS7QQ5TCTJW	332	T C-O-H Jct
TS7PK60X	482	4-Cir, 3+1 Wrg, Pwrkit	TS7Q33TCYJW	340	Y C-O-H Jct	TS7QQ66TCXJ	335	X C-O-H Jct
TS7PK60XN	482	4-Cir, 3+1 Wrg, Pwrkit	TS7Q3QTCTJ	331	T C-O-H Jct	TS7QQ66TCXJW	335	X C-O-H Jct
TS7PK60Y	482	4-Cir, 2+2 Wrg, Pwrkt	TS7Q3QTCTJW	331	T C-O-H Jct	TS7QQ6TCTJ	332	T C-O-H Jct
TS7PK60YN	482	4-Cir, 2+2 Wrg, Pwrkt	TS7Q44TCYJ	341	Y C-O-H Jct	TS7QQ6TCTJW	332	T C-O-H Jct
TS7PK60Z	482	3-Cir, 3SN Wrg, Pwrkt	TS7Q44TCYJW	341	Y C-O-H Jct	TS7QQ88TCXJ	335	X C-O-H Jct
TS7PK60ZN	482	3-Cir, 3SN Wrg, Pwrkt	TS7Q4Q4TCXJ	334	X C-O-H Jct	TS7QQ88TCXJW	335	X C-O-H Jct
TS7PK72X	482	4-Cir, 3+1 Wrg, Pwrkit	TS7Q4Q4TCXJW	334	X C-O-H Jct	TS7QQ8TCTJ	332	T C-O-H Jct
TS7PK72XN	482	4-Cir, 3+1 Wrg, Pwrkit	TS7Q4QTCTJ	330	L C-O-H Jct	TS7QQ8TCTJW	332	T C-O-H Jct
TS7PK72Y	482	4-Cir, 2+2 Wrg, Pwrkt	TS7Q4QTCTJW	330	L C-O-H Jct	TS7QQQ3TCXJ	337	X C-O-H Jct
TS7PK72YN	482	4-Cir, 2+2 Wrg, Pwrkt	TS7Q4TCTJ	327	I C-O-H Jct	TS7QQQ3TCXJW	337	X C-O-H Jct
TS7PK72Z	482	3-Cir, 3SN Wrg, Pwrkt	TS7Q4TCTJW	327	I C-O-H Jct	TS7QQQ4TCXJ	336	X C-O-H Jct
TS7PK72ZN	482	3-Cir, 3SN Wrg, Pwrkt	TS7Q4TCLJ	328	L C-O-H Jct	TS7QQQ4TCXJW	336	X C-O-H Jct
TS7PT18X	483	4-Cir, 3+1, P-T Pwrkt	TS7Q4TCLJW	328	L C-O-H Jct	TS7QQQ5TCXJ	336	X C-O-H Jct
TS7PT18XN	483	4-Cir, 3+1, P-T Pwrkt	TS7Q4TCVJ	338	V C-O-H Jct	TS7QQQ5TCXJW	336	X C-O-H Jct
TS7PT18Y	483	4-Cir, 2+2, P-T Pwrkt	TS7Q4TCVJW	338	V C-O-H Jct	TS7QQQ6TCXJ	336	X C-O-H Jct
TS7PT18YN	483	4-Cir, 2+2, P-T Pwrkt	TS7Q55TCYJ	341	Y C-O-H Jct	TS7QQQ6TCXJW	336	X C-O-H Jct
TS7PT18Z	483	3-Cir, 3SN, P-T Pwrkt	TS7Q55TCYJW	341	Y C-O-H Jct	TS7QQQ8TCXJ	336	X C-O-H Jct
TS7PT18ZN	483	3-Cir, 3SN, P-T Pwrkt	TS7Q5Q5TCXJ	334	X C-O-H Jct	TS7QQQ8TCXJW	336	X C-O-H Jct
TS7PT24X	483	4-Cir, 3+1, P-T Pwrkt	TS7Q5Q5TCXJW	334	X C-O-H Jct	TS7RC	486	Receptacle
TS7PT24XN	483	4-Cir, 3+1, P-T Pwrkt	TS7Q5QTCTJ	330	T C-O-H Jct	TS7RCT	488	Receptacle Trim Rin
TS7PT24Y	483	4-Cir, 2+2, P-T Pwrkt	TS7Q5QTCTJW	330	T C-O-H Jct	TS7SB	343, 411	Jct Stabilizer Bracket
TS7PT24YN	483	4-Cir, 2+2, P-T Pwrkt	TS7Q5TCLJ	327	I C-O-H Jct	TS7SBNJ	343, 411	Jct Stabilizer Bracket
TS7PT24Z	483	3-Cir, 3SN, P-T Pwrkt	TS7Q5TCLJW	327	I C-O-H Jct	TS7SCLSP	388-390	Ans Boundary Screen
TS7PT24ZN	483	3-Cir, 3SN, P-T Pwrkt	TS7Q5TCLJ	328	L C-O-H Jct	TS7SCLSSD	385-387	Ans Boundary Screen
TS7PT30X	483	4-Cir, 3+1, P-T Pwrkt	TS7Q5TCLJW	328	L C-O-H Jct	TS7SCSPN	378	Ans Boundary Screen
TS7PT30XN	483	4-Cir, 3+1, P-T Pwrkt	TS7Q5TCVJ	338	V C-O-H Jct	TS7SCSPT	379	Ans Boundary Screen
TS7PT30Y	483	4-Cir, 2+2, P-T Pwrkt	TS7Q5TCVJW	338	V C-O-H Jct	TS7SCSSD	377	Ans Boundary Screen
TS7PT30YN	483	4-Cir, 2+2, P-T Pwrkt	TS7Q66TCYJ	341	Y C-O-H Jct	TS7STDIV	615	Dividers
TS7PT30Z	483	3-Cir, 3SN, P-T Pwrkt	TS7Q66TCYJW	341	Y C-O-H Jct	TS7STLS1	477	Top Cap Light Seal
TS7PT30ZN	483	3-Cir, 3SN, P-T Pwrkt	TS7Q6Q6TCXJ	334	X C-O-H Jct	TS7STLS10	477	Top Cap Light Seal
TS7PT36X	483	4-Cir, 3+1, P-T Pwrkt	TS7Q6Q6TCXJW	334	X C-O-H Jct	TS7SWS	477	Spnig Win In-Line Sup
TS7PT36XN	483	4-Cir, 3+1, P-T Pwrkt	TS7Q6QTCTJ	330	T C-O-H Jct	TS7TFGRC	367	Frameless Glass
TS7PT36Y	483	4-Cir, 2+2, P-T Pwrkt	TS7Q6QTCTJW	330	T C-O-H Jct	TS7TIEPLATE	553	U Tie Plates
TS7PT36YN	483	4-Cir, 2+2, P-T Pwrkt	TS7Q6TCLJ	327	I C-O-H Jct	TS7TJUP	347	L, T, or X Jct Util Pole
TS7PT36Z	483	3-Cir, 3SN, P-T Pwrkt	TS7Q6TCLJW	327	I C-O-H Jct	TS7TSCFD	474	Tech Skin Cover Filler
TS7PT42X	483	4-Cir, 3+1, P-T Pwrkt	TS7Q6TCLJ	328	L C-O-H Jct	TS7TSCFS	474	Tech Skin Cover Filler
TS7PT42XN	483	4-Cir, 3+1, P-T Pwrkt	TS7Q6TCLJW	328	L C-O-H Jct	TS7TSCOVER	474	Tech Skin Cover
TS7PT42Y	483	4-Cir, 2+2, P-T Pwrkt	TS7Q6TCVJ	338	V C-O-H Jct	TS7UFPLATE	487	Face Plate
TS7PT42YN	483	4-Cir, 2+2, P-T Pwrkt	TS7Q6TCVJW	338	V C-O-H Jct	TS7USB	487	USB Receptacle
TS7PT42Z	483	3-Cir, 3SN, P-T Pwrkt	TS7Q88TCYJ	341	Y C-O-H Jct	TS7WKSPT	553	Reinforcing Chan
TS7PT42ZN	483	3-Cir, 3SN, P-T Pwrkt	TS7Q88TCYJW	341	Y C-O-H Jct	TS7WKSPT39	553	Reinforcing Chan
TS7PT48X	483	4-Cir, 3+1, P-T Pwrkt	TS7Q8Q8TCXJ	334	X C-O-H Jc	TS7WKSPT48	553	Reinforcing Chan
TS7PT48XN	483	4-Cir, 3+1, P-T Pwrkt	TS7Q8Q8TCXJW	334	X C-O-H Jc	TS7WKSPT51	553	Reinforcing Chan
TS7PT48Y	483	4-Cir, 2+2, P-T Pwrkt	TS7Q8QTCTJ	330	T C-O-H Jct	TS7WKSPT54	553	Reinforcing Chan
TS7PT48YN	483	4-Cir, 2+2, P-T Pwrkt	TS7Q8QTCTJW	330	T C-O-H Jct	TS7WKSPT60	553	Reinforcing Chan
TS7PT48Z	483	3-Cir, 3SN, P-T Pwrkt	TS7Q8TCLJ	327	I C-O-H Jct	TS7WKSPT63	553	Reinforcing Chan
			TS7Q8TCLJW	327	I C-O-H Jct	TS7WKSPT66	553	Reinforcing Chan

Style Number Index, continued

Style Number	Page	Description	Style Number	Page	Description	Style Number	Page	Description
TS7WKSPT72	553	Reinforcing Chan	UE2222L	525	U Ext Corner Wksf	UFAL	565	Aligners
TS7WWM	576	U WS Wire Mgr	UE2222R	525	U Ext Corner Wksf	UFC24	556	FO Closed Loop
TSAEGROM	575	Grommet Pkg	UE2226R	525	U Ext Corner Wksf	UFC24LHANS	556	FO Closed Loop
TSAPDSA6636	478	Sliding Pnl Door	UE2228L	525	U Ext Corner Wksf	UFC24NF	557	Infill for FO Legs
TSAPDSA6642	478	Sliding Pnl Door	UE2262L	525	U Ext Corner Wksf	UFC24RHANS	556	FO Closed Loop
TSAPDSA7836	478	Sliding Pnl Door	UE2268L	525	U Ext Corner Wksf	UFC24T	556	FO Closed Loop
TSAPDSA7842	478	Sliding Pnl Door	UE2280R	525	U Ext Corner Wksf	UFC30	556	FO Closed Loop
TSBBOBTRM	361	Conv Kit Big Opn Bse	UE2282R	525	U Ext Corner Wksf	UFC30LHANS	556	FO Open Loop
TSBRF	488	Filler Pkg Pwr	UE2382R	525	U Ext Corner Wksf	UFC30NF	557	Infill for FO Legs
TSTERPDWR	551	Tour Ws Mt Rct Pw/Da	UE2308L	525	U Ext Corner Wksf	UFC30RHANS	556	FO Open Loop
TSTT27M	560	Post Leg	UE2328L	525	U Ext Corner Wksf	UFC30T	556	FO Closed Loop
TSTT27M4	560	Post Leg	UE2368L	525	U Ext Corner Wksf	UFH24LHANS	556	FO Half Loop
UADJ	559	U Adj-Hgt Leg	UE2380R	525	U Ext Corner Wksf	UFH24RHANS	556	FO Half Loop
UADJ4	559	U Adj-Hgt Leg	UE2382R	525	U Ext Corner Wksf	UFH30LHANS	556	FO Half Loop
UADJ4C	559	U Adj-Hgt Leg	UE2386R	525	U Ext Corner Wksf	UFH30RHANS	556	FO Half Loop
UADJ4M	559	U Adj-Hgt Leg	UE3208L	525	U Ext Corner Wksf	UFP	556	FO Post Loop
UADJC	559	U Adj-Hgt Leg	UE3228L	525	U Ext Corner Wksf	UFPM	562	Uni Prv/ Mod Screen
UADJCOL	560	Adjustable Column	UE3268L	525	U Ext Corner Wksf	UFPS	565	Uni Prv Screen
UB223636	529	U 120° WS CD	UE3280R	525	U Ext Corner Wksf	UFQ24	556	FO Open Loop
UB224242	529	U 120° WS CD	UE3282R	525	U Ext Corner Wksf	UFQ24LHANS	556	FO Open Loop
UB224848	529	U 120° WS CD	UE3286R	525	U Ext Corner Wksf	UFQ24NF	557	Infill for FO Legs
UB333636	529	U 120° WS CD	UE3308L	525	U Ext Corner Wksf	UFQ24RHANS	556	FO Open Loop
UB334242	529	U 120° WS CD	UE3328L	525	U Ext Corner Wksf	UFQ24T	556	FO Open Loop
UB334848	529	U 120° WS CD	UE3368L	525	U Ext Corner Wksf	UFQ30	556	FO Open Loop
UC114242	521	U Cor WS, Frnt—CD	UE3380R	525	U Ext Corner Wksf	UFQ30LHANS	556	FO Open Loop
UC124242	521	U Cor WS, Frnt—CD	UE3382R	525	U Ext Corner Wksf	UFQ30NF	557	Infill for FO Legs
UC214242	521	U Cor WS, Frnt—CD	UE3386R	525	U Ext Corner Wksf	UFQ30RHANS	556	FO Open Loop
UC223636	521	U Cor WS, Frnt—CD	UEC2202L	527	U Ext Corner Wksf	UFQ30T	556	FO Open Loop
UC224242	521	U Cor WS, Frnt—CD	UEC2208L	527	U Ext Corner Wksf	UFS1610H	556	FO Inter Support
UC224848	521	U Cor WS, Frnt—CD	UEC2220R	528	U Ext Corner Wksf	UFS1615H	556	FO Inter Support
UC226060	521	U Cor WS, Frnt—CD	UEC2222L	527	U Ext Corner Wksf	UFS24ANS	555	Off-Md Wsf-to-Pnl Con
UC334242	521	U Cor WS, Frnt—CD	UEC2222R	528	U Ext Corner Wksf	UFS30ANS	555	Off-Md Wsf-to-Pnl Con
UC334848	521	U Cor WS, Frnt—CD	UEC2226R	528	U Ext Corner Wksf	UFS36ANS	555	Off-Md Wsf-to-Pnl Con
UCANT	552	U On-Mod CANT	UEC2228L	527	U Ext Corner Wksf	UFS42ANS	555	Off-Md Wsf-to-Pnl Con
UCC113636	523	U Cor WS, Frnt—CD	UEC2262L	527	U Ext Corner Wksf	UFS48ANS	555	Off-Md Wsf-to-Pnl Con
UCC114242	523	U Cor WS, Frnt—CD	UEC2268L	527	U Ext Corner Wksf	UFS60ANS	555	Off-Md Wsf-to-Pnl Con
UCC114848	523	U Cor WS, Frnt—CD	UEC2280R	528	U Ext Corner Wksf	UFS72ANS	555	Off-Md Wsf-to-Pnl Con
UCC124242	523	U Cor WS, Frnt—CD	UEC2282R	528	U Ext Corner Wksf	UFSLOWLHANS	649	Conn
UCC214242	523	U Cor WS, Frnt—CD	UEC2286R	528	U Ext Corner Wksf	UFSLOWRHANS	649	Conn
UCC223636	523	U Cor WS, Frnt—CD	UEC2308L	527	U Ext Corner Wksf	UFSMEDLHANS	649	Conn
UCC224242	523	U Cor WS, Frnt—CD	UEC2328L	527	U Ext Corner Wksf	UFSMEDRHANS	649	Conn
UCC224848	523	U Cor WS, Frnt—CD	UEC2368L	527	U Ext Corner Wksf	UFSTALLLHANS	649	Conn
UCC226060	523	U Cor WS, Frnt—CD	UEC2380R	528	U Ext Corner Wksf	UFSTALLRHANS	649	Conn
UCC334242	523	U Cor WS, Frnt—CD	UEC2382R	528	U Ext Corner Wksf	UFSTB	625	Lw Stg-to-Bm Thr Brkt
UCC334848	523	U Cor WS, Frnt—CD	UEC2386R	528	U Ext Corner Wksf	UFSTOWER24	648	Connector
UCF223636	519	U Cnr, FT-Frt WS—CD	UEC3208L	527	U Ext Corner Wksf	UFSTOWER30	648	Connector
UCF224242	519	U Cnr, FT-Frt WS—CD	UEC3228L	527	U Ext Corner Wksf	UHDPL	559	U Dbl Post Leg
UCF224848	519	U Cnr, FT-Frt WS—CD	UEC3268L	527	U Ext Corner Wksf	UHPL	558	U Post Leg
UCF334242	519	U Cnr, FT-Frt WS—CD	UEC3280R	528	U Ext Corner Wksf	UJBC2430L	539	U Bubl Jetty WS CD
UCF334848	519	U Cnr, FT-Frt WS—CD	UEC3282R	528	U Ext Corner Wksf	UJBC2430R	539	U Bubl Jetty WS CD
UCL	559	U Dbl Post C-Leg	UEC3286R	528	U Ext Corner Wksf	UJBC2436L	539	U Bubl Jetty WS CD
UCOL	560	Column	UEC3308L	527	U Ext Corner Wksf	UJBC2436R	539	U Bubl Jetty WS CD
UCSP	554	U On-Md Cen Sprt Pnl	UEC3328L	527	U Ext Corner Wksf	UJBC2442L	539	U Bubl Jetty WS CD
UCSPS	554	U On-Md Cen Sprt Pnl	UEC3368L	527	U Ext Corner Wksf	UJBC2442R	539	U Bubl Jetty WS CD
UDC224242	520	U Dual Corner Wksf	UEC3380R	528	U Ext Corner Wksf	UJBC2448L	539	U Bubl Jetty WS CD
UDC224848	520	U Dual Corner Wksf	UEC3382R	528	U Ext Corner Wksf	UJBC2448R	539	U Bubl Jetty WS CD
UDC334848	520	U Dual Corner Wksf	UEC3386R	528	U Ext Corner Wksf	UJC2382R	537	U Jetty WS, Fr CD
UDPL	559	U Dbl Post Leg	UEP24	554	U On-Module End Pnl	UJC2386R	537	U Jetty WS, Fr CD
UE2202L	525	U Ext Corner Wksf	UEP24S	554	U On-Module End Pnl	UJC2388R	537	U Jetty WS, Fr CD
UE2208L	525	U Ext Corner Wksf	UEP30	554	U On-Module End Pnl	UJC3228L	537	U Jetty WS, Fr CD
UE2220R	525	U Ext Corner Wksf	UEP30S	554	U On-Module End Pnl	UJC3268L	537	U Jetty WS, Fr CD

Style Number	Page	Description	Style Number	Page	Description	Style Number	Page	Description
UJC3288L	537	U Jetty WS, Fr CD	US3024	502	U Str WS CD	UT3260L	515	U Trans WS CD
UJC3328L	537	U Jetty WS, Fr CD	US3030	502	U Str WS CD	UTR1630A	545	U Transaction WS
UJC3368L	537	U Jetty WS, Fr CD	US3036	502	U Str WS CD	UTR1630SA	545	U Transaction WS
UJC3382R	537	U Jetty WS, Fr CD	US3042	502	U Str WS CD	UTR1630TA	545	U Transaction WS
UJC3386R	537	U Jetty WS, Fr CD	US3048	502	U Str WS CD	UTR1636A	545	U Transaction WS
UJC3388L	537	U Jetty WS, Fr CD	US3054	502	U Str WS CD	UTR1636SA	545	U Transaction WS
UJC3388R	537	U Jetty WS, Fr CD	US3060	502	U Str WS CD	UTR1636TA	545	U Transaction WS
ULC2727	543	U Lk WS, CRV-FR CD	US3066	502	U Str WS CD	UTR1642A	545	U Transaction WS
ULFF24F	661	Undwksf Lat File Filler	US3072	502	U Str WS CD	UTR1642SA	545	U Transaction WS
ULFF24P	661	Undwksf Lat File Filler	US3660	502	U Str WS CD	UTR1642TA	545	U Transaction WS
ULFF30F	661	Undwksf Lat File Filler	US3666	502	U Str WS CD	UTR1648A	545	U Transaction WS
ULFF30P	661	Undwksf Lat File Filler	US3672	502	U Str WS CD	UTR1648SA	545	U Transaction WS
UNPL	558	U Post Leg	USE2448LH	513	120° Straight Wksf	UTR1648TA	545	U Transaction WS
UNPL4	558	U Post Leg	USE2448RH	513	120° Straight Wksf	UTR1660A	545	U Transaction WS
UNPL4C	558	U Post Leg	USE2460LH	513	120° Straight Wksf	UTR1660SA	545	U Transaction WS
UNPL4M	558	U Post Leg	USE2460RH	513	120° Straight Wksf	UTR1660TA	545	U Transaction WS
UNPLC	558	U Post Leg	USE2472LH	513	120° Straight Wksf	UTT1248	516	U Taprd WS CD
UPA2448	533	U Angled Pnsl WS CD	USE2472RH	513	120° Straight Wksf	UTT1260	516	U Taprd WS CD
UPA2460	533	U Angled Pnsl WS CD	USE3048LH	513	120° Straight Wksf	UTT1272	516	U Taprd WS CD
UPA3048	533	U Angled Pnsl WS CD	USE3048RH	513	120° Straight Wksf	UTT2148	516	U Taprd WS CD
UPA3060	533	U Angled Pnsl WS CD	USE3060LH	513	120° Straight Wksf	UTT2160	516	U Taprd WS CD
UPAC2748	534	U Ang Penin WS, CD	USE3060RH	513	120° Straight Wksf	UTT2172	516	U Taprd WS CD
UPBC2448	532	Bullet Pnsl WS CD/FD	USE3072LH	513	120° Straight Wksf	UTT2348	516	U Taprd WS CD
UPBC2460	532	Bullet Pnsl WS CD/FD	USE3072RH	513	120° Straight Wksf	UTT2360	516	U Taprd WS CD
UPBC2466	532	Bullet Pnsl WS CD/FD	USPC47	531	U Spnr WS CD	UTT2372	516	U Taprd WS CD
UPBC2472	532	Bullet Pnsl WS CD/FD	USPC51	531	U Spnr WS CD/FD	UTT3248	516	U Taprd WS CD
UPBC3048	532	Bullet Pnsl WS CD/FD	USPC59	531	U Spnr WS CD	UTT3260	516	U Taprd WS CD
UPBC3060	532	U Bullet Penn WS, CD	USPC63	531	U Spnr WS CD/FD	UTT3272	516	U Taprd WS CD
UPBC3066	532	U Bullet Penn WS, CD	USSBR	552	U Side Supp Brkt	UTTF1260	517	U Taper-Flat WS CD
UPBC3072	532	U Bullet Penn WS, CD	UST1260	518	U Sgl-Tprd WS CD	UTTF1272	517	U Taper-Flat WS CD
UPL	558	U Post Leg	UST1272	518	U Sgl-Tprd WS CD	UTTF1360	517	U Taper-Flat WS CD
UPL4	558	U Post Leg	UST2160	518	U Sgl-Tprd WS CD	UTTF1372	517	U Taper-Flat WS CD
UPL4C	558	U Post Leg	UST2172	518	U Sgl-Tprd WS CD	UTTF2160	517	U Taper-Flat WS CD
UPL4M	558	U Post Leg	UST2360	518	U Sgl-Tprd WS CD	UTTF2172	517	U Taper-Flat WS CD
UPLC	558	U Post Leg	UST2372	518	U Sgl-Tprd WS CD	UTTF2360	517	U Taper-Flat WS CD
US1824	501	U Str WS CD	UST3260	518	U Sgl-Tprd WS CD	UTTF2372	517	U Taper-Flat WS CD
US1830	501	U Str WS CD	UST3272	518	U Sgl-Tprd WS CD	UTTF3160	517	U Taper-Flat WS CD
US1836	501	U Str WS CD	USWS	507	U Str WS PM	UTTF3172	517	U Taper-Flat WS CD
US1842	501	U Str WS CD	USWSK	507	U Str WS PM	UTTF3260	517	U Taper-Flat WS CD
US1848	501	U Str WS CD	USWSS	511	U Str WS PM	UTTF3272	517	U Taper-Flat WS CD
US1854	501	U Str WS CD	USWSSW	507	Strgt Wkf w/Sft Eg PM	UTTRC	547	Cord and Plug
US1860	501	U Str WS CD	USWSSWS	511	Strgt Wkf w/Sft Eg PM	UTTRCN	547	Cord and Plug
US1866	501	U Str WS CD	UT1236R	515	U Trans WS CD	UTTRHW	547	Hardwire Power
US1872	501	U Str WS CD	UT1242R	515	U Trans WS CD	UTTRHWN	547	Hardwire Power
US1878	501	U Str WS CD	UT1248R	515	U Trans WS CD	UTTRM	547	Modular Power
US1884	501	U Str WS CD	UT1254R	515	U Trans WS CD	UTTRMN	547	Modular Power
US1890	501	U Str WS CD	UT1260R	515	U Trans WS CD	UVC2424L	541	U Visitor Wksf
US1896	501	U Str WS CD	UT1260R	515	U Trans WS CD	UVC2424R	542	U Visitor Wksf
US2424	502	U Str WS CD	UT1242L	515	U Trans WS CD	UVC2430L	541	U Visitor Wksf
US2430	502	U Str WS CD	UT1248L	515	U Trans WS CD	UVC2430R	542	U Visitor Wksf
US2436	502	U Str WS CD	UT1254L	515	U Trans WS CD	UVC2436L	541	U Visitor Wksf
US2442	502	U Str WS CD	UT1260L	515	U Trans WS CD	UVC2436R	542	U Visitor Wksf
US2448	502	U Str WS CD	UT2336R	515	U Trans WS CD	UVC2442L	541	U Visitor Wksf
US2454	502	U Str WS CD	UT2342R	515	U Trans WS CD	UVC2442R	542	U Visitor Wksf
US2460	502	U Str WS CD	UT2348R	515	U Trans WS CD	UVC2448L	541	U Visitor Wksf
US2466	502	U Str WS CD	UT2354R	515	U Trans WS CD	UVC2448R	542	U Visitor Wksf
US2472	502	U Str WS CD	UT2360R	515	U Trans WS CD	UVC3030L	541	U Visitor Wksf
US2478	502	U Str WS CD	UT3236L	515	U Trans WS CD	UVC3030R	542	U Visitor Wksf
US2484	502	U Str WS CD	UT3242L	515	U Trans WS CD	UVC3036L	542	U Visitor Wksf
US2490	502	U Str WS CD	UT3248L	515	U Trans WS CD	UVC3036R	542	U Visitor Wksf
US2496	502	U Str WS CD	UT3254L	515	U Trans WS CD	UVC3042L	542	U Visitor Wksf

Style Number Index, continued

Style Number	Page	Description
UVC3042R	542	U Visitor Wksf
UVC3048L	542	U Visitor Wksf
UVC3048R	542	U Visitor Wksf
WCC113636	523	U Corner Wksf
WCC114242	523	U Corner Wksf
WCC114848	523	U Corner Wksf
WCC124242	523	U Corner Wksf
WCC214242	523	U Corner Wksf
WCC223636	523	U Corner Wksf
WCC224242	523	U Corner Wksf
WCC224848	523	U Corner Wksf
WCC334242	523	U Corner Wksf
WCC334848	523	U Corner Wksf
WCF223636	519	U CNR, Flat-Fr WS FD
WCF224242	519	U CNR, Flat-Fr WS FD
WCF224848	519	U CNR, Flat-Fr WS FD
WCF334242	519	U CNR, Flat-Fr WS FD
WCF334848	519	U CNR, Flat-Fr WS FD
WDC224242	520	U Dual Corner Wksf
WDC224848	520	U Dual Corner Wksf
WDC334848	520	U Dual Corner Wksf
WEC224260	528	U Ext Corner Wksf
WEC224272	528	U Ext Corner Wksf
WEC224860	528	U Ext Corner Wksf
WEC224872	528	U Ext Corner Wksf
WEC226042	527	U Ext Corner Wksf
WEC226048	527	U Ext Corner Wksf
WEC227242	527	U Ext Corner Wksf
WEC227248	527	U Ext Corner Wksf
WEC234260	528	U Ext Corner Wksf
WEC234272	528	U Ext Corner Wksf
WEC234860	528	U Ext Corner Wksf
WEC234872	528	U Ext Corner Wksf
WEC236042	527	U Ext Corner Wksf
WEC236048	527	U Ext Corner Wksf
WEC237242	527	U Ext Corner Wksf
WEC237248	527	U Ext Corner Wksf
WEC324260	528	U Ext Corner Wksf
WEC324272	528	U Ext Corner Wksf
WEC324860	528	U Ext Corner Wksf
WEC324872	528	U Ext Corner Wksf
WEC326042	527	U Ext Corner Wksf
WEC326048	527	U Ext Corner Wksf
WEC327242	527	U Ext Corner Wksf
WEC327248	527	U Ext Corner Wksf
WEC334260	528	U Ext Corner Wksf
WEC334272	528	U Ext Corner Wksf
WEC334860	528	U Ext Corner Wksf
WEC334872	528	U Ext Corner Wksf
WEC336042	527	U Ext Corner Wksf
WEC336048	527	U Ext Corner Wksf
WEC337242	527	U Ext Corner Wksf
WEC337248	527	U Ext Corner Wksf
WJ234866R	537	Jetty Worksurface FD
WJ234872R	537	Jetty Worksurface FD
WJ234878R	537	Jetty Worksurface FD
WJ326648L	537	Jetty Worksurface FD
WJ327248L	537	Jetty Worksurface FD
WJ327848L	537	Jetty Worksurface FD
WJ334866R	537	Jetty Worksurface FD
WJ334872R	537	Jetty Worksurface FD

Style Number	Page	Description
WJ334878R	537	Jetty Worksurface FD
WJ336648L	537	Jetty Worksurface FD
WJ337248L	537	Jetty Worksurface FD
WJ337848L	537	Jetty Worksurface FD
WLC2727	543	U Linking WS FD
WLC3333	543	U Linking WS FD
WPA2448	533	U Angled Pnsl WS FD
WPA2460	533	U Angled Pnsl WS FD
WPA3048	533	U Angled Pnsl WS FD
WPA3060	533	U Angled Pnsl WS FD
WS1824	501	U Str WS FD
WS1830	501	U Str WS FD
WS1836	501	U Str WS FD
WS1842	501	U Str WS FD
WS1848	501	U Str WS FD
WS1854	501	U Str WS FD
WS1860	501	U Str WS FD
WS1866	501	U Str WS FD
WS1872	501	U Str WS FD
WS1878	501	U Str WS FD
WS1884	501	U Str WS FD
WS1890	501	U Str WS FD
WS1896	501	U Str WS FD
WS2424	502	U Str WS FD
WS2430	502	U Str WS FD
WS2436	502	U Str WS FD
WS2442	502	U Str WS FD
WS2448	502	U Str WS FD
WS2454	502	U Str WS FD
WS2460	502	U Str WS FD
WS2466	502	U Str WS FD
WS2472	502	U Str WS FD
WS2478	502	U Str WS FD
WS2484	502	U Str WS FD
WS2490	502	U Str WS FD
WS2496	502	U Str WS FD
WS3024	502	U Str WS FD
WS3030	502	U Str WS FD
WS3036	502	U Str WS FD
WS3042	502	U Str WS FD
WS3048	502	U Str WS FD
WS3054	502	U Str WS FD
WS3060	502	U Str WS FD
WS3066	502	U Str WS FD
WS3072	502	U Str WS FD
WSPC4824	531	U Spnr WS FD
WSPC5126	531	U Spnr WS CD/FD
WSPC6030	531	U Spnr WS FD
WSPC6332	531	U Spnr WS CD/FD
WST1260	518	U Sgl-Taprd WS FD
WST1272	518	U Sgl-Taprd WS FD
WST2160	518	U Sgl-Taprd WS FD
WST2172	518	U Sgl-Taprd WS FD
WST2360	518	U Sgl-Taprd WS FD
WST2372	518	U Sgl-Taprd WS FD
WST3260	518	U Sgl-Taprd WS FD
WST3272	518	U Sgl-Taprd WS FD
WT2336	515	U Trans WS FD
WT2342	515	U Trans WS—FD0
WT2348	515	U Trans WS—FD
WT2354	515	U Trans WS—FD

Style Number	Page	Description
WT2360	515	U Trans WS—FD
WT2326	515	U Trans WS—FD
WT3242	515	U Trans WS—FD
WT3248	515	U Trans WS—FD
WT3254	515	U Trans WS—FD
WT3260	515	U Trans WS—FD
WTT1248	516	U Sgl-Taprd WS FD
WTT1260	516	U Sgl-Taprd WS FD
WTT1272	516	U Sgl-Taprd WS FD
WTT2148	516	U Sgl-Taprd WS FD
WTT2160	516	U Sgl-Taprd WS FD
WTT2172	516	U Sgl-Taprd WS FD
WTT2348	516	U Sgl-Taprd WS FD
WTT2360	516	U Sgl-Taprd WS FD
WTT2372	516	U Sgl-Taprd WS FD
WTT3248	516	U Sgl-Taprd WS FD
WTT3260	516	U Sgl-Taprd WS FD
WTT3272	516	U Sgl-Taprd WS FD
WTTF1260	517	U Taper-Flat WS—FD
WTTF1272	517	U Taper-Flat WS—FD
WTTF1360	517	U Taper-Flat WS—FD
WTTF1372	517	U Taper-Flat WS—FD
WTTF2160	517	U Taper-Flat WS—FD
WTTF2172	517	U Taper-Flat WS—FD
WTTF2360	517	U Taper-Flat WS—FD
WTTF2372	517	U Taper-Flat WS—FD
WTTF3160	517	U Taper-Flat WS—FD
WTTF3172	517	U Taper-Flat WS—FD
WTTF3260	517	U Taper-Flat WS—FD
WTTF3272	517	U Taper-Flat WS—FD
WVC2424L	541	U Visitor Wksf
WVC2424R	542	U Visitor Wksf
WVC2430L	541	U Visitor Wksf
WVC2430R	542	U Visitor Wksf
WVC3030L	541	U Visitor Wksf
WVC3030R	542	U Visitor Wksf
ZB1R1IGH	484	20-Amp Duplex Rcpt
ZB1R1SGH	484	20-Amp Duplex Rcpt
ZB1R2IGH	484	20-Amp Duplex Rcpt
ZB1R2SGH	484	20-Amp Duplex Rcpt
ZB1R3IGH	484	20-Amp Duplex Rcpt
ZB1R3SGH	484	20-Amp Duplex Rcpt
ZB1R4IGH	484	20-Amp Duplex Rcpt
ZB1R4SGH	484	20-Amp Duplex Rcpt
ZB2R1IGH	484	20-Amp Duplex Rcpt
ZB2R1SGH	484	20-Amp Duplex Rcpt
ZB2R2IGH	484	20-Amp Duplex Rcpt
ZB2R2SGH	484	20-Amp Duplex Rcpt
ZB2R3IGH	484	20-Amp Duplex Rcpt
ZB2R3SGH	484	20-Amp Duplex Rcpt
ZB2R4IGH	484	20-Amp Duplex Rcpt
ZB2R4SGH	484	20-Amp Duplex Rcpt
ZB3R1IGH	484	20-Amp Duplex Rcpt
ZB3R1SGH	484	20-Amp Duplex Rcpt
ZB3R2IGH	484	20-Amp Duplex Rcpt
ZB3R2SGH	484	20-Amp Duplex Rcpt
ZB3R3IGH	484	20-Amp Duplex Rcpt
ZB3R3SGH	484	20-Amp Duplex Rcpt

Trademark List

™/® The following is a non-exhaustive list of trademarks and registered trademarks for products of Steelcase Inc. or one of its related corporate entities: Agree, Airtouch, Alight, Amia, Answer, Aspekt, Avenir, Await, B-Free, Ballet, Bassline, Bindu, Bivi, Bix, Bottomline, Brody, Buoy, Cachet, Campfire, Capa, CF Series, CG_1, Chord, Circa, Clipper, Cobi, Collaboration, Convene, Coupe, Cura, Currency, dash, Divisio, Duo, E-Table 2, Edge Series, Elbrook, Elective Elements, Embold, Empath, Everwall, Exponents, Folio, FrameOne, Gesture, Groupwork, Host, Hosu, i2i, Jenny, Kart, Kathryn, Kick, Lagunitas, Leap, Leela, LessThanFive, LiveBack, LiveSeat, Mackinac, Marien152, Max-Stacker, media:scape, Migration, Millbrae, Mineral, Mitra, Montage, Montara650, MoreThanFive, Move, Node, Ocular, Ology, Opus, Paperflo, Passerelle, Player, Pocket, Potrero415, QiVi, Radia, Regard, Relay, Reply, Ripple, Roam, Sarto, Scoop, Sebastopol, Senti Series, Senza, Shortcut, Sidewalk, Siento, Sieste, SILQ, Soffio, Sorrel, SOTO, Steelcase Eclipse, Steelcase Flex, Steelcase Karman, Steelcase Relay, Steelcase Rise, Steelcase Series, Surround, SW_1, Switch, Sync, Tava, Tenor, Think, Thoughtful, Thread, Together, Train, Trees, Turnstone, Umami, Underscore, V.I.A., Verb, Verge, Verlay, Victor2, Visalia, WorkValet, and X-tenz.

™/® The following are trademarks or registered trademarks of AMQ Solutions, LLC: 3F, Activ, Amobi, Bixby, Bodi, Cluvo, Concur, Embank, FL-X, Iline, Jaku, Kinex, Personality Plus, Revi, S-Series, Siya, Tektis, Tizu, Uptake, and Zilo.

™/® The following are trademarks or registered trademarks of Orangebox Ltd., Cardiff, UK: Air3, Aspect, Avi, Away from the Desk, Border, Campers & Dens, Coppice, Cubb, Kirm, On the QT, Ramsey, Skomer, Sully, Track-B, and Vale.

™/® The following are trademarks or registered trademarks of Viccarbe Habitat, S.L.: Aleta, Cambio, Designed in The Sun, Foro, Funda, Holy Day, Kelly, Last Minute, Noha, Savina, Sistema, Sistema, Viable, and Wrapp.

® The following are registered brands of Steelcase Inc. and its family of companies: Steelcase, AMQ, Coalesse, Designtex, Halcon, Orangebox, Smith System, and Viccarbe.

® The following registered trademarks are under license from AWI Licensing Company, Dover, DE: SoundScapes, DuraBrite, BioBlock, and Armstrong.

® The following registered trademarks are under license from Byrne Electrical, Rockford, MI: Interport, Mini-Port, Axil Z, and Ellora.

® The following is a registered trademark of DuPont, Wilmington, DE: Corian.

® The following is a registered trademark of Genlyte Thomas Company, Louisville, KY: Lightolier.

® The following is a registered trademark of Hilti Corporation, FL-9494 Schaan, Principality of Liechtenstein: Hilti.

® The following is a registered trademark of Leviton Manufacturing Company, Little Neck, NY: Decora.

® The following is a registered trademark of Mechanical Plastics Corp, Elmsford, NY: Toggler.

® The following is a registered trademark of Microsoft Corporation, Redmond, WA: Microsoft.

® The following are registered trademarks of Orangebox Ltd., Cardiff, UK: Orangebox.

® The following is a registered trademark of Panduit Corporation, Lockport, IL: Panduit.

® The following is a registered trademark of Trav (Press), Cuneo, Italy: Assisa.

® The following is a registered trademark of Virtual Ink, Boston, MA: mimioActive.

® The following registered trademarks are under license from Wilkhahn Furniture Products: Avera, Senzo, Versal, and Wilkhahn FS.

® The following are registered trademarks of Polyvision Corp: Flow, Motif, Polyvision, Sans, and Serif.

® The following is a registered trademark of Wilsonart International, Temple, TX: Chemsurf.

® The following is a registered trademark of Wiremold, West Hartford, CT: Wiremold.

® The following is a registered trademark of EMU Group S.P.A., Perugia, Italy: EMU.

® The following is a registered trademark of Security People, Inc.: Digilock.

® The following are registered trademarks of Natural Capital Partners Europe Limited: CarbonNeutral and the CarbonNeutral Certified logo.

™ The following is a trademark of Microsoft Corporation, Redmond, WA: Windows.

™ The following is a trademark of Rodman Industries, Inc., Oconomowoc, WI: ResinCore1.

™ The following is a trademark of Ultrafabrics, LLC, Elmsford, NY: Ultraleather.

™ The following trademarks are under license from Wilkhahn Furniture products: Cana, Linus, Logon, Picto, Range, Stitz, Thema, Timetable, and Tubis.

™ The following trademarks are under license from Walter Knoll: Andoo, Bob, Lazlo, Lox, Ribbon, and Together.

™ The following trademarks are under license from PP Mobler: Bar and Flag Halyard.

™ The following trademarks are under license from Carl Hansen: Elbow, Paddle, Shell, Wing, and Wishbone.

™ The following trademarks are under license from Cambridge Sound Management, LLC Cambridge, MA: QtPro Soundmasking, Qt Quiet Technology, and Sonet Qt.

™ The following is a trademark of Electri-Cable Assemblies, Shelton, CT: Interact.

™ The following is a trademark of Clestra Hauserman: IRYS.

™ The following is a trademark of Wiesner-Hager Möbel GmbH: Nooi.

™ The following are trademarks of Polyvision: Accord, a3, e3, Boundri, and Nota.

™ The following is a trademark of Bostock Company, Inc: SnapCab.

™ The following is a trademark of Williams-Sonoma, Inc: West Elm.

™ The following is a trademark of Elena Marquina Testor: nanimarquina.

™ The following is a trademark of Forbo International SA: Forbo.

Trademarks used herein are the property of Steelcase Inc. or their respective owners.