

GENERAL REMINDERS

1. Professors will be responsible to self-jury their students and only submit the best two projects (2) per independently taught class/studio for judging in this competition
2. All final submittals are to be sent to: design4next@gmail.com All submittals are due by December 11th.
3. Submittals must be in PDF format and be **no greater than 20MB in file size** (no min/max on number of pages)
4. As a reminder, all student participants must be currently registered as juniors or seniors in their design program, 5TH year students enrolled into a 5 year Masters program, or in a master's program where there is no bachelor's degree offered or a master's program where the students have no bachelor's degree in design or other previous design experience.
5. Students must submit an entry as an individual, not as part of a team.
6. **All questions must be submitted by September 27th** and all questions must be submitted to: design4next@steelcase.com
7. Each student participating **MUST individually register no later than September 27th** to be considered eligible. Students can register by going to this link: [Student Registration Link](#)

(NEW) Q+A QUESTIONS + ANSWERS – Questions submitted September 21-27, 2024

Q. If a student wants to open the 7th floor between columns, is there a beam connecting the columns?

A: There are no beams. The ceiling is a flat concrete surface. Please see this image below. This image was inadvertently left off of the Q+A document published this morning and I will be circulating it to everyone.



UPDATE: Hello everyone, I just realized there were two additional photos of the “NEXT space” that were inadvertently left off of the Q+A document published this morning. These will be updated and added to the next document we publish; however, I wanted to get these two you ASAP before since it won’t be published until next Monday. These show a bit more of the HVAC Cassette System and HVAC running throughout the space below the deck (ceiling level) as well as window detailing and (somewhat) external views.

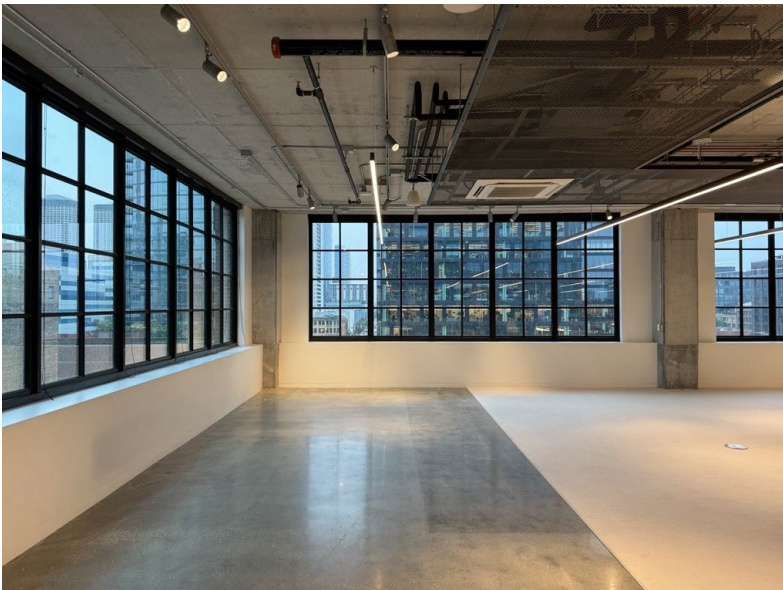

Q: Can the shape/style of the skylight be changed from square to circular?

A: The skylight may not be altered.

Q: Can additional skylights be added?

A: No additional skylights may be added.

Q: On inclusive design we were thinking about adding / converting a few unisex single stall toilet rooms. However, knowing the building core and restrooms should not be modified, I wonder if you have any recommendations, or we should just stay clear of these types of modifications?

A: You do have good suggestions here regarding inclusive design; however, since the bathrooms are out of scope, I wouldn't modify them since that area will not be evaluated by the judges. The time should be spent focusing on the spaces that are in scope.

Q: Program page 22 notes that the client services director works closely with the director of digital marketing, however on page 23 in the private offices detail, it notes that the director of client services and the creative director work together constantly and should be in close proximity. Should we read this as these three need to be in close proximity with each other? Or is there more of a relationship between the director of client services and creative director than there is between the director of client services and the director of digital marketing?

A: Sorry about the confusion created here. We should have provided more context to make it explicit. The two that work the closest together (constantly) are the Client Services Director and Creative Director and they are both the two partners in this branch location. Their adjacency is important. The Creative Director and the Digital Marketing director do work closely together as do each of their departments so departmental adjacency is important between these two groups.

Q: Can we delete any ceilings found in the provided Revit model?

A: If there are any drop ceilings that were not removed in the file (ie: ceilings that are not part of the base building/concrete floors) then they may be removed.

Q: Should we assume that a hole in the floor slab that crosses column lines would have to maintain a beam passing through the opening to maintain the integrity of the base building structural system? My question is regarding making new holes in the 7th floor for the monumental stair or an overlooking balcony. Should we assume there are structural elements along column lines inside the 9" thick floor slab that must be preserved for structural integrity, or are we free to create openings that cross column lines without keeping a portion of the slab intact along the column lines to function as a "beam" between columns. Since we have a column grid, are we to assume there is integral structure in the floor slabs along column lines that cannot be removed when creating openings?

A: Yes, students should assume there is structural elements within the slab of the floor along the column lines that must be preserved for structural integrity. Therefore, any holes in the 7th floor slab for the monumental staircase and/or creating a balcony effect, they must be within the column lines and not cross them.

Q: There are some electrical outlets shown in the Revit model. Are we limited to accessing power at these locations, or can we ignore these and assume power is available at all walls and columns? Can we assume a floor electrical box can be located as needed, or are we limited to power from walls and columns?

A: For this competition, students may assume they can provide power from ANY wall, column, or within the floor. We want to provide as much flexibility here as possible.

Q: Are the two workstations and one office provided for visitors strictly for the use of employees visiting from other offices (NYC, LA, London, Hong Kong) or would these be available for the use of clients as well?

A: The intended purpose of these spaces is for use for visiting NEXT employees; however, if you would like to make them multi-purpose for clients to use if they are not occupied (and if this is part of the student's design intent), it would be permitted.

Q: Are we able to break up the cafe area into multiple cafes or just one large area?

A: This question was answered on page 6 of the Q+A document that was published on Monday, September 23.

Q: Do the groups of Private offices and workstations for each department have to be on the same floor as the rest of the groups?

A: This is a decision the student should make based on their design intent. They should determine which decision best serves NEXT and achieving their goals/objectives.

Q: Does there have to be an equipment room, HVAC, or IT tech room allocated on the 6th and 7th floor?

A: Assumptions can be made that these are accommodated for as this is not part of the design competition evaluation.

Q: What does it mean when it says that there has to be a client celebration area in the reception area or at least in sight view? What does the celebration area need to consist of?

A: As mentioned in the program document, "This is a place to celebrate client campaigns through different mediums (digital, physical, artwork, logos, videos, packaging, placards, etc.)" In essence, this is a way to feature and celebrate the clients and campaigns NEXT has implemented for their existing clients and could be seen as new/potential clients enter NEXT. The students have creative freedom on how they would like to express this.

Q: Can we add another door into the woman's bathroom?

A: The bathrooms are considered out of scope and shouldn't be altered.

Q: Are we allowed to design additional spaces outside of the areas that have been requested in the package? For example, the reading area?

A: As long as the required spaces and desired SF for each are achieved (including the wildcard space), this may be permitted if it meets the student's design intent.

Q: Areas that cannot be changed such as the elevator and the walls of the elevator, can we freely choose the materials?

A: Students may choose any materials for the exterior of these spaces.

Q: Regarding the water tank, do I need to show it in the drawing?

A: Not required to do so

Q: Does the organizer have any requirements for HVAC?

A: We provided photos of the existing HVAC in the Q+A document that was published on Monday, September 23 and subsequent email; however, the students have freedom to utilize whatever HVAC system they choose as this is not something that will be part of the evaluation criteria.

Q: Are we allowed to erect more columns if the bridge is bridged? For example, the staircase area.

A: This is permitted if it needed to accomplish the student's design intent.

Q: Does the organizer require a lightning plan to show the location of the power outlet?

A: No need to show location of power outlets.

Q: Regarding materials such as paint, wood, do the organizers require any brands?

A; Students are free to select anything they choose here.

Q: Can we design the workstations with electrical outlets on the floor?

A: Yes, assumptions can be made regarding accessing power from the floor.

Q: Can you please provide details on the client celebration area in the reception space? What is the purpose of this space?

A: As mentioned in the program document, *“This is a place to celebrate client campaigns through different mediums (digital, physical, artwork, logos, videos, packaging, placards, etc.”* In essence, this is a way to feature and celebrate the clients and campaigns NEXT has implemented for their existing clients and could be seen as new/potential clients enter NEXT. The students have creative freedom on how they would like to express this.

Q: There is no janitor's closet/service sink visible in Revit. Are students required to add one?

A: No, assume this is in the out of scope area.

Q: When the NEXT program states "NEXT requires the adjacency of the Creative and Digital teams and the media team should be a satellite to the Creative team." What does "satellite" entail?

A: In close proximity – in the surrounding areas vs. another floor, etc.

Q: On the West side of the plan, underneath the stairs, there is a space without a clear entry. What is the use of this space?

A: Students shouldn't concern themselves with this because it falls within the out of scope area.

Q: In the REVIT file, there is a 16" counter top that runs on top of the 3' partition wall and butts up against the curtain wall, (which is actually offset 2'7" from the floor, blocking about 5" of the window) see images below. The area is immediately outside the mens' bathroom on floors 6 -7 and covers space between the first two sets of columns. Then it ends, leaving a gap between the 3' partition wall and the curtain wall glazing supported by the exterior brick wall along the rest of the periphery of the building. Can we continue the counter like it started by the restroom? Could we also lower the partition wall so it doesn't block the window--2'7" offset instead of 3'?

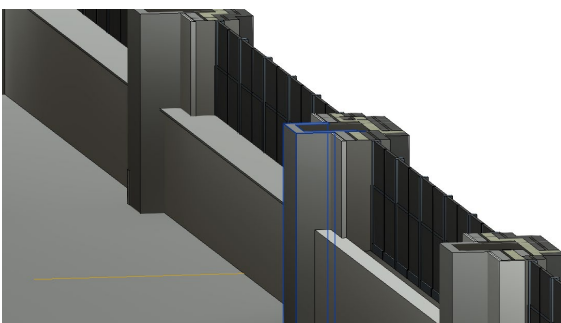

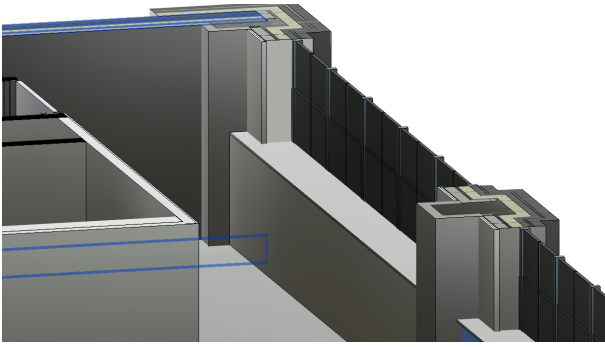

A: Yes, the counter can be continued if you wish to do so. No, the partition may not be lowered.

Q: In regards to the REVIT file --the window tint/glaze is very dark on the windows of the office and doesn't let any natural daylight into the building. Can this be changed in order to let light inside the space?

A: Yes, the window tint may be changed to whatever you wish – just the windows themselves may not be altered.

Q: What is the building classification of the building (Type II or Type III???)

A: The building classification is Class A. We are unaware whether type II or Type III

Q: Can we change the location of the doors to the bathrooms?

A: The bathroom doors should remain as is and the bathrooms are considered out of scope.

Q: Are we able to add restrooms or reconfigure existing ones?

A: The existing bathrooms are considered out of scope and shouldn't be changed; however, if the student wishes to add a new bathroom to meet their design intent they may do so. This is not a required element.

Q: Would it be possible to submit a section of the building in PDF?

A: We do not have a building section to provide.

Q: What is considered a client team? We see the requirements for the space on page 21, but when it states: "In close proximity to each of the four client teams, a client display area should be included to provide brand and product inspiration to these teams," it implies that the client teams are located in groups. However, it is unclear which employees listed on page 21 constitute each team. For example, do all four directors sit together, or does each director sit with their respective client team? Would this be 4 art directors designated to a brand

A: Assume there are four cross-functional teams for each client. Some of the directors work closely together as stated in the program as well as clarified in the Q+A that will be posted and should be closer to one another and these directors would work with all client teams.

Q: Are students allowed to use furniture/systems from Steelcase that are subsidiary's?

- AMQ Solutions
- Coalesse
- Halcon
- Orangebox
- Smith System
- Viccarbe

A: Students are permitted to use and products from any of these Steelcase owned brands as well as any of the products from companies that Steelcase partners with. Any products from any company shown here <https://www.steelcase.com/furnishings/> on the Steelcase website are available for students to use.

Q: My student envisions creating an innovative outdoor space while preserving the building's original exterior façade. Their idea involves removing the existing windows and constructing a new exterior wall with updated glazing set back from the original façade. Is this approach acceptable/feasible, acknowledging that we will need to thoroughly investigate structural integrity, and other considerations such as weatherproofing and energy efficiency?

A: Unfortunately, this would be considered out of scope. Since NEXT is a tenant of the building and leasing the space as opposed to being the owner of the space, it wouldn't be permitted to make this modification to the building.

Q: Column sizes are typical: 2'x2'

A: The actual column sizes should be the size as shown in the drawings.

Q: Window Cil is at 3' and all windows are 7'3" high, however, window width differ per column distance, correct?

A: Actual window width should be as shown in the drawings.

Q: There is no dedicated location for the monumental staircase. Students will pick the location as per their design needs, correct?

A: Correct.

Q: The skylight can be placed anywhere on floor 7 ceiling, per design needs, correct?

A: Incorrect. Please see the Q+A that has been published with questions through 9.20.24 (pages 10 and 12).

Q: There are some existing duplex/quadruplex and lights on the floor. Are they required to be retained?

A: No

Q: The skylight is floating above the building in the revit model and doesn't seem to want to move down. Should we infill with a solid between the top of the building and the base of the skylight to close that gap? Or another suggestion?

A: Yes, if the skylight is being used (see prior published Q+A), please infill with a solid as you've suggested. If not being used, consider the roof to be a continuous solid surface.

Q: Are there designated HR employees within the Operations Department? Or are they all off-site at the main office?

A: Assume HR employees are at the headquarters location in New York.

Q: There is what appears to be a metal plane floating up in the space that was meant to conceal some HVAC/plumbing infrastructure. Can it be deleted? If not, what is it and how should we address it?

A: Yes, this may be removed.

Q: How large can the punch out/opening to 7th floor be for the staircase? Can we create a larger opening than is required, for the stairs? Can there be an atrium and/or balcony if all programmed space is accounted for?

A: The size should be determined by the students; however, students should assume there are structural elements within the slab of the floor along the column lines that must be preserved for structural integrity. Therefore, any holes in the 7th floor slab for the monumental staircase and/or creating a balcony effect, they must be within the column lines and not cross them.

Q: Students are noticing a lot of "partner" furniture on the Steelcase website (coalesces, West Elm, Blue Dot...). Is there a maximum percentage for the use of "partner" furniture versus Steelcase?

A: There is no maximum. Students are free to use as much or little products from Steelcase, Steelcase owned companies (like Coalesse), or any of the independent Steelcase partners brands. Any products from any company shown here <https://www.steelcase.com/furnishings/> on the Steelcase website are available for students to use.

Q: How are the individual team members divided among the four client brands? Is there an org chart that describes who is on what cross functional team? Do the client brand teams need to co-locate versus sitting within their department?

A: You should consider the client teams as a cross-functional teams. Each client (core team) consists of an account executive, copywriter, and art director. They should be co-located. At times, the team will expand to include other individuals from any department and they will transition to their team meeting room. Everyone else would be co-located within their departments and consider the agencies we have suggested in the program document and all published Q+A...including Q+A that will be published on Monday, October 30.

Q: Are the (4) Account Execs, Art Directors, and Copywriters dedicated to one brand or shared?

A: See above. One of each of these make up a core team for each of the four clients.

Q: Do the huddle rooms have to be fully enclosed? What makes the difference between a huddle room and an in-between meeting space?

A: If you read the intended function of the huddle room it says it is “mostly used for heads-down work where NEXT employees will concentrate to write a client brief or create/write copy for a campaign.” We will leave it to the students to discern if fully enclosed or not helps accomplish this objective. An in-between space is a brief “touch-down” space that takes advantage of unused/available space in the plan for individuals and/or small impromptu interactions where distractions are not a concern.

Q: Can we have more than the number listed for the rooms? I.E. having 5 huddle rooms, if space allows.

A: Yes, if all the required spaces are accomplished and you have the available space, this is permitted.

Q: What does the media department being satellite to the creative department mean?

A: In close proximity – in the surrounding areas vs. another floor, etc.

Q: Can we break up the SF of the product resource room into two separate spaces?

A: If the intended use of the space can be accomplished and all other required spaces in the program are met, this could be permitted; however, the intention is to have this in close proximity to the creative team so you’d want to consider how this is accomplished if breaking into two spaces.

Q: Does the area within the South side of the NIS core (where a door was added to the utility chase and a wall removed, need to be accessible with an open hall (ie not blocked off by a room)? Like the North one with a path of travel to the egress stair? I’m assuming the area will still be not in scope?

A: Please see the response to a question on the Q+A that was published on 9.23.27 (pages 13 and 14). It addresses this situation, and yes, this area is considered not in scope.

Q: In what ways can students express their unique concepts within client-based branded environments?

A: Any way they choose while also celebrating the brands these client teams represent. They have full creative license here.

Q: Can we change the windows style?

A: The window style may not be changed to maintain a cohesive aesthetic from the exterior of the building.

Q: Regarding wall partitions, should the partitions be connected to the columns only?

A: Our recommendation is that walls be connected to the columns. For walls that engage with the perimeter, we recommend that students consider walls along the column lines. Walls at the window mullions would be much more involved to detail and execute than walls at the columns. Please see the photo of the window detail for reference below as well as the illustration of the issue. Though we do not recommend, it would be permitted if this is what best meets the student's design intent/needs for their project.

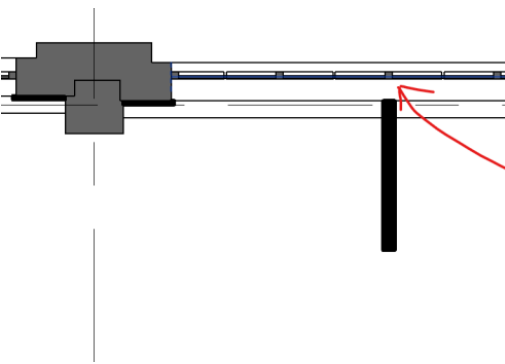

Q+A QUESTIONS + ANSWERS – Questions submitted through September 20, 2024

Q: We are participating but I wondered about the student registration because in the past we were only allowed to submit 2 projects. Is it open to all students now? Thanks.

A: We ask to have EVERY student who is participating in the competition (ie: doing the project in studio as part of the class curriculum) to register for the competition...this is how we know how many total students are participating in the competition from all of the programs.

From all the students participating, we ask each program to jury the submissions and select the (top two) projects into the competition for distribution to our panel of judges. We allow (2) projects per independently taught studio. For large programs that have 70 or 80 students spread across three independently taught studios, they would submit (2) per studio for a total of (6).

Q: I was curious about the four key client brands mentioned - ("In the NEXT Chicago office, we have four key clients (fast food chain, shoe brand, beverage company, and a consumer-packaged products company)".

Will these four brands be defined? Or are students allowed to assign a real brand identity to each category? For instance, Fast Food – McDonalds, Shoes – Nike, Beverage – Coke, etc. Or should each brand identity be fictional to avoid trademarks issues?

A: As mentioned in the NEXT program document, the client brands can be generic/fictional or the can be a real brand as you have indicate below. We do not anticipate any trademark issues because these projects are internal to Steelcase and are not used for any commercial/marketing/sales purposes for Steelcase. If a real brand is used, make sure the TM is clearly identified on any reference or logo.

Q: Could you verify that the main entrance/access to Level 6 is on the left side of the building where the elevators and egress stairs are located.

A: Yes, the main entrance access to Level 6 is by the elevators as you have stated.

Q: Can walls be placed up to the window mullions or can they only go to the support columns in between the windows?

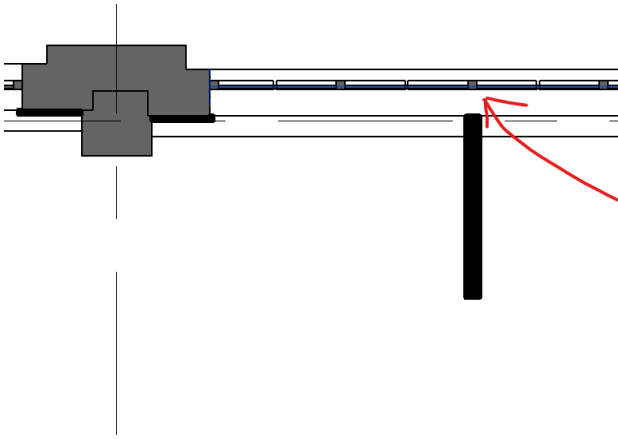

A: Yes, this could be accomplished; however, we wouldn't recommend. For walls that engage with the perimeter, we recommend that students consider walls along the column lines. Walls at the window mullions would be more involved to detail and execute than walls at the columns; however, are permitted if this is what best meets the student's design intent/needs for their project.

Q: Can the floor of Level 7 be cut to create an open to below mezzanine effect?

A: Yes, the 7th floor may be cut to accomplish this and will need to be cut to accommodate the required connecting, monumental stair between the 6th and 7th floors.

Q: In looking at the building in Google Earth, students noted that there appears to be a greenspace on the roof? If accurate, is that an area they could integrate into their design proposals?

A: The roof should be considered out of scope for this project as there is no access other than mechanical access and that is not part of the NEXT leased spaces within the building.

Q: Since level 6, 7 are on the top floor, if we want to introduce skylight, can we cut through the roof?

A: Yes, this is permitted and if you do a google or google earth search you will see that a skylight was added to this location; however, we removed it when returning the building to its original condition. A skylight can be added if it meets the student's design intent; however, this is NOT a required element and will not be part of the evaluation criteria. However, if a student does choose to include a skylight, it should be of similar size to what is found online in researching the building and MUST meet all local codes and restrictions if incorporated.

Q: If we would like to design a monument stair or some vertical elements, how much floor plate can we cut?

A: Actually, a monumental staircase must be included per the requirement shown on Page 27 of the Contest Overview and Program document. Regarding how much floor plate may be cut, the size is up to the student's discretion; however, all local codes and restrictions must be met.

Q: For submitting, do I also need to go through a registration process to prove my faculty appointment with the school is active?

A: Faculty do not need to use the link to register themselves. That was accomplished by responding to our email informing us of your intention to have your students participate. We only require students to register themselves (individually) using the link we provided and available on the NEXT website.

Q: In the model, the skylight is covered. Is this something that the students can remove to expose the skylight, or will the model be updated?

A: Yes, this is permitted and if you do a google or google earth search you will see that a skylight was added to this location; however, we removed it when returning the building to its original condition. The skylight can be added back if meets the student's design intent; however, this is NOT a required element and will not be part of the evaluation criteria. However, if a student does choose to include the skylight, it should be the same size to what is in the Revit model or found online in researching the building and MUST meet all local codes and restrictions if incorporated. We will not be updating the Revit model since this is not a required element for NEXT.

Q: Could you let us know what you mean by consumer packaged product company? Would coca cola count as one as they own many businesses?

A: I would encourage your students to do an online search of consumer packaged goods or consumer packaged products...there are many examples and definitions of what these are. Coca-Cola is an example from the many options; however, not sure you'd want to use two beverage companies if there are more options available. However, it is completely up to the students what brands they select.

Q: For our our fast-food chain we selected: Dunkin Donuts –
Beverage Company: Coca-Cola with a focus on Dr Pepper
Shoe Brand: Vans
Consumer Packaged Product Company: TBD
Are these expected?

A: There all seem appropriate if these are the student preferences. We have no expectations of what brands are used – just merely the types of brands. For your Dr Pepper example, they are not a Coca-Cola company, they are owned by Kuerig Dr Pepper.

Q: Can you please explain the highlighted portion from the program below:

"We serve these clients with a restlessness and dissatisfaction with the conventional; therefore, we must create an environment for our NEXT Chicago team where they can bring their entire selves to work and spawn breakthrough creativity."

A: It means they consider themselves to be more creative than their competitors (ie: other agencies) and they seek to provide unique campaigns to their clients that are not predictable.

Q: Please confirm the meaning of the highlighted portion from the program below. Does this mean the student can use actual real brands, and include images in their presentation?

"PLEASE NOTE: The company brand and culture is up to the interpretation of the student. For each of the client teams, the student may make each of the four primary clients generic and/or they can select any brand of their choosing that matches the client types and incorporate that into the spaces they design for NEXT and their employees. This is completely up to the student's discretion."

A: Yes, they can use real brands and images (if they reference/include the trademark on the logos) if this meets their design intent or they can choose to feature a "generic/fictitious brand" if they choose. The decision is completely up to them.

Q: Does the **project logo** fall under the Official Rules AI use notation? The rules note includes concept development, concept statements and inspirational images but it does not mention the logo specifically.

A: The project logo would not fall under this since it is not mentioned.

Q: Can students create **access to the rooftop** from the 7th floor with the intention of creating an outdoor space on the rooftop?

A: No, the rooftop is considered out of scope for this project.

Q: I have a question in regard to working on the REVIT file. When I click on the Consultant Communication: Floor Plans (Consultant Background), no walls or furniture will appear when I place them. That being said, what plan/view/ layout is the best for us to design in or what settings should we modify?

A: I'd suggest checking the parameters of the wall to see if it has any base offsets or base constraints (that's for walls):

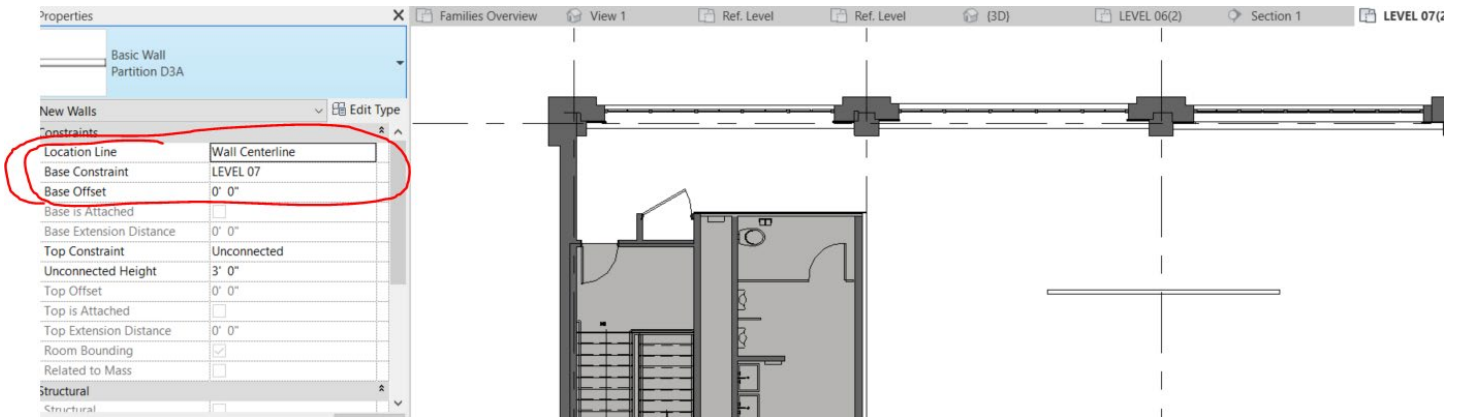

For furniture, I would suggest changing/editing/creating the/a View Template that suits your needs.

It can be changed on the Properties tab > Identity Data > View Template, you can edit the templates or create a new one there.

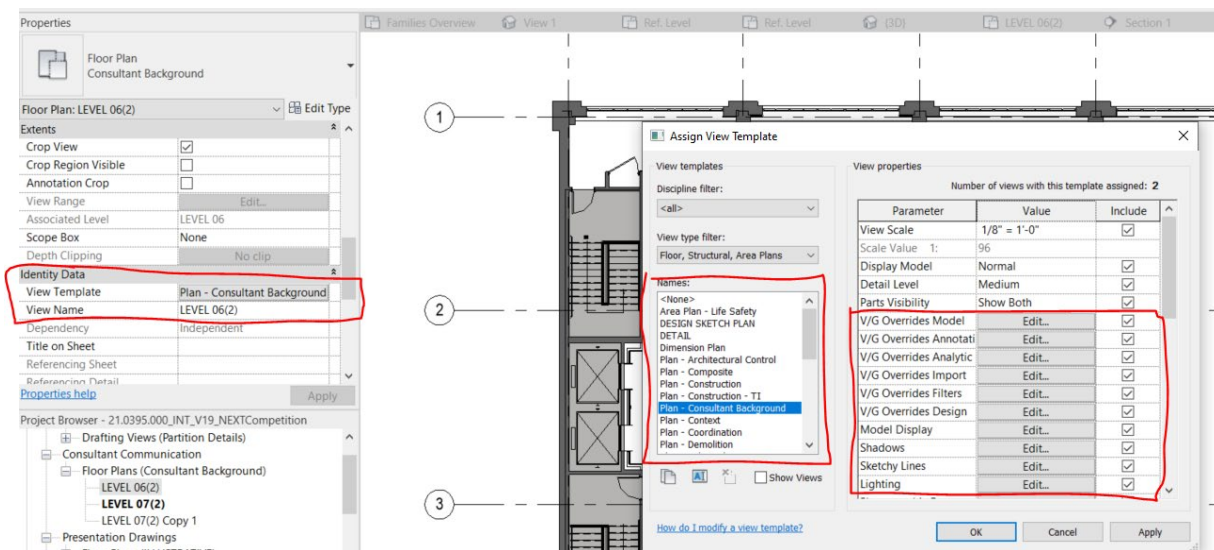

I suggest you keep working on the Floor Plans (Consultant Background) LEVEL 06 and LEVEL 07, or you could create a new view as long as you meet the competition requirements/guidelines.

Q: What amount of square footage are we allowed to go over/under as written in the deliverable? (For example, the Lactation + Wellness room are both set at 80-100 sq. ft., if allowed, how much could we go above or below the set square footage?)

A: The SF totals for the required spaces are suggestions; however, deviations may be permitted. We wouldn't suggest making these spaces smaller than the suggestions from a user experience POV for intended use; however, increasing the sizes is permissible if it meets the students design intent. However, if increasing the sizes, all required spaces need to fit approximately into the space.

Q: Are the required spaces allowed to be split between two different locations? (For example, can the 1000-1500 sq ft work cafe be split and placed on two different floors)

A: The spaces may be split if this meets the students intent and the stated intended use of the space is accommodated. In your example, if splitting the WorkCafe into two spaces on each floor, the student will need to consider how this stated use is accommodated:

“This area also serves as an “all hands on deck” for weekly, brief “town hall” updates to all employees, to host guest speakers to all employees, or to debut new campaigns to everyone. Need to consider how displayed information will be available to everyone.”

Q: How much sq ft of floor space can we take out of the 7th floor?

A: Regarding how much floor plate may be cut, the size is up to the student’s discretion; however, all local codes and restrictions must be met and all of the required spaces in the program must be accommodated for over the two floors.

Q: Does the elevator provide access from ground level for all visitors or is card access/swipe used for Next employees only?

A: Elevator access is from ground level lobby.

Q: Do you have any more information on the client type "consumer packing companies"- we were researching companies such as Graphic Packaging, but wanted to make sure we are on the right track with that client group.

A: The client type isn’t a consumer (packing) company...it is a consumer-packaged products company. I would encourage your students to do an online search of consumer-packaged products and/or consumer packaged goods...there are many examples and definitions of what these are.

Q: Can you provide the slab to slab height/ceiling height in the project space? Is the ceiling totally flat or are there beams that need to be considered in planning the space?

A: Slab to slab (top to top) is 11’-0” with 10’-3” clearance and the ceiling is flat.

These are the dimensions:

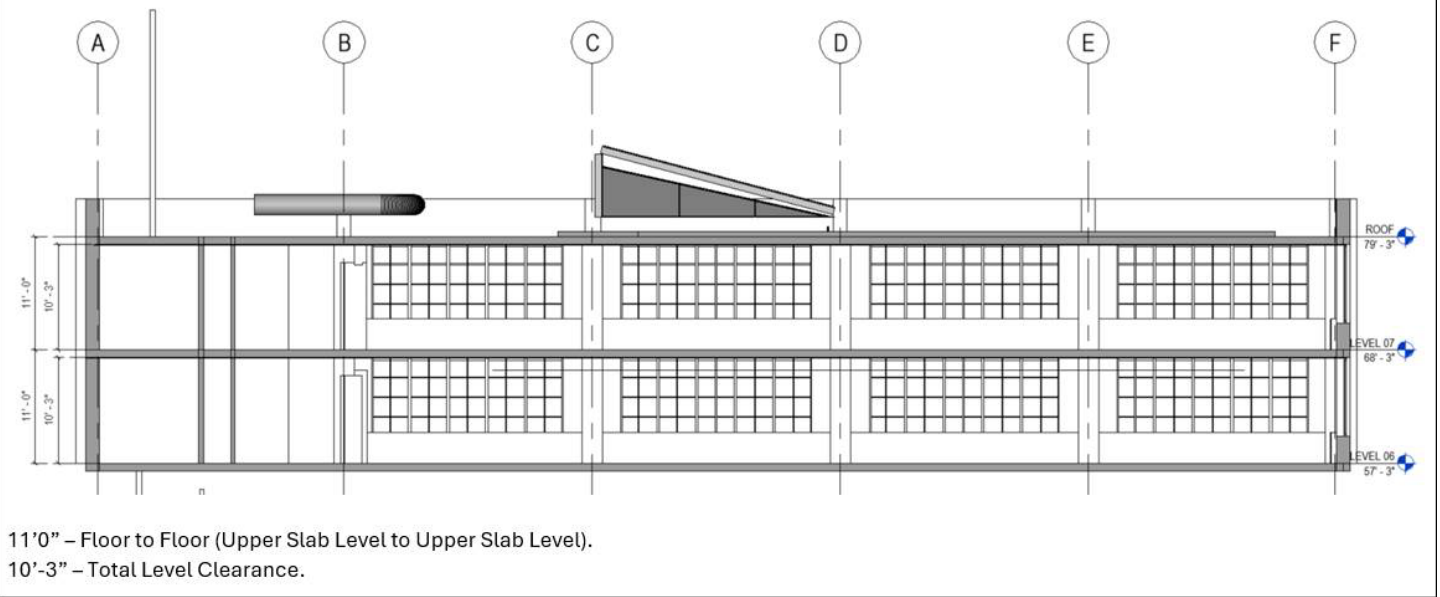

Q: Please provide specifics about the HVAC, such as is the duct work near the ceiling and/or along the exterior walls.

A: I have attached a few photos of the existing HVAC system as it is currently installed:

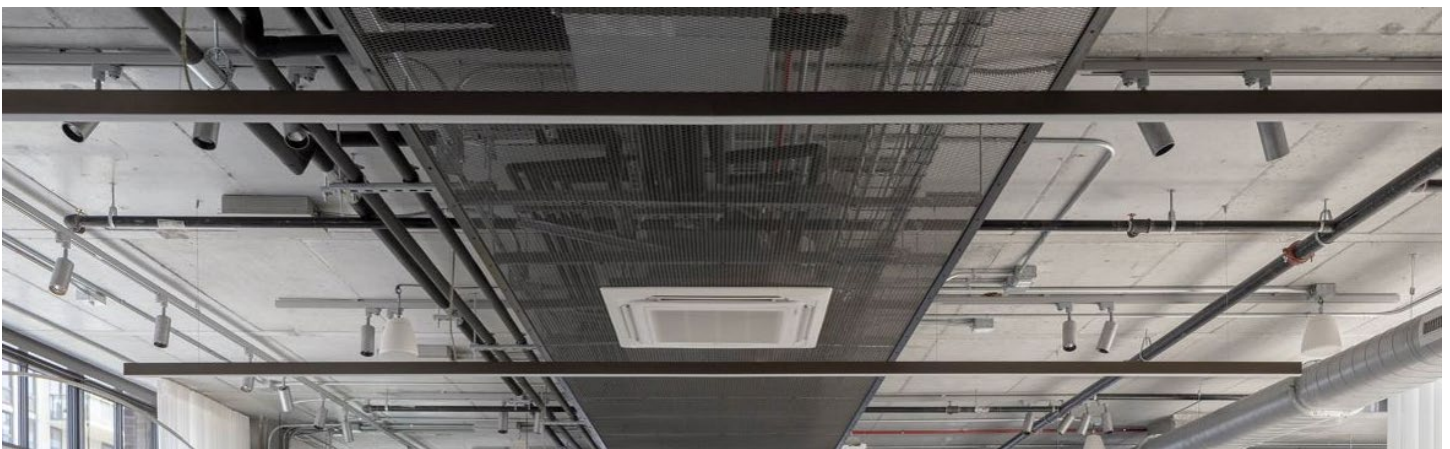



Q: Are interior photographs of the existing space available? Are there photographs of the views to the north, east and south?

A: We do not have photos of the views to the north, east, or south. I would consider having your student do a google earth search.

Q: What are the cardinal directions of the plan? Are the elevators and stairs on the west side of the building?

A: Yes, the elevators are on the west facing side of the building.

Q: Is the client celebration area simply a promotional display space for the advertising company?

A: If you are referring to the Client Display Areas, these are intended to provide brand and product inspiration to the NEXT employees on each of the client teams. How they accomplish this is up to the students whether they want it to be digital, analogue, physical products, etc. depending on the brands the student chooses and the products they offer.

Q: How are the interior columns finished now? Are they faced in concrete in a square profile?

A: Here are photos of the columns within the existing space:



Q: Regarding the Production and Resource Area, assuming the receptionist will need access to a possibly noisy, active area, could the mail area and a supplementary copier be placed near the reception area? That way the Production and Resource Area could be placed in an area that isn't disruptive to the clients in the waiting area. (If not, this does provide a welcome challenge to locate this area in a way that provides access by the receptionist, assuming he/she will need to help with mail dispersal and copying for other likely assigned tasks, while separating a possibly noisy, active area from client exposure.)

A: This decision is completely up to the students depending on their design intent and they are welcome to make any assumptions on who and how these spaces will be used when locating them in their plans.

Q: Is there a door for the men's restroom on the 6th floor? There is not one currently shown on the plan.

A: Yes, the door to the 6th floor men's restroom is the same as shown on the 7th floor. This was an error in the plans we were provided.

Q: Are the existing skylights shown in the Revit file visible through the 7th floor ceiling system?

A: The existing skylight is visible through the 7th floor ceiling in the actual built condition; however, we removed it when returning the building to its original condition. The skylight can be added back in if it meets the student's design intent; however, this is NOT a required element and will not be part of the evaluation criteria. However, if a student does choose to include the skylight, it should be of similar size to what is found in the drawing or searching online in researching the building and MUST meet all local codes and restrictions if incorporated.

Q: It was mentioned that students can select a specific brand that matches the client type. If a brand is selected by the student, are they allowed to show this brand's logo in their renderings?

A: Yes, they can use real brands and images (if they reference/include the trademark on the logos) if this meets their design intent or they can choose to feature a "generic/fictitious brand" if they choose. The decision is completely up to them.

Q: Is access to the roof and the potential to use the roof as an additional wildcard space an option?

A: The roof should be considered out of scope for this project; therefore, it should not be considered as a wildcard option.

Q: Is there a maximum size of area if a student wants to have a glass floor in certain spaces?

A: This should be determined by the student if they wish to incorporate. They will need to make sure it meets all local codes and restrictions if incorporated.

Q: 6th floor - a student wants to know if they can remove the wall that extends from the ladies room to the exterior wall to make available the area behind the ladies room.

A: Yes, that would be permitted.

Q: Will all Q&A be published for everyone????

A: Yes, we publish all questions asked to everyone.

Q: Do we only need to call out the specific project teams ("neighborhoods")? Should we assign each team member/employee a desk?

A: No need to assign desks. Calling out the team spaces or neighborhoods is acceptable.

Q: How much of the 7th floor can we remove within the structural bays?

A: This should be determined by the student. They should make sure everything meets all local codes and requirements.

Q: Can we add another elevator only for NEXT employees to use/for accessibility purposes?

A: The existing elevators can be used for access to both floors; however, if a student wishes to include another lift they may do so if this meets their design intent; however, it isn't required.

Q: Can we install multiple staircases?

A; Yes, this is permitted if it meets the student's design intent and as long as all local codes and restrictions are accomplished and all required spaces in the NEXT program are accomplished.

Q: Do we need to think about security/keycard access/consider restricted general access on the 7th floor (or the floor without a reception desk monitoring visitors?)

A: The students should consider which floor will be their main entry for design intent purposes and make assumptions for card key access to the other floor since only one receptionist.

Q: Can we edit or expand the skylight? (ex: add more skylights)

A: The skylight (if used, see Q+A document that will be published on 9.23.24) may not be expanded and no additional skylights may be added.

Q: Can we "rebuild" the columns?

A: The columns may not be altered structurally; however, they may be covered/wrapped with any material if that meets the student's design intent.

Q: Are the columns concrete or steel?

A: Concrete.

Q: Is it possible to add structure?

A: The student may add structure internal to the NEXT occupied space; however, the building architecture may not be altered.

Q: Do lighting fixtures need to be Steelcase partners only or is it open to other manufactures and companies?

A: Lighting choices are not required to be Steelcase and/or Steelcase partner companies; however, there are many great choices from Steelcase partner brands that you may wish to consider.

Q: Can the green roof be accessed? Is it a community space or a space that could only be used by NEXT employees?

A: The roof should be considered out of scope and not accessible.

Q: Can we add a rooftop terrace?

A: No, the roof should be considered out of scope.

Q: Are the HVAC systems on the roof?

A: Yes. If your students do a Google Earth search of the location, they will see the HVAC systems on the roof.

Q: Do acoustical products need to be Steelcase partners or can we use other products?

A: If this question is related to demountable/reconfigurable wall products being included then yes, they should be from the Steelcase Architectural Walls portfolio of products.

Q: Is the skylight available to use in the project?

A: The existing skylight on the 7th floor roof may be used if this meets the student's design intent; however, it is not a required element. We removed the skylight to return the building back to the original architecture of the space prior to "NEXT" occupying the space. If the skylight is used, it may not be altered in any way.

Q: Are we designing the space for all 4 key clients in mind, or can we choose just one of clients to focus on?

A: All four key clients as stated in the program document:

"There are four key clients the NEXT Chicago office supports (fast food chain, shoe brand, beverage company, and a consumer-packaged products company) and it is important to consider a "branded environment" for the client teams that support these clients for them to "live their brands."

Q: In the program under "NEXT Spaces" in the "Workstations" column it says that we are to include 38 individual workstations and 2 visitor workstations. When you add up the number of people in each department (minus the

directors who get private offices, and 2 visitor stations) the sum is 37. Are we to assume that the 38th space becomes a third visitor workstation?

A: The NEXT spaces need to accommodate a total of 45 people (42 NEXT employees and three flexible spaces). If you take the number of employees (minus the four who will receive private offices), the number should be 38 who receive a workstation. Add in the four assigned private offices and your at 42. Add in the flexible private office and the two flexible workstations you are at 45.

Q: Are the client display areas strictly for employee brainstorming or can they also be utilized as a display of ideas to the clients?

A: This can be decided by the student based on their design intent. However, the intention of this is to provide brand and product inspiration to the NEXT employees on each of the client teams. How they accomplish this is up to the students whether they want it to be digital, analogue, physical products, etc. depending on the brands the student chooses and the products they offer.

Q: Should the logo be designed for the international NEXT brand or for the Chicago location specifically?

A: This can be decided by the student based on their discretion. Both are acceptable.

Q: Some of the existing walls do not go to the ceiling in Revit. Is this correct or should all existing walls go to the ceiling?

A: Assume all go to the ceiling.

Q: On the floorplan for the 6th floor, are the protruding elements along the west wall drinking fountains? If not what are they?

A: Assume they are drinking fountains.

Q: On the 6th and 7th floor on the south west side of the building near the stairwell, there is a blocked off room. On one of the floors this room has a door inside but there is no access to this space on either floor. Is this used as a utility space or is it from a lower level? What is it's purpose?

A: There was an error in the plans we received from the building. Please see below. A door should be added to the 6th floor to match what is shown on the 7th floor. This is a utility space. The wall shown on both the 6th and 7th floors should be removed:

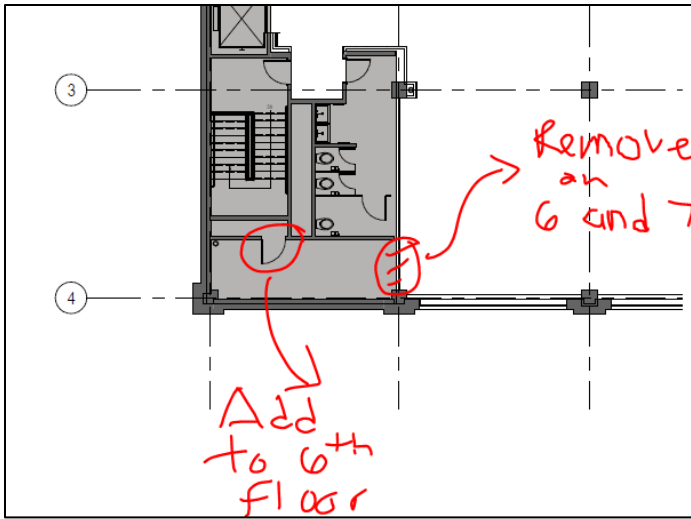

Q: Can the 6th Level ceiling and 7th level floor be cut and left open in some areas to create higher voluted ceilings or balcony architectural effects?

A: Yes, this can be accommodated if it meets the student's design intent as this is the floor that will be cut to include the monumental stair. All local codes and restrictions must be met if including the additional floor cuts.

Q: Are there any regulations with plumbing such as plumbing walls or specific distances that plumbing needs to be from a respective wall? (this would be for any sinks, dishwashers, drinking fountains, or other water features that might be considered)

A: This should be researched by the student to understand the local codes and regulations.

Q: Should we allow private spaces for the Art Directors in the creative department since they are directors but are not assigned to a private office space?

A: This can be determined by the student based on their design intent of the space.

Q: The client display areas are projected to be near each client team but the "teams" listed are not separated by clients. Is there supposed to be established areas for each of the 4 clients in addition to the employee teams (creative, digital, media, etc)?

A: Assume there are four cross-functional teams for each client.

Q: What do you want students to gain the most from out of this experience?

A: Designing for a commercial workplace and making product selections based on the client needs.

Q: Should there be any specific rooms that follow ADA codes?

A: The NEXT workplace should accommodate for all codes and requirements including ADA.

Q: By “custom” does this mean we can find our own furniture online from different office furniture systems; or if we are using “custom” does this literally mean custom? We are only allowed to make up our own custom furniture?

A: The spirit of this statement is meant for “custom designed furniture” by the student as we feel the Steelcase portfolio and family of partner brands accommodate for a wide range of options. However, this is an interior design competition – not a furniture design competition and that is where the focus and amount of time should be spent.

Q: In the official rules, state that we are allowed to use 20% of custom pieces, however, it also states that when we make our custom pieces, it should be economically feasible. How do we know what's economically feasible for this project? How do we budget these materials that will be used?

A: Please see above. Do not fixate on budget – we haven’t provided an actual budget for this competition and the fictitious client. The spirit of this regarding most actual clients do not have unlimited budgets and cannot afford considerable amounts of custom-made products.

Q: Can you explain more about the "in-between" spaces?

A: Small, informal areas the employees use between meetings or activities or to take a break. They can be located between two office destinations, such as in a wide hallway outside a meeting room or café. They serve as a place to stop for a few minutes between two activities or to have a brief impromptu interaction.

Q: What are some common mistakes or challenges students encounter during the competition, and how can they be avoided?

A: Watch the published recording of the call we will have with the faculty participating. The date of the call is October 1.

Q: Are video walk-throughs/renderings allowed in our submission (counting as one of the required renderings)?

A: This is permitted; however, it should be provided in the submission as a QR code that takes the viewer to the location to be viewed online...not as a separate file submitted. The only risk is whether the viewer actually takes the time to do so. This is not a required option; however, is perfectly acceptable.

Q: Are there any specific sustainability certifications, standards, or regulations we should follow or is it just a general overall sense of sustainability wherever possible?

A: We are not making requirements here. This is up the student; however, sustainable choices are always great choices.

Q: When it's talking about the square footage required for each space, is that just a minimum requirement, or do we have to follow it exactly?

A: These are guidelines/suggestions. There can be deviations; however, the student cannot decrease the amount of space shown in the range and if they increase, they must ensure all of the required spaces are accommodated for.

Q: The 6/7th floors are very similar. But one very small difference is a closet on the top left corner? Is that space something that can be altered? Or in general what is that difference about?

A: Consider the deviation on the 7th floor to be a storage closet and should remain as is.

Q: In the project guidelines they state that a minimum of 5 renderings must be "full bleed renderings." What does a "full bleed" rendering refer to?

A: This means the renderings should be large and be full page.

Q: For the 4 key clients they state the student may select a brand of our choosing, so does that mean we are able to include that brand's logo and such into our design as well for renderings of the client displays?

A: Yes, they can use real brands and images (if they reference/include the trademark on the logos) if this meets their design intent or they can choose to feature a "generic/fictitious brand" if they choose. The decision is completely up to them.

Q: For the wildcard space are there any specific requirement they are looking for, or do we have full creative freedom on this area.

A: Full creative freedom for this space.

Q: Is it acceptable to go over the provided square footage for the spaces?

A: These are guidelines/suggestions. There can be deviations; however, the student cannot decrease the amount of space shown in the range and if they increase, they must ensure all of the required spaces are accommodated for.

Q: When the design program say "client teams", does that mean all of the departments/all of the employees of the office?

A: Assume there are four cross-functional teams for each client.