



M#: 18-0101867

## Simple Sophistication

Introducing the Elective Elements floating shelf, a new light storage solution for private office and open plan environments.

With no visible hardware, floating shelves offer a clean and refined aesthetic, perfect for displaying books and accessories or allowing efficient access to personal tools.





Available in a range of veneer and laminate finishes, Elective Elements floating shelves come standard with a back panel and can be specified in modular or parametric sizes. A lower floating back panel can be ordered separately to complete the look.

## STATEMENT OF LINE

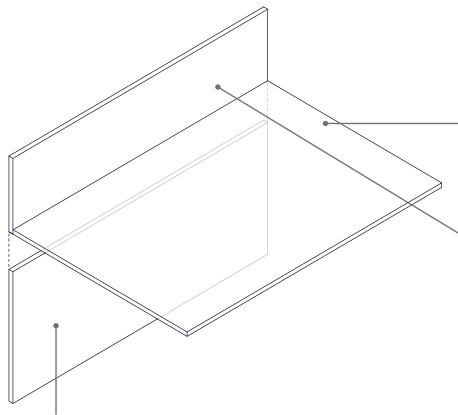

**Floating shelf** is offered in laminate or veneer, with a standard horizontal grain direction.

**Shelf back panel** (included with floating shelf) comes standard with a horizontal grain direction. Optional vertical grain laminate available; see *Specification Guide* for restrictions and full details.

**Floating back panel** (optional and sold separately) is offered in veneer or laminate, with standard horizontal grain direction. Optional vertical grain laminate available; see *Specification Guide* for restrictions and full details.

*Note: Floating shelf with back panel is intended for light load settings. Weight capacity is 18 pounds per linear foot. Shelf can be mounted in a structural wall mount application; not for use in panel-mounted applications.*

## DIMENSIONS

### Floating shelf with shelf back panel

Floating shelf depth	6" – 15"
Floating shelf and back panel width	30" – 120"
Shelf back panel height	7" – 48"
Shelf back panel thickness	3/4" or 1"

### Floating back panel

Width	30" – 120"
Height	8" – 48"
Thickness	3/4" or 1"

*Refer to SmartTools for parametric sizes, available in 1/16" increments.*

## SURFACE MATERIALS

For more information about available finishes, visit us online and view our *Specification Guide*.

# Steelcase®

Call 800.333.9939 or visit [Steelcase.com](http://Steelcase.com)

