

ACTIV | height adjustable bases

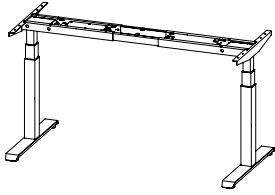

STATEMENT OF LINE



ACTIV-Pro
dual motor, available with 2- or 3-stage
legs in T or C foot style

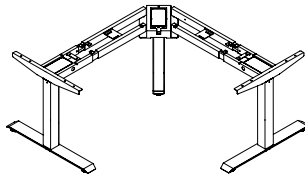

ACTIV-Pro3
3 legs/triple motor
90°/120° configurations

Worksurfaces

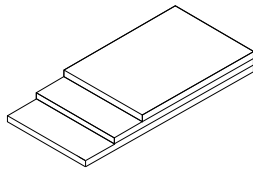

Linear

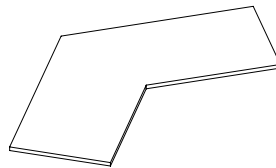

90°/120° (ACTIV-Pro3)

Privacy Screens

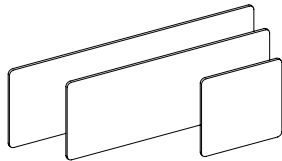

3F Screens

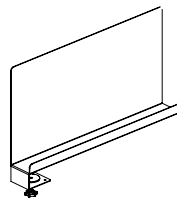

Side Screen

Accessories

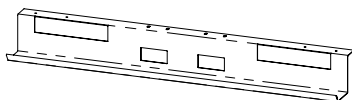

Wire Tray

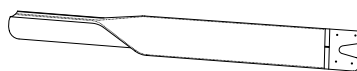

Soft Cable Management

FINISHES

Worksurface

Milk White
Maple
Teak
Walnut
Arctic White
Seagull
Ash Wenge
Clay Wenge
Acacia
Graphite Walnut



Screens

Briquette
Shadow
Ash
Pearl
Celestial
Verde
Tuscan
Saffron
Sand
Seafoam

Frame

Platinum
White
Black
Merle

Worksurfaces



Milk White
W2.1



Maple
W2.2



Teak
W2.3

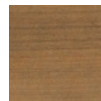

Walnut
W2.4



Arctic White
W2.5



Seagull
W2.6



Ash Wenge
W2.7



Clay Wenge
W2.8



Acacia
W2.9



Graphite Walnut
W2.10

Frames



Platinum
F1



White
F2



Black
F3



Merle
F4

3F Screens

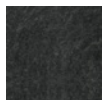

Briquette
FC1

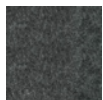

Shadow
FC2

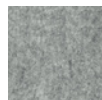

Ash
FC3



Pearl
FC4



Celestial
FC5

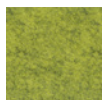

Verde
FC6



Tuscan
FC7

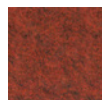

Saffron
FC8

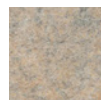

Sand
FC9

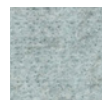

Seafoam
FC10

SPECIFICATIONS ACTIV-PRO/2-STAGE LEGS

Handset	Push button with 4 programmable settings
Safety	Anti-collision
Foot Length in Inches	22" and 28" for 24" and 30" deep worksurfaces
Legs	2 stage, available with T or C Leg
Leg Diameter	2.75" x 2.75"
Height Range (excluding top)	27" - 46.7"
Height Range (including top)	28" - 47.7"
Frame Width Expansion	width extendable 48"-72" in 1mm increments
Worksurface Widths	46", 48", 52", 54", 58", 60", 64", 66", 70" and 72"
Worksurface Depths	24" and 30"
Max Lifting Capacity	225 lbs
Base Weight Without Top	66 lbs
Gauge of Steel	2mm for inner tube and 1.5mm for outer tube
Speed	33mm/s
Standby Consumption	.2W
Active Consumption	Max 400W and Max 5A
Decibel Rating	50db \leq
Total Stroke	500 mm
Power Cord	9' cord length with standard NEMA 3 prong plug
Finishes	Platinum, White, Black and Merle
ANSI BIFMA	X5.5
Green Certification	SCS Gold
UL	UL962

SPECIFICATIONS ACTIV-PRO/3-STAGE LEGS

Handset	Push button with 4 programmable settings
Safety	Anti-collision
Foot Length in Inches	22" and 28" available for 24" and 30" deep worksurfaces
Legs	3 stage, available with T or C Leg
Leg Diameter	2.75" x 2.75"
Height Range (excluding top)	23.5" - 49"
Height Range (including top)	24.5" - 50"
Frame Width Expansion	width extendable 48"-72" in 1mm increments
Worksurface Widths	46", 48", 52", 54", 58", 60", 64", 66", 70" and 72"
Worksurface Depths	24" and 30"
Max Lifting Capacity	250 lbs
Base Weight Without Top	72 lbs
Gauge of Steel	2mm
Speed	38mm/s
Standby Consumption	.2W
Active Consumption	Max 400W and Max 5A
Decibel Rating	50db \leq
Total Stroke	650 mm
Power Cord	9' cord length with standard NEMA 3 prong plug
Finishes	Platinum, White, Black and Merle
ANSI BIFMA	X5.5
Green Certification	SCS Gold
UL	UL962

SPECIFICATIONS ACTIV-PRO3/3-STAGE LEGS

Handset	Push button with 4 programmable settings
Safety	Anti-collision
Foot Length in Inches	22" and 28" available for 24" and 30" deep worksurfaces
Leg Stage	3 stage
Leg Diameter	2.75" x 2.75"
Height Range (excluding top)	23.5" - 49"
Frame Width Expansion	120°: 470mm / 90°: 500mm
Worksurface Widths	Linear: 48", 60", 72" (see pricebook for 90° and 120° sizes)
Worksurface Depths	24" and 30"
Max Lifting Capacity	300 lbs
Gauge of Steel	Inner/Middle tubes: 2mm / Outer tube 2mm
Base Weight Without Top	113 lbs
Speed	38mm/s
Standby Consumption	0.2W
Active Consumption	Max 500W and Max 13.5A
Decibel Rating	50db≤
Total Stroke	650 mm
Power Cord	9' cord length with standard NEMA 3 prong plug
Finishes	Platinum, White, Black and Merle
ANSI BIFMA	X5.5
Green Certification	SCS Gold
UL	UL962

FEATURES



Choose 2 or 3 stage legs with T or C foot style



Linear, 90° and 120°



Seamless integration with ILINE



Standard handsets with 4 memory presets



Complete workstations: privacy screens, monitor arms, cable management, storage and seating

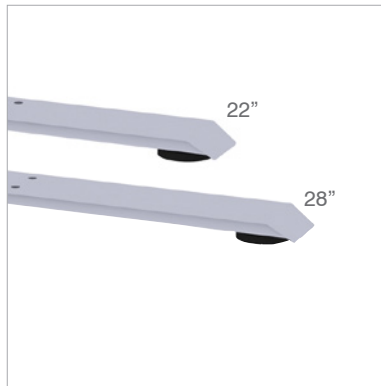

Two foot lengths support 24" and 30" deep worksurfaces

GYROSCOPE / ANTI-COLLISION TECHNOLOGY

ACTIV bases have built-in gyroscope sensors in their control boxes which can detect angle and speed changes on three axis, triggering the anti-collision safety feature. When activated, bases reverse direction for 2 seconds before stopping.

Reaction Time: 50ms-600ms

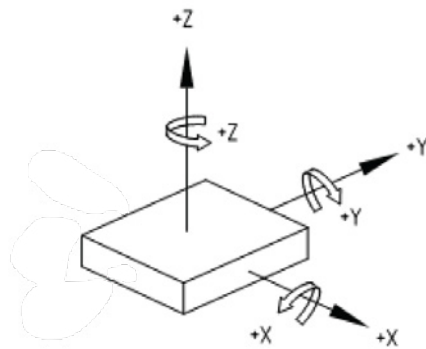

Gyro anti-collision technology senses changes on 3 axis

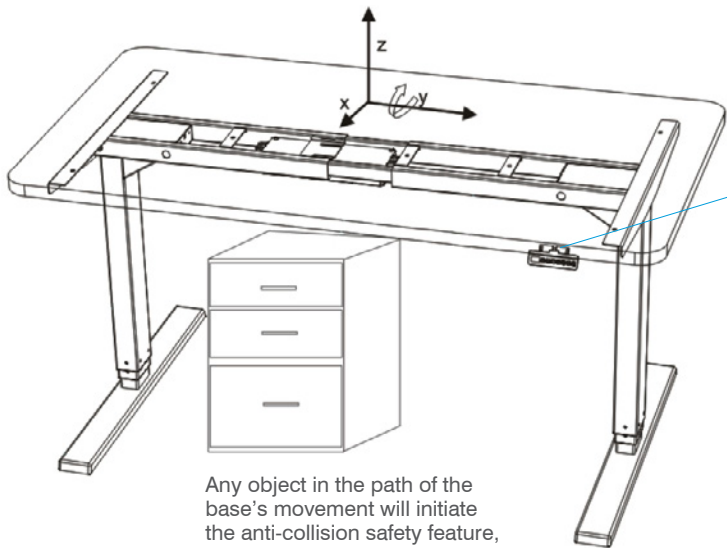

Sensor technology located in ACTIV control boxes

Any object in the path of the base's movement will initiate the anti-collision safety feature, reversing the direction of the base for 2 seconds

INSTALLATION TIME

ACTIV-Pro — 20 minutes per base, including worksurface

ACTIV-Pro3 — 30 minutes per base, including worksurface

CARE & MAINTENANCE INSTRUCTIONS

Wipe with a damp cloth using water or gentle, nonabrasive cleaner. For guaranteed safety, patch test with diluted cleaner before wiping entire surface. Wipe dry with a clean cloth.

WARRANTY

10 years, including parts and approved labor.

CERTIFICATIONS

ANSI/BIFMA X5.5-2014
Indoor Advantage Gold™

