

Steelcase

Airtouch® Lift Assist

User Guide

HEIGHT ADJUSTMENT

Paddle

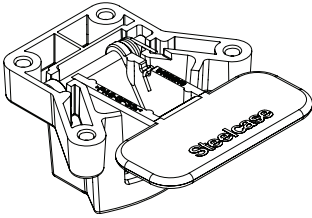

The worksurface adjusts via a simple paddle.

- Squeeze the paddle and pull up on the worksurface to raise the table.
- Squeeze the paddle and push down on the worksurface to lower the table.

Note: For a visual demonstration, please visit youtube.com/steelcasetv

Troubleshooting

Step 1: Check that the desk is not overloaded.
Weight capacity is 150 lbs.

Step 2: Check that the tension is properly adjusted.

- Squeeze the lift handle and raise the worksurface to its maximum height (fully extended).
- Remove adjustment tool stored on the underside of the worksurface and insert into lift assist gauge socket.

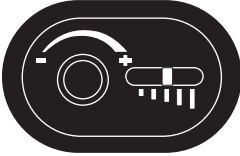

- Turn adjustment tool 10 to 20 rotations in the proper direction until adjusted to your lift comfort level.
 - A. Clockwise for more tension when the top is difficult to raise.
 - B. Counterclockwise for less tension when the top rises too fast or is difficult to lower.
- Recheck the balance of the worksurface and repeat as necessary.

Note: The lift system incorporates a clutch that will provide a clicking noise when the mechanism has been adjusted to its minimum or maximum setting.

Note: During initial install, after the table has been outfitted with the user's items (computer, flat panel monitor arm, task light, etc.) the table needs to be adjusted for the weight load. Use a cordless drill; reverse a screwdriver bit holder and use the 1/4" hex drive to adjust the lift assist gauge.

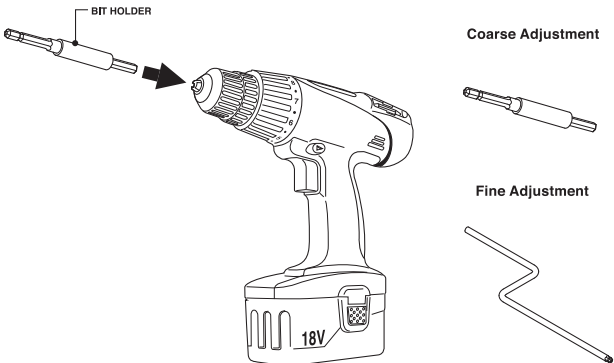

Workstation Design Tips

- Ensure that power cords for all accessory items – computer, lights, monitors, etc. – are of sufficient length to reach outlets throughout the range of worksurface height adjustment. Do not subject the cords to any strain while adjustment of the surface is taking place.
- Always check for proper operating clearance before placing any item on, above or below the worksurface.

Maintenance and Cleaning

Regularly clean dust and dirt from Lifting Columns. To ensure all surfaces are thoroughly cleaned, make sure the Lifting Columns are fully extended to their maximum height. Also, be sure to inspect the Lifting Columns for damage. Check all connections for both correct function and secure mounting.

Caution: A damp cloth is recommended. To protect the painted surfaces, use a cleanser that is not highly alkaline or acidic. A pH neutral product is ideal.

Note: Please do not move the desk without help. Refer to the guidelines at the end of the assembly instructions, or contact your facilities group for assistance.

Product Specification

Range of Adjustment	26" – 43" (660 - 1,092 mm)
---------------------	----------------------------

Glide Adjustment	1" (25.4 mm)
------------------	--------------

Distributed Weight Capacity	150 lbs (68 kg)*
-----------------------------	------------------

Tip: When calculating lifting capacity, subtract the weight of the worksurface.

Wire Management Included	No
--------------------------	----

Controller	Paddle
------------	--------

* Weight of Worksurface:

- Rectangular tops weigh 31 lbs – 62 lbs;
52"x29" tops weigh 56 lbs.
- 90° tops weigh 31 lbs – 72 lbs.
- 120° tops weigh 56 lbs.

Steelcase®