

Steelcase |  Microsoft



20-0148244

**Steelcase Roam Collection**  
system of mobile stands and wall mounts

Visit [steelcase.eu](https://steelcase.eu)

 [facebook.com/Steelcase](https://facebook.com/Steelcase)  [twitter.com/Steelcase](https://twitter.com/Steelcase)  [youtube.com/SteelcaseTV](https://youtube.com/SteelcaseTV)

Concept and Design / Steelcase  
19-E0000444 03/21 © 2021 Steelcase Inc. All rights reserved. All specifications subject to change without notice.  
Trademarks used herein are the property of Steelcase Inc. or of their respective owners.

**Steelcase**

## Take teamwork anywhere.

Steelcase® Roam™ Collection, for the Microsoft Surface Hub 2S family of devices, allows teams to come together—even when working apart. Co-developed with Microsoft, the Roam system of mobile stands and easy-to-install wall mounts supports large-scale collaboration—anywhere, anytime, any way.



### Bring Remote Teams Together

The Roam Collection enhances collaboration across distance and across devices. Bring remote teams together and enable large-scale teamwork where everyone can be seen, heard and actively participate in meetings—whether they're together or apart.



### Support Flexibility

The flow of ideas doesn't have to end when your scheduled meeting does—the intentionally approachable design of the Roam Collection of wall mounts and mobile stands provides the flexibility to support a variety of devices, to move and adapt in space and empower teamwork to happen wherever ideas do: anytime, anywhere, any way.



### Enable Active Collaboration

Collaboration fuels innovation. The Roam Collection allows teams more room for ideas and content sharing, and more opportunities to physically and emotionally engage in the creative process.

## A collection built to support collaboration—anytime, anywhere, any way.



20-0143120

### Wall Mounts

The Roam Collection of easy-to-install wall mounts makes any space more flexible, from small huddle spaces and conference rooms to private offices. It's building code-compliant, keeping the large-scale screens close to the wall—unobtrusive and inviting for a team to work together naturally.



20-0143110

### Floor Supported Wall Mount

The freestanding wall mount provides the option to safely and easily integrate the Microsoft Surface Hub 2S 85" into any room—without the worries of wall reinforcement and access to power and data. Mounting brackets enable legs to rest away from the wall, allowing any space to become a collaborative space without remodeling or new construction.



20-0143109

### Mobile Stands

The Roam Collection of mobile stands moves easily on smooth-rolling casters for on-the-go transitions throughout any space. Locking casters provide added stability and safety. The mobile stand was thoughtfully designed to help teams work effectively. The legs are designed to be the ideal circumference for hands to easily grip. On the 50" mobile stand, the storage tray keeps cables hidden and the back panel is useful to house various assets or presentation needs.

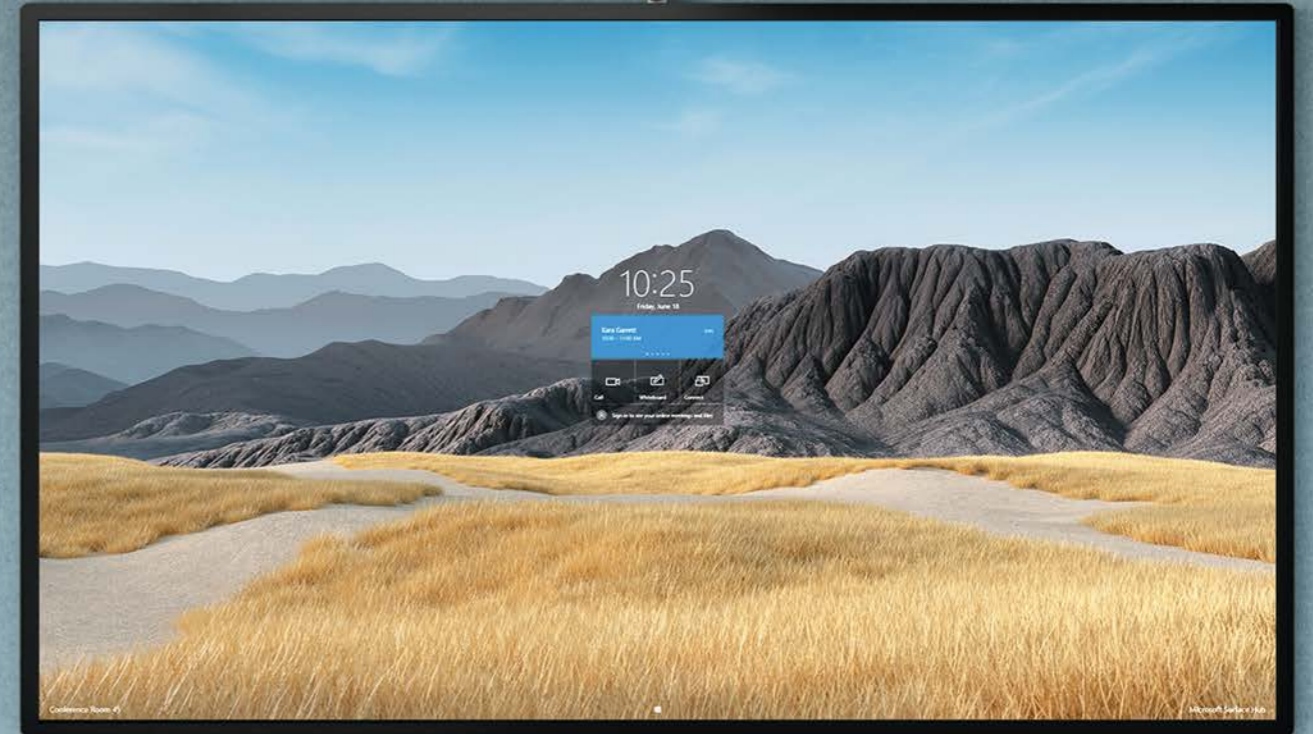

20-0143514



20-0143507

**STATEMENT OF LINE**



19-0118496

50" Mobile Stand



20-0143111

85" Mobile Stand

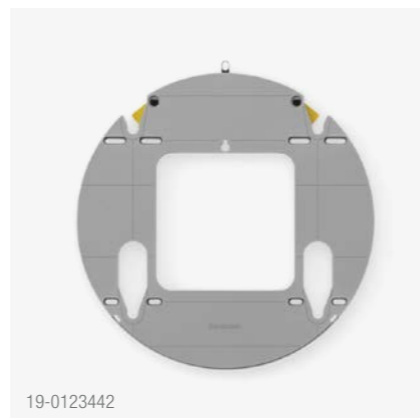

19-0123442

50" Wall Mount



20-0143117

85" Wall Mount



20-0143119

85" Floor Supported Wall Mount

**TECHNICAL SPECIFICATIONS**

	Mobile Stand	Wall Mount	Floor Supported Wall Mount
Dimensions:			
50" Surface Hub 2S:	772 x 1661 x 673 mm	563 mm (overall diameter)	
85" Surface Hub 2S:	1912 x 160 x 739 mm	764 x 1308 x 35 mm	1912 x 1960 x 83 mm
Weight: (without device)			
50" Surface Hub 2S:	28,12 kg	3,18 kg	
85" Surface Hub 2S:	76,83 kg	11,15 kg	38,41 kg
Color:	Arctic White and Microsoft Grey	Arctic White and Microsoft Grey	Arctic White and Microsoft Grey
Features:	<ul style="list-style-type: none"> <li>Storage tray is included to house cords and other essential items when stand is being transported.</li> <li>Tray lid is a water-resistant material designed to protect against spills and stains (tray and battery available on 50" only).</li> <li>Proprietary locking system allows the device to be easily installed and locked in place.</li> <li>360° rotating casters. Two front locking (Surface Hub 2S) or four locking (Surface Hub 2S 85") casters add to stability and safety.</li> <li>Legs are thoughtfully designed to be the ideal circumference for hands to easily grip.</li> <li>Minimal design is easy to clean.</li> </ul>	<ul style="list-style-type: none"> <li>Device is easy to mount.</li> <li>Seismic locking system allows the device to be easily placed, and automatically locks in place.</li> <li>Single wall mount keeps the Microsoft device close to the wall and installs in minutes.</li> <li>Hinged, magnetized panel allows for easy and hands-free access to device components (tray and battery only available on 50").</li> <li>Receiver blocks on wall mount slide vertically to allow for fine-tune leveling.</li> <li>Designed for easy installation on a variety of surfaces.</li> <li>Minimal design is easy to clean.</li> </ul>	<ul style="list-style-type: none"> <li>Leveling glides on the legs for easy adjustments on all flooring types.</li> <li>Mounting brackets allow legs to rest a little farther from the wall.</li> <li>Legs support the weight of the device, so no wall reinforcement is needed.</li> <li>Minimal design is easy to clean.</li> </ul>