

A close-up, low-angle shot of a modern desk's corner joint. The desk is composed of dark grey metal frames and copper-colored rods. The rods are inserted into the frames, creating a sleek, industrial look. The background is a light-colored wooden surface, likely the desk top, which is slightly out of focus. The lighting is soft and directional, highlighting the textures and colors of the materials.

Diversal

Steelcase

Cultivating Diversity.

Rise of Asia innovation

Asia-Pacific is experiencing rapid growth and transformation like never before. Previously known for production, manufacturing and tech support, the region is increasingly leading global innovation. As the landscape continues to evolve, organizations are looking to stay ahead of the field.



“In an extremely short space of time, we are seeing the transition from task-based work to innovative and generative work. Many workplaces have struggled to evolve and adapt to support the organizational cultural change.”

Elise Valoe

Global Research Manager
Steelcase Inc.

“With teams working in dramatically different ways, we sought to design a system to support a new set of behaviors – rapid learning, swift decision making, increased collaboration – integral to innovation.”

Joe Ho

Senior Industrial Designer
Steelcase Asia Pacific



Meet Diversal

Diversal was designed with a simple objective: to address the need for flexibility, both in how companies operate, and how people work and collaborate.

Its dynamic components create a work environment that encourages free-flow information exchange and enhanced collaboration. It can be easily reconfigured to accommodate a diverse range of needs, supporting short and long term layout planning.



01 Dynamic, Collaborative Team Spaces

In this application, Diversal is configured for a neighbourhood, inhabited by a team, who work together to meet shared objectives.

Proximity to co-workers, promotes dynamic interaction and a fluid exchange of information, encouraging collaboration and team efficiency. Display shelves, whiteboards, additional counter space and tackable screens encourage physical thinking, allowing the sharing of work and ideas to be more natural and open.

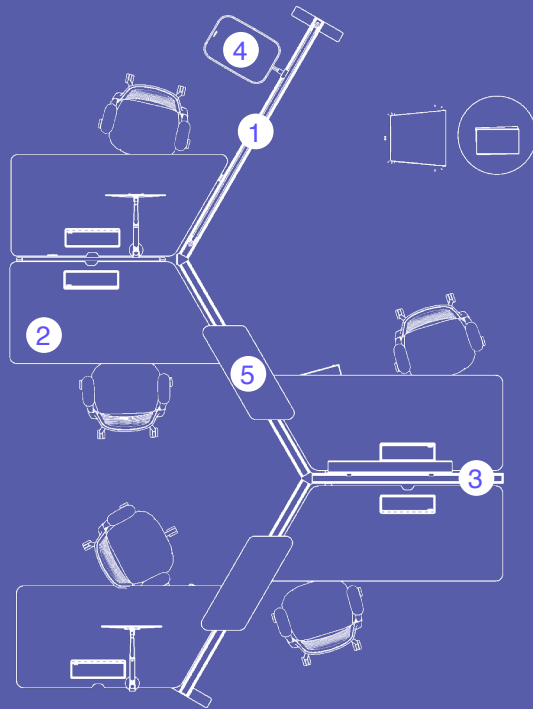

Features:

- 1. Zig zag configuration** encourages spontaneous collaboration within close proximity at workstations to accelerate decision making and increase productivity.
- 2. Blade-shaped work surface** to efficiently provide additional work space.
- 3. Soto rail** supports screens, interactive counters and other optional accessories for personalization.
- 4. Podium** can be added along to support collaboration and allow for changes of posture.
- 5. Interactive shelf** can be added between two colleagues to support paired collaboration, and used as a display shelf.







02 Balancing Focus and Mobility

Designed to meet the needs of nomadic workers, this configuration provides a balance between individual focused work and quick interactions with colleagues. Additional accessories to the collaborative top and nearby social settings, let colleagues easily connect while on-site in the workplace.

Diversal brings power and data to the setting, offering seamless and immediate access for their mobile devices and other technology.

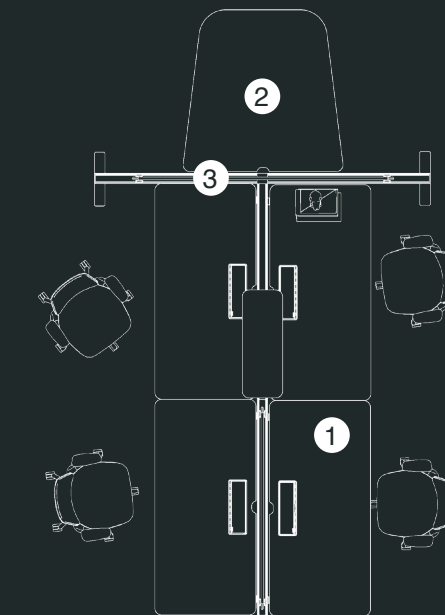

Features:

1. **Fixed work surfaces** can be tethered to Diversal and reconfigured easily or substituted with freestanding, height adjustable desks.

2. **Collaborative top** at the end of the unit supports casual catch-ups and alignments between colleagues.

3. **Screens** are available in 300mm and 500mm height to support varying levels of privacy.





Equipping Specialist Residents

Specialist residents such as programmers, designers or financial analysts, may spend significant periods of time on focused work, using customized work tools such as fixed dual monitors or larger work surfaces, and have a greater need for privacy.

Pairing Diversal with height adjustable solutions can encourage movement and promote wellbeing. A nearby collaborative setting provides space for team huddles.

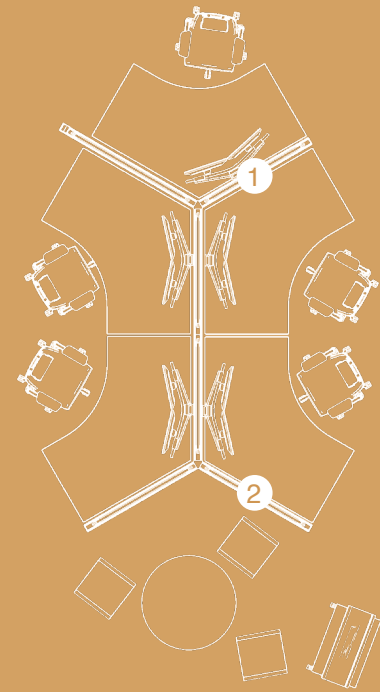

Features:

1. Diversal serves as the power source for free-standing height adjustable desks, allowing flexible and dynamic configurations. Data and power cables can be segregated in upper and lower compartments.

2. Convenient access points provide power when needed, both in and around the setting.





Product Feature Summary



Dynamic Settings
With a system that includes in-line, 90 and 120 degree junctions, Diversal is designed to offer a wide range of settings to accommodate diverse needs and facilitate innovative work culture.



Vibrant Materiality
In addition to the wide range of color choices, Diversal is available in both fabric, for softer finishes, or metal, for a trim modern look and feel, to fit with your team or business.



Customized Privacy
Through a variety of options, including Navi screens and PET light screens, distinct personal spaces can be created in the system to support focused work.



Sleek Design
With a slender beam only 76mm in width, Diversal is discreet, lightweight and designed to maximise any space, providing an intimate yet spacious environment for users to settle in or circulate around.



Sophisticated Power Solution
Diversal's robust power and data system is seamlessly integrated for easy access and maintenance. Dual cable way allows segregation of power and data cables.

Endless Possibilities

Through a simple kit of parts and rich materiality, Diversal empowers companies to customize their space in ways that will facilitate and inspire creativity and innovation.

Paint

- Neutral:
- Arctic White
 - Arctic White Gloss
 - Champagne Metallic
 - Midnight Metallic
 - Sterling Metallic
 - Silver
 - Nickel
 - Black
 - Merle

- Accent:
- Taxi
 - Tangerine
 - Scarlet
 - Blue Jay
 - Wasabi
 - Merlot
 - Aubergine
 - Jungle
 - Lagoon
 - Peacock
 - Honey
 - Saffron

Laminate

- Arctic White
- Seagull
- Maple
- Acacia
- Clear Walnut
- Graphite Walnut
- Merle

PET

- Silver
- Grey
- Dark Grey
- Ivy Green
- Dark Blue
- Raspberry Red
- Sky Blue
- Kiwi Green
- Violet

Fabrvc

- Medley:
- Mustard Yellow
 - Dark Pink
 - Orange Mix
 - Red
 - Cherry Red
 - Sky Blue
 - Water Blue
 - Denim
 - Blue Jean
 - Blue
 - Blue Purple
 - Purple
 - Dark Purple
 - Apple Green
 - Dark Green
 - Khaki Green
 - Beige
 - Chamois
 - Khaki
 - Mocha
 - Light Grey
 - Grey Brown

Cogent Connect:

- Grey
- Pepper
- Pepper Black
- Coconut
- Canary
- Turmeric
- Tangerine
- Saffron
- Scarlet
- Lipstick
- Maya Blue
- Blue Jay
- Lagoon
- Royal Blue
- Blueprint
- Sailor
- Concord
- Aubergine
- Wasabi
- Peacock
- Lizard

Omni-R:

- Malt
- Nugget
- Root Beer
- Quicksilver
- Graphite
- Licorice
- Coconut
- Cloud
- Maize
- Tangerine
- Scarlet
- Crimson
- Blue Jay
- Azure Blue
- Sapphire
- Ink Blue
- Hydrangea
- Wasabi
- Malt
- Cork
- Cocoa

Buzz2:

- Nickel
- Rhino
- Ebonay
- Sunrise
- Pumpkin
- Rouge
- Burgundy
- Blue
- Navy
- Meadow
- Sable
- Stone
- Chocolate
- Alpine
- Tornado
- Black

Surface material images are provided as a preliminary color reference and should not be used for final color selection.

Beam Tile

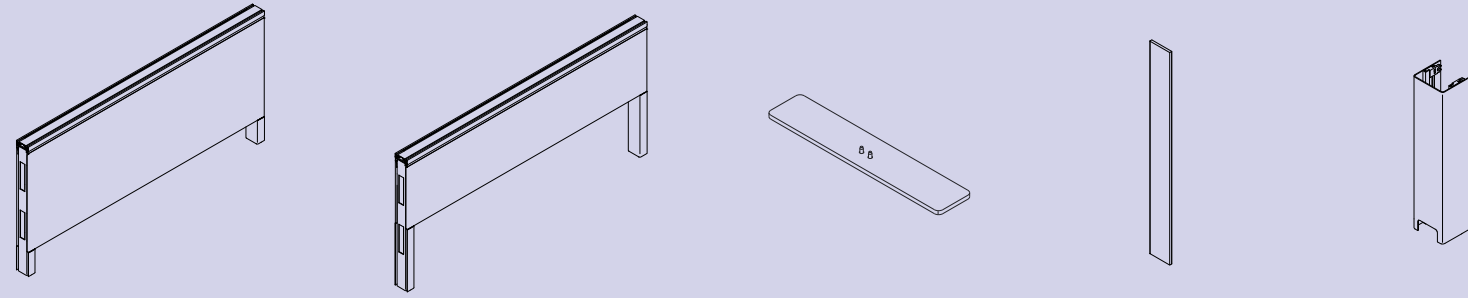

Full height tile
Skin Material: Fabric/ Metal
Half height tile
Stabilizer
End-of-run Cover
Cable Cover

Junctions



T Junction
L Junction
Y Junction
V Junction
X Junction
Utility Pole

Work Surface

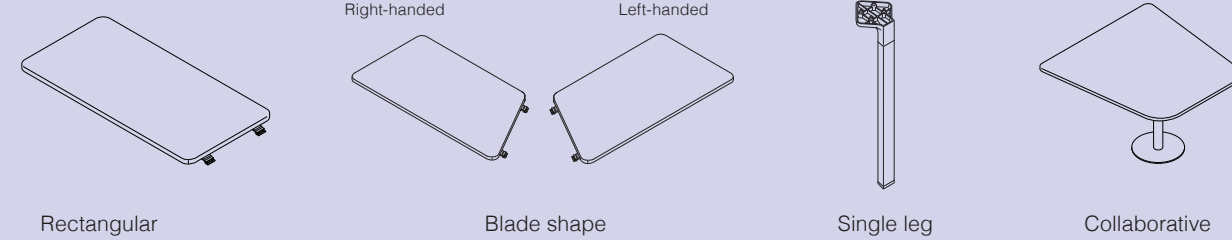

Rectangular
Blade shape
Single leg
Collaborative

SOTO Accessories

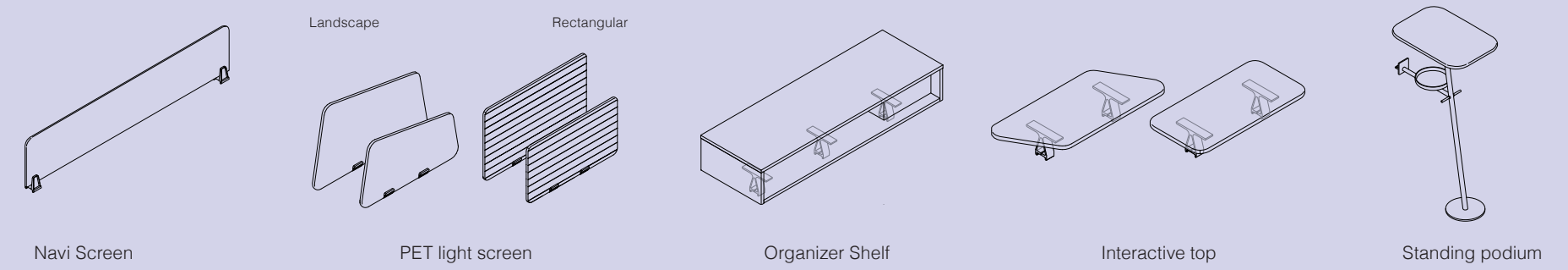

Navi Screen
PET light screen
Organizer Shelf
Interactive top
Standing podium

Worksurface Accessories

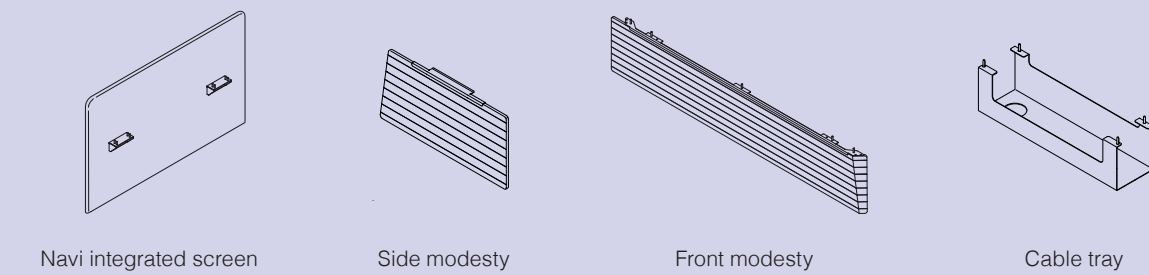

Navi integrated screen
Side modesty
Front modesty
Cable tray

The Greener Choice



Diversal is designed to be future proof. Its flexibility allows it be reconfigured to suit the evolving needs of any organisation, minimising waste and reducing cost. Sustainability is at the heart of Diversal's design, providing long lasting value to its users and minimally impacting the environment. Its social and environmental performance is communicated through the following voluntary labels and certifications:

- SCS Indoor Advantage™
- China Environmental Label
- Chinese National Standards (GB Standards)
- Green Tick

Diversal
Cultivating Diversity.

Steelcase

steelcase.asia

Hong Kong +852 2520 0160

Sydney +61 2 9660 5511

Beijing +86 10 5911 3988

Mumbai +91 22 6121 3500

Delhi +91 124 6103 000

Tokyo +81 3 3448 9611

Shanghai +86 21 6137 6288

Singapore +65 6738 5225

Bangalore +91 80 3055 0300

Hyderabad +91 40 6704 6400

©2018 Steelcase Inc. All rights reserved. All specifications subject to change without notice.
Trademarks used herein are the property of Steelcase Inc. or of their respective owners.