

Steelcase

Migration SE Pro
User Guide

Important Safety Instructions

When using an electrical furnishing, basic precautions should always be followed, including the following:

Read all instructions before using this furnishing.



DANGER

To reduce the risk of electric shock:

1. Always unplug this furnishing from the electrical outlet before cleaning or servicing.



WARNING

To reduce the risk of burns, fire, electric shock, or injury to persons:

1. Unplug from outlet before putting on or taking off parts.
2. Close supervision is necessary when this furnishing is used by, or near children, invalids, or disabled persons.
3. Use this furnishing only for its intended use as described in these instructions. Do not use attachments not recommended by the manufacturer.
4. Never operate this furnishing if it has a damaged cord or plug, if it is not working properly, if it has been dropped or damaged, or dropped into water. Return the furnishing to a service center for examination and repair.
5. Keep the cord away from heated surfaces.
6. Never operate the furnishing with the air openings blocked. Keep the air openings free of lint, hair, and the like.
7. Never drop or insert any object into any opening.
8. Do not use outdoors.
9. Do not operate where aerosol (spray) products are being used or where oxygen is being administered.
10. To disconnect, turn all controls to the off position, then remove plug from outlet.
11. **WARNING:** Risk of Injury – Keep children away from extended columns.
12. **WARNING:** Risk of Electric Shock – Connect this furnishing to a properly grounded outlet only. See Grounding Instructions.
13. **WARNING:** Risk of Electric Shock, Fire and Injury – Review the assembly instructions to confirm that the appropriate critical components and accessories are being used with the furnishing.
14. For loading always put heavier items at the bottom and not near the top in order to help prevent the possibility of the furnishing tipping over.
15. **WARNING:** Risk of Injury – maximum load 227 pounds (103kg) (including worksurface).
16. **WARNING:** Risk of Injury to persons – do not use this furnishing to support televisions.

17. This powered, height-adjustable desk appliance is not intended for use by persons (including children) with reduced physical, sensory or mental capabilities, or lack of experience and knowledge, unless they have been given supervision or instruction concerning use of the appliance by a person responsible for their safety.
18. Children should be supervised to ensure that they do not play with the appliance.
19. When the height-adjustable appliance is provided with two power supply cords, both cords should be unplugged before movement, testing, or repair of the product.
20. This appliance is intended for household or commercial use.
21. The unit has no user serviceable parts.
22. The product is rated 120 V ~ 60 Hz, 400 W.

SAVE THESE INSTRUCTIONS

Grounding Instruction

This product is for use on a nominal 120-volt circuit, and has a grounding plug that looks like the plug illustrated in sketch A in following figure. Make sure that the product is connected to an outlet having the same configuration as the plug. No adapter should be used with this product.

Grounding Methods

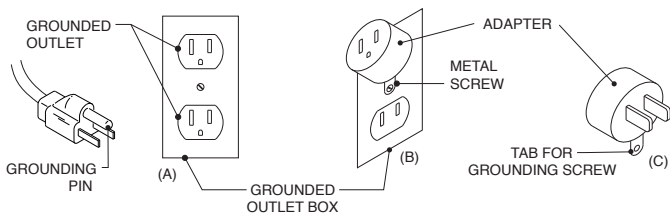



WARNING

Pinch Points, Keep Clear



RISKS OF SERIOUS INJURY

If not used as intended, moving worksurfaces can pinch and cause injury or property damage. Always follow these instructions:

1. Keep height-adjustment range free from obstructions above and below the worksurface.
2. Plan for a minimum 25mm gap against a wall or panel.
3. Plan for a minimum 25mm gap to adjacent furniture.

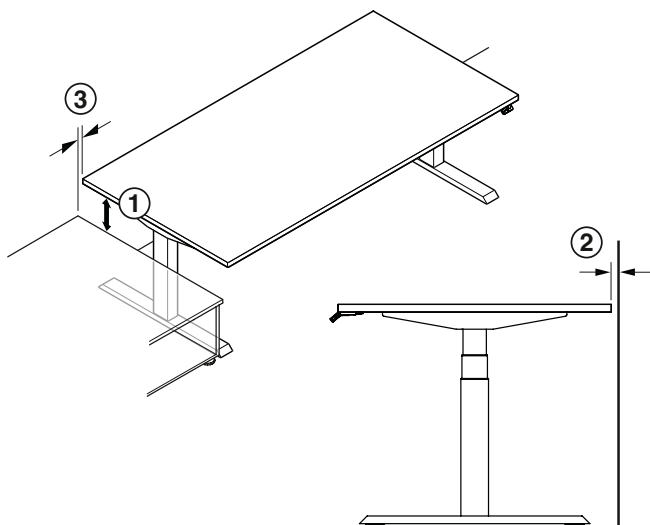

- This powered, height-adjustable desk appliance is not intended for use by persons (including children) with reduced physical, sensory or mental capabilities, or lack of experience and knowledge, unless they have been given supervision or instruction concerning use of the appliance by a person responsible for their safety.
- Children should be supervised to ensure that they do not play with the appliance.
- Place the furniture at a location where it avoids creating entrapment hazards with other furniture.
- Regularly clean dust and dirt from lifting columns. A damp cloth is recommended.
- To protect the painted surfaces, use a cleaner that is not highly alkaline or acidic. A pH-neutral supply product is ideal.
- Disconnect the supply when carrying out maintenance and cleaning.
- Examine the appliance frequently for signs of wear or damage. If there are such signs or if the appliance has been misused or does not work, contact the supplier for further information.
- Do not allow children to play with fixed controls.
- When operating a switch that initiates and maintains the movement of the furniture or terminates the movement of the furniture or causes a change of the direction of the movement of the furniture, make sure that other persons are kept away.

Manual Guide

Standard Handset - Up/Down Controls



Height Ranges

2-Stage : 720mm - 1180mm
3-Stage : 650mm - 1250mm

- A. Up Button
- B. Down Button

Upgraded Handset - 4 Memory Preset

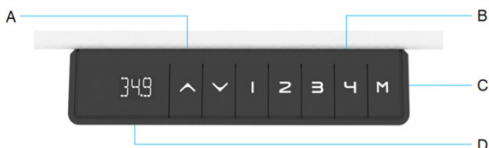

- A. Height Adjustment Buttons
- B. Memory Position Buttons
- C. Memory Setting Buttons
- D. Digital Display

PROGRAMMING MEMORY PRESETS

1. Press the up or down arrow to set the worksurface to the desired height.
2. Press "M" button followed by one of the preset number buttons (1,2 or 3) on the LED screen.
3. The table will automatically reset to this height whenever the preset number is pressed and held* until the preset height is reached.

POWER SAVING MODE – WAKING UP THE HANDSET

1. Press any button to wake up handset.

RESETTING THE BASE

Note: Make sure there is nothing under the base before setting to its lowest position. If the cable is obstructed it will not reset properly.

1. Press and hold the Down arrow; the desk will begin to go down.
2. Once the desk reaches its lowest height, continue to press the Down arrow for 5 seconds, until the digital display shows "RST".
3. Release and then press the Down arrow again; the recalibration process will now begin.
4. When reset is complete, the digital display will show **650mm (3-stage)** or **720mm (2-stage)**.

Troubleshooting Guide

Most issues will resolve by re-setting the base. See reset instructions on previous page.

Note: Make sure there is nothing under the base before setting to its lowest level. If the cable is obstructed it will not reset properly.

Please ensure that all connections are tight and intact before further troubleshooting.

| ISSUE | SOLUTION |
|--|--|
| ASR/RST Error Code | Reset the base. |
| No power/LED on control box is off | The control box may be damaged-contact us for replacement. |
| E07/E08 Error Code (legs not moving uniformly) | <ol style="list-style-type: none">1. Reset the base.2. If the issue persists, swap the connecting cables.3. If the issue persists, contact us for a replacement. |
| H01 Error Code (Controller Overheat) | Disconnect the power for 1 minute and then reconnect the handset. |
| Handset Display Error (eg: "88.8") | The handset may be damaged-contact us for replacement. |

For questions and support, please contact Steelcase Customer Care.

Please ensure that all connections are tight and intact before further troubleshooting.

| ISSUE | SOLUTION |
|---|--|
| Base is not moving or operates irregularly. | <ol style="list-style-type: none">1. Make sure that all connections are intact and that the outlet has power.2. Once connection are verified, reset the base.3. If the issue persists, please contact our Customer Care. |
| Base stops and can only move downwards. | <ol style="list-style-type: none">1. Base might be overloaded.2. Remove some of the weight on the worksurfaces and try again.3. If the issue persists, please contact customer service. |
| Movement only in one leg. | <ol style="list-style-type: none">1. Make sure that all connections are intact and the outlet has power.2. Once connections are verified, reset the base.3. If the issue persists, please contact customer service. |

Steelcase[®]

Visit [steelcase.com](https://www.steelcase.com)

Part Number 1452983001 Rev. A

All rights reserved. All specifications subject to change without notice.