

Installation Instructions

156796 Rev C

SlatRail
WSRW
WSRU1
WSRFS

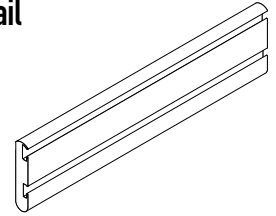

Each piece of SlatRail has two usable "slats".
The upper slat should be used in all applications.
The lower slat is only intended to be used in cases where 2 slats are necessary.

Each piece of SlatRail is rated to a 100 lbs. load.

Local codes and interpretations vary.

Review installation with local authorities to ensure compliance with applicable codes.

Panel Mount

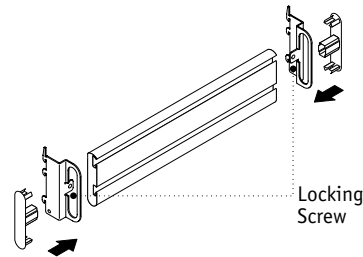

Make an assembly.

Panel mount brackets are intended for use on any panel system that uses 1" vertical slots.

Angle top tooth of bracket into panel.
Shift bracket down in the panel slots to lock.

Install Rail and End Caps.

Tighten plastic locking screws.

SlatRail may overhang panel mount brackets by up to 12".

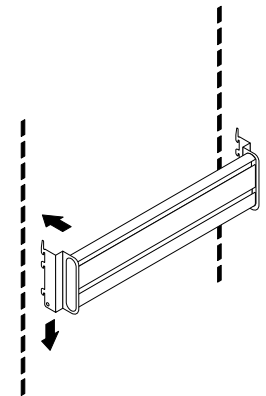

Wall Mount

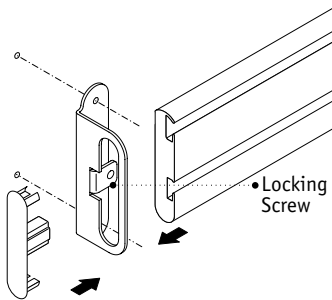

- Locate wall studs and mark screw locations.
- Pre-drill holes 1" into the wall with 9/64" drill bit.
- Turn screws until bracket is flush against wall. Do not torque excessively. Install Rail and End Caps.
- Tighten plastic locking screws.

- For wood studs, use four (4) #10 wood screw fasteners (not included).
- For steel studs, use four (4) #10 wall anchors (not included).
- For drywall, use four (4) #10 wall anchors (not included).

Note: Studs must fall within 12" of end SlatRail.

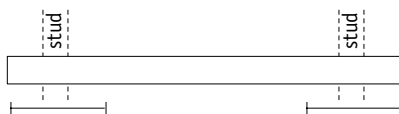

Stanchion Mount

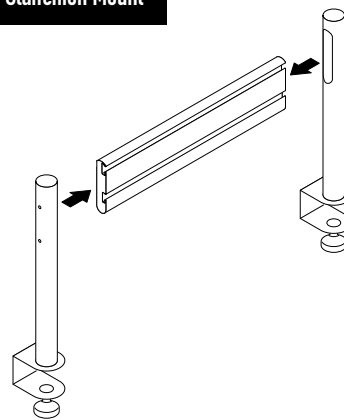

Fit SlatRail in between the mounting stanchions.

Insert and tighten the retention screws to make an assembly.

NOTE: Stanchions are intended for use on straight surfaces only.

Securely tighten stanchions to the worksurface edge using the knob provided.

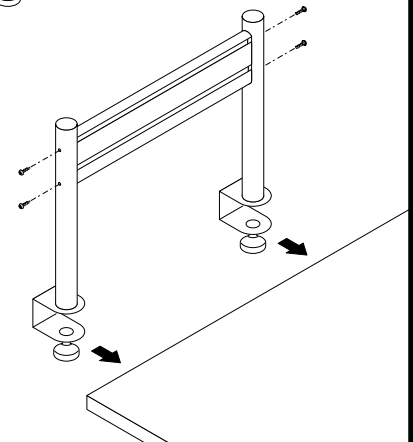

For a better day at work.™

details®

A STEELCASE COMPANY

www.details-worktools.com
Details Customer Alliance 800.833.0411
All rights reserved. Printed in U.S.A. 9/05