

# sonata

MODULAR CASEGOODS



## OBSERVATION:

MANY HEALTHCARE ENVIRONMENTS ARE DUE FOR A CHECK UP.



An oncology environment should thoughtfully consider the important roles of the patient, care provider, and partner in care. In many current cancer clinics, the individual needs of these three are not being met. Patients are separated from the care partners. Clinical supplies compete with personal items at the patient's side. Privacy and personal space are not included in the layout. By understanding the environment, the experience for all three can improve.

## RESEARCH:

**THE PROCESS** To create environments that improve the cancer care experience, Nurture embarked on an extensive journey of research and design. We sought to understand cancer—what it is and the types of treatment available. Then we observed individuals in cancer care environments. We saw caregivers struggling to provide patient privacy in open treatment areas, and conversely, trying to oversee more than one patient at a time in isolated private rooms. In these environments, partners in care were an afterthought. Nurture synthesized these observations creating insights to guide the product development process.

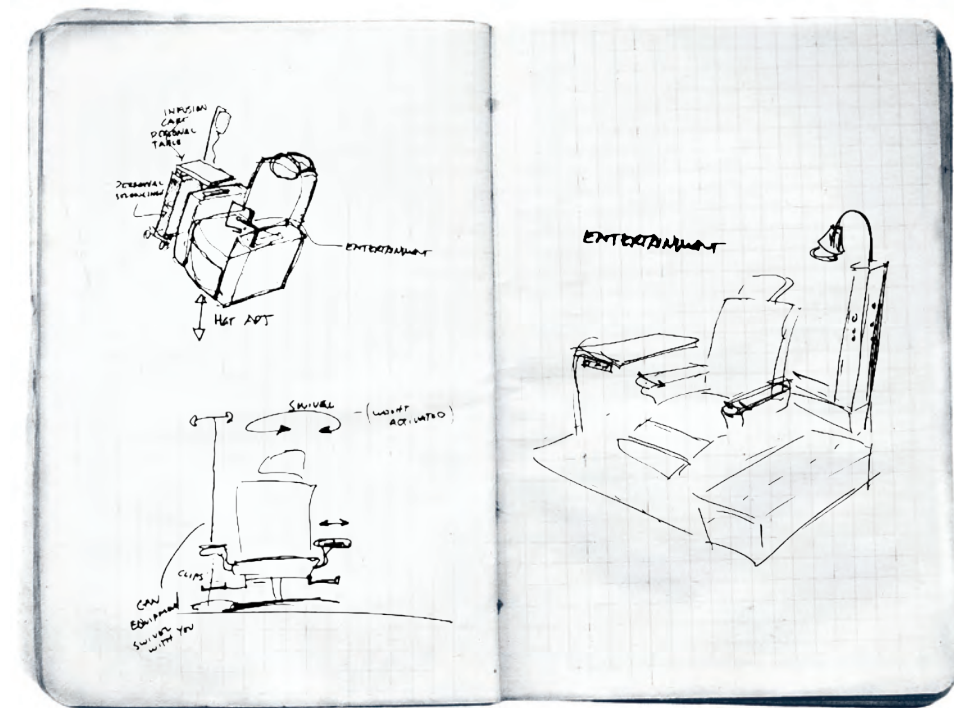

## INSIGHTS:

**TRANSITIONS** The cancer experience is different for every patient. *Does the space respond to varying needs for privacy, companionship, education and treatment?*

**FAMILY TIES** Care partners are integral to the healing process because they provide vital support to the patient. *Has the family been planned for in the treatment area with a space for them to relax, talk, or connect to the outside world?*

**SPATIAL RELATIONS** When healthcare spaces are designed based solely on architectural programming, important relationships among staff, patients and families can be overlooked. *Has space and adjacencies been planned around the interpersonal interactions necessary to cancer care?*

**FACING THE FEAR** The prospect of being diagnosed and treated for cancer provokes anxiety, however staff may be desensitized to the intimidating and unsettling nature of clinical equipment. *Does the space consider ways to offset the unpleasant aspects of care delivery?*

**DETAILS, DETAILS** Cancer treatment is an arduous experience which can be made worse by annoyances such as inaccessible power outlets, a lack of personal storage, and inconveniently located medical supplies and waste receptacles. *Where are the simple conveniences to ease the strain on patients and staff?*



### THE THREE Cs

Connection, Comfort, and Convenience – Sonata accommodates them all through mindful, modular solutions. Product choices can be tailored to the needs of each individual environment and because change happens, Sonata can be easily reconfigured or added to over time.



## CONNECTION

With Sonata, connection means support for conversation, companionship, and treatment. The relationships between individuals in these spaces play important roles in the healing process. Supportive settings offer control and customization for a range of needs – with space for the care partner, sight lines for the care provider, and privacy without isolation for the patient. When people come together in meaningful ways, care is at its best.



*A modular solution creates a semi-enclosed landscape providing privacy without isolation for the patient and their guest.*



## COMFORT

Sonata emphasizes comfort as a priority, both physical and emotional. Warm and welcoming, it creates home-like spaces for the patients and their families. Open personal storage provides a spot for big and small items, keeping them in sight. Places to plug in and a spot for a personal TV bring technology to the space, for entertainment or work. Sonata understands that for patients, caregivers and partners in care, it's the small things that makes a big difference.

*A bench provides seating and storage, a wardrobe stows belongs in sight, and a media unit supports entertainment.*





## SOLUTIONS-BASED PLANNING: WHAT YOU'VE SEEN

With Sonata's modular design, any combination of the modules is possible allowing a solution to be tailored to a clinic's specific needs. For a comprehensive portfolio of planning ideas to inspire your next project explore Design Tools at nurture.com.

### PAGES 4-5

1. Entertainment support at each bay
2. Wastebin storage behind a sliding door, hiding the waste while keeping it easily accessible from both sides
3. A hinged top bench which provides an additional seat at patient side and also a place to store blankets and pillows
4. Drawers to store medical supplies easily within reach at the patient side
5. Pull out surface to provide a spot for material prep
6. A spot for coats and personal belongings in sight



### PAGE 6

1. Wastebin storage, keeping the ugly hidden but easily accessible through hands-free disposal
2. Supplemental surface for material prep on dual-sided unit
3. Entertainment support and personal storage for the patient and their guest
4. 39" high worksurface, perfect for standing work with sight-lines to multiple patients
5. Power routed through a shared base and brought up to where it's needed
6. Room for the care partner at patient side



### PAGE 7

1. Drawers to store medical supplies at patient side
2. A spot for the patient's guests as well as their things
3. Entertainment for the patient and their guest
4. Pull out surface for material prep, there when it's needed, pushed away when it's not
5. Wastebin storage on a slide-out, hidden behind a sliding door
6. Individual bays provide privacy without isolation



### PAGE 8

1. Bench provides a place to sit and open storage keeping personal belongings in sight
2. Power accommodation in the Nurse Server brings power where it's needed
3. An upper shelf provides a spot for a cup or magazine and place to plug in a personal media device
4. Front access wastebin storage with a toe pull for easy hands free removal
5. Base seals to floor making it easy to clean around
6. 39" high worksurface for standing work with sight-lines to multiple patients



## CONVENIENCE

Sonata makes a lot of sense in clinical environments, creating thoughtful conveniences for work process.

Drawers provide medical supply storage at the patient side and a pullout surface supplies a spot for material prep.

Wastebin storage is easily accessible but hidden from sight and worksurfaces are designed at appropriate heights for standing work. With Sonata, everything is in its place, right where it's needed.



*An island module stores the wastebin behind a sliding door and a nurse server has drawers and a pullout surface, making work easier.*

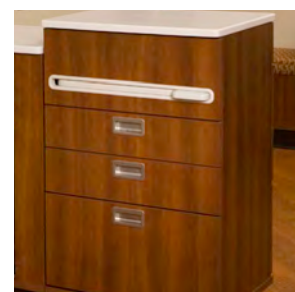

**NURSE SERVER**

Medical supply storage, hands-free waste removal, accommodation of power, and 39" height for standing work. Available as single or double sided in two models, one with three drawers and one with front access wastebin storage.

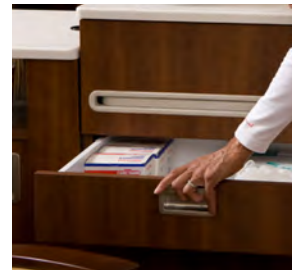

*Drawer storage provides a place for medical supplies*



*Pull-out surfaces for material prep*



*Wastebin storage features toe pull and accommodates up to a 17-gallon bin when specified without the pullouts*



*Power accommodation optional on top surface of the nurse server with wastebin storage*

**MEDIA UNIT**

Entertainment support and storage for the patient and their guest. Available as single or double sided.



*Designed for wiring with a power chase down the center of the unit*



*Includes a place to mount a flat screen within the cabinet and a shelf below for media player*

**BENCH**

A combination storage and seating solution at the patient's side. Available as single or double sided in hinged top or open storage versions.

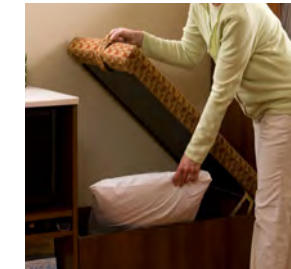

*Closed storage with a hinged top to store blankets and pillows*



*Open storage available with a cushion top or solid surface top*

**ISLAND**

Hands-free access to waste removal, accommodation of power, and personal storage. Available as single or double sided in two models: 36" wide with open storage or 48" wide with open storage and wastebin storage with a sliding door.



*48" wide island features wastebin slide-out, accessible from both sides and hidden by sliding door*



*Two power chases to bring power where it's needed*

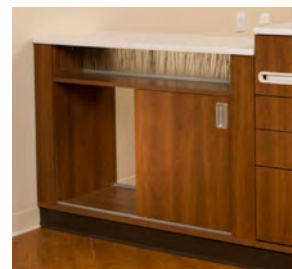

*Open lower storage compartment for larger personal belongings*



*Upper shelf with an outlet for patient's technology and personal belongings*

**WARDROBE**

Open storage for patient and care partner's personal belongings. Available as single or double sided.

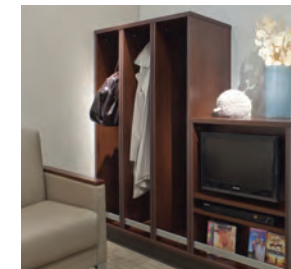

*60" high to store coats and bags*



*Unit includes coat hook*

**BASE**

A common base is shared by all modules, it is available in a variety of widths to accommodate any product combination. The base acts as a utility chase for the modules on it and seals the application to the floor by accommodating cove molding.

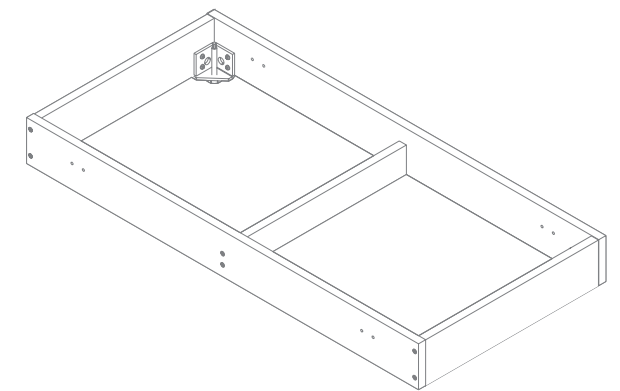

## LAMINATE

SUGAR LOAF  
MAPLE



ALMOND  
CHERRY



SAMBA  
CHERRY



COGNAC  
CHERRY

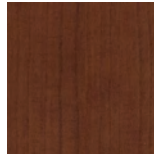

DARK RUM  
CHERRY

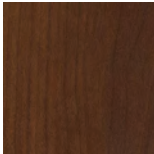

SHIRAZ  
CHERRY

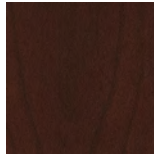

FLAMENCO  
CHERRY

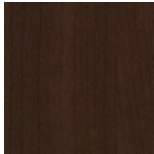

Laminate top surfaces also available in Steelcase laminate finishes.  
For a comprehensive list of all available finishes visit:  
Nurture.com > Design Tools > Hard Surface Materials

## SOLID SURFACE

ANTARCTICA



BISQUE

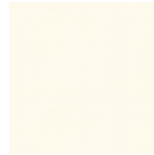

LINEN

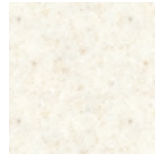

CANVAS

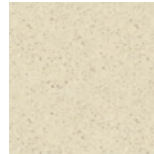

## RTF

SAND



RTF available on top surfaces and Nurse Server pull-out surfaces.  
A complete collection of Solid Surface finishes is available.  
Refer to the Nurture specification guide for listing.

## STATEMENT OF LINE



NURSE SERVER - DRAWERS  
OVERALL:  
18"D x 24"W x 39"H



NURSE SERVER - WASTEBIN  
OVERALL:  
18"D x 24"W x 39"H

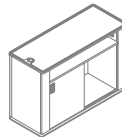

ISLAND - SLIDING DOOR  
OVERALL:  
18"D x 48"W x 36"H

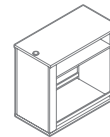

ISLAND - OPEN  
OVERALL:  
18"D x 36"W x 36"H



MEDIA UNIT  
OVERALL:  
18"D x 24"W x 36"H

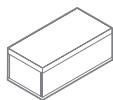

BENCH - HINGE TOP  
OVERALL:  
18"D x 36"W x 19"H

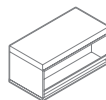

BENCH - OPEN  
OVERALL:  
18"D x 36"W x 19"H



WARDROBE  
OVERALL:  
18"D x 12"W x 60"H



BASE  
OVERALL:  
18"D x 12-84"W x 4"H



ACCESSORIES  
COAT HOOK  
FLAT SCREEN MONITOR ARM